

DEMOLITION MAN™

OPERATIONS MANUAL

Operations & Adjustments ◦ Testing & Problem Diagnosis
Parts Information ◦ Wiring Diagrams & Schematics

Williams Electronics Games, Inc.
3401 N. California
Chicago, IL 60618

ROM Jumper Chart

	W1	W2
1M / 2M / 4M ROM	In	Out

Country DIP Switch Chart

	Sw4	Sw5	Sw6	Sw7	Sw8
American	On	On	On	On	On
European	On	On	Off	On	On
French	On	On	On	Off	Off
German	On	On	On	On	Off
Spanish	On	Off	On	On	On

SOLENOID / FLASHER TABLE

Sol. No.	Function	Solenoid Type	Voltage Connections			Driver	Drive Connections			Drive Wire Color	Solenoid Part Number Flashlamp Type	
			Playfield	Backbox	Cabinet		Playfield	Backbox	Cabinet		Playfield	Backbox
01	Ball Release	High Power	J107-3			Q82	J130-1			Vio-Brn	AE-26-1500	
02	Bottom Popper	High Power	J107-3			Q80	J130-2			Vio-Red	AE-23-800	
03	Auto Plunger	High Power	J107-3			Q78	J130-4			Vio-Org	AE-23-800	
04	Top Popper	High Power	J107-3			Q76	J130-5			Vio-Yel	AE-28-1500	
05	Diverter Power	High Power	J107-3			Q64	J130-8			Vio-Grn	A-15943-1	
06	Not Used	High Power				Q66				Vio-Blu		
07	Knocker	High Power		J107-3		Q68		J130-8		Vio-Blk		AE-23-800
08	Not Used	High Power				Q70				Vio-Gry		
09	Left Slingshot	Low Power	J107-2			Q58	J127-1			Brn-Blk	AE-26-1200	
10	Right Slingshot	Low Power	J107-2			Q56	J127-3			Brn-Red	AE-26-1200	
11	Left Jet Bumper	Low Power	J107-2			Q54	J127-4			Brn-Org	AE-26-1200	
12	Top Slingshot	Low Power	J107-2			Q52	J127-5			Brn-Yel	AE-26-1200	
13	Right Jet Bumper	Low Power	J107-2			Q50	J127-6			Brn-Grn	AE-26-1200	
14	Eject	Low Power	J107-2			Q48	J127-7			Brn-Blu	AE-26-1200	
15	Diverter Hold	Low Power	J107-2			Q46	J127-8			Brn-Vio	A-15943-1	
16	Not Used	Low Power				Q44				Brn-Gry		
17	Claw Flasher	Low Power	J107-6	J106-5		Q42	J126-1	J125-1		Blk-Brn	#906 (1)	#906 (1)
18	Elevator Motor		J118-2			Q40	J126-2			Blk-Red	14-7993	
19	Claw Motor Left		J118-2			Q38	J126-3			Blk-Org	14-7992	
20	Claw Motor Right		J118-2			Q36	J126-4			Blk-Yel	14-7992	
21	Jeis Flasher	Flasher	J107-6	J106-5		Q28	J126-5	J125-6		Blu-Grn	#89 (1)	#906 (1)
22	Side Ramp Flasher	Flasher	J107-6	J106-5		Q30	J126-6	J125-7		Blu-Blk	#89 (1)	#906 (1)
23	Left Ramp Up Flshr	Flasher	J107-6	J106-5		Q34	J126-7	J125-8		Blu-Vio	#906 (1)	#906 (1)
24	Left Ramp Lwr Flshr	Flasher	J107-6	J106-5		Q32	J126-8	J125-9		Blu-Gry	#89 (1)	#906 (1)
25	Car Chase Cntr Flshr	Gen. Purpose	J107-6	J106-5		Q26	J122-1	J124-1		Blu-Brn	#89 (1)	#906 (1)
26	Car Chase Lwr Flshr	Gen. Purpose	J107-6	J106-5		Q24	J122-2	J124-2		Blu-Red	#89 (1)	#906 (1)
27	Right Ramp Flasher	Gen. Purpose	J107-6	J106-5		Q22	J122-3	J124-3		Blu-Org	#89 (1)	#906 (1)
28	Eject Flasher	Gen. Purpose	J107-6	J106-5		Q20	J122-4	J124-5		Blu-Yel	#89 (1)	#906 (1)
29-36	<i>See Flipper Circuits</i>											
37*	Car Chase Up Flshr	Low Power	J107-6			Q16	J4-2			Brn-Wht	#89 (1)	
38*	Lower Rebound Flshr	Low Power	J107-6			Q15	J4-4			Blk-Wht	#89 (1)	
39*	Eyeball Flasher	Low Power	J107-6			Q14	J4-5			Org-Wht	#89 (1)	
40*	Center Ramp Flasher	Low Power	J107-6			Q13	J4-6			Yel-Wht	#89 (1)	
41*	Elevator 2 Flasher	Low Power	J107-6			Q9	J3-2			Grn-Wht	#906 (2)	
42*	Elevator 1 Flasher	Low Power	J107-6			Q10	J3-3			Blu-Wht	#906 (1)	
43*	Diverter Flasher	Low Power	J107-6			Q11	J3-4			Vio-Wht	#906 (1)	
44*	Rt. Ramp Up Flasher	Low Power	J107-6			Q12	J3-5			Gry-Wht	#906 (1)	

*Note: Controlled from the 8-Driver Board, not the Power Driver Board

General Illumination

Sol. No.	Function	Solenoid Type	Voltage Connections	Drive Transistors	Drive Connections	Drive Wire Colors	Coil Part Number	Coil Colors
01	Back Panel G.I.	G.I.	J121-1	J120-1		Wht-Brn	#44	#555
02	Upper Right G.I.	G.I.	J121-2	J120-2		Wht-Org	#44	#555
03	Upper Left G.I.	G.I.	J121-3	J120-3		Wht-Yel	#44	#555
04	Lower Right G.I.	G.I.	J121-5	J120-5		Wht-Grn	#44	#555
05	Lower Left G.I.	G.I.	J121-6	J120-6	J119-3	Wht-Vio	#44	#555

Flipper Circuits

Sol. No.	Function	Solenoid Type	Voltage Connections	Drive Transistors	Drive Connections	Drive Wire Colors	Coil Part Number	Coil Colors
(29)	Lower Right Flipper	Lwr. Rt. Power	J907-1 (Red-Grn)	Q4	J902-13	Yel-Gm	FL-11629	Blue
(30)		Lwr. Rt. Hold	J907-1 (Red-Grn)	Q11	J902-11	Org-Gm		
(31)	Lower Left Flipper	Lwr. Lt. Power	J907-4 (Red-Blu)	Q3	J902-9	Yel-Blu	FL-11629	Blue
(32)		Lwr. Lt. Hold	J907-4 (Red-Blu)	Q9	J902-7	Org-Blu		
(33)	Claw Magnet	Up Rt. Power	J907-6 (Red-Vio)	Q2	J902-6	Yel-Vio	SZ-33-3000	
(34)	Not Used	Up Rt. Hold	J907-6 (Red-Vio)	Q7	J902-4	Org-Vio		
(35)	Upper Left Flipper	Up Lt. Power	J907-8 (Red-Gry)	Q1	J902-3	Yel-Gry	FL-11630	Red
(36)		Up Lt. Hold	J907-8 (Red-Gry)	Q5	J902-1	Org-Gry		

J1XX-X = Power Driver Board, JX-X = 8-driver Board, J9XX-X = Fliptronic II Board

IMPORTANT NOTICE

PLEASE READ

Pinball games are now equipped with a SAFETY FEATURE to prevent shocks from the solenoid circuit when the coin door is opened. A new interlock switch assembly (part no. A-18249), located at the left of the coin door opening, has been added to the game. This assembly is a bracket containing the existing memory protect switch on the bottom and a new interlock switch on the top. When the coin door is opened, this new interlock switch opens, breaking the connection to the +50V and +20V winding of the transformer secondary.

A special tool called the Service Switch Actuator is provided for the serviceman/technician that repairs the game. This tool is painted yellow and located in a bag stapled inside the cabinet. The Service Switch Actuator slips over the interlock switch and holds it closed while the coin door is opened, allowing the serviceman to test and repair the solenoid circuit.

Hold the top interlock switch in, then slide the short end of the Service Switch Actuator over the top of the interlock switch bracket and the long end over the center of the switch plunger to hold it in.

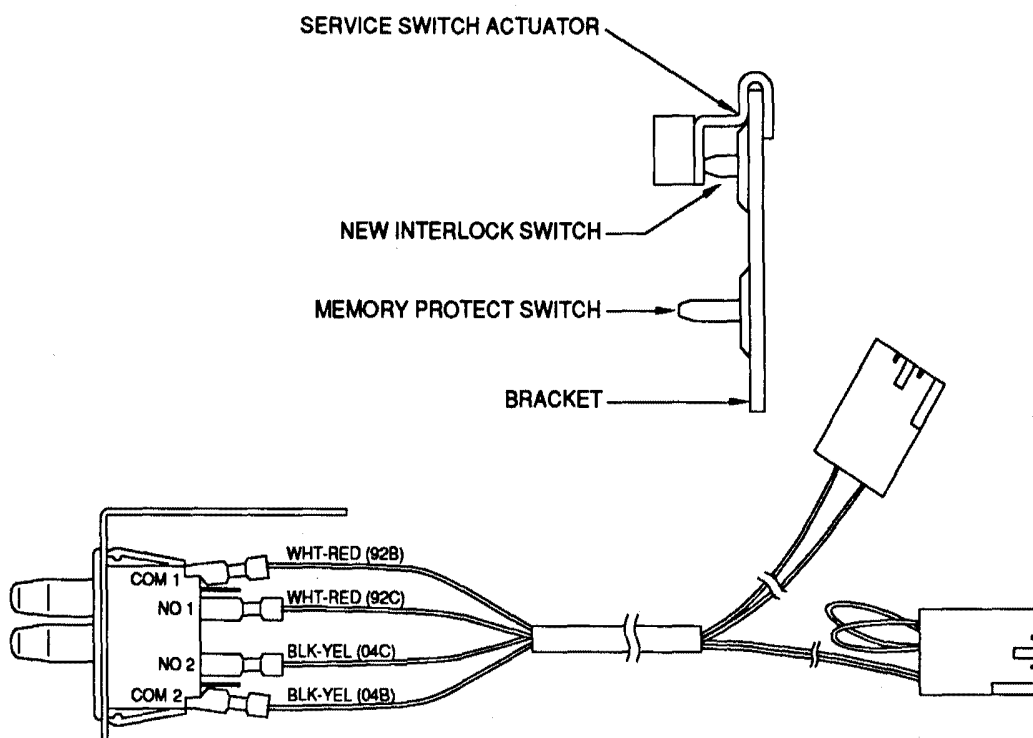

DEMOLITION MAN™

Williams Electronics Games, Inc. reserves the rights to make modifications and improvements to its products. The specifications and parts identified in this manual are subject to change without notice.

RULES

TRIGGERS ON GUN HANDLES OPERATE THE FLIPPERS.

LOAD THE CLAW BY SHOOTING THE RIGHT RAMP WHEN THE DIVERTER IS OPEN.

MOVE THE CLAW WITH THE FLIPPER BUTTONS OR THE GUN TRIGGER.

SELECT THE CLAW GOAL BY DROPPING THE BALL WITH THE LAUNCH BUTTON OR THE
GUN BUTTONS.

"FREEZE" BALLS TO PREPARE FOR MULTIBALL.

START MULTIBALL, WHEN ENABLED, BY SHOOTING LEFT LOOP.

LATER MULTIBALL BATTLES ADD MORE JACKPOT SHOTS FOR BIGGER AWARDS.

MAKE COMBINATION SHOTS TO BUILD COMBO BONUS, LIGHT EXTRA BALL AND ACTIVATE
THE COMPUTER.

COMPLETE MTL ROLLOVERS TO ADVANCE BONUS MULTIPLIER AND LIGHT EXTRA BALL.

Table Of Contents

Section 1 - Game Operation & Test Information

Rules	ii
(System WPC) ROM Summary.....	1-1
Pinball Game Assembly Instructions.....	1-2
Pinball Assembly, Playfield Pitch Angle, & Leg Leveler Detail.....	1-2
Leg Bolt Locations.....	1-2
Line Cord Installation.....	1-4
Raising the Playfield.....	1-5
Game Control Locations.....	1-6
Game Operation.....	1-7
Menu System Operation & Main Menu.....	1-8
Bookkeeping Menu	1-9
B.1 Main Audits.....	1-9
B.2 Earnings Audits.....	1-9
B.3 Standard Audits.....	1-10
B.4 Feature Audits.....	1-11
B.5 Histograms.....	1-12
B.6 Time-Stamps.....	1-12
Printouts Menu.....	1-13
Test Menu.....	1-14
T.1 Switch Edges.....	1-14
T.2 Switch Levels.....	1-14
T.3 Single Switches.....	1-14
T.4 Solenoid Test.....	1-15
T.5 Flasher Test.....	1-15
T.6 General Illumination Test.....	1-15
T.7 Sound & Music Test.....	1-16
T.8 Single Lamp Test.....	1-16
T.9 All Lamp Test.....	1-16
T.10 Lamp & Flasher Test.....	1-16
T.11 Display Test.....	1-16
T.12 Flipper Coil Test.....	1-16
T.13 Ordered Lamps Test.....	1-17
T.14 Claw Test.....	1-17
T.15 Empty Balls Test.....	1-18
Utilities Menu.....	1-19
U.1 Clear Audits.....	1-19
U.2 Clear Coins.....	1-19
U.3 Reset H.S.T.D.	1-19
U.4 Set Time & Date.....	1-19
U.5 Custom Message.....	1-19
U.6 Set Game I.D.	1-19
U.7 Factory Adjustment.....	1-19
U.8 Factory Reset.....	1-19
U.9 Preset.....	1-20
Difficulty Setting Table for U.S., Canadian, French, German & European Games.....	1-20
Preset Adjustments Table for U.S. & Canadian Games.....	1-20
Preset Adjustments Table for German Games.....	1-22
U.10 Clear Credits.....	1-22
U.11 Auto Burn-in.....	1-22
Adjustment Menu.....	1-23
A.1 Standard Adjustments.....	1-23
A.2 Feature Adjustments.....	1-27
A.3 Pricing Adjustments.....	1-31

Section 1 - Game Operation & Test Information Continued...

Pricing Table.....	1-33
A.4 H.S.T.D. Adjustments.....	1-34
A.5 Printer Adjustments.....	1-35
Error Messages.....	1-36
Opto Theory.....	1-37
CPU Board LED Error Codes.....	1-37
Sound Board Beep Error Codes.....	1-37
Cryoclaw/Elevator.....	1-38
LED List.....	1-40
Fuse List.....	1-41
Maintenance Information.....	1-42
Lubrication.....	1-42
Switch Contacts.....	1-42
Cleaning.....	1-42
Playfield Disassembly.....	1-43
Removing the Cryoclaw.....	1-43
Removing the Elevator.....	1-43
Removing the Ramps.....	1-44

Section 2 - Game Parts Information

Backbox Assembly.....	2-2
Cabinet Assembly.....	2-3
Line Filter/Cordset Application Chart.....	2-4
Sound Board Assembly.....	2-5
Fliptronic II Board Assembly.....	2-6
Dot Matrix Controller Assembly.....	2-7
Power Driver Assembly.....	2-8
CPU Board Assembly.....	2-10
LED 7 Ball Trough Assembly, Opto 7 Ball Trough Assembly.....	2-11
Coin Door Interface PC Board, Motor EMI PCB Assembly.....	2-12
Flipper Opto PCB Assembly, DC Motor Control PCB Assembly.....	2-13
7-switch Opto PCB Assembly, Cryoclaw Opto PCB Assembly.....	2-14
Aux Driver (8-driver) PCB Assembly, Elevator Opto PCB Assembly.....	2-15
Flipper Assembly.....	2-16
Kicker (slingshot) Arm Assembly.....	2-18
Outhole Ball Trough Assembly.....	2-19
Jet Bumper Assembly, Jet Bumper Coil Assembly.....	2-20
Ball Eject Assembly.....	2-21
Kicker Bracket Assembly, Knocker Assembly.....	2-22
Tilt Mechanism Assembly.....	2-23
Back Panel Assembly, Elevator Assembly.....	2-24
Cryoclaw Assembly.....	2-26
Control Handle Assemblies.....	2-28
Ball Popper Assembly.....	2-30
Ramp Diverter Assembly.....	2-31
Chute Assembly.....	2-32
Universal Power Interface Assembly.....	2-33
Target Assemblies.....	2-34
Posts.....	2-35
Unique Parts.....	2-36
Cables.....	2-38
Upper Playfield Parts Location.....	2-39
Lower Playfield Parts Location.....	2-40

Section 2 - Game Parts Information Continued...

Rubber Rings.....	2-41
Lamp Matrix.....	2-42
Lamp Location.....	2-43
Switch Matrix.....	2-44
Switch Location.....	2-45
Solenoid Table.....	2-46
Solenoid Location.....	2-47
Ramp Location.....	2-48

Section 3 - Schematics, Wiring Diagrams & Circuit Theory

Connector & Component Identification.....	3-1
Switch Matrix and Circuit.....	3-2
Dedicated Switch Circuit.....	3-3
Lamp Matrix and Circuit.....	3-4
Solenoid Table.....	3-5
Solenoid Wiring.....	3-6
Flashlamp Wiring.....	3-7
High Power and Low Power Solenoid Circuits.....	3-8
Flashlamp and Special (General Purpose) Solenoid Circuits.....	3-9
General Illumination Circuits.....	3-10
Flipper Circuit Diagram.....	3-11
Flipper Coil and E.O.S. Switch Circuit Diagrams.....	3-12
Flipper Cabinet Switch Circuit Diagrams.....	3-13
Flipper Opto PCB Assembly.....	3-14
LED and Photo Transistor PCB Assemblies.....	3-15
7 Ball Trough Photo Transistor PCB Assembly.....	3-16
7 Ball Trough LED PCB Assembly.....	3-17
7-Opto Switch PCB Assembly & Circuit Diagram.....	3-18
Cryoclaw Opto PCB Assembly & Circuit Diagram.....	3-20
D.C. Motor Control PCB Assembly.....	3-21
Elevator Opto PCB Assembly & Circuit Diagram.....	3-22
Motor EMI PCB Assembly.....	3-23
8-Driver PCB Assembly & Circuit Diagram.....	3-24
Coin Door Interface PCB Assembly.....	3-26
Sound Board Interboard Wiring.....	3-28
CPU Board Interboard Wiring.....	3-29
Dot Matrix Controller Board Interboard Wiring.....	3-30
Fliptronic II Board Interboard Wiring.....	3-31
Power Driver Board Interboard Wiring.....	3-32

SECTION 1

Game Operation and Test Information

ROM SUMMARY

IC	Type	Location	Board	Part Number
Game ROM 1 (Domestic)	27c040	U6	CPU	A-5343-50028-1A
Game ROM 1 (Foreign)	27c040	U6	CPU	A-5343-50028-1X
Music/Speech ROM	27c040	SU2	Audio	A-5343-50028-S2
Music/Speech ROM	27c040	SU3	Audio	A-5343-50028-S3
Music/Speech ROM	27c040	SU4	Audio	A-5343-50028-S4
Music/Speech ROM	27c040	SU5	Audio	A-5343-50028-S5
Music/Speech ROM	27c040	SU6	Audio	A-5343-50028-S6
Music/Speech ROM	27c040	SU7	Audio	A-5343-50028-S7

PINBALL GAME ASSEMBLY INSTRUCTIONS

DEMOLITION MAN IS A 5 BALL GAME.

Power: Domestic 120V @ 60Hz
Foreign 230V @ 50Hz
Japan 100V @ 50Hz

Temp: 32°F to 100° F (0°C to 38°C)

Humidity: Not to exceed 95% relative.

Dimensions: Width: 29" approx.
Depth: 52" approx.
Height: 76" approx.

Weight: 334 lbs approx. (crated)

1. Remove all cartons, parts, and other items from the shipping container and set them aside.
2. Leg levelers and leg bolts are among the parts in the cash box. Install leg levelers on the front and rear legs (View 1). Place cabinet on a support and attach rear legs using leg bolts (View 2).
3. Attach front legs using leg bolts (View 2).

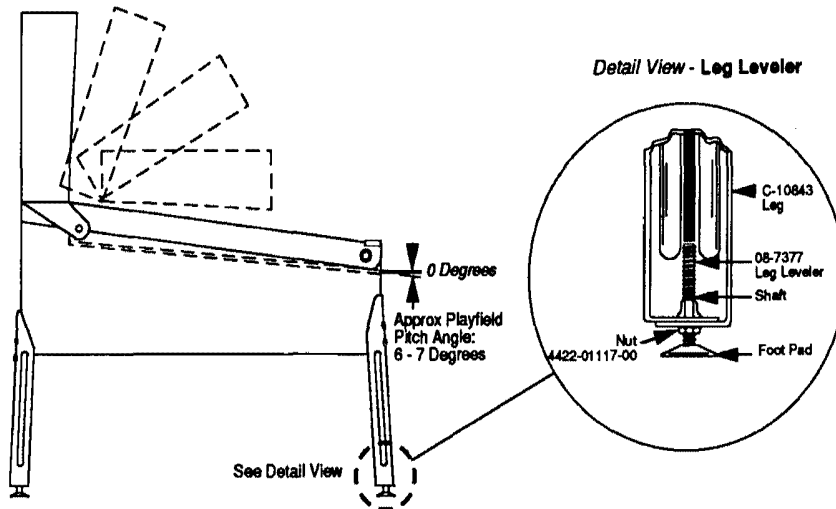

VIEW 1

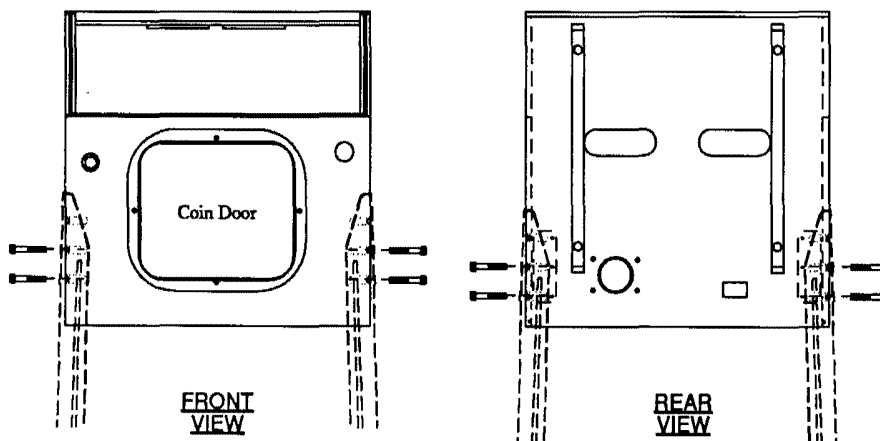

VIEW 2

4. Reach into the cabinet and backbox and ensure that the interconnecting cables are not kinked or pinched. Be careful to avoid damaging wires at any stage of the assembly process.
5. Raise the hinged backbox upright and latch it into position. Unlock the backbox, and remove the backglass. Remove the shipping screws holding the Insert Panel. Unlatch and open the Insert Panel. Carefully lift up the Speaker Panel and lay it down on the playfield glass. (Be careful not to damage the Dot Matrix Display/Driver.) This allows access to the bolt holes used for securing the backbox upright. To secure the backbox, install the washer-head mounting bolts through the bottom holes of the backbox into the threaded fasteners in the cabinet. Close and latch the Insert Panel. Replace the Speaker Panel. Reinstall the backglass, and lock the backbox.

CAUTION

FAILURE TO INSTALL the backbox mounting hardware properly can cause personal injury. **NEVER TRANSPORT** a pinball game with the hinged backbox erect. Always lower the backbox forward onto the playfield cabinet on a layer of protective material to prevent marring or damage and possible personal injury.

6. Extend each leg leveler *slightly* below the leg bottom, so that all four foot pads are extended about the same distance. Remove the cabinet from its support and place it on the floor.
7. Unlock and open the coin door. Move the molding latch lever toward the left side of the game. Lift the front molding off the playfield cover glass return the latch lever toward the right, and close the coin door. Carefully slide the glass downward, until it clears the grooves of the left and right side moldings. Lift the glass up and away from the game, storing it carefully to avoid breakage.
8. Place a level or an inclinometer on the playfield surface. Adjust the leg levelers for proper playfield level (side-to-side). NOTE: This measurement must be made ON the playfield, not the cabinet nor the playfield cover glass. Tighten the nut on each leg leveler shaft to maintain this setting.
9. Adjust the leg levelers to the proper playfield pitch (back-to-front). The recommended pitch level is 6-1/2 degrees.

! IMPORTANT !

Playfield pitch angle can affect the operation of the plumb bob tilt. The plumb bob weight is among the parts in the cash box; the operator should install the weight and adjust this tilt mechanism for proper operation, after completion of the desired playfield pitch angle setting. The unit is factory installed for a 6-1/2 degree angle. If an adjustment is necessary, loosen the screw at the bottom of the unit. Move the pointer, one groove at a time to the left or the right, depending on the degree desired. Hold the pointer in place and tighten screw.

10. Move the game into the desired location; recheck the level and pitch angle of the playfield.
11. Be sure the **required number** of balls are installed. This game uses five balls.
12. Install full playfield mylar, if desired. **NOTE:** The playfield is coated with a special hardcoat surface and does not require a protective mylar. However, mylars can be purchased through your local Williams Distributor. Specify part number 03-9118-1 for full playfield mylar.

13. Remove the foam from the Cryoclaw and pull the two pieces of cardboard from the Car Tunnel.
14. Clean and reinstall the playfield cover glass. Prepare the game for player operation.
15. To attach the line cord, remove the envelope stapled to the inside of the cabinet (near the cashbox). Remove the four Phillips-head screws that mount to line cord cover plate to the rear cabinet. Match the prongs on the plug with the holes in the receptacle, and push the line cord securely into place. Make sure the cord is aligned with the indentation on the cover plate (indentation should point toward bottom of the cabinet). Remount line cord cover plate. If desired, four tamper resistant screws have been provided in an envelope marked "Security Screws" (located in the cashbox) to remount cover plate.

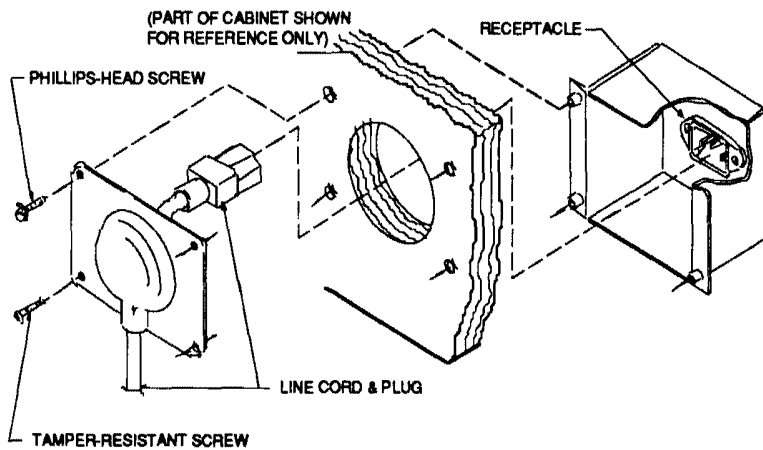

RAISING THE PLAYFIELD

CAUTION

Do not raise the playfield straight up! This game uses a slide assembly to raise and lower the playfield.

To raise the playfield.

1. Grasp bottom arch and carefully lift up playfield only high enough to clear safety brackets. Rear guide legs should not hit wood guide rails or be used to slide out playfield.

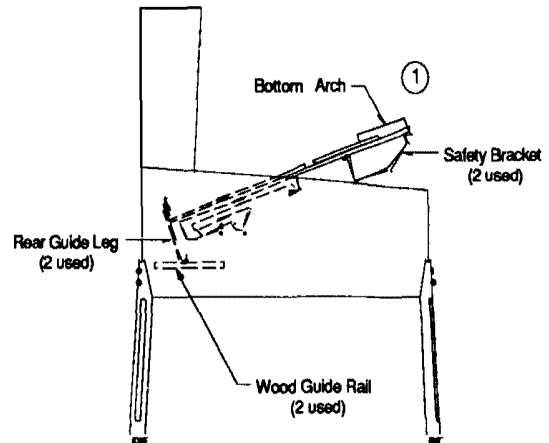

2. Pull the playfield out toward you until it stops (rest position) and raise it approximately 3". Be sure playfield is in locked position and does not slide back into the cabinet. If it does, repeat Step 2 before proceeding to Step 3.
3. Rotate playfield to upright service position (lean on backbox) by pulling toward you and up. Listen for the sound of a click; this insures locking and pivoting sequence.

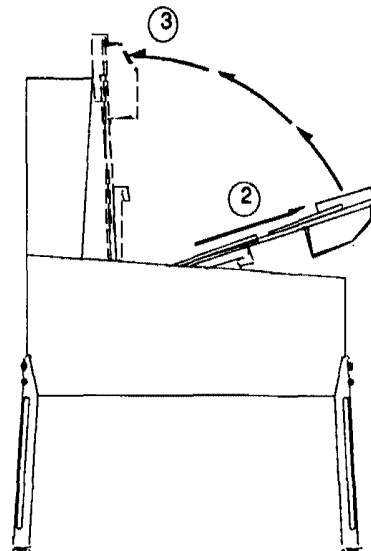

To lower the playfield.

4. Rotate the playfield to the rest position. This unlocks the pivoting mechanism.
5. Push back playfield into cabinet and into playing position.

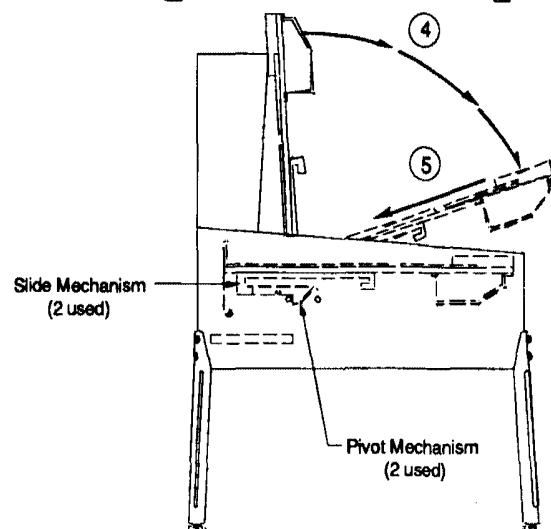

GAME CONTROL LOCATIONS

Cabinet Switches

The On-Off Switch is on the bottom of the cabinet near the right front leg.

The Start Button is a pushbutton to the left of the coin door on the cabinet exterior. Press the Start button to begin a game, or during the diagnostic mode, to ask for HELP.

Coin Door Buttons

The operator controls all game adjustments, obtains bookkeeping information, and diagnoses problems, using only four pushbutton switches mounted on the inside of the coin door. The Coin Door Buttons have two modes of operation Normal Function and Test Function.

Normal Function

The Service Credits button puts credits on the game that are not included in any of the game audits.

The Volume Up (+) button raises the sound level of the game. Press and hold the button until the desired level is reached.

The Volume Down (-) button lowers the sound level of the game. Press and hold the button until the desired level is reached. See Adjustment A.1 28 to shut sound Off completely.

The Begin Test button starts the Menu System Operation and changes the Coin Door Buttons from Normal Function to Test Function.

Test Function

The Escape button allows you to get out of a menu selection or return to the Attract Mode.

The Up (+) button allows you to cycle forward through the menu selections or adjustment choices.

The Down (-) button allows you to cycle backward through the menu selections or adjustment choices.

The Enter button allows you to get into a menu selection or lock in an adjustment choice.

Holding the Enter button for five seconds, during the Attract Mode, resets the High Scores.

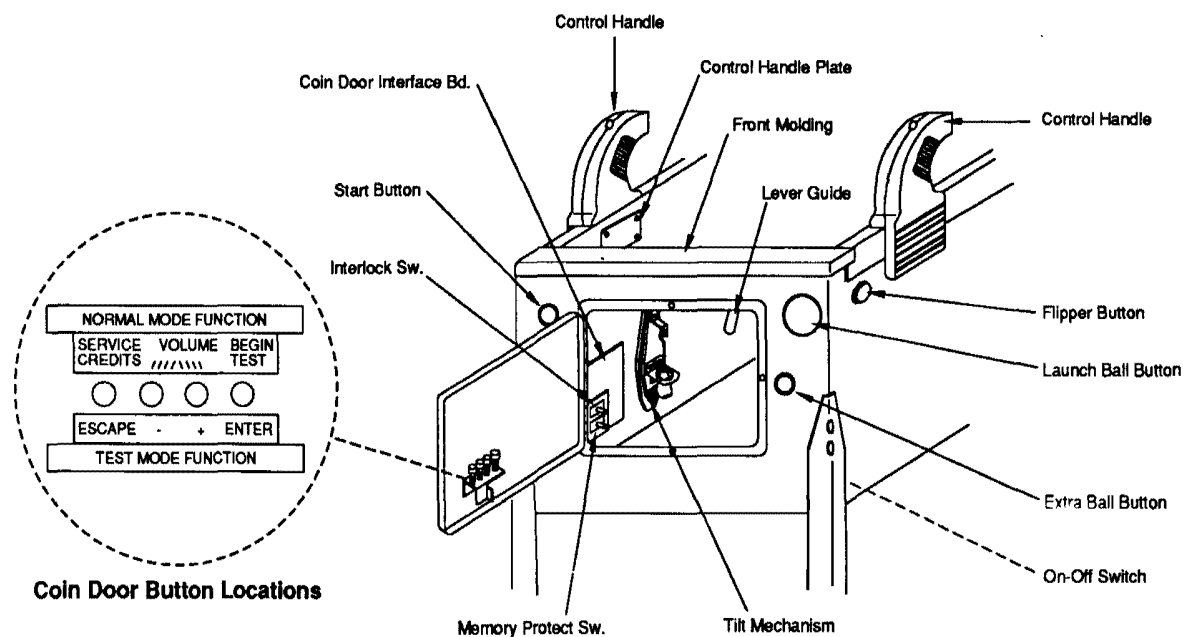

GAME OPERATION

CAUTION

After assembly and installation at its site location, this game must be plugged into a properly grounded outlet to prevent shock hazard, and to assure proper game operation. DO NOT use a 'cheater' plug to defeat the ground pin on the line cord. DO NOT cut off the ground pin.

POWERING UP With the coin door closed, plug the game in, and switch it On. In normal operation, Testing shows in the displays as the game performs Start-up Tests. Once the Start-up Tests have been successfully completed the last score is displayed. After which, the game goes into the Attract Mode.

Note: After the game has been on location for a time, the Start-up Tests may contain messages concerning game problems. The section entitled 'Error Messages' contains more details concerning messages displayed at each game turn-on.

Open the coin door and press the Begin Test switch. The display shows the game name, number, and software revision. The message changes. The display shows the sound software revision, the revision level of the system software, and the date the software was revised.

Example:

	Game Name	Sound Rev. L-1
500XX	Rev. L-X	SY. 0.X0 X-X-94

Press the Enter button to enter the WPC Menu System (refer to the section entitled "Menu System Operation" for more information). Slide the Service Switch Actuator over the top interlock switch located in the bottom left corner of the coin door opening. Perform the entire Test Menu routine to verify that the game is operating satisfactorily.

ATTRACT MODE*. After completing the Test Menu routine, press the Escape button three times to enter the Attract Mode. During the Attract Mode, the score display shows a series of messages informing the player concerning, recent highest scores*, "custom messages*", and the score to achieve to obtain a Replay award*.

CREDIT POSTING. Insert coin(s). A sound is heard for each coin, and the display shows the number of credits purchased. So long as the number of maximum allowable credits* are NOT exceeded by coin purchase or high score, credits are posted correctly.

STARTING A GAME. Press the Start button. A startup sound plays, and the credit amount shown in the display decreases by one. The display flashes 00 (until the first playfield switch is actuated), and shows ball 1. If credits are posted, additional players may enter the game by pressing the Start button once for each player, before the end of play on the first ball. Press the handle buttons or the Launch Ball button to launch a ball. Press the handle triggers or the flipper buttons to operate the flippers.

TILTS. Actuating the cabinet tilt switch inside the cabinet ends the current game and then proceeds to the Game Over Mode. With the third closure* of the plumb bob tilt switch, the player loses the remaining play of that ball, but can complete the game.

END OF A GAME. All earned scores and bonuses are awarded. If a player's final score exceeds the specified value, the player receives a designated award for achieving the current highest score. A random digit set* appears in the display. Credit* may be awarded, when the last two digits of any player's score match the random digits. Match, high score, and game over sounds are made, as appropriate.

GAME OVER MODE. The Game Over display shows in the display. Then, the high scores flash. The game proceeds to the Attract Mode.

* - Operator-adjustable feature

MENU SYSTEM OPERATION

The Main Menu allows you to choose from several categories, which in turn lead to other menus to choose from. To access the Main Menu, open the coin door and press the Begin Test button, then press the Enter button. Press the Up or Down buttons to cycle through the Main Menu. Press the Enter button to access a menu. Press the Escape button to return to the Main Menu. Press the Start button for HELP at any time.

MAIN MENU

B. Bookkeeping Menu

- _____ B.1 Main Audits
- _____ B.2 Earning Audits
- _____ B.3 Standard Audits
- _____ B.4 Feature Audits
- _____ B.5 Histograms
- _____ B.6 Time-stamps

P. Printouts Menu

- _____ P.1 Earnings Data
- _____ P.2 Main Audits
- _____ P.3 Standard Audits
- _____ P.4 Feature Audits
- _____ P.5 Score Histograms
- _____ P.6 Time Histograms
- _____ P.7 Time-Stamped
- _____ P.8 All Data

T. Test Menu

- _____ T.1 Switch Edges Test
- _____ T.2 Switch Levels Test
- _____ T.3 Single Switches Test
- _____ T.4 Solenoid Test
- _____ T.5 Flasher Test
- _____ T.6 General Illumination Test
- _____ T.7 Sound and Music Test
- _____ T.8 Single Lamps Test
- _____ T.9 All Lamps Test
- _____ T.10 Lamp & Flasher Test
- _____ T.11 Display Test
- _____ T.12 Flipper Coil Test
- _____ T.13 Ordered Lamps Test
- _____ T.14 Claw Test
- _____ T.15 Empty Balls Test

U. Utilities Menu

- _____ U.1 Clear Audits
- _____ U.2 Clear Coins
- _____ U.3 Reset H.S.T.D.
- _____ U.4 Set Time & Date
- _____ U.5 Custom Message
- _____ U.6 Set Game I.D.
- _____ U.7 Factory Adjustments
- _____ U.8 Factory Resets
- _____ U.9 Presets
- _____ U.10 Clear Credits
- _____ U.11 Auto Burn-in

A. Adjustments Menu

- _____ A.1 Standard Adjustments
- _____ A.2 Feature Adjustments
- _____ A.3 Pricing Adjustments
- _____ A.4 H.S.T.D. Adjustments
- _____ A.5 Printer Adjustments

Press Escape

To move out of a menu selection.

Press Enter

To get into a menu selection.

Press Up

Increases sequence; (ex. A.1 A.2, A.3, A.4).

Press Down

Decreases sequence; (ex. A.4, A.3, A.2, A.1).

Use Up or Down to cycle through the selections in a menu.

Use Escape and Enter to move into and out of the selected menu.

Press the Up or Down buttons to cycle through the menu. Press the Enter button to access an audit menu. Press the Escape button to return to the Bookkeeping Menu.

B. BOOKKEEPING MENU

- B.1 Main Audits**
- B.2 Earning Audits**
- B.3 Standard Audits**
- B.4 Feature Audits**
- B.5 Histograms**
- B.6 Time-Stamps**

One Button Audit System. The Bookkeeping Menu is obtainable directly from the Attract Mode. Repeatedly pressing the Enter button, while in the Attract Mode, will cycle through all of the game audits.

B.1 Main Audits

B.1	01	Total Earnings	00
B.1	02	Recent Earnings	00
B.1	03	Free Play Percent	00
B.1	04	Average Ball Time	00
B.1	05	Time Per Credit	00
B.1	06	Total Plays	00
B.1	07	Replay Awards	00
B.1	08	Percent Replays	00
B.1	09	Extra Balls	00
B.1	10	Percent Extra Ball	00

B.2 Earning Audits

B.2	01	Recent Earnings	00
B.2	02	Recent Left Slot	00
B.2	03	Recent Center Slot	00
B.2	04	Recent Right Slot	00
B.2	05	Recent 4th Slot	00
B.2	06	Recent Paid Credits	00
B.2	07	Recent Service Credits	00
B.2	08	Total Earnings*	00
B.2	09	Total Left Slot*	00
B.2	10	Total Center Slot*	00
B.2	11	Total Right Slot*	00
B.2	12	Total 4th Slot*	00
B.2	13	Total Paid Credits*	00
B.2	14	Total Service Credits*	00

* These audits are NOT resettable. They are a record of the earnings of the game since the "CLOCK 1ST SET" Time-stamp.

B.3 Standard Audits

B.3	01	Games Started	00
B.3	02	Total Plays*	00
B.3	03	Total Free Play	00
B.3	04	Free Play Percent	00
B.3	05	Replay Awards	00
B.3	06	Percent Replays	00
B.3	07	Special Awards	00
B.3	08	Percent Special	00
B.3	09	Match Awards	00
B.3	10	Percent Match	00
B.3	11	H.S.T.D. Credits	00
B.3	12	Percent H.S.T.D	00
B.3	13	Extra Ball	00
B.3	14	Percent Extra Ball	00
B.3	15	Tickets Awarded	00
B.3	16	Percent Tickets	00
B.3	17	Left Drains	00
B.3	18	Right Drains	00
B.3	19	Average Ball Time	00
B.3	20	Average Game Time	00
B.3	21	Play Time	00:00:00
B.3	22	Minutes On	00
B.3	23	Balls Played	00
B.3	24	Tilts	00
B.3	25	Replay 1 Awards	00
B.3	26	Replay 2 Awards	00
B.3	27	Replay 3 Awards	00
B.3	28	Replay 4 Awards	00
B.3	29	1 Player Games	00
B.3	30	2 Player Games	00
B.3	31	3 Player Games	00
B.3	32	4 Player Games	00
B.3	33	H.S.T.D. Reset Count	00
B.3	34	Burn-in Time†	00:00:00
B.3	35	1st Replay Level	00
B.3	36	Left Flipper	00
B.3	37	Right Flipper	00

* "Total Plays" only counts on completed games. A game is considered complete when the final ball begins. Audit information from incomplete games is ignored. Operation for test and service do not affect audits.

† This audit is not resettable.

B.4 Feature Audits

B.4 01	Buy-in Extra Balls	Number of times player bought an extra ball	00%	00
B.4 02	Time per Credit	Average number of minutes player/credit paid	00%	00
B.4 03	Combo 1st Extra Ball	Number of times 1st extra ball lit from Combo	00%	00
B.4 04	Combo 2nd Extra Ball	Number of times 2nd extra ball lit from Combo	00%	00
B.4 05	Bonus X Extra Ball	Number of times extra ball lit from Bonus X	00%	00
B.4 06	Computer Extra Ball	Number of times extra ball lit from Computer	00%	00
B.4 07	Total Multiballs	Total number of multiballs played	00%	00
B.4 08	1st Multiballs	Number of 1st multiballs played	00%	00
B.4 09	2nd Multiballs	Number of 2nd multiballs played	00%	00
B.4 10	3rd Multiballs	Number of 3rd multiballs played	00%	00
B.4 11	4th Multiballs	Number of 4th multiballs played	00%	00
B.4 12	Computer Awards	Number of computer awards	00%	00
B.4 13	Ball Saves	Number of times the ball was saved	00%	00
B.4 14	Jackpots	Number of jackpots collected	00%	00
B.4 15	Super Jackpots	Number of super jackpots collected	00%	00
B.4 16	Combos	Number of Combos made	00%	00
B.4 17	Big Combos	Number of 4-way and higher Combos made	00%	00
B.4 18	Claw Visits	Number of times the Cryoclaw was visited	00%	00
B.4 19	Claw Opened	Number of times the Cryoclaw was opened	00%	00
B.4 20	Capture Simon	Number of times Capture Simon selected	00%	00
B.4 21	Super Jets	Number of times Super Jets selected	00%	00
B.4 22	Prison Break	Number of times Prison Break selected	00%	00
B.4 23	Claw Freezes	Number of times Freeze selected	00%	00
B.4 24	AcMags	Number of times AcMag selected	00%	00
B.4 25	Double Prison Break	Number of times Prison Break doubled	00%	00
B.4 26	Triple Prison Break	Number of times Prison Break tripled	00%	00
B.4 27	5-ball Multiballs	Number of times 5-ball Multiball was played	00%	00
B.4 28	Quick Freezes	Number of times Quick Freeze was made	00%	00
B.4 29	Left Ramps	Number of times the left ramp was made	00%	00
B.4 30	Right Ramps	Number of times the right ramp was made	00%	00
B.4 31	Center Ramps	Number of times the center ramp was made	00%	00
B.4 32	Side Ramps	Number of times the side ramp was made	00%	00
B.4 33	Bonus X	Number of times the Bonus X was boosted	00%	00
B.4 34	Car Crashes	Number of times the car crash award collected	00%	00
B.4 35	Eyeball Hits	Number of times the eyeball target was hit	00%	00
B.4 36	Explode Hurry-up	Number of times Explode Hurry-up mode started	00%	00
B.4 37	Standup Complete	Number of times standup targets completed	00%	00
B.4 38	Demolition Time	Number of times Demolition Time started	00%	00
B.4 39	D. Time Champ Credits	Number of credits award for Demo Time Champ	00%	00
B.4 40	Secret Features	Number of secret features activated	00%	00
B.4 41	Left Handle	Number of times the left handle trigger was used to flip flippers	00%	00
		Note that the standard audit B.3 36 Left Flipper includes flips made by BOTH flipper button and handle trigger.		
B.4 42	Right Handle	Number of times the right handle trigger was used to flip flippers	00%	00
		Note that the standard audit B.3 37 Right Flipper includes flips made by BOTH the flipper button and the handle trigger.		

B.5 Histograms

B.5	01	0-1.9 Million Scores	00%	00
B.5	02	2-4.9 Million Scores	00%	00
B.5	03	5-9.9 Million Scores	00%	00
B.5	04	10-19 Million Scores	00%	00
B.5	05	20-29 Million Scores	00%	00
B.5	06	30-39 Million Scores	00%	00
B.5	07	40-49 Million Scores	00%	00
B.5	08	50-69 Million Scores	00%	00
B.5	09	70-99 Million Scores	00%	00
B.5	10	100-149 Million Scores	00%	00
B.5	11	150-199 Million Scores	00%	00
B.5	12	200-299 Million Scores	00%	00
B.5	13	Over 300 Million Scores	00%	00
B.5	14	Game Time 0.0-1.0 Mins	00%	00
B.5	15	Game Time 1.0-1.5 Mins	00%	00
B.5	16	Game Time 1.5-2.0 Mins	00%	00
B.5	17	Game Time 2.0-2.5 Mins	00%	00
B.5	18	Game Time 2.5-3.0 Mins	00%	00
B.5	19	Game Time 3.0-3.5 Mins	00%	00
B.5	20	Game Time 3.5-4.0 Mins	00%	00
B.5	21	Game Time 4-5 Mins	00%	00
B.5	22	Game Time 5-6 Mins	00%	00
B.5	23	Game Time 6-8 Mins	00%	00
B.5	24	Game Time 8-10 Mins	00%	00
B.5	25	Game Time 10-15 Mins	00%	00
B.5	26	Game Time Over 15 Mins	00%	00

B.6 Time-Stamps

Time-Stamps Menu allows you to view dates and times that are important to game software.

B.6	01	Current Time
B.6	02	Clock 1st Set
B.6	03	Clock Last Set
B.6	04	Audits Cleared
B.6	05	Coins Cleared
B.6	06	Factory Setting
B.6	07	Last Game Start
B.6	08	Last Replay
B.6	09	Last H.S.T.D. Reset
B.6	10	Champion Reset
B.6	11	Last Printout
B.6	12	Last Service Credit

Press the Up or Down buttons to cycle through the menu. Press the Enter button to access a menu. Press the Escape button to return to the Printouts Menu.

P. PRINTOUTS MENU

(optional board required)

- P.1 Earnings Data**
- P.2 Main Audits**
- P.3 Standard Audits**
- P.4 Feature Audits**
- P.5 Score Histograms**
- P.6 Time Histograms**
- P.7 Time-Stamps**
- P.8 All Data**

The Printouts Menu is a combination of the other menus. This menu allows you to access and print information in the available menu selections.

If no printer is attached the the message "Waiting for Printer" appears in the displays.

NOTE: Set the print specification from the Adjustment Menu, A.5 Printer Adjustments.

Use the Service Switch Actuator to hold in the top interlock switch located in the bottom left corner of the coin door opening. The actuator must be in place in order to activate the solenoids and flashlamps.

Press the Up or Down buttons to cycle through the menu. Press the Enter button to access a test. Press the Escape button to return to the Test Menu. **NOTE:** During any test, press the Start button to obtain the wire color, driver number, connector number and fuse location.

T. TEST MENU

- T.1 Switch Edges Test**
- T.2 Switch Levels Test**
- T.3 Single Switch Test**
- T.4 Solenoid Test**
- T.5 Flasher Test**
- T.6 General Illumination Test**
- T.7 Sound & Music Test**
- T.8 Single Lamps Test**
- T.9 All Lamps Test**
- T.10 Lamp & Flasher Test**
- T.11 Display Test**
- T.12 Flipper Coil Test**
- T.13 Ordered Lamps Test**

The switch matrix, on the left side of the display, shows the state of all switches. A dot indicates the switch is open, a square indicates the switch is closed. The numbers assigned to each switch indicate where the switch is located in the matrix. The number on the left indicates the column, the number on the right indicates the row. Example - Switch 23 is 2nd column, 3rd row.

A short to ground - on either the row or column wire - appears as a shorted row(s). However, a column wire shorted to ground disappears when all of the indicated row switches are open. A row wire shorted to ground does not disappear.

A shorted diode in the switch matrix can cause other switches to appear closed. These "phantom" switches (though not actually closed), complete a rectangle in the switch matrix. Therefore, if two switches in the same column are closed (example; #22 and #24), and a third switch is pressed in another column but in the same row as one of the first two (example; #32), the "phantom" switch #34 is falsely indicated as closed. The switch with the shorted diode is diagonally opposite the "phantom" switch (in this case #22).

- T.1 Switch Edges Test** Press each switch one at a time. The name and number of the switch is shown in the display. If a switch other than the one pressed, or no switch at all is indicated, the system has detected a problem with the switch circuit.
- T.2 Switch Levels Test** This test automatically cycles through all switches that are detected closed. The name and number of each switch that is detected is shown in the display. A filled square indicates the switch's position in the matrix.
- T.3 Single Switches Test** The Single Switch Test isolates a particular switch by blocking signals from all other switches. Use the Up or Down buttons to select the switch to be tested.

T.4 Solenoid Test The Solenoid Test has three modes - Repeat, Stop, and Run. Only one solenoid should pulse at a time. The system has detected a problem if more than one solenoid pulses, a solenoid comes on and stays on, or no solenoids pulse during the Repeat or Run modes.

Repeat The Repeat mode pulses a single solenoid. After entering this test, Solenoid 1 shows in the display and the corresponding solenoid activates. Press the Up or Down button to cycle through the solenoids, one at a time. The same solenoid pulses until the Up or Down button is pressed. Either press the Escape button to return to the Test Menu, or press the Enter button to move to the next mode.

Stop The Stop mode halts the Solenoid Test. Press Enter during the Repeat mode and the Solenoid Test stops. No solenoids should be activated while the test is stopped. Either press the Escape button to return to the Test Menu, or the Enter button to move to the next mode.

Run The Run mode cycles through the solenoids automatically. The display shows the name and number of the solenoid currently being pulsed.

T.5 Flasher Test This tests the flashlamp part of the solenoid circuit exclusively. This, like the Solenoid Test, has three modes - Repeat, Stop, and Run. During this test only one flashlamp circuit should pulse at a time. The system has detected a problem if more than one circuit pulses, a circuit stays on, or no circuits pulse during the Repeat or Run modes.

Repeat The Repeat mode pulses a single flashlamp. After entering this test the name and number of the first flashlamp circuit shows in the display and the corresponding bulb(s) flash. Press the Up or Down buttons to cycle through all of the flashlamps circuits one at a time. The same circuit pulses until press the Up or Down button is pressed. Either press the Escape button to return to the Test Menu, or press the Enter button to advance to the next mode.

Stop The Stop mode halts the Flasher Test. No flashlamp circuit should be active during this mode. Either press the Escape button to return to the Test Menu, or press the Enter button to advance to the next mode.

Run The Run mode cycles through the flashlamps automatically. The display shows the name and number of the flashlamp circuit currently being pulsed as the corresponding bulb(s) flashes.

T.6 General Illumination Test This test checks all of the General Illumination circuits. There are two modes of operation - Stop and Run.

Stop Press the Up or Down buttons to cycle through the General Illumination Test manually. All illumination is tested first, followed by an individual circuit test. The circuit name and number shows in the display while the corresponding lamps lights. If any other results occur the system has detected an error.

Run Press the Enter button any time during Stop mode and the General Illumination Test cycles through automatically. For each circuit shown in the display the corresponding bulbs should light. If any other results occurs the system has detected a problem.

T.7 Sound and Music Test The Sound and Music Test checks the audio circuits. This test has three modes for testing the sound and music circuits - Run, Repeat, and Stop.

Run The Run mode steps through a sequence of sounds and music. Press the Up or Down buttons during this portion of the Sound and Music test to advance to a particular sound or tune without having to wait for the program to play all the sounds available in the test. A sound or tune should be heard for each name and number that appears in the display. Any other results indicates the system has detected a problem.

Repeat Press the Enter button at any time during the Run mode to cause the program to stop and repeat a particular sound/tune. The same sound should repeat continuously until the Up or Down button is pressed. Any other results indicates the system has detected a problem.

Stop Press the Enter button at any time during the Repeat mode to stop this test altogether. Nothing should be heard. Any other results indicates the system has detected a problem.

T.8 Single Lamp Test The number assigned to each lamp indicates the lamp's position in the matrix. The number on the left indicates the column. The number on the right indicates the row. Example - Lamp 23 means 2nd column, 3rd row.

This test checks each lamp circuit individually. Press the Up or Down button to cycle through this test. For each name and number that is shown in the display the corresponding lamp should light. Any other results indicates the system has detected a problem.

T.9 All Lamps Test This test causes all the controlled lamps to flash at the same time. Every controlled lamp should flash. Any other results indicates the system has detected a problem.

T.10 Lamp and Flasher Test This test causes all the flashlamps and the controlled lamps to flash at the same time. The controlled lamps blink, while the flashlamps cycle from highest to lowest. Any other results indicates the system has detected a problem.

T.11 Display Test This test automatically checks every dot in the Dot Matrix Display. A series of patterns appear in sequence. Each pattern turns on and off a section of dots. Every dot on the matrix display should be turned on and off during this test.

T.12 Flipper Coil Test The Flipper Coil Test has three modes - Repeat, Stop, and Run. Only one Flipper should pulse at a time. The system has detected a problem if more than one flipper pulses, a flipper comes on and stays on, or no flippers pulse during the Repeat or Run modes.

Repeat The Repeat mode pulses a single flipper. After entering this test, flipper coil 01 shows in the display and the corresponding coil activates. Press the Up or Down button to cycle through the flipper coils, one at a time. The same solenoid pulses until the Up or Down button is pressed. Either press the Escape button to return to the Test Menu, or press the Enter button to move to the next mode.

T.12 Flipper Coil Test Continued...

Stop The Stop mode halts the Flipper Coil Test. Press Enter during the Repeat mode and the test stops. No coils should be activated while the test is stopped. Either press the Escape button to return to the Test Menu, or the Enter button to move to the next mode.

Run The Run mode cycles through the flippers automatically. The display shows the name and number of the flipper coil currently being pulsed.

T.13 Ordered Lamps Test The number assigned to each lamp indicates the lamp's position in the matrix. The number on the left indicates the column. The number on the right indicates the row. Example - Lamp 23 means 2nd column, 3rd row.

This test checks each lamp circuit individually. Press the Up or Down button to cycle through the lamps. Lamps light in a clock-wise or counter clock-wise direction starting from the bottom of the playfield. Direction depends on which button, Up or Down, is pressed. For each name and number that is shown in the display the corresponding lamp should light. Any other results indicates the system has detected a problem.

T.14 Claw Test The Claw test aids in troubleshooting the Cryoclaw/Elevator mechanism. The claw test provides several functions for activating the mechanism, while simultaneously displaying the states of the opto switches associated with the mechanism. For more information on claw operation, see Theory of Operation.

Switch display -

The states of the following switches are constantly monitored and displayed during the Claw test: Elevator Index, Elevator Hold, Claw Left, Claw Right. The box next to each switch name contains an X when the switch is activated (blocked).

Claw Test Functions

Use the diagnostic Up and Down buttons to step through the available Claw test functions. The functions operate only when the diagnostic Enter button is pressed. When a function is active its name is inverted on the display screen. To stop claw function at any time simply release the Enter button.

Auto Run

During the Auto Run function the elevator is continuously monitored for the presence of a pinball. When a ball is placed on the platform the test cycles the claw and the elevator causing the ball to be picked up by the claw magnet and dropped on the far left ramp.

Claw Left

The Claw Left function moves the claw arm to the left (away from the elevator). This function does not move the arm out of range.

Claw Right

The Claw Right function moves the claw arm to the right (toward the elevator). This function does not move the arm out of range.

To move the claw arm when it is out of range select Claw Left or Claw Right, as appropriate, and hold in either flipper button before pressing Enter. Do not move the claw arm by hand.

Run Elevator

The Run Elevator function runs the elevator motor continuously.

Park Elevator

The Park Elevator function runs the elevator motor until the elevator index position is detected. The motor is then shut off.

Magnet On

The Magnet On function turns on the claw magnet. The magnet is turned on solidly for a short period and then pulsed for a longer period. The Magnet On function times out after several seconds and shuts off the magnet to avoid overheating it.

Claw Test Error Messages

During the various claw test functions the CPU may detect an error condition. The messages are explained below.

Elevator Error

The Claw test displays this message when the elevator motor is running and the elevator index switch is not detected after several seconds.

Claw Out of Range

The Claw test displays this message when it detects that the claw arm is out of range (see Theory of Operation later in this section).

To move the claw arm when it is out of range select Claw Left or Claw Right, as appropriate, and hold in either flipper button before pressing Enter. Do not move the claw arm by hand.

Claw Movement Error

The Claw test displays this message when the claw motor is running and neither position switch is detected after several seconds.

Magnet Error

The Claw test displays this message after it has tried several times to pick up the ball from the elevator.

T.15 Empty Balls Test The Empty Balls test clears all balls from any lock-up device, including the outhole trough. Press the Enter button to begin the test and the Escape button to stop it.

Press the Up or Down buttons to cycle through the menu. Press the Enter button to access a utility. Press the Up or Down buttons to see the setting choices. Press the Enter button to lock in a choice. If a mistake is made, press Escape while "Saving Adjustment Value" is in the display. The original setting is retained and the new setting is ignored. Press the Escape button to return to the Utility Menu.

U. Utilities Menu

- U.1 Clear Audits**
- U.2 Clear Coins**
- U.3 Reset H.S.T.D.**
- U.4 Set Time & Date**
- U.5 Custom Message**
- U.6 Set Game I.D.**
- U.7 Factory Adjustments**
- U.8 Factory Resets**
- U.9 Presets**
- U.10 Clear Credits**
- U.11 Auto Burn-In**

U.1 Clear Audits Press the Enter button to clear the Standard Audits (except Burn-in Time), Feature Audits, and Histograms.

U.2 Clear Coins Press the Enter button to clear the Earnings Audits.

U.3 Reset H.S.T.D. Press the Enter button to clear the High Score to Date Table and the Grand Champion.

U.4 Set Time and Date Press the Enter button to activate the time and date. Use the Up or Down button to change the value, then press the Enter button to lock in that value. If a mistake is made press the Escape button while "Saving Adjustment Value" is displayed. The new value is ignored and the original value is retained.

U.5 Custom Message *Set A.1 20 to ON before trying to write a Custom Message.* Press the Enter button to begin entry of the custom message. Use the Up or Down buttons to cycle through letters. Use the Start button to cycle through punctuation marks. Press the Enter button to lock in the desired letter and punctuation. If a mistake is made, use Up and Down to select the "back-arrow" character. The "back-arrow" character is located before the space character and after the number nine. Press Enter while the back-arrow shows to erase the previously entered character. Once the message is complete, press and hold the Enter button until "Message Stored" is displayed.

Press the Escape button to cancel the new message. The message "Press Enter to Reset" appears. If Enter is pressed, the custom message is cleared and no message is displayed. If Escape is pressed, the original message remains intact.

U.6 Set Game I.D. This utility allows for the installation of a message, such as game location, that only appears on printouts. Press the Enter button to activate Set Game I.D.. Use the Up or Down buttons to cycle through letters. Use the Start button to cycle through punctuation marks. Press the Enter button to lock in the desired letter and punctuation.

U.7 Factory Adjustment Press the Enter button to restore the adjustments to factory settings.

U.8 Factory Reset Press the Enter button to restore the adjustments to their factory setting, clear the Audits, H.S.T.D Table, and Custom Message/Game I.D.

U.9 Presets Use the Up or Down buttons to cycle through the available Presets. When the desired Preset is displayed, press the Enter button to lock in that Preset. If a mistake is made, press the Escape button while "Saving Adjustment Value" is displayed. The new value is ignored and the original value is retained.

Game Difficulty Levels The game play difficulty adjustments can be changed to a combination that is MUCH LESS to MUCH MORE difficult than Factory Settings. The Game Difficulty Setting Table lists the adjustments and settings that comprise the individual group.

- U.9 01 Install Extra Easy**
MUCH LESS difficult than factory setting.
- U.9 02 Install Easy**
Somewhat LESS difficult than factory setting.
- U.9 03 Install Medium**
About the SAME as factory setting.
- U.9 04 Install Hard**
Somewhat MORE difficult than factory setting.
- U.9 05 Install Extra Hard**
MUCH MORE difficult than factory setting.

**Difficulty Setting Table for
U.S., Canadian, French, German, and European Games**

Adj #	Adj Description	Extra Easy U.9 01	Easy U.9 02	Medium U.9 03 (factory)	Hard U.9 04	Extra Hard U.9 05
A.2 02	Ball Saves	2	2	1	1	0
A.2 03	Ball Save Time	11	9	9	5	---
A.2 11	Claw Difficulty	Ex. Easy	Easy	Easy	Medium	Hard
A.2 12	Quick Freeze Difficulty	Medium	Medium	Medium	Medium	Hard
A.2 13	Combo For Computer	8	9	10	12	14

- U.9 06 Install 5 Ball**
- U.9 07 Install 3 Ball** Adjustments U.9 06 and U.9 07 can be used to change a game to 3 or 5 ball play, including changing of certain features to the recommended 3- and 5-ball level. The Preset Game Adjustments Table for U.S./Canadian Games lists the adjustments and settings that comprise the individual groups.

Preset Adjustments Table for U.S. and Canadian Games

Adj #	Adj Description	Install 5-ball U.9 06	Install 3-ball U.9 07
A.1 01	Balls Per Game	5	3
A.1 07	Replay Start	500,000,000	350,000,000
A.2 02	Ball Saves	1	1
A.2 03	Ball Save Time	5	9
A.2 06	1st Ex. Ball Level	18	12
A.2 11	Claw Difficulty	Medium	Easy
A.2 12	Quick Freeze Difficulty	Medium	Medium
A.2 13	Combos for Computer	12	10

U.9 08 Install Add-A-Ball This option deletes all Free Play awards and replaces them with Extra Ball awards. Individual adjustments are affected, as follows:

<u>Ad</u>	<u>Name</u>	<u>New Setting</u>
A.1 13	Replay Boost	Off
A.1 14	Replay Award	Ex. Ball
A.1 15	Special Award	Ex. Ball
A.1 17	Extra Ball Ticket	No
A.1 19	Match Feature	Off
A.2 17	Demo. Time Credits	00
A.4 04	Champion Credits	00
A.4 05	High Score 1 Credits	00
A.4 06	High Score 2 Credits	00
A.4 07	High Score 3 Credits	00
A.4 08	High Score 4 Credits	00

U.9 09 Install Ticket This option deletes Credit awards and replaces them with Ticket awards. Individual adjustments are affected as follows:

<u>Ad</u>	<u>Name</u>	<u>New Setting</u>
A.1 14	Replay Award	Ticket
A.1 15	Special Award	Ticket
A.1 16	Match Award	Ticket
A.1 17	Ex. Ball Ticket	Yes
A.1 31	Ticket Expan.Brd.	Yes
A.4 02	H.S.T.D. Award	Ticket

U.9 10 Install Novelty This option removes all Free Play and Extra Ball awards. Individual adjustments are affected as follows:

<u>Ad</u>	<u>Name</u>	<u>New Setting</u>
A.1 04	Max. Ex. Ball	Off
A.1 05	Replay System	Fixed
A.1 09	Replay Level 1	Off
A.1 10	Replay Level 2	Off
A.1 11	Replay Level 3	Off
A.1 12	Replay Level 4	Off
A.1 15	Special Award	Points
A.1 19	Match Feature	Off
A.2 17	Demo. Time Credits	00
A.4 01	Highest Score	On
A.4 04	Champion Credits	00
A.4 05	High Score 1 Credits	00
A.4 06	High Score 2 Credits	00
A.4 07	High Score 3 Credits	00
A.4 08	High Score 4 Credits	00

U.9 12 Serial Capture This sets up the printer adjustments for a serial transmission to a laptop computer, (9600 baud, 40 column, no page breaks, serial printer). This option requires the installation of the optional printer kit; part number 63110.

U.9 13 through U.9 16 Not Used

- U.9 17 Install German 1 •
- U.9 18 Install German 2 •
- U.9 19 Install German 3 •
- U.9 20 Install German 4 •
- U.9 21 Install German 5 •
- U.9 22 Install German 6 •

Adjustments U.9 17 through U.9 22 are used to modify game pricing and type of game play. The Preset Game Adjustments Table for German/European Games lists the adjustments and settings that comprise the individual groups. **NOTE:** German replay starts at 500,000,000.

Preset Adjustments Table for German Games

Adj #	Adj Description	German 1 U.9 17	German 2 U.9 18	German 3 U.9 19	German 4 U.9 20	German 5 U.9 21	German 6 U.9 22
A.1 14	Replay Award	Credit	Ticket	Audit	Credit	Ticket	Audit
A.1 15	Special Award	Credit	Ex. Ball	Points	Credit	Ex. Ball	Points
A.1 16	Match Award	Credit	Ticket	Credit	Credit	Ticket	Credit
A.1 19	Match Feature	7%	7%	Off	7%	7%	Off
A.3 01	Game Pricing	6spiele/5DM	6spiele/5DM	6spiele/5DM	7spiele/5DM	7spiele/5DM	7spiele/5DM
A.4 02	H.S.T.D. Award	Credit	Ticket	Credit	Credit	Ticket	Credit
A.4 04	Champion Credits	03	03	00	03	03	00
A.4 05	H.S.T.D. 1 Credits	01	01	00	01	01	00
A.4 06	H.S.T.D. 2 Credits	00	00	00	00	00	00
A.4 07	H.S.T.D. 3 Credits	00	00	00	00	00	00
A.4 08	H.S.T.D. 4 Credits	00	00	00	00	00	00

• German DIP Switch settings are: Sw4 Sw5 Sw6 Sw7 Sw8
On On On On Off

- U.9 23 Install French 1*
- U.9 24 Install French 2*
- U.9 25 Install French 3*
- U.9 26 Install French 4*
- U.9 27 Install French 5*
- U.9 28 Install French 6*

Adjustments U.9 23 through U.9 28 are used to modify game pricing and type of play.

* French DIP Switch settings are: Sw4 Sw5 Sw6 Sw7 Sw8
On On On Off Off

U.10 Clear Credits Press the Enter button to clear the game Credits.

U.11 Auto Burn-in Press the Enter button to activate Auto Burn-in. This utility automatically cycles through several tests. This helps in finding intermittent problems. The tests that Auto Burn-in cycles through are: the Display Test, the Sound and Music Test, the All Lamps Test, the Solenoid Test, the Flashers Test, the General Illumination Test, and the Flipper Coil Test. All of the test run are run concurrently. The time spent on the burn-in cycle, and the total time the game has spent in burn-in are displayed.

Press the Up or Down buttons to cycle through the menu. Press the Enter button to access an adjustment. Press the Up or Down buttons to see the setting choices. Press the Enter button to lock in a setting choice. If a mistake is made, press the Escape button while "Saving Adjustment Value" is in the display. The original value is retained and the new value is ignored. Press the Escape button to return to the Adjustment Menu.

A. ADJUSTMENTS MENU

- A.1 Standard Adjustments**
- A.2 Feature Adjustments**
- A.3 Pricing Adjustments**
- A.4 H.S.T.D Adjustments**
- A.5 Printer Adjustments (optional board required)**

A.1 Standard Adjustments

- A.1 01 Balls Per Game**
A "game" is defined by specifying the number of balls to be played.
Range: 1 to 10.

- A.1 02 Tilt Warnings**
The number of total actuations of the plumb bob mechanism that can occur before the game is "tilted".
Range: 1 to 10.

- A.1 03 Maximum Extra Balls**
The number of Extra Balls that a player may accumulate.
Range: 0 to 10.

- A.1 04 Maximum Extra Balls/Ball in Play**
The number of Extra Balls to be awarded per ball in play.

OFF - No maximum number of Extra Ball per ball in play.
1-10 - 1 through 10 Extra Balls per ball in play.

- A.1 05 Replay System**
The type of replay system to be used.

Fixed - Replay value is set and does not change during game play.
Auto% - Replay starting value is set but changes every 50 games to comply with the percentage of replays desired.

- A.1 06 Replay Percent***
The percentage of replays the players are able to earn when Auto Replay is used.
Range: 5% to 50%.

- A.1 07 Replay Start***
Replay start value when Auto% Replay is used.
Range: 15,000,000 to 250,000,000.

*For Auto% Replay.

- A.1 08 Replay Levels***
 The number of replay levels used by the Auto% Replay mode. The range of this setting is 1 to 4. When two replay levels are chosen, the second replay level is automatically adjusted to twice the starting replay level. When three or four replay levels are chosen, their values are automatically adjusted to three or four times the starting replay level.
- A.1 09 Replay Level 1****
A.1 10 Replay Level 2**
A.1 11 Replay Level 3**
A.1 12 Replay Level 4**
 The value to be used for the 1st through 4th Fixed Replay.
 Range: 00 to 250,000,000.
- A.1 13 Replay Boost**
 The replay score can be temporarily boosted by the selected amount EACH time the player reaches or exceeds the replay score. This temporary boost is cancelled when credits equal 0, the player inserts another coin, or when Begin Test is pressed.
- ON - Score is boosted between 500,000 and 5,000,000 points.
 OFF - Replay score is not boosted.
- A.1 14 Replay Award**
 The form of award automatically provided when the player exceeds any replay level for either Auto% Replay or Fixed Replay.
- Credit - Reaching each Replay level awards credit.
 Ticket - Reaching each Replay level awards a ticket.
 Ball - Reaching each Replay level awards an Extra Ball.
 Audit - Reaching each Replay level awards nothing to the player; it does increase the entry value of the Audit Item(s) maintaining a tally of these awards.
- A.1 15 Special Award**
 The award automatically provided when the player scores a special.
- Credit - Scoring a Special awards a Credit.
 Ticket - Scoring a Special awards a Ticket.
 Ball - Scoring a Special awards an Extra Ball.
 Points - Scoring a Special awards 1 Million points.
- A.1 16 Match Award**
 The award automatically provided when the players wins a match.
- Credit - Winning a Match awards a Credit.
 Ticket - Winning a Match awards a Ticket.
- A.1 17 Extra Ball Ticket**
 A Ticket is awarded when the player earns an Extra Ball.
- YES - The player is awarded a Ticket in addition to an Extra Ball.
 NO - The player is not awarded a Ticket

*For Auto% Replay; ** For Fixed Replay

- A.1 18 Maximum Ticket/Player**
The amount of Tickets each player can earn.
Range: 00 to 100.
- A.1 19 Match Feature**
The desired percentage for the Match Feature occurring at the end of the game.
- OFF - Match Feature is not available.
1 - 50% - 1% is 'hard'; 50% is 'extremely easy'. The Match Feature selects a random two-digit number at the end of the game and compares each players score for an identical two digits in the rightmost two positions. A match of these two digit results in an award of a Credit or a Ticket.
- A.1 20 Custom Message**
The message displayed during the Attract Mode.
- YES - A message is displayed
NO - A message is not displayed.
- A.1 21 Language**
The language the game uses: English, French, or German.
- A.1 22 Clock Style**
The style of clock the game uses: A.M./P.M. or 24 Hours.
- A.1 23 Date Style**
The style of date the game uses: Month/Date/Year, or Date/Month/Year.
- A.1 24 Show Date and Time**
The date and time show in the Attract Mode.
- YES - Show the date, time in status report or in the Attract Mode.
NO - Do Not show date, time in status report or in the Attract Mode.
- A.1 25 Allow Dim Illumination**
The game program dims the General Illumination for special effects and during the Attract Mode.
- YES - Dim the General Illumination during the Attract Mode.
NO - Do Not dim the General Illumination.
- A.1 26 Tournament Play**
Equalize Multiball and Jackpots during multi-player games, (do not carry over to next player).
- YES - Keep Multball and Jackpots equal.
NO - Do Not Keep Multiball and Jackpots equal.

- A.1 27 Euro. Scr. Format**
Use either commas or dots between digits when numbers are displayed.
- YES - Dots instead of commas, (example- 1.000.000).
NO - Commas instead of dots, (example- 1, 000, 000).
- A.1 28 Minimum Volume Override**
The volume can be turned Off.
- YES - Volume can be turned Off.
NO - Volume can be turned Down but not Off.
- A.1 29 General Illumination Power Saver**
This allows the general illumination and controlled lamps to be dimmed following a time interval after a game is played. Power Saver Level (A.1 30) determines dimness of the lamps. Using this feature substantially increases the life of the lamps.
Setting: OFF, 2 to 60 minutes.
- A.1 30 Power Saver Level**
When General Illumination Power Saver (A.1 29) is set to On, this controls the intensity of the G.I. and controlled lamps once the game has been idle for a specified period of time.
Range: 4 to 7. (4 = dimmest, 7 = brightest)
- A.1 31 Ticket Expansion Board**
When a Ticket Expansion Board is connected, full control of the ticket dispenser is available. This includes a ticket low/error lamp, resume on ticket jam switch and manual ticket dispense switch.
- YES - Ticket Expansion Board is connected.
NO - Ticket Expansion Board is NOT installed in the game.
- A.1 32 No Bonus Flips**
The activation of flippers during the end of ball "bonus" sequence. Setting to "YES" may extend the life of the flipper mechanisms.
- A.1 33 Game Restart**
When the Start button is pressed during or after the 2nd ball, the game in progress will end and a new game will begin. This adjustment has three settings to determine how this is handled.
- NEVER- Do not allow a new game start until the current game is over.
- SLOW - Restart if the Start button is pressed continuously for over 1/2 second.
This helps to prevent the unintended restart of game in progress.
- INSTANTLY - Restart as soon as the Start button is pressed.
- When the Start button is pressed during game over, or during the 1st ball (to add a player), it is always handled instantly.

A.2 Feature Adjustments

A.2 01 Buy Extra Ball

This determines whether each player may buy one extra ball for one credit at the end of a game.

Settings: 1 Credit
OFF

Factory Default: 1 Credit

A.2 02 Ball Saves

This determines how many times a ball will be saved when it drains. The ball will be saved only once per ball-in-play. The ball saver is available each ball until the adjusted number of ball saves is used by the player.

Settings: OFF
1-5

Factory Default: 1

Example of ball save usage:

With BALL SAVES = 1 (factory default)

BALL 1: Ball save available
Ball drains after ball saver time-out.

BALL 2: Ball save available
Ball drains during ball saver timer, and ball is delivered back onto playfield

BALL 3: Ball save NOT available

A.2 03 Ball Save Time

This sets the number of seconds that the ball saver is activated.

Setting: 5-15

Factory Default: 9

A.2 04 Timed Plunger

This sets a time-out for the ball to be automatically plunged onto the playfield after it has been served.

Settings: OFF
15-90

Factory Default: OFF

- A.2 05 Extra Ball Percent**
 This determines the total percentage of extra balls desired (for all extra balls awarded from all features except replay score levels). The game will adjust the number of COMBOs required for an extra ball to achieve the requested percentage. Set to FIXED to disable the automatic percentaging of the COMBO Extra Ball.
- Setting: FIXED
 15-40%
- Factory Default: 20%
-
- A.2 06 1st Extra Ball Level**
 This is the number of COMBOs that will light the 1st Extra Ball. The machine will start with this value and modify it as necessary to achieve the percentage specified in A.2 05. To use a fixed level for the 1st extra ball, set A.2 05 to FIXED, then set this level.
- Settings: 6-20
- Factory Default: 12
-
- A.2 07 2nd Extra Ball Level**
 This is the number of COMBOs that will light the 2nd Extra Ball.
- Setting: OFF
 35-70
- Factory Default: 50
-
- A2 08 COMBO Extra Ball Memory**
 This determines whether the Extra Ball that is lit from COMBOs stays in memory from ball to ball.
- Settings: YES
 NO
- Factory Default: YES
-
- A.2 09 Bonus X Extra Ball Memory**
 This determines whether the Extra Ball that is lit from the Bonus X rollovers stays in memory from ball to ball.
- Setting: YES
 NO
- Factory Default: YES

A.2 10

Computer Extra Ball Memory

This determines whether the Extra Ball that is lit from the COMPUTER stays in memory from ball to ball.

Settings: YES
NO

Factory Default: YES

A.2 11

Claw Difficulty

This determines the difficulty of enabling the claw for access. Both the claw and the Access Claw lamp are affected by this setting.

Settings: EXTRA EASY
EASY
MEDIUM
HARD
EXTRA HARD

Factory Default: EASY

		Ball Start	Game Start	Memory?
EX. Easy	claw:	open		
	lamp:			
Easy	claw:		open	
	lamp:	lit		
Medium	claw:		closed	yes
	lamp:	lit		
Hard	claw:	closed	closed	no
	lamp:	lit		
Ex. Hard	claw:	closed	closed	no
	lamp:		lit	

A.2 12

Quick Freeze Difficulty

This determines the difficulty of the Quick Freeze feature. This affects the Light Quick Freeze lamp.

Settings: Easy: memory, stays on when used
Medium: memory, goes out when used
Hard: no memory, goes out when used
Ex. Hard: no memory, goes out when Quick Freeze lit

A.2 13

COMBOs for Computer

This determines the number of the COMBOs required to light the COMPUTER. The COMPUTER lights for an award each time this many COMBO shots are completed.

Settings: 6-15

Factory Default: 10

- A.2 14 Computer Memory**
This determines whether the COMPUTER stays lit from ball to ball.
- Settings: YES
NO
- Factory Default: YES
- A.2 15 A-Mode Sound**
Flipper buttons and triggers make a sound in attract mode.
- Settings: YES
NO
- Factory Default: YES
- A.2 16 A-Mode Music**
Music is played periodically in attract mode.
- Setting: YES
NO
- Factory Default: NO
- A.2 17 Demolition Time Champ Credits**
This is the number of credits given to the Demolition Time Champion. The champion is the player who scores the most points during the Demolition Time feature.
- Setting: 0-3
- Factory Default: 1
- A.2 18 Flipper Plunger**
When this adjustment is set to YES, the right flipper will cause the ball to be launched onto the playfield. This adjustment is provided for use when the launch button is broken and/or intermittent. The game will automatically detect a broken launch button, but it may take several games for it to perform the detection. In this case, set FLIPPER PLUNGER to YES until the launch button can be repaired.
- Settings: YES
NO
- Factory Default: NO
- A.2 19 Claw Disabled**
When this adjustment is turned ON, the claw feature won't be enabled for game play. The diverter leading to the claw is left closed. This adjustment is provided for use when the claw is broken. This allows the game to continue playing until the problem is fixed.
- Settings: YES
NO
- Factory Default: NO

A. 3 Pricing Adjustments

- A.3 01 Game Pricing (If set to custom, then 02 to 09 are available)**
The cost of a game is selected from the Standard Pricing Table or by installing Custom pricing.
- A.3 02 Left Coin Units**
A.3 03 Center Coin Units
A.3 04 Right Coin Units
A.3 05 4th Slot Units
The number of coin units purchased by a coin passing through the left, center, right, or fourth coin chute.
- A.3 06 Units/Credits**
Defines the number of coin units required to obtain 1 credit. A coin unit counter in the game program totals the number of coin units purchased through all coin chutes prior to each game. If the total number of these coin units exceeds or matches the Unit per Credit value by a multiple (or more, coin units) of the specified Units per Credit value the Credits display shows the proper number of credits. The coin unit counter retains any remaining coin units, until the start of Ball 2; then the coin unit counter is cleared (its contents are zeroed).
- A.3 07 Units/Bonus**
Additional credits are to be indicated in the credits display, when a certain number of coin units are accumulated.
- A.3 08 Bonus Credits**
The number of credits that are awarded when the Units/Bonus level is achieved.
- A.3 09 Minimum Units**
No credits are to be posted (indicated in the credit display), until the credits unit counter reaches a particular value, by setting this value to 02 (or more).
- A.3 10 Coin Door Type (If set to custom, then 11 to 15 and 20 are available)**
This adjustment is used to pre-set adjustments 11 to 15 based on standard coin doors (U.S.A., German, etc.).
- A.3 11 Collection Text**
The coin system is used to display the Earning Audits.
- A.3 12 Left Slot Value**
A.3 13 Center Slot Value
A.3 14 Right Slot Value
A.3 15 4th Slot Value
The monetary value of the left, center, right, or fourth coin chute.
- A.3 16 Maximum Credits**
The maximum number of credits the game can accumulate, either through game play awards or coin purchases. The range of this setting is 5 through 99. Reaching the specified setting prevents the award of any credits. Factory default is 10.

A.3 17

Free Play

A player can operate the game without a coin (free play) or with a coin.

- NO - A coin is necessary for game play.
- YES - Game play is free; no coin required.

A.3 18

Hide Coin Audits

The coin audits may, or may not, be displayed.

- YES - The coin audits are not displayed.
- NO - The coin audits are displayed.
- HIDE NAMES - The coin audit value is shown but not the audit name.

A.3 20

Base Coin Size

This number is used for ticket per coin calculations.

A.3 21

Coin Meter Units

It is possible to connect a coin meter to the knocker coil driver which will log all coins through all slots. This adjustment activates the use of the knocker driver for this purpose, and determines the value of each unit on the meter. For example, to show the total amount of money collected as "total quarters", set this adjustment to "0.25". To show the amount of money collected as "total dollars", set this adjustment to "1.00".

Setting this adjustment to anything other than Off establishes the coin unit for a meter attached to the knocker driver, and overrides use of the knocker during awards.

A.3 22

Dollar Bill Slot

The system normally requires 150 microseconds between coin pulses. This is too long a delay for a fast-pulsing dollar bill validator. This adjustment may be used to tell the game that there is a fast-pulsing dollar bill validator connected to one of the coin switches.

- NONE = No validator connected.
- LEFT = Validator connected to left slot.
- CENTER = Validator connected to center slot.
- RIGHT = Validator connected to right slot
- FOURTH = Validator connected to fourth.

A.3 23

Minimum Coin Microseconds

This is the minimum width required for coin pulses to be accepted as valid coins. This may be changed to prevent certain kinds of cheating.

Pricing Table

Country	Coin Chutes				Games/Coins	Display	Pricing Adjustments A3											
	Left	Center	Right	4th Chute			02	03	04	05	06	07	08	09				
USA	25¢	\$1.00*	25¢	\$1.00	1/50¢, 2/75¢, 3/\$1 ²	50¢, 75¢, \$1.00												
	25¢	\$1.00*	25¢	\$1.00	1/3x25¢ ²	USA 1/\$0.75												
	25¢	\$1.00*	25¢	\$1.00	1/50¢, 2/\$1 ²	USA 2/\$1.00												
	25¢	\$1.00	25¢	\$1.00	1/50¢, 3/\$1.00 ²	USA 3/\$1.00												
	25¢	\$1.00*	25¢	\$1.00	1/2x25¢, 2/4x25¢, 3/\$1 ²	3/\$1.00 Coin												
	25¢	\$1.00*	25¢	\$1.00	1/2x25¢, 2/\$1.00, 3/\$1.50, 6/\$2.00 ²	USA 6/\$2.00												
	25¢	\$1.00*	25¢	\$1.00	1/2x25¢, 2/\$1.00, 3/\$1.50, 5/\$2.00 ^{2,1}	USA 5/\$2.00												
	25¢	\$1.00*	25¢	\$1.00	1/3x25¢, 1/\$1.50, 4/\$2.00 ²	1/.75, 4/\$2.00												
	25¢	\$1.00*	25¢	\$1.00	1/2x25¢, 2/\$1.00, 4/\$1.50, 6/\$2.00 ²	6/\$2.00 4/\$1.50												
	25¢	25¢	25¢	-	1/4x25¢, 6/\$5.00	1/1, 6/5												
25¢	25¢	25¢	-	1/4x25¢	1/\$1.00													
Canada	25¢	-	\$1.00	-	1/50¢, 2/75¢, 3/\$1 1/50¢, 2/\$1 ²	CANADA 1 CANADA 2												
Austria	5sch 5sch	10sch -	10sch 10sch	- -	1/2x5sch, 3/2x10sch ² 2/5sch, 5/10sch	AUSTRIA CUSTOM												
Australia	20¢ 20¢	\$1 \$1	\$1 \$1	\$2 \$2	1/\$1, 3/\$2 ² 1/\$1, 2/\$2	AUSTRALIA 1 AUSTRALIA 2												
U.K.	£1.00	50P	20P	10P	1/3x10P, 2/50P, 4/£1 ²	U. KINGDOM												
Switzerland	1Fr	2Fr	5Fr	-	1/1Fr, 3/2Fr, 7/5Fr ²	SWISS 1												
	1Fr	2Fr	5Fr	-	1/2Fr, 2/3Fr, 3/4Fr, 5/5F	SWISS 2												
Belgium	5Fr	20Fr	50Fr	-	1/4x5Fr, 1/20Fr, 3/50Fr ²	BELGIUM												
Germany	1DM	2DM	5DM	-	1/2DM, 2/3DM, 3/4DM, 5/5DM ^{1,2}	GER. 1/2DM												
Holland	1G	-	1G	-	1/1G ²	HOLLAND												
Sweden	1Kr	5Kr	10Kr	1Kr	1/10x1Kr, 1/2/5Kr, 1/10Kr, 2/15Kr, 3/20Kr ^{1,2}	SWEDEN 1 SWEDEN 2												
	1Kr	5kr	10Kr	1Kr	1/5x1Kr, 1/5kr, 2/10Kr ²													
France	1Fr	5Fr	10Fr	20Fr	1/3x1Fr, 2/5Fr, 5/10Fr, 10/20Fr ^{2,3}	TARIF 1												
	1Fr	5Fr	10Fr	20Fr	1/2x1Fr, 3/5Fr, 7/10Fr, 14/20Fr ^{2,3}	TARIF 2												
	1Fr	5Fr	10Fr	20Fr	1/5Fr, 3/10Fr, 7/2x10Fr, 7/20Fr ^{1,2,3}	TARIF 3												
	1Fr	5Fr	10Fr	20Fr	2/5Fr, 4/10Fr, 9/2x10Fr, 9/20Fr ^{2,3}	TARIF 4												
	1Fr	5Fr	10Fr	20Fr	2/5Fr, 5/10Fr, 11/2x10Fr, 11/20Fr ^{2,3}	TARIF 5												
	1Fr	5Fr	10Fr	20Fr	1/5Fr, 3/10Fr, 6/20Fr ^{2,3}	TARIF 6												
Italy	500L	500L	500L	-	1/500L ²	ITALY 1												
	500L	500L	500L	-	1/2x500L, 3/4x500L ^{1,2}	ITALY 2												
	500L	500L	500L	-	1/500L, 2/1000L	ITALY 3												
Spain	100P	-	500P	-	1/100P, 6/500P ²	SPAIN												
	25P	-	100P	-	1/25P, 5/100P	CUSTOM												
	25P	-	100P	-	1/25P, 4/100P	CUSTOM												
	25P	-	100P	-	1/2x25P, 2/100P	CUSTOM												
	25P	-	100P	-	1/2x25P, 3/100P	CUSTOM												
Japan	100¥	-	100¥	-	1/100¥ ²	JAPAN												
Chile	Token	-	Token	-	1/1Token ²	CHILE												
Denmark	1Kr	5Kr	10Kr	-	1/3x1 Kr, 3/5 Kr, 7/10 Kr ²	DENMARK												
Finland	1Mka	-	5Mka	-	1/2x1Mka, 3/5Mka ²	FINLAND 1												
	1Mka	-	5Mka	-	1/3x1Mka, 2/5Mka ²	FINLAND 2												
New Zealand	\$1.00 \$2.00	- -	\$2.00 \$1.00	- -	1/\$1, 3/\$2 1/\$1, 3/\$2, (\$2-\$1 door)	NEW ZEALAND 1 NEW ZEALAND 2												
Norway	5Kr	-	10Kr	-	1/5Kr, 2/10Kr, 5/20Kr ²	NORWAY												
Argentina	10¢	10¢	10¢	-	1/1 Token ²	ARGENTINA												
Greece	10D	20D	50D	-	1/2x10D, 1/20D, 3/50D	GREECE												
Antilles	25¢	25¢	1G	-	1/25¢, 4/1G	ANTILLES												
Netherlands	1Hfl	2.5Hfl	2.5Hfl	-	1/1Hfl, 3/2.5Hfl	NETHERLANDS												
Hungary	10F	10F	20F	-	1/1x20F, 1/2x10F, 3/2x20F ²	HUNGARY												

Note: 1. Factory Default. 2. Standard Setting - Change by pressing Enter button. 3. Other functions are also affected.
* Only if Bill Acceptor and Center Coin Chute are available.

A.4 H.S.T.D. Adjustments

A.4 01 Highest Scores

The game maintains a record of the four highest scores achieved to date.

OFF - No high scores are recorded, or displayed.

ON - The four highest scores are stored in memory and displayed in the Attract Mode.

A.4 02 H.S.T.D. Award

The award given for achieving the High Score To Date, or the Champion H.S.T.D.: Credit or a Ticket.

A.4 03 Champion H.S.T.D.

The "Highest" High Score can be displayed in the Attract Mode. This score is not cleared when "High Score Reset Every" occurs.

ON - The "Highest" High Score is retained in memory and displayed.

OFF - The "Highest" High Score is not retained.

A.4 04 Champion Credits

The number of credits or tickets awarded for a Grand Champion Score.
Range: 00 to 10.

A.4 05 H.S.T.D. 1 Credits

A.4 06 H.S.T.D. 2 Credits

A.4 07 H.S.T.D. 3 Credits

A.4 08 H.S.T.D. 4 Credits

The number of credits or tickets awarded whenever a player exceeds the 1st, 2nd, 3rd, or 4th highest score.

Range: 00 to 10.

A.4 09 High Score Reset Every

The number of games to be played before an automatic reset of the displayed "Highest Score" occurs. The values provided upon reset are those selected by the operator in the Back-up High Scores.

Range: OFF (disabled); 250 to 20,000.

A.4 10 Backup Champion

The Back-up Grand Champion Score.

Range: 00 to 999,000,000.

A.4 11 Backup H.S.T.D. 1

A.4 12 Backup H.S.T.D. 2

A.4 13 Backup H.S.T.D. 3

A.4 14 Backup H.S.T.D. 4

The first through the fourth Back-up High Score values. The game automatically restores this value when the High Score Reset Every value is reached.

Range: 00 - 999,000,000.

A.5 Printer Adjustments (optional board required)

A.5 01 Column Width
The column width to be printed.
Range: 22 to 80.

A.5 02 Lines Per Page
The amount of lines per page.
Range: 20 to 80.

A.5 03 Pause Every Page
Choose whether the printer pauses at the end of a page.

YES - The printer does pause.
NO - The printer doesn't pause.

A.5 04 Printer Type
Select the type of printer: Parallel, Serial, ADP, Mini-Drucker, or NSM.

A.5 05 Serial Baud Rate
Select which baud rate to use for serial or ADP communications (bit rate): 300, 600, 1200, 2400, 4800, or 9600.

A.5 06 Serial D.T.R. (Data Terminal Ready)
When a serial printer is used, this line may be connected to a printer output line signaling that the printer is busy.

NORMAL -Normal D.T.R. signal goes low to indicate the printer is not ready.

INVERTED - Inverted D.T.R. (busy) signal goes high to indicate the printer is not ready.

IGNORE -D.T.R. signal is ignored.

ERROR MESSAGES

The WPC game program has the capability to aid the operator and service personnel. At game turn-on, or after pressing the Begin Test switch, once the game has been operating for an extended period, the display may signal with a message, "Press ENTER for Test Report". This indicates the game program has detected a possible problem with the game.

To obtain details of the problem open the coin door and press the Begin Test switch. Press the Enter button to begin displaying the message(s). The following messages apply to your game.

Check Switch ##.

This message indicates that at least one switch was stuck 'On' at game turn-on or has NOT been actuated during ball play (for 90 balls or ≈30 games). The game program compensates the game play requirements affected by each disabled switch to allow 'nearly normal' play. This helps keep your game earning, until the service technician can repair the problem.

To verify the problem, refer to the Test Menu text describing Switch Testing, and check each reported switch using applicable switch tests. Always check switch operation using a ball, to simulate game conditions. Switch problems may often be resolved by adjusting the wire switch actuators, fixing switch circuitry problems, securing loose connectors, etc. Mechanisms using 'opto switches' (drop targets, etc.) need to be checked for proper power connections (+12V dc and ground).

Pinball Missing.

This game normally uses six balls, however, it will operate with less. This message announces that a ball is missing or stuck. When the ball is located, return it to the game via the Outhole. Other possibilities for this problem could be malfunctions of the Ball Trough switches or the Ball Shooter switch.

xxxxx Sw. Is Stuck On.

This message indicates that a switch, which is not usually On, remains in the On position after the game is switched On. The stuck switch is essential for game play (for example, a coin chute switch, the slam tilt switch, the plumb bob tilt switch), and should be cleared to permit proper game operation.

Ground Short Row-N, Wht-xxx.

This message indicates that the switch wires being called out are touching a grounded part on the playfield or coin door. The following should be checked:

1. Slam tilt (or other coin door switch) touching the grounded coin door.
2. A leaf-type, playfield switch touching a grounded part.
3. Players poking metallic objects (wires, coat hangers, etc.) into the game.
4. Switch cable insulation pierced or damaged allowing bare wire contact with a grounded part.
5. All switches in a row closing at the same time. **Note:** This is NOT a switch problem; however, for most games it is a very rare possibility.

U6 Checksum Error.

The game ROM checksum is invalid. If this occurs replace the game ROM.

Time and Date Not Set.

The real time clock is not running. Go to U.4 of the Utilities Menu and set the time and date.

Factory Settings Restored.

This message indicates that the CMOS RAM (U8) no longer retains any custom Pricing or Game Adjustment settings and has reverted to factory default settings. Generally, the following CPU checks will isolate the cause of the CMOS RAM memory failure. The voltages at pin 28 and pin 26 of U8 should be +5V (game turned On) and at least +4V (game turned Off). When the voltage drops below +4V, memory reset occurs. Check the batteries and battery holder. Be sure that the batteries are good and that there is no contamination on the battery holder terminals. Turn the game OFF, and use an ohmmeter to check diodes D1 and D2 on the CPU Board. D1 should read 0 ohms when forward-biased and infinite ohms when reverse-biased. D2 should read 15 ohms when forward-biased and infinite ohms when reverse-biased. (Readings taken with an analog meter.) This message can also indicate that there is an open diode on a 50V coil and noise is entering the circuit.

Opto Theory

The opto receiver (Photo Transistor) should be approximately 0.1 - 0.7 volts when the opto beam is unblocked and approximately 11 - 13 volts when the opto beam is blocked. The opto transmitter (LED) should always be approximately 1.4 volts. **Note:** The transmitter (LED) is larger than the receiver (Photo Transistor); it protrudes further from its case.

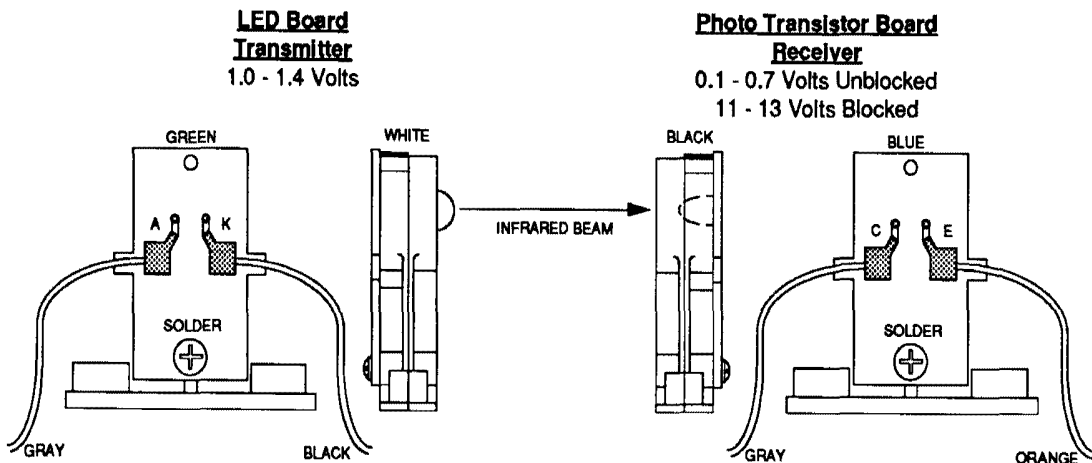

CPU L.E.D.'s

The CPU has three L.E.D.s located on the upper left side of the board D19, D20, and D21. On game power-up D19 and D21 turn on for a moment then, D19 turns off and D20 starts to blink rapidly. D21 remains on. The system has detected a problem if the following happens:

CPU Board L.E.D. Error Codes

- Center L.E.D. blinks one time - U6 ROM Failure
- Center L.E.D. blinks two times - U8 RAM Failure
- Center L.E.D. blinks three times - U9 Custom Chip Failure

Sound Board Beep Error Codes
Upon Game Turn-On:

- 1 Beep = Sound Board O.K.
- 2 Beeps = U2 Failure
- 3 Beeps = U3 Failure
- 4 Beeps = U4 Failure
- 5 Beeps = U5 Failure
- 6 Beeps = U6 Failure
- 7 Beeps = U7 Failure
- 8 Beeps = U8 Failure
- 9 Beeps = U9 Failure

Cryoclaw/Elevator

THEORY OF OPERATION

The Cryoclaw/Elevator mechanism consists of two gear-reduced motors controlled by the game CPU. Several opto switches are used to detect the positioning of the motors. Attached to the claw is an electromagnet, which is used to pick up the pinball during game play.

Elevator:

The elevator motor runs in only one direction. The CPU pulses the motor control input, rather than turning it on solid, in order to slow its speed. The elevator has a single opto (index) switch for detecting the DOWN position of the elevator. Due to the inertia of the motor, it is normal for the elevator motor to be stopped with the switch activator just beyond the index switch.

Claw:

The claw motor runs in both directions. The CPU pulses the motor control inputs to vary the speed of the claw arm. The claw has two opto switches for detecting the position of the claw arm. The switch states for the arm positions are:

Claw Right Switch	Claw Left Switch	
OFF (blocked)	OFF (blocked)	arm out of range
OFF (blocked)	ON (open)	arm at right (above the elevator)
ON (open)	OFF (blocked)	arm at left (away from elevator)
ON (open)	ON (open)	arm within range of motion

When both position switches are OFF (blocked) the CPU cannot determine the position of the arm. In this case, the CPU will not turn on the claw motor, since it does not know whether to move the arm to the left or the right. To reposition the arm when it is out of range, use the CLAW TEST. Do not attempt to move the claw by hand.

Note that if the position switches are disconnected, the CPU will think that the claw arm is out of range.

During game play, the Cryoclaw/Elevator is operated both automatically, and under player control. During multiball play, the claw is always operated automatically. The claw is also operated automatically during ball search.

The CPU monitors the operation of the Cryoclaw/Elevator to detect malfunctions. When the CPU has detected a malfunction, it will not open the diverter on the right ramp leading to the Cryoclaw/Elevator. The Cryoclaw/Elevator can also be disabled by option setting, in case of an intermittent error.

ERROR MESSAGES

The game test report will display an error message when the CPU has detected a malfunction of the Cryoclaw/Elevator. These error messages are explained below.

Claw Disabled

This message is displayed when the Cryoclaw/Elevator is disabled by option adjustment.

Arm Out of Range

This message is displayed when the claw arm is positioned out of range. This message can also be caused by one or more broken claw position opto switches.

Elevator Broken

This message is displayed when the CPU cannot detect an activation of the elevator index opto switch. This can be caused by either a broken switch, or a non-functional elevator motor.

Magnet Broken

This message is displayed when the game is unable to pick up a ball from the elevator platform with the claw magnet. This can be caused by the magnet being non-functional, or by the Elevator Hold switch being broken.

Claw Motor Error

This message is displayed when the CPU is unable to detect movement of the claw arm. This can be caused by a non-functional claw motor, or either of the position optos being broken.

Ramp Diverter Is Stuck Open

This message is displayed when the CPU detects balls going to the Cryoclaw/Elevator when it expects the diverter to be closed, and thus directing balls down the right ramp.

Ramp Diverter Is Stuck Closed

This message is displayed when the CPU detects balls rolling down the right ramp when it expects the diverter to be open, and thus directing balls to the Cryoclaw/Elevator.

LED List

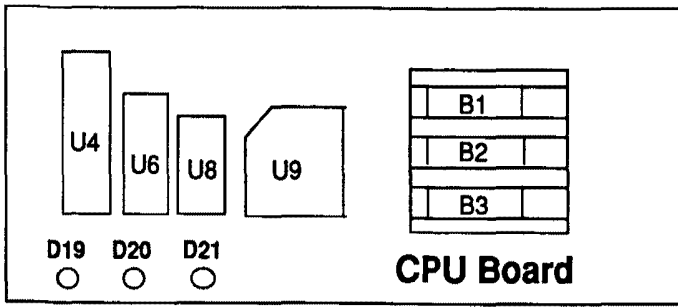

CPU Board

D19 , Blanking
 D20, Diagnostic
 D21, +5vdc

At game Turn-On = D19 & D21 On, D20 Off
 During Normal Operation = D19 Off, D20 Flashing, D21 On

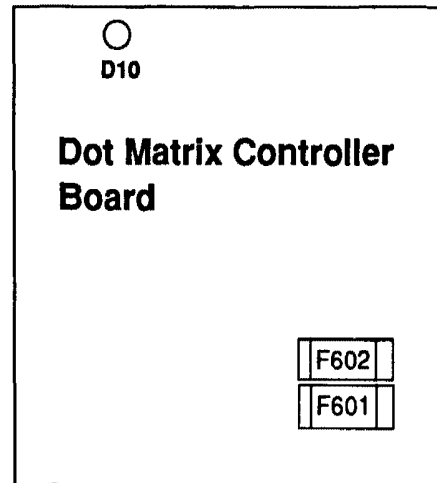

Dot Matrix Controller Board

D10, +5V Circuit, Normally On

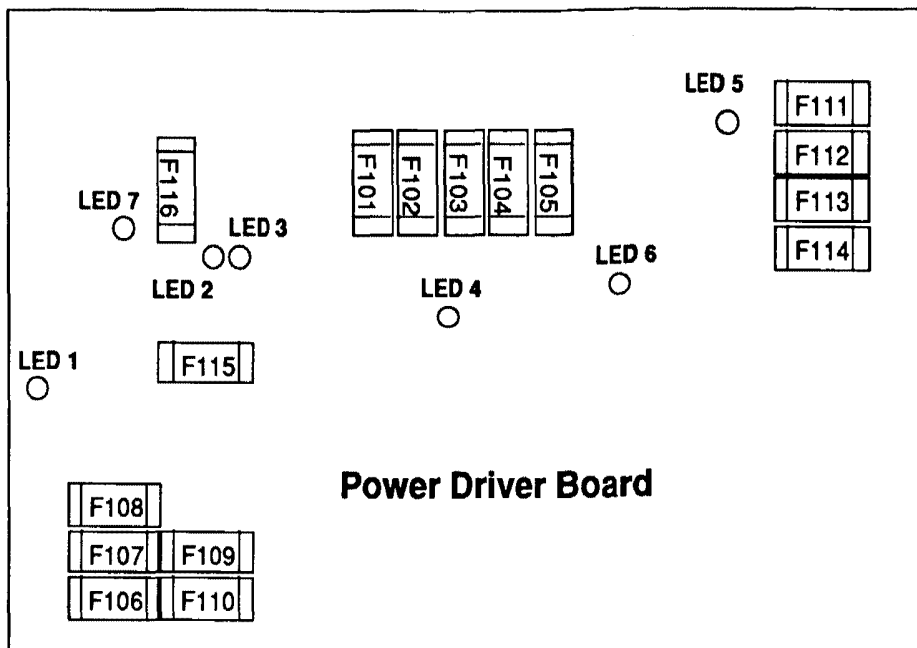

Power Driver Board

LED 1, +12vdc Switch Circuit, Normally On
 LED 2, High/Low Line Voltage Sensor, Normally On
 LED 3, High/Low Line Voltage Sensor, Normally Off
 LED 4, +5vdc, Digital Circuit, Normally On
 LED 5, +20vdc, Flashlamp Circuit, Normally On
 LED 6, +18vdc, Lamps Circuit, Normally On
 LED 7, +12vdc, Power Circuit (motors relays etc.), Normally On

Fuse List

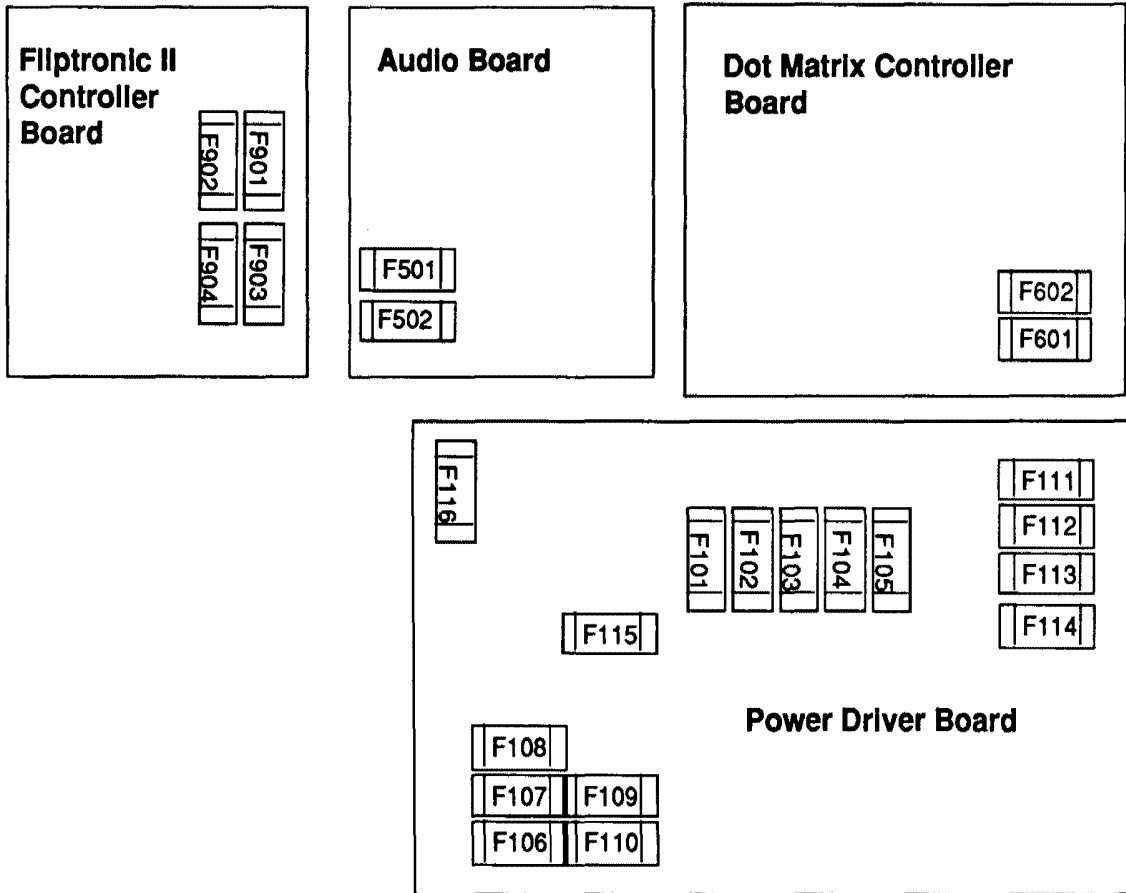

Audio Board

F501 -25V Circuit 3A, S.B.
 F502 +25V Circuit 3A, S.B.

Dot Matrix Controller Board

F601 +62V Circuit, 3/8A, F.B.
 F602 -113V & -125V Circuits 3/8A, F.B.

Power Driver Board

F101 Left Flipper 3A, S.B.
 F102 Right Flipper 3A, S.B.
 F103 Solenoid #25-#28 3A, S.B.
 F104 Solenoid #9-#16 3A, S.B.
 F105 Solenoid #1-#8 3A, S.B.
 F106 G.I. #5 Wht-Vio 5A, S.B.
 F107 G.I. #4 Wht-Grn 5A, S.B.
 F108 G.I. #3 Wht-Yel 5A, S.B.
 F109 G.I. #2 Wht-Org 5A, S.B.
 F110 G.I. #1 Wht-Brn 5A, S.B.
 F111 Flasher Secondary 5A, S.B.
 F112 Solenoid Secondary 7A, S.B.
 F113 +5V Logic 5A, S.B.
 F114 +18V Lamp Matrix 8A, N.B.
 F115 +12V Switch Matrix 3/4A, S.B.
 F116 +12V Secondary 3A, S.B.

Fliptronic II Controller Board

F901 Upper Right Flipper 3A, S.B.
 F902 Upper Left Flipper 3A, S.B.
 F903 Lower Right Flipper 3A, S.B.
 F904 Lower Left Flipper 3A, S.B.

Line Filter

Domestic Game 8A, N.B.
 Foreign Game 5A, S.B.

MAINTENANCE INFORMATION

LUBRICATION

The two main lubrication points of the Ball Release mechanism are the pivots for the arm. The mechanisms of other playfield devices are somewhat similar to the Ball Release device, and have the same lubrication requirements. A medium viscosity oil (switch target grease) is satisfactory for these devices.

Because of the functional design (arm-actuated via solenoid plunger operation), the pivot points of the Left and Right Kickers ("Slingshots") all require lubrication as a regular servicing procedure.

Lubrication to ensure proper operation also applies to the target blades of the Drop Targets. MBI Instrument Grease, also known as Drop Target Switch Lubricant, with a Williams' part number of E1165, is a recommended lubricant.

SWITCH CONTACTS

Playfield Switches

For proper game operation, switch contacts should be free of dust, dirt, contamination, and corrosion. Blade switch contacts are plated to resist corrosion. Cleaning blade switch contacts requires gentle closing of the contacts on a clean business card or piece of paper, and then pulling the paper about 2 inches, which should restore the clean contact surface. Adjust the switch contacts to a 1/16-inch gap.

Flipper Switches

This game uses the new Fliptronic II Electronic Flipper System. The End-of-Stroke switches are NORMALLY OPEN. The switch should close when the flipper is energized. All E.O.S. switches and flipper button cabinet switches are gold flashed computer grade leaf switches. Only low computer current is carried through these switches. DO NOT FILE or abrasively clean these switches! DO NOT REPLACE these switches with the old style tungsten high current type switches as intermittent operation could occur. **Note:** Unlike the old style of flipper, an E.O.S. switch failure does not harm the flipper. The game notifies the operator of the switch being mis-adjusted in the test report, but continues to play. The E.O.S. switches are a means by which the new electronic flippers feel and play with all of the subtleties of the old flippers.

CLEANING

Good game action and extended playfield life are the results of regular playfield cleaning. During each collection stop, the playfield glass should be removed and thoroughly cleaned and the playfield should be wiped off with a clean, lint-free cloth. The game balls should be cleaned and inspected for any chips, nicks, or pits. Replace any damaged balls to prevent playfield damage.

Regular, more extensive, playfield cleaning is recommended. However, avoid excessive use of water and caustic or abrasive cleaners because they tend to damage the playfield surface. Playfield wax (or any carnauba based wax), or polish may be used sparingly, to prevent a buildup on the playfield surface. Do not use cleaners containing petroleum distillates on any playfield plastics because they may dissolve the plastic material or damage the artwork.

USE NOVUS PLASTIC POLISH TO CLEAN THE EYEBALL.

PLAYFIELD DISASSEMBLY

Removing the Cryoclaw

BE SURE TO LABEL ALL CABLES THAT YOU DISCONNECT. THIS MAKES RE-INSTALLATION MUCH EASIER.

- 1) Turn off and unplug the game. Open the coin door, remove the front molding and the playfield glass. Pull the playfield up and forward so that the hanger brackets rest on the front of the cabinet.
- 2) Remove the two hex head screws that hold the silver plastic cover to the magnet, then lift off the cover. Remove the plastic that covers the claw. It is held in place by two Phillips screws.
- 3) Lift the playfield all the way up. Unplug the motor cable from the D.C. Motor Control board, and the claw magnet cable leading to the Cryoclaw assembly.
- 4) Lower the playfield so that the hanger brackets rest on the front of the cabinet. Unplug the cable from the Cryoclaw opto PC board. The PC board is located in front of the Cryoclaw assembly.
- 5) The four screws that hold the Cryoclaw assembly are located behind the back panel. (The Cryoclaw and the Elevator share two of the screws.) Remove the screws and lift the Cryoclaw assembly up.

Removing the Elevator

BE SURE TO LABEL ALL CABLES THAT YOU DISCONNECT. THIS MAKES RE-INSTALLATION MUCH EASIER.

- 1) Turn off and unplug the game. Open the coin door, remove the front molding and the playfield glass. Lift the playfield all the way up.
- 2) Remove the two hex head screws that hold the bottom of the Elevator assembly. Then, unplug the cable from the Elevator opto PC board, the motor cable from the EMI board and the opto switches cable.
- 3) Lower the playfield so that the hanger brackets rest on the front of the cabinet. Remove one hex head screw located between the diverter ramp and the Elevator assembly.
- 4) Remove the four screws from the back of the Elevator assembly. (The Cryoclaw and the Elevator share two of the screws.) Tip the Elevator assembly forward and lift it off of the back panel.

Removing the Ramps

Switches can be either unsoldered, unscrewed from their bracket or unplugged from under the playfield. BE SURE TO LABEL ALL WIRES THAT YOU DISCONNECT. THIS MAKES RE-INSTALLATION MUCH EASIER.

- 1) Turn off and unplug the game. Open the coin door, remove the front molding and the playfield glass. Pull the playfield up and forward so that the hanger brackets rest on the front of the cabinet.
- 2) Remove wire ramp #1 from the playfield. The ramp is held to two posts by (11/32") ESNA nuts. Unscrew the nuts, then pull the wire ramp out of the metal bracket attached to the diverter ramp.
- 3) Remove the double-wire ramp next. First, remove the transparent plastic above the ramp. Then unscrew the one (11/32") ESNA nut and one hex head screw between the double-wire ramp and wire ramp #3. Pull the wire ramp out of the metal bracket attached to the Cryoclaw ramp. *When re-installing the ramp, be sure to fit the double-wire ramp over wire ramp #3, where these ramps meet.*
- 4) Remove wire ramp #3 from the playfield. Unscrew one (11/32") ESNA nut and one (1/4") hex head screw. The hex head screw is driven directly into the playfield, under a strip of plastic. It may be easier to unscrew the plastic before removing the nut. After removing the nut and screw, carefully, work the ramp leg up through the plastic. Pull the wire ramp out of the bracket on the bottom of the plastic ramp #3.
- 5) Now, remove wire ramp #2 from the playfield. There are two (1/4") ESNA nuts holding the ramp; one nut is attached to a post, the other is attached directly to the playfield under a strip of plastic. It may be easier to unscrew the plastic before removing the nut. After removing the nuts, carefully, pull the leg of the ramp up through the plastic. When the wire ramp is clear of the plastic strip, pull it out of the metal bracket attached to plastic ramp #3.
- 7) Remove plastic ramp #3. Unscrew two (1/4") hex head screws from the ball guide located at the bottom of the ramp. Then remove the two small Phillips head screws on the ramp flap. Disconnect any switches that may be attached to the ramp. Lift the ramp off of the playfield.
- 8) Remove plastic ramp #2. Unscrew two (1/4") hex head nuts from the metal ball guides that are attached to the ramp near where the ramp and the playfield meet. Then remove the two small Phillips head screws from the ramp flap. Disconnect any switches that may be attached to the ramp. Lift the ramp off of the playfield.
- 9) Remove the wire cage from the playfield. Unscrew two (1/4") hex head screws. To remove one of the screws you must slide the plastic piece above it to the side. Pull the wire cage out of the playfield.
- 10) Remove the diverter ramp. Use an Allan wrench to disconnect the diverter shaft and paddle from underneath the playfield. Unscrew two (1/4") hex head screws and one (5/16") ESNA nut. Disconnect any switches attached to the ramp, then lift the ramp off of the playfield.
- 11) Remove the single wire ramp, which is held by one (5/6") ESNA nut. Carefully, pull the ramp out of the metal bracket attached to the Cryoclaw ramp.
- 12) Remove the drain/wireform. The drain/wireform is attached to the playfield with one (1/4") hex head screw. Disconnect the switch before pulling the ramp out of the playfield.

Item	Description
1.	Diverter Ramp Assembly
2.	Plastic Ramp #2
3.	Wire Cage
4.	Cryoclaw Ramp
5.	Opto Car Tunnel Assembly
6.	Double Wire Ramp
7.	Wire Ramp #2
8.	Wire Ramp #3
9.	Wire Ramp #1
10.	Plastic Ramp #3
11.	Inclined Ramp Assembly
12.	Feed Ramp Assembly
13.	Single Wire Ramp
14.	Drain/Wireform

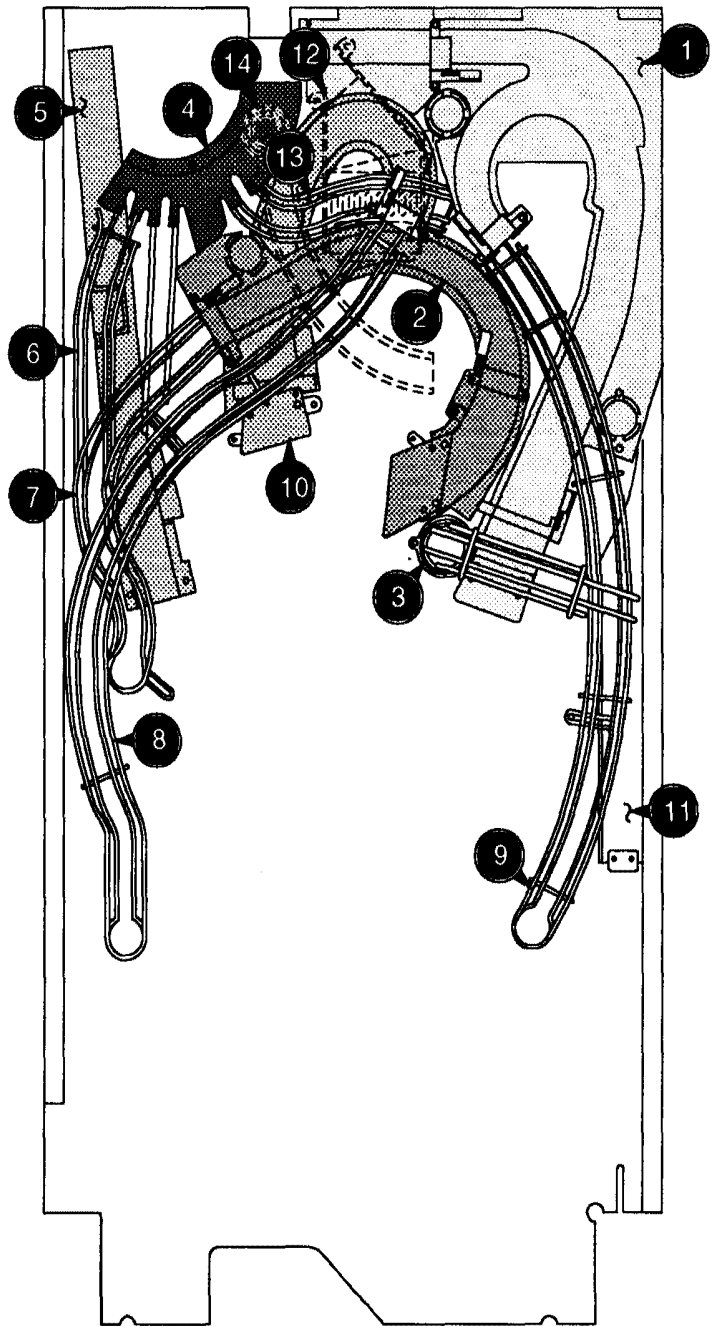

SECTION 2

Parts Information

Backbox Assembly

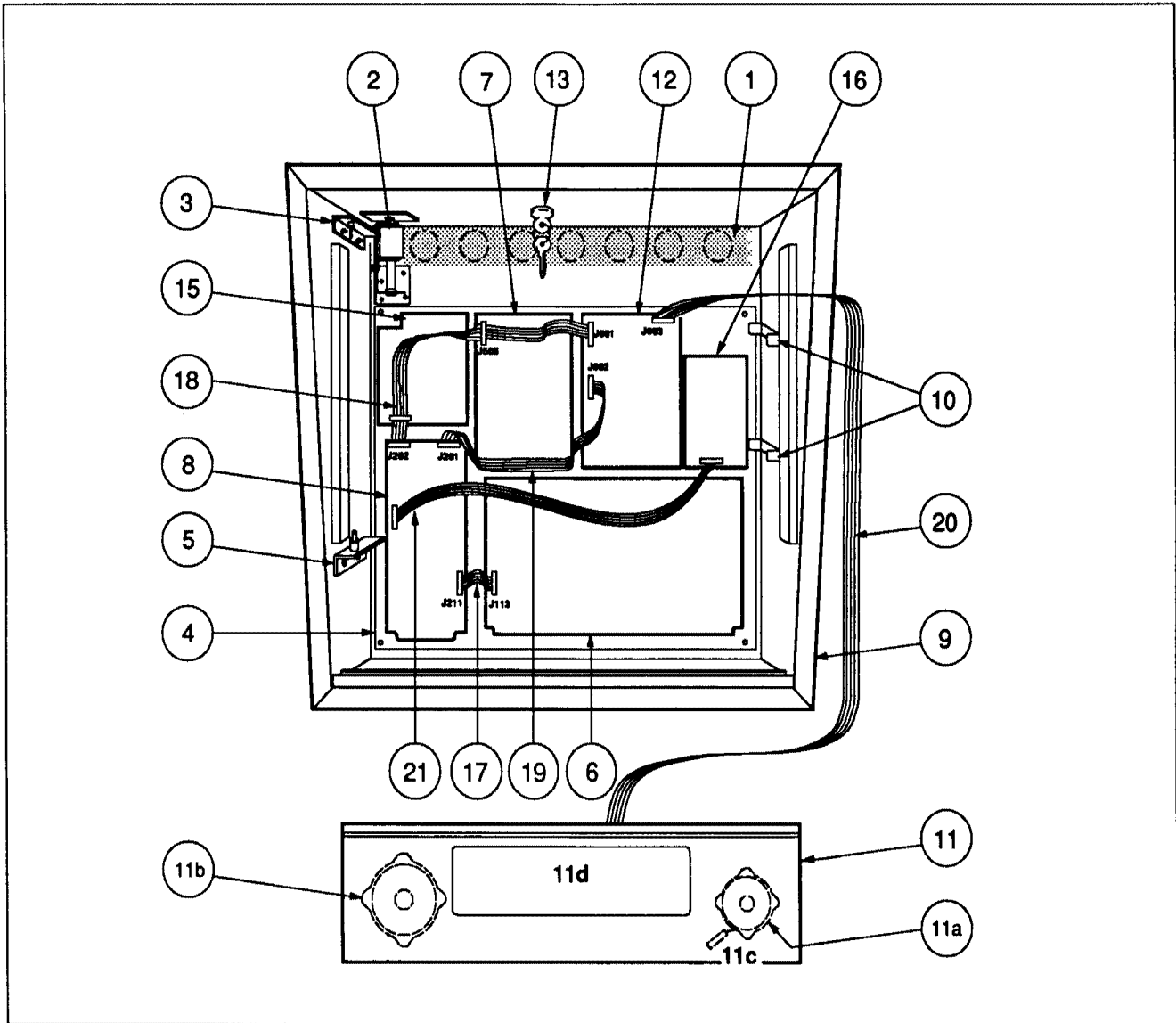

Item	Part Number	Description	Item	Part Number	Description
1.	01-6645	Venting Screen	15.	A-15472-1	Fliptronic II Board
2.	B-10686-1	Knocker & Bracket Assy.	16.	A-16100-2	Aux. Driver PCB Assy.
3.	A-12497	Upper Insert Bd. Hinge Assy.	■ Ribbon Cables:		
4.	A-14092-5	Mounting Plate Assembly	17.	5795-12653-03	Ribbon Cable, 3"
5.	A-12498	Lower Insert Bd Hinge Assy.	18.	5795-13018-01	Ribbon Cable, 23.5"
6.	A-12697-3	Power Driver Assembly	19.	5795-10938-14	Ribbon Cable, 14"
7.	A-16917-50028	WPC Sound Board	20.	5795-12838-30	Ribbon Cable, 30"
8.	A-12742-50028	WPC CPU Board	21.	5795-10938-32	Ribbon Cable, 32"
9.	A-18085	Backbox Assembly	■ Miscellaneous Parts:		
10.	01-9047	Insert Stop Bracket	A-8552-50028	Tempered Backglass Assy.	
11.	A-18038	Speaker / Display Assy.	08-7456	Backbox Glass: 27" x 18-7/8"	
a)	5555-12924-00	Speaker, 4Ω, 15w	31-1357-50028	Screened Translight	
b)	5555-12856-00	Speaker, 5-1/4", 4Ω, 25w	03-8228-2	Glass Channel Top (1)	
c)	5045-12914-00	Cap., 10μfd., 50v, (±20%)	03-8228-3	Glass Channel Edge (2)	
d)	5901-12784-00	Dot Matrix Display/Driver Bd.	03-8229-1	Glass Lift Channel (1)	
12.	A-14039	Dot Matrix Controller Board			
13.	A-13379	Lock & Plate Assembly			
a)	20-9637	Lock & Cam Kit			
14.	50028-IN	Insert Board			

Cabinet Assembly

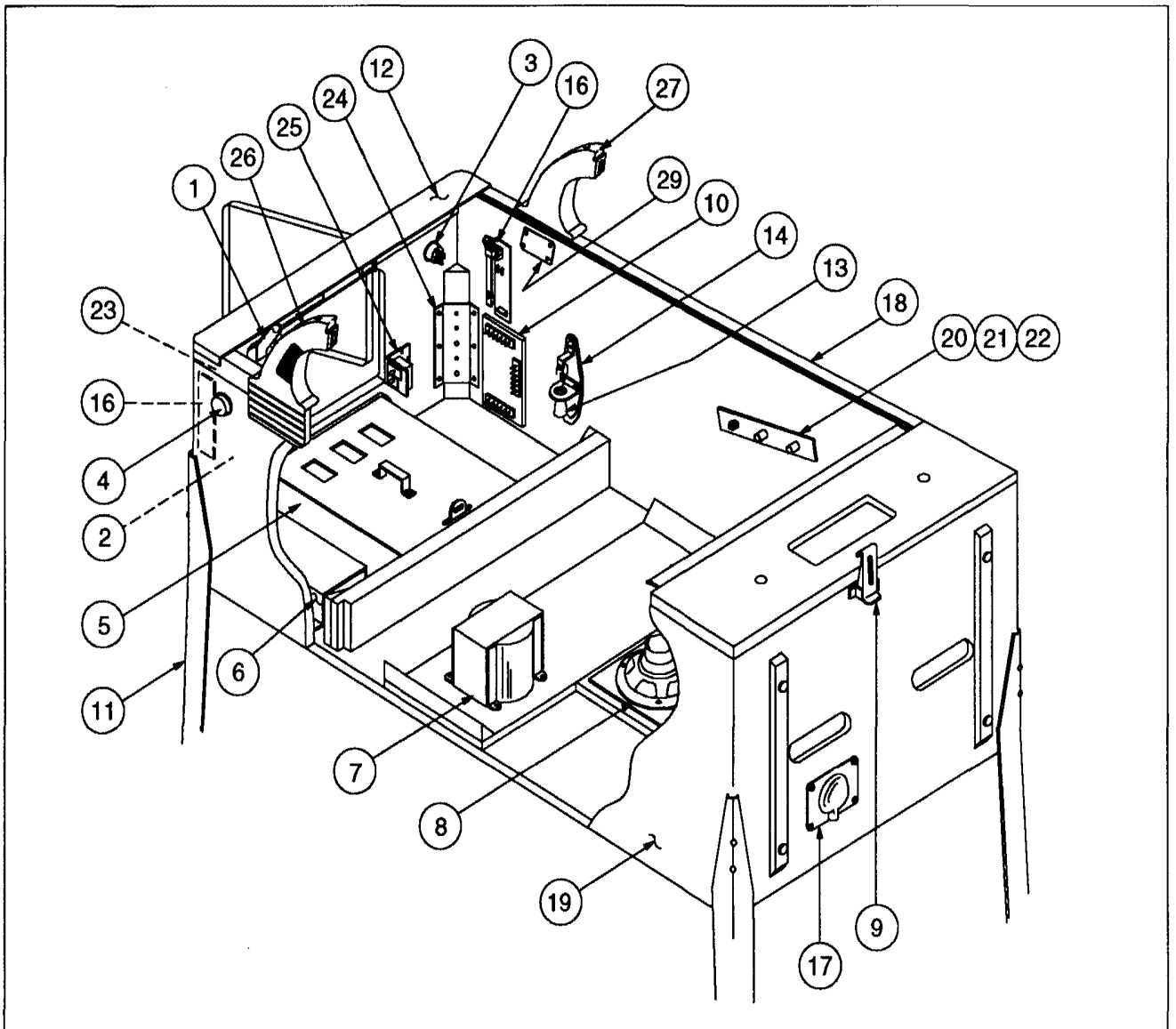

Item Part Number Description

- 1. A-16773 Lever Guide Assembly
- 2. 20-9663-9 Extra Ball Button, Yellow
- 3. 20-9663-1 Start Button, Yellow
- 4. A-16883-4 Flipper Button - Red (2 Used)
- 5. A-17445-1 6-Ball Cashbox Assembly
- 6. * A-17540 Univ. Power Interface Assy.
- 7. 5610-13953-00 WPC Transformer
- 8. 5555-12929-00 Speaker, 4Ω, 6", 25w
- 9. 20-9347 Toggle Latch
- 10. A-17051-1 Coin Door Interface Bd.
- 11. C-10843-2 Metal Leg Assembly
- 12. A-16055 Front Molding Assembly
- 13. 20-6502-A Plum Bob
- 14. A-15361 Tilt Mechanism Assembly
- 15. * Cordset
- 16. A-17316 Opto Flipper Assembly (2 Used)
- 17. 01-10714 Line Cord Cover
- 18. A-12359-3 Side Molding Assy. (2 Used)
- 19. 11-1171 Wood Cabinet
- 20. 01-11408 Spacer (2 Used)
- 21. 02-4329-1 Pivot Nut, 7/8" (4 Used)

* See Application Chart (p.2-4).

Item Part Number Description

- 22. 02-4352 Pivot Bushing (2 Used)
- 23. 20-9663-B-4 Launch Ball, Red
- 24. 01-11400 Leg Plate (4 Used)
- 25. A-17175-1 Cable & Interlock Switch Assy.
- 26. A-18016-1 Control Handle Assy., Right
- 27. A-18016-2 Control Handle Assy., Left
- 28. A-18142-1 Control Handle Plate, Right
- 29. A-18142-2 Control Handle Plate, Left

■ Miscellaneous Parts:

- 08-7028-1 Tempered Playfield Glass, Wide Body: 23.75" x 43"
- 01-10797 Playfield Support Bar, 18" Long
- 01-11791 Service Switch Actuator
- 01-12352 Clip Bracket
- 08-7377 Leg Leveler Adjuster, 3"
- 20-6500 Steel Ball, 1-1/16" (6)
- A-17195 Tilt Switch Assy. w/Cable
- 01-12328-1 Backbox Mounting Brkt., Left
- 01-12328-2 Backbox Mounting Brkt., Right
- 01-12819 Corner Bracket, Right
- 01-12820 Corner Bracket, Left

Universal Power Interface/Cordset Application Chart

COUNTRY	UNIVERSAL PWR INTERFACE ASSY	VOLTAGE PROGRAMMING JUMPER CABLE				5AMP FUSE LABEL		3AMP FUSE LABEL		2.5AMP FUSE LABEL	POWER ADAPTER CORD	CORDSET										
		H-17837-1	H-17837-2	H-17837-3	H-17837-4	5731-09651-00 FUSE LABEL	16-9668 FUSE LABEL	5730-09252-00 FUSE LABEL	16-9670 FUSE LABEL			16-9669	5850-14052-00	5850-13271-00	5850-13272-00	5850-13273-00	5850-13274-00	5850-13275-00	5850-13276-00	5850-13277-00	5850-13278-00	A-17175-2
UNITED STATES	X		X				X	X			X	X										
CANADA	X	X					X	X				X										
TAIWAN	X		X				X	X				X										
MEXICO	X		X				X	X				X										
CENTRAL AMERICA	X		X				X	X				X										
SOUTH KOREA	X		X				X	X				X										
PUERTO RICO	X		X				X	X				X										
AUSTRIA	X			X	X	X			X				X									
BELGIUM	X			X	X	X			X				X									
FINLAND	X			X	X	X			X				X									
FRANCE	X			X	X	X			X				X									
GREECE	X			X	X	X			X				X									
HOLLAND	X			X	X	X			X				X									
HUNGARY	X			X	X	X			X				X									
NETHERLANDS	X			X	X	X			X				X									
NETH. ANTILLES	X			X	X	X			X				X									
NORWAY	X			X	X	X			X				X									
POLAND	X			X	X	X			X				X									
PORTUGAL	X			X	X	X			X				X									
SPAIN	X			X	X	X			X				X									
SWEDEN	X			X	X	X			X				X									
TURKEY	X			X	X	X			X				X									
WEST GERMANY	X			X	X	X			X				X									
UNITED KINGDOM	X			X	X	X			X					X								
IRELAND	X			X	X	X			X				X									
HONG KONG	X			X	X	X			X				X									
DENMARK	X			X	X	X			X					X								
ITALY	X			X	X	X			X						X							
CHILE	X			X	X	X			X							X						
PEOPLE'S REP. OF CHINA	X			X	X	X			X							X						
SWITZERLAND	X			X	X	X			X								X					
AUSTRALIA	X			X	X	X			X											X		
NEW ZEALAND	X			X	X	X			X											X		
ARGENTINA	X			X	X	X			X											X		
JAPAN	X				X		X	X												X	X	

A-16917-50028 Sound Board Assembly

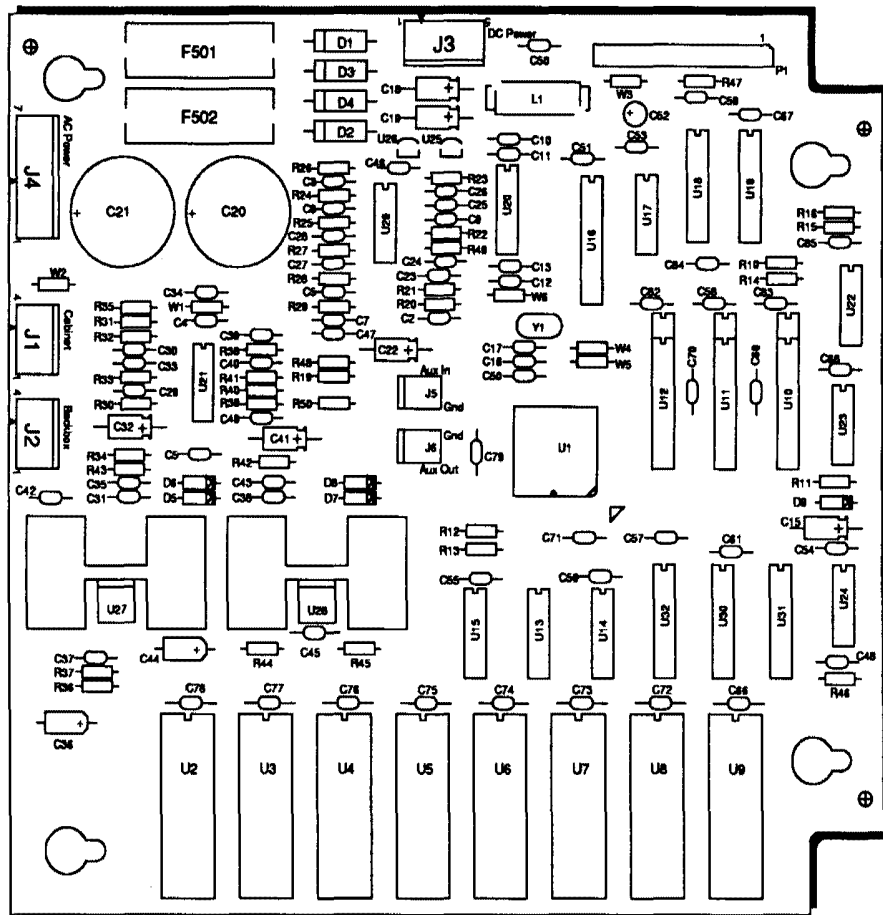

Part No.	Designator	Description	Part No.	Designator	Description
4004-01005-06	U27, U28	Mach. Screw, 4-40 x 3/8"	5250-13302-00	U25	78L05 Pos 5 Volt Reg TO-92
4404-01119-00	U27, U28	Nut, 4-40	5250-13303-00	U26	79L05 Neg 5 Volt Reg TO-92
5010-08772-00	R39, R41	Resistor, 15K Ω , 1/4W, 5%	5283-10551-00	U17	IC74F00 Fast Quad NAND Gate
5010-08774-00	R30, R34, R37, R42, R45	Resistor, 22K Ω , 1/4W, 5%	5311-10946-00	U22	IC74HC74 Dual D Flip Flop
5010-08991-00	R10, R12 -R16	Resistor, 4.7K Ω , 1/4W, 5%	5311-10947-00	U23	IC74HC125 quad Tri-State Buffer
5010-09034-00	R47	Resistor, 10K Ω , 1/4W, 5%	5311-10948-00	U15	IC74HC138 1 of 8 Decoder
5010-09035-00	R11, R19, R33, R40	Resistor, 47K Ω , 1/4W, 5%	5315-12009-00	U18, U19	IC74HC374 Octal D Flip Flop
5010-09036-00	R46	Resistor, 100 Ω , 1/4W, 5%	5311-12043-00	U13, U14	IC74HC174 Hex D Flip Flop
5010-09219-00	R31, R32, R38	Resistor, 8.2K Ω , 1/4W, 5%	5311-12538-00	U24	IC74HC14 Hex Schmitt Inverter
5010-09358-00	R50	Resistor, 1K Ω , 1/4W, 5%	5311-12287-00	U30 - U32	IC74HC541 Octal Bus Driver
5010-09534-00	W4, W6	Resistor, 0 Ω (Jumper)	5340-13304-00	U10 - U12	ICSRAM 2Kx8 35ns .300DIP
5010-13420-00	R36, R44	Resistor, 680 Ω , 1/4w, 5%	5370-12730-00	U21, U29	ICTL084 Quad op Amp
5010-13607-00	R20-R29, R48, R49	Resistor, 6.2K Ω , 1/4w, 5%	5370-13419-00	U27, U28	Audio Power Amp TDA2030AV
5010-13517-00	R35, R43	Resistor, 15 Ω , 1/4w, 5%	5371-13299-00	U20	ICDAC AD-1851 16 bit
5040-09365-00	C15, C18, C19, C32, C41	Capacitor, 1 μ F, 63V, Alum Axial	5400-13298-00	U1	Processor ADSP-2105-KP40
5040-09421-00	C52	Capacitor, 100 μ F, 25V, Alum Radial	5520-13301-00	Y1	Crystal 10MHz Parallel Resonant
5040-13417-00	C20, C21	Capacitor, 10,000 μ F, 35V, Alum Rad.	5551-09822-00	L1	Inductor, 4.7 μ H, 3Amp
5041-09009-00	C36, C44	Capacitor, 22 μ F, 10V, Tant Axial	5700-12047-00	U16	IC socket 24 pin 0.300 DIP
5041-13187-00	C22	Capacitor, 4.7 μ F Tant Axial	5700-12088-00	U2 - U9	IC socket 32 pin 0.600 DIP
5043-08996-00	C4, C5, C10-C13, C31, C35, C38, C43, C46, C47, C50 - C79	Capacitor, 0.10 μ F, Cer Axial	5705-12638-00	U27, U28	Heatsink 5298-B
5043-10267-00	C37, C45	Capacitor, 150pF, Cer Axial	5733-12060-01	-	Fuse Holder MT3AG(F501, F502)
5048-11028-00	C16, C17	Capacitor, 22pF, Cer Axial	5791-10862-04	J1, J2	Connector, 4-pin Header
5048-11029-00	C48	Capacitor, 100pF, Cer Axial	5791-10862-05	J3	Connector, 5-pin Header
5048-11030-00	C49	Capacitor, 470pF, Cer Axial	5791-10862-07	J4	Connector, 7-pin Header
5048-11033-00	C33	Capacitor, 0.022 μ F, 5%, Cer Axial	5791-12516-00	P1	Connector, 34 Hen 2 x 17 Str. 100
5048-12036-00	C34, C42	Capacitor, 0.22 μ F, Cer Axial	A-17002	U16	PAL Sub-Assembly
5048-13418-00	C30, C39, C40	Capacitor, .047 μ F, 5%, Cer Axial	A-5343-50028-2	U2	EPROM Sub-Assembly
5048-13608-00	C8	Capacitor, 6800 pF, 50V, Cer Axial	A-5343-50028-3	U3	EPROM Sub-Assembly
5048-13609-00	C7, C24, C26	Capacitor, 3900 pF, 50V, Cer Axial	A-5343-50028-4	U4	EPROM Sub-Assembly
5048-13610-00	C2, C3, C9, C27, C29	Capacitor, 1000 pF, 50V, Cer Axial	A-5343-50028-5	U5	EPROM Sub-Assembly
5048-13611-00	C6, C23, C25, C28	Capacitor, 680 pF, 50V, Cer Axial	A-5343-50028-6	U6	EPROM Sub-Assembly
5070-09045-00	D1 - D4	MR-501 Rectifier Diode	A-5343-50028-7	U7	EPROM Sub-Assembly
5070-09054-00	D5 - D9	1N4004 Signal Diode	Not Used	U8	EPROM Sub-Assembly
			Not Used	U9	EPROM Sub-Assembly
			5731-10356-00	F501, F502	Fuse, 3Amp, 250V, Slow Blow

A-15472-1 Fliptronic II Board

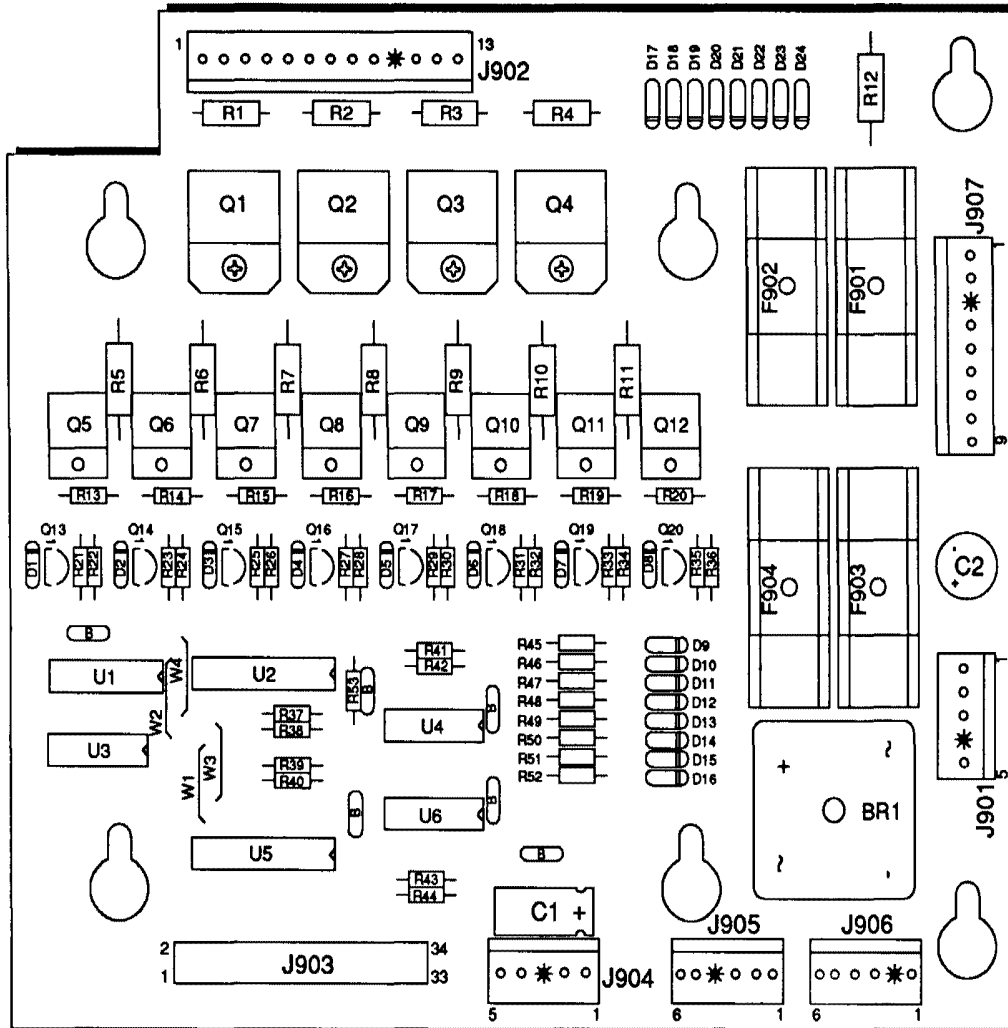

Part Number	Designator	Description	Part Number	Designator	Description
01-10572	Q1-Q4	Heatsink	5070-09054-00	D1 - D24	Diode 1N4004
20-9684	Q5-Q12	Fastener Snap	5162-12635-00	Q5-Q12	Transistor TIP102 NPN
4006-01003-08	Q1-Q4	Mach. Screw, 6-32	5190-09016-00	Q13 - Q20	Transistor 2N4403 PNP
4406-01128-00	Q1-Q4	Nut 6-32 KEPS	5191-12179-00	Q1-Q4	Transistor TIP36C PNP
5010-09034-00	R37 - R44, R53	Resistor, 10K Ω , 1/4w, 5%	5315-12009-00	U2	IC 74HCT374
5010-09358-00	R22, R24, R26, R28, R30, R32, R34, R36, R45 - R52	Resistor, 1K Ω , 1/4w, 5%	5315-12031-00	U5	IC 74HCT244
5010-09361-00	R1 - R4	Resistor, 220 Ω , 1/2w, 5%	5315-12812-00	U1	IC 74HCT138
5010-09416-00	R21, R23, R25, R27, R29, R31, R33, R35	Resistor, 470 Ω , 1/4w, 5%	5315-12951-00	U3	IC 74HCT00
5010-09534-00	W3, W4	Resistor, 0 Ω	5370-12272-00	U4, U6	IC LM339 QUAD COMP
5010-10171-00	R13 - R20	Resistor, 56 Ω , 1/4w, 5%	5791-10862-09	J907	Connector, 9-pin Header Sq. Pin
5011-12956-00	R5 - R12	Resistor, 2.7K Ω , 1w, 5%	5791-10862-05	J901, J904	Connector, 5-pin Header Sq. Pin
5040-08986-00	C1	Capacitor, 100M, 10v	5791-10862-13	J902	Connector, 13-pin Header Sq. Pin
5040-09537-00	C2	Capacitor, 100 μ F, 100v	5791-13830-06	J905, J906	Connector, Str Sq. Pin Header .100
5043-08980-00	B	Capacitor, .01 μ F, 50v	5791-12516-00	J903	34 HEN 2x17 STR
			5100-09690-00	BR1	Bridge Rectifier
			5731-10356-00	F901 - F904	Fuse S-B, 3A., 250v
			5733-12060-01		Fuse Holder (F901-F904)

A-14039 Dot Matrix Controller Assembly

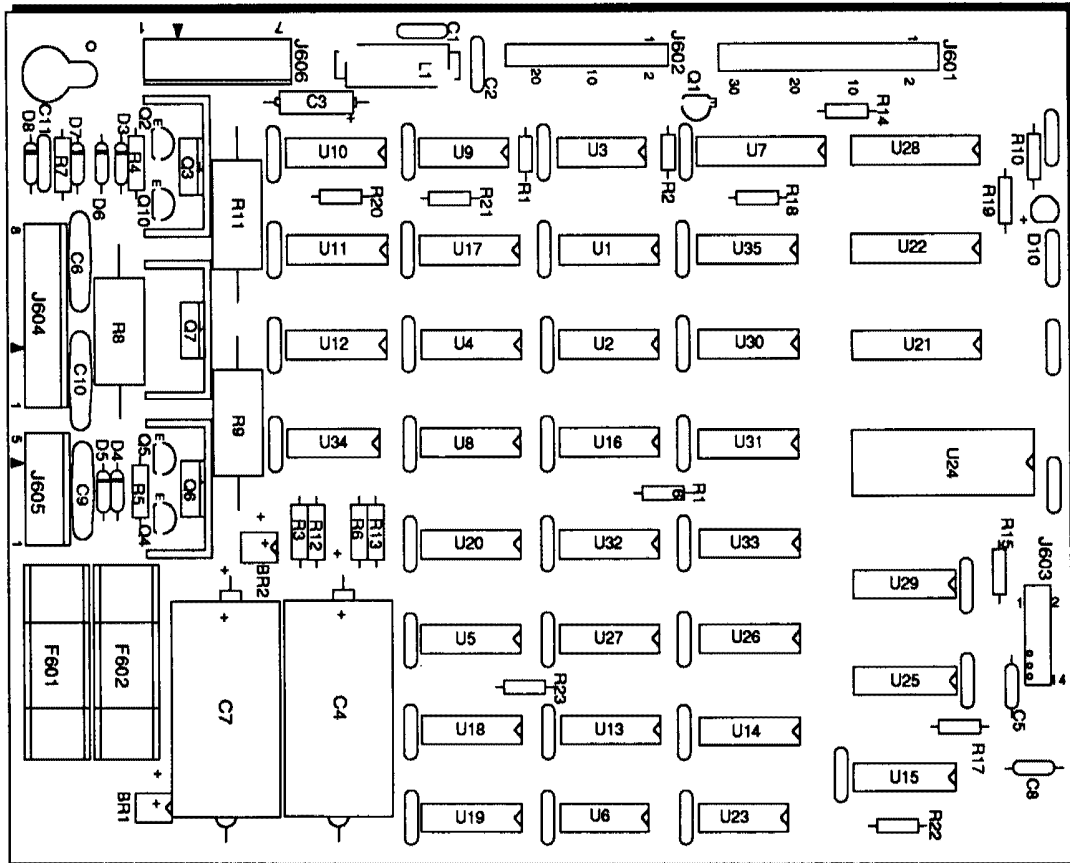

Part Number	Ckt Designator	Description	Part Number	Ckt Designator	Description
5010-08991-00	R1	Resistor, 4.7K Ω , 1/4w, 5%	5311-10947-00	U9	IC, 74HC125
5010-09224-00	R10	Resistor, 270 Ω , 1/4w, 5%	5311-10951-00	U10, U11	IC, 74HC161
5010-12832-00	R3, R6, R12, R13	Resistor, 47K Ω , 1/2w, 5%	5311-10977-00	U6	IC, 74HC04
5010-12841-00	R4, R5	Resistor, 120 Ω , 1/2w, 5%	5311-12817-00	U29	IC, 74HC165
5012-12830-00	R9	Resistor, 1.8K Ω , 5w, 5%	5311-12819-00	U21	IC, 74HC688
5012-12842-00	R11	Resistor, 120 Ω , 5w, 5%	5311-12820-00	U23	IC, 74HC27
5012-12843-00	R8	Resistor, 4.7K, 5w, 5%	5311-12822-00	U13 - U15	IC, 74HC193
5010-10171-00	R7	Resistor, 56 Ω , 1/4w, 5%	5315-12009-00	U22	IC, 74HCT374
5040-08986-00	C3	Capacitor, 100 μ fd., 10v, (\pm 20%)	5315-12812-00	U1, U2, U30	IC, 74HCT138
5040-12324-00	C4, C7	Capacitor, 150 μ fd., 160v, (\pm 50%)	5281-09308-00	U28	IC, 74HCT245
5043-08980-00	BYPASS	Capacitor, .01 μ fd., 50v, (+80, -20%)	5315-12815-00	U8, U34	IC, 74HCT08
5043-09072-00	C6, C9, C10	Capacitor, .1 μ fd., 500v, (+80, -20%)	5315-12816-00	U19	IC, 74HCT32
5043-09845-00	C1, C2, C11	Capacitor, 1KP, 50v, (\pm 20%)	5315-12821-00	U7	IC, 74HCT240
5043-09492-00	C5, C8	Capacitor, 100P, 50v, (\pm 10%)	5340-12278-00	U24	S/RAM 2064 150NS
5070-09054-00	D7	Diode, 1N4004, 1.0A.	5551-09822-00	L1	IND 4.7 μ H, 3.0A.
5075-12824-00	D6, D8	Zener, 1N4742A, 12v	5671-13732-00	D10	Display LED Red
5075-12823-00	D4, D5	Zener, 1N4758A, 56v	5705-09199-00	Q3, Q6, Q7	Heatsink 6030B
5075-12826-00	D3	Zener, 1N4759A, 62v	5731-12328-00	F601, F602	Fuse, 3/8A., SB, 250v
5100-12833-00	BR1, BR2	Bridge, 400v, 1A.	5733-12060-00		Fuse Holder (F601, F602)
5160-10269-00	Q1	Transistor, 2N3904 NPN	5791-10850-00	J602	Connector, 26-pin STR Sq.
5164-09056-00	Q2, Q10	Transistor, MPSD02, NPN	5791-10862-05	J605	Connector, 5-pin Header Sq.
5164-12154-00	Q3, Q7	Transistor, MJE15030 NPN	5791-10862-07	J606	Connector, 7-pin Header Sq.
5194-09055-00	Q4, Q5	Transistor, MPSD52 PNP	5791-10862-08	J604	Connector, 8-pin Header Sq.
5194-12155-00	Q6	Transistor, MJE15031 PNP	5791-12516-00	J601	34 Hen 17x2 STR
5281-09738-00	U16, U25 - U27	IC, 74LS157	5791-12827-00	J603	14 Hen 7x2 STR
5281-10033-00	U3	IC, 74LS90	5010-09036-00	R14-R23	Resistor, 100 Ω , 1/4w, 5%
5281-10043-00	U31 - U33, U35	IC, 74LS175	4006-01003-06	Q3, Q6, Q7	Mach. Screw, 6-32 x 3/8
5311-10946-00	U4, U5, U17, U18, U20	IC, 74HC74	4406-01128-00	Q3, Q6, Q7	Nut, 6-32 KEPS

A-12697-3 WPC Power Driver Assembly

<u>Part Number</u>	<u>Ckt Designator</u>	<u>Description</u>	<u>Part Number</u>	<u>Ckt Designator</u>	<u>Description</u>
4006-01005-06	Q1, Q2	Mach. Screw, 6-32 x 3/8	5040-12313-00	C5, C6, C7, C11, C30	Capacitor, 15,000µfd, 25v (±20%)
4406-01128-00	Q1, Q2	Nut, 6-32 KEPS	5043-08980-00	B-BYPASS	Capacitor, .01µfd, 50v (+80, -20%)
4004-01005-06	Q10, Q12, Q14, Q16, Q18	Mach. Screw, 4-40 x 3/8	5043-08986-00	C13-C20, C31	Capacitor, .1µfd, 50v (±20%)
4404-01119-00	Q10, Q12, Q14, Q16, Q18	Nut, 4-40 SNUT	5043-09845-00	C1, C12	Capacitor, 1,000µfd, 50v (±20%)
5010-08981-00	R260	Resistor, 10KΩ, 1/2w, 5%	5048-10894-00	C3	Capacitor, .33µfd, 50v (±20%) Ax.
5010-08991-00	R8, R12, R15, R18, R21, R23, R27, R31, R35, R39, R43, R47, R51, R55, R59, R63, R67, R71, R75, R79, R83, R87, R91, R95, R99, R126, R128, R130, R132, R134, R136, R138, R140, R227	Resistor, 4.7KΩ, 14w, 5%	5070-08919-00	D33, D34	Diode, 1N4148, 150MA.
5010-08992-00	R8, R11, R14, R17, R20, R177, R179, R181, R183, R185, R187, R189, R191	Resistor, 560Ω, 1/4w, 5%	5070-08054-00	D1-D3, D5-D12, D17-D32, D38	Diode, 1N4004, 1.0A.
5010-08993-00	R25, R29, R33, R37, R41, R45, R49, R53, R57, R61, R65, R69, R73, R77, R81, R85, R89, R93, R97, R101, R103, R106, R109, R112, R115, R118, R121, R124	Resistor, 68Ω, 1/4w, 5%	5100-08680-00	BR1-BR5	Bridge Rectifier, 35A., 200v
5010-08997-00	R24, R28, R32, R36, R40, R44, R48, R52, R56, R60, R64, R68, R72, R76, R80, R84, R88, R92, R96, R100, R102, R105, R108, R111, R114, R117, R120, R123, R195	Resistor, 2.7KΩ, 1/4w, 5%	5131-12725-00	Q10, Q12, Q14, Q16, Q18	Triac, BT138E
5010-08998-00	R155, R157, R159, R161, R165, R167, R169, R171	Resistor, 2.2KΩ, 1/4w, 5%	5162-12422-00	U19	IC, ULN 2803
5010-09034-00	R3, R4, R6, R142-R149, R197, R198	Resistor, 10KΩ, 1/4w, 5%	5162-12635-00	Q20, Q22, Q24, Q26, Q28, Q30, Q32, Q34, Q36, Q38, Q40, Q42, Q44, Q46, Q48, Q50, Q52, Q54, Q56, Q58, Q63, Q65, Q67, Q69, Q75, Q77, Q79, Q81, Q83 - Q80	Transistor, TIP 102
5010-09085-00	R194, R196, R251, R253-R257	Resistor, 1.5KΩ, 1/4w, 5%	5194-09055-00	Q9, Q11, Q13, Q15, Q17, Q19, Q21, Q23, Q25, Q27, Q29, Q31, Q33, Q35, Q37, Q39, Q41, Q43, Q45, Q47, Q49, Q51, Q53, Q55, Q57, Q59-Q62, Q71-Q74	Transistor, 2N5401 PNP
5010-09086-00	R252	Resistor, 6.8KΩ, 1/4w, 5%	5191-12179-00	Q64, Q66, Q68, Q70, Q76, Q78, Q80, Q82	Transistor, TIP36C PNP
5010-09224-00	R1, R2, R192, R201, R205, R208	Resistor, 270Ω, 1/4w, 5%	5192-12428-00	Q91-Q98	Transistor, TIP 107
5010-09314-00	R176, R178, R180, R182, R184, R186, R188, R190	Resistor, 1.2KΩ, 1/4w, 5%	5250-12634-00	Q1	Reg LM 323 5v
5010-09324-00	R206	Resistor, 27KΩ, 1/4w, 5%	5281-09486-00	U1-U5, U18	IC, 74LS374 8 Dual D Flipflop
5010-09358-00	R154, R156, R158, R160, R164, R166, R168, R170, R162, R193, R199, R200	Resistor, 1KΩ, 1/4w, 5%	5281-09487-00	U10-U13	IC, 74LS74 Dual D flipflop
5010-09361-00	R104, R107, R110, R113, R116, R119, R122, R125	Resistor, 27KΩ, 1/4w, 5%	5281-10182-00	U9	IC, 74LS240, L/Drv
5010-09416-00	R22, R26, R30, R34, R38, R42, R46, R50, R54, R58, R62, R66, R70, R74, R78, R82, R86, R90, R94, R98, R127, R129, R131, R133, R135, R137, R139, R141	Resistor, 1KΩ, 1/4w, 5%	5370-12272-00	U6, U15, U16	IC, LM339 Quad. Comp
5010-09534-00	W1, W2	Resistor, 0Ω	5460-12423-00	Q2	IC, LM 7812
5010-11079-00	R7, R10, R13, R16, R19	Resistor, 51Ω, 1/4w, 5%	5671-13732-00	LED1 - LED7	Display LED Red
5010-12427-00	R150-R153, R172-R175	Resistor, .22Ω, 1w, 5%	5701-09652-00	Q1	Thermal Pad TO-3
5012-12632-00	R224	Resistor, .12Ω, 10w, 5%	5705-09199-00	Q2	Heatsink, #6030E
5019-10143-00	SR1	SIP, 9P, 10 pin, 470Ω, 5%	5705-12637-00	Q1	Heatsink 5054
5040-08986-00	C4	Capacitor, 100µfd, 10v (±20%)	5705-12638-00	Q10, Q12, Q14, Q16, Q18	Heatsink 5298B
5040-09421-00	C2	Capacitor, 100µfd, 25v (+50, -10%)	5733-12060-01	J108, J119, J136	Fuse Holder, F101-F116
5040-09537-00	C8	Capacitor, 100µfd, 100v (±20%)	5791-10862-03	J103, J116-J118	Connector, 3-pin Header STR Sq.
			5791-10862-04	J112, J104-J106, J123, J124, J128, J129, J131, J132	Connector, 4-pin Header STR Sq.
			5791-10862-05	J128, J129, J131, J132	Connector, 5-pin Header STR Sq.
			5791-10862-06	J107	Connector, 6-pin Header STR Sq.
			5791-10862-07	J101, J109, J114	Connector, 7-pin Header STR Sq.
			5791-10862-09	J102, J122, J125, J127, J130, J137, J138	Connector, 9-pin Header STR Sq.
			5791-10862-11	J120, J121	Connector, 11-pin Header STR Sq.
			5791-10862-12	J115	Connector, 12-pin Header STR Sq.
			5791-10862-13	J126	Connector, 13-pin Header STR Sq.
			5791-13830-05	J111	Connector, 5-pin Header STR Sq.
			5791-13830-09	J133-J135	Connector, 9-pin Header STR Sq.
			5791-12516-00	J113	34 HEN 2x17 STR
			5824-09248-00	TP1-TP8	Test Point #1502-1
			5041-09163-00	C9	Capacitor, 2.2µfd TANT
			5730-09071-00	F114	Fuse, 8A, 32v
			5731-09432-00	F112	Fuse, S-B, 7A., 250v
			5731-09651-00	F106 - F111, F113	Fuse, S-B, 5A., 250v
			5731-10356-00	F101 - F105, F116	Fuse, S-B, 3A., 250v
			5730-09797-00	F115	Fuse, S-B, 3/4A., 250v
			5705-12698-00		Heatsink #62365
			4010-01006-00		Mach. Screw, 10-32 x 5/8

A-12697-3 WPC Power Driver Assembly

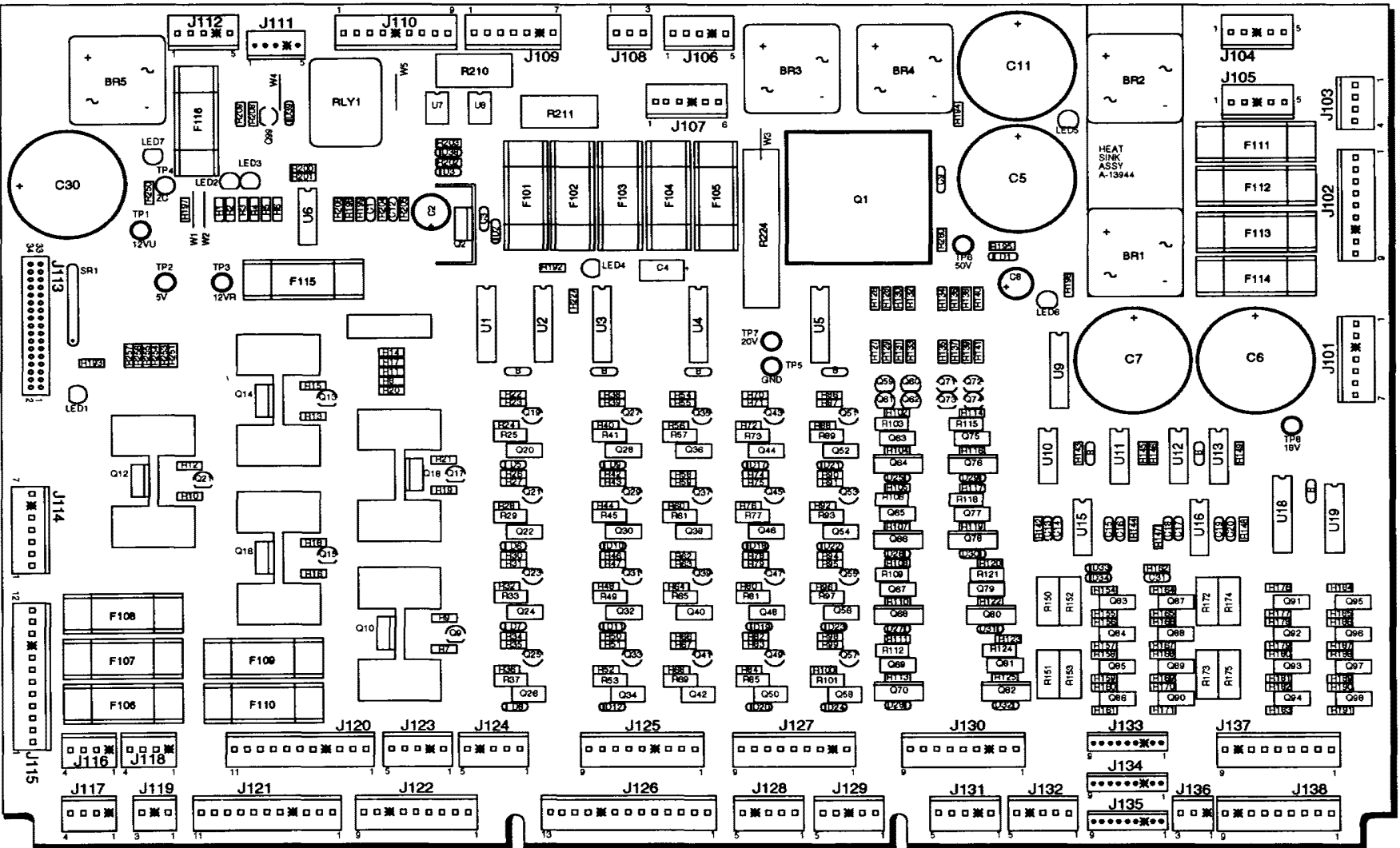

A-12742-50028 WPC CPU Board Assembly

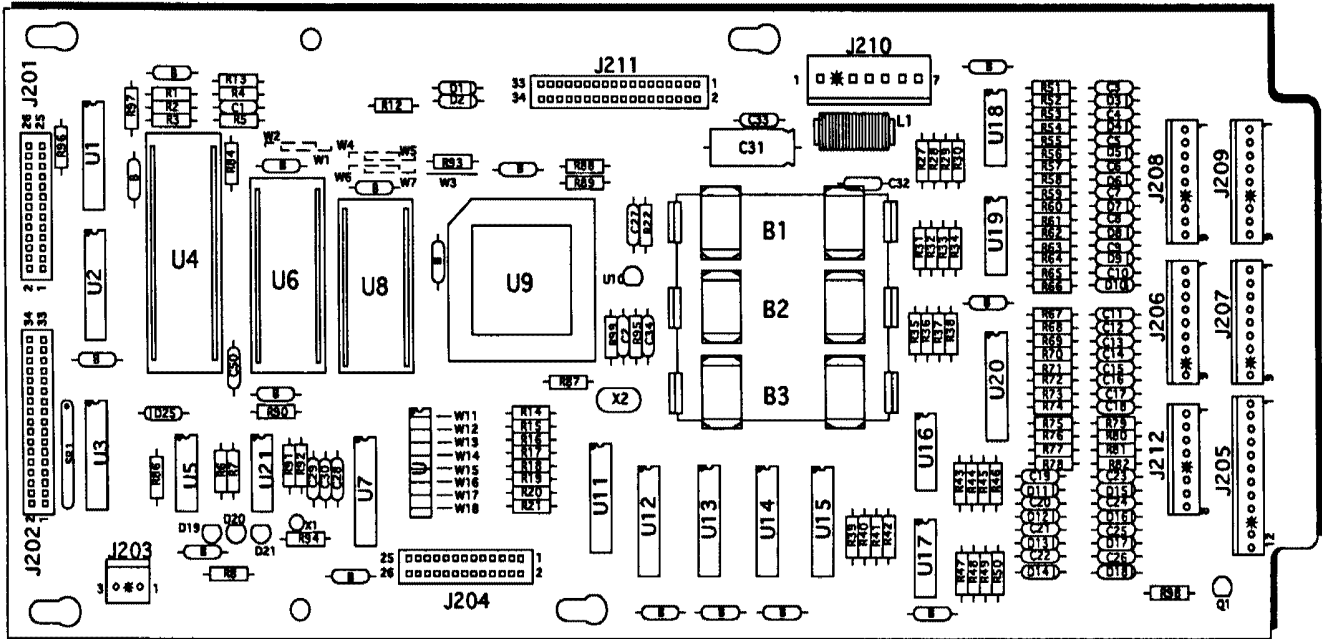

Part Number	Designator	Description	Part Number	Designator	Description
5010-09034-00	R14-R22, R27-R42, R86, R90, R94, R98	Resistor, 10K Ω , 1/4w, 5%	5281-09851-00	U5	IC, 74LS14, SMT/TRG
5010-09085-00	R1, R2, R4, R96, R97	Resistor, 1.5K Ω , 1/4w, 5%	5281-09867-00	U1, U2, U7	IC, Octal Buffer, 74LS244
5010-09314-00	R52, R54, R56, R58, R60, R62, R64, R66, R75-R82	Resistor, 1.2K Ω , 1/4w, 5%	5281-10182-00	U11, U12, U13, U15	IC, 74LS240 Driver
5010-09358-00	R3, R43-R51, R53, R55, R57, R59, R61, R63, R65, R67-R74, R84	Resistor, 1K Ω , 1/4w, 5%	5284-12651-00	U21	IC, 4584
5010-09416-00	R5-R8, R12, R13, R87-R89	Resistor, 470 Ω , 1/4w, 5%	5340-13062-00	U8	IC/RAM 32K x 8
5010-09534-00	W1, W3, W4, W7	Resistor, 0 Ω	5370-12272-00	U16 - U19	IC, LM339, Quad. Comp
5010-10258-00	R95, R99	Resistor, .01 μ f Ω , 1/4w, 5%	5370-12687-00	U10	MC, 34064 Reset Chip
5010-10989-00	R92	Resistor, 470K Ω , 1/4w, 5%	5520-10438-00	X2	Crystal, 8.0MHz.
5010-12104-00	R91	Resistor, 22 μ f Ω , 1/4w, 5%	5520-12084-00	X1	Crystal 32.768 KHz
5019-09362-00	SIP 1	SIP, 9R, 10-pln, 4.7K Ω , 5%	5551-09822-00	L1	ILN, 4.7 UH 3A
5040-08986-00	C31	Capacitor, 100 μ f Ω , 10v (\pm 20%)	5671-13732-00	D19 - D21	DSPL LED RED
5043-08980-00	B	Capacitor, .01 μ f Ω , 50v, (+80, -20%)	5700-08985-00	U4	Socket, IC 40P, .6"
5043-09030-00	C27	Capacitor, 0.047 μ f Ω , 50v (\pm 20%)	5700-12088-00	U6	Socket, IC 32P, .6"
5043-09065-00	C3 - C26	Capacitor, 470pfd, 50v (\pm 20%)	5700-12424-00	U9	Socket, 84 Pin PLCC
5043-09491-00	C2, C29, C30, C34	Capacitor, 22pfd, 1KV, (\pm 10%)	5791-10850-00	J201, J204	Connector, 26-pin Header Str Sq.
5043-09492-00	C28	Capacitor, 100pfd, 50v, (\pm 10%)	5791-10862-07	J210	Connector, 7-pin Header Str Sq.
5043-09845-00	C32, C33	Capacitor, 1KP, 50v, (\pm 20%)	5791-13830-08	J212	Connector, 8-pin Header Str Sq.
5070-08919-00	D2 - D18	Diode, 1N4148, 150MA	5791-13830-09	J206 - J209	Connector, 9-pin Header Sq. pin
5070-09266-00	D1, D25	Diode, 1N5817, 1.0A.	5791-13830-12	J205	Connector, 12-pin Header Sq. pin
5160-10269-00	Q1	Transistor, 2N3904, NPN	5791-12516-00	J202, J211	34 Hen 2x17 STR
5162-12422-00	U20	IC, ULN, 2803A	A-15814	B1 - B3	Battery Holder "AA"
5281-09308-00	U3	IC, 74LS245, Octal Bus Trmcv	5048-11033-00	C50	Capacitor, 0.022 μ f, 10v
5281-09486-00	U14	IC, 74LS374, 8D F/F	A-5343-50028-1	U6	Game PROM Assembly
			5410-12426-00	U9	WPC-89 ASIC
			5400-10320-00	U4	IC MPU 68B09E
			5880-09022-00	B1 - B3	Battery, Alkaline, 1.5v ("AA")
			5645-09025-00	W11 - W18	Switch Dip 8 Pos

A-17982 7 Ball Trough LED PCB Assembly

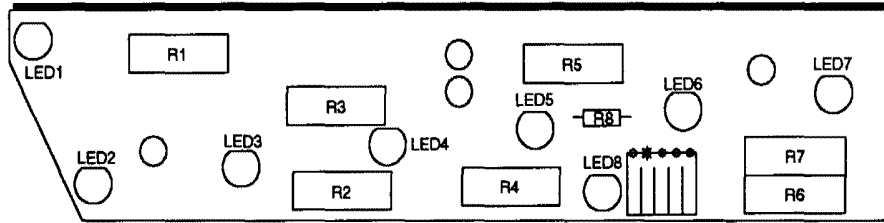

<u>Part Number</u>	<u>Designator</u>	<u>Description</u>
5791-13830-05	J1	Connector, 5-pin Header
5671-12731-00	LED1 - LED7	Diode-Infra Red
5010-12928-00	R1 -R7	Resistor, 270Ω, 2W, 5%
5671-13732-00	LED8	Display LED Red
5010-09314-00	R8	Resistor, 1.2KΩ, 1/4W, 5%

A-17981 7 Ball Trough Photo Transistor Assy.

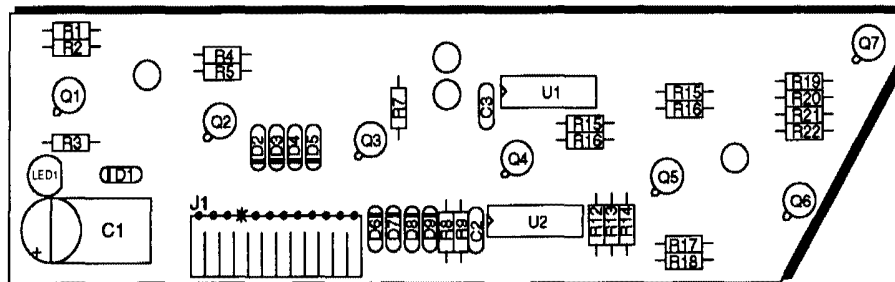

<u>Part Number</u>	<u>Designator</u>	<u>Description</u>
5163-12732-00	Q1 - Q7	Photo Transistor
5791-12622-12	J1	Connector, 12-pin Header
5010-09999-00	R1, R2, R4-R7, R10, R11, R15, R16, R19-R22	Resistor, 2KΩ, 1/4W, 5%
5010-09314-00	R3	Resistor, 1.2KΩ, 1/4W, 5%
5010-09162-00	R18, R8, R13	Resistor, 100KΩ, 1/4W, 5%
5010-08774-00	R9, R17	Resistor, 22KΩ, 1/4W, 5%
5010-09034-00	R12	Resistor, 10KΩ, 1/4W, 5%
5070-09054-00	D1 - D9	Diode 1N4004, 1.0A
5370-12272-00	U1, U2	ICLM339 Quad
5671-13732-00	LED1	Display LED Red
5043-08980-00	C2, C3	Capacitor, 0.01μF, 50V
5040-12298-00	C1	Capacitor, 100μFd, 40V (±50%)

A-17051-1 Coin Door Interface PCB Assembly

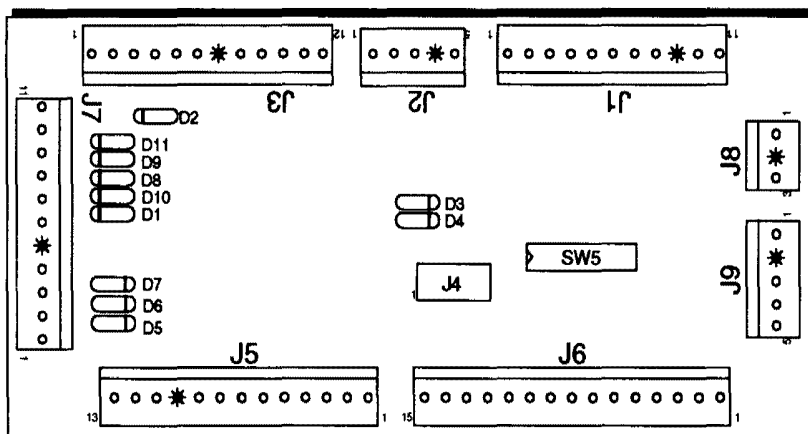

<u>Part Number</u>	<u>Designator</u>	<u>Description</u>
5791-10862-03	J8	Connector, 3-pin Header Str Sq. pin .156
5791-10862-05	J2, J9	Connector, 5-pin Header Str Sq. pin .156
5791-10862-11	J1, J7	Connector, 11-pin Header Str Sq. pin .156
5791-10862-12	J3	Connector, 12-pin Header Str Sq. pin .156
5791-10862-13	J5	Connector, 13-pin Header Str Sq. pin .156
5791-10862-15	J6	Connector, 15-pin Header Str Sq. pin .156
5645-09025-00	SW5	Sw DIP 8 Pos
5070-09054-00	D1 - D11	Diode, 1N4004, 1.0A.
5791-11000-10	J4	Connector, 10-pin Header Str Sq. pin .156

A-15542 Motor EMI PCB Assembly

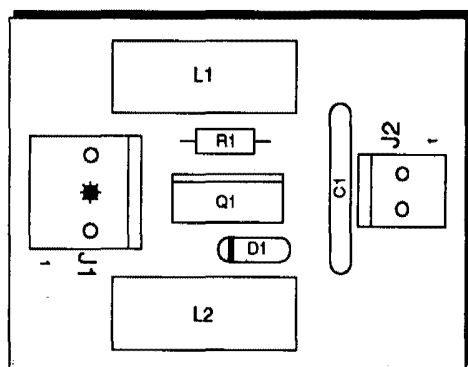

<u>Part Number</u>	<u>Designator</u>	<u>Description</u>
5551-09822-00	L1, L2	Ind. 4.7MH3AMP
5791-12273-03	J1	Connector, 3-pin Header Sq.
5791-12273-02	J2	Connector, 2-pin Header Sq.
5070-09054-00	D1	Diode 1N4004, 1.0A.

A-17316 Flipper Opto PCB Assembly

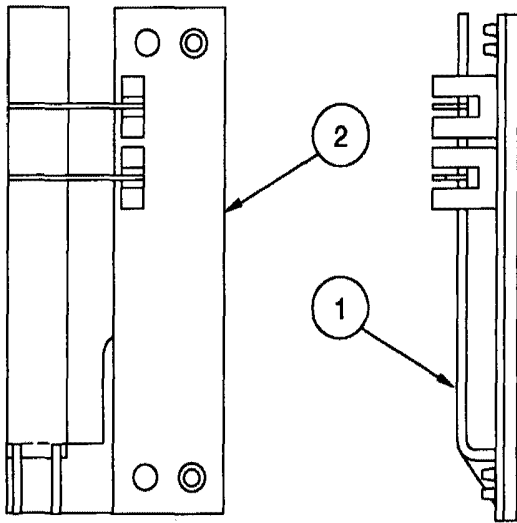

Item	Part Number	Description
1.	03-9001	Interrupter Flip-Opto
2.	A-16384	Flipper Opto Switch Assembly
	5010-08930-00	Resistor, 470Ω, 1/2w, 5%
	5490-12451-00	Opto Inter Lg. 10mA.
	5791-12462-07	Connector, 7-pin Header

A-16120 DC Motor Control Assembly

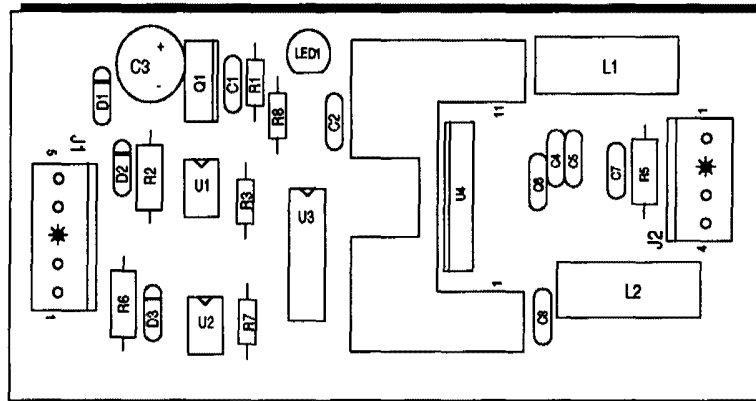

Part Number	Designator	Description	Part Number	Designator	Description
5791-12273-04	J2	Connector, 4-pin Header	55040-10974-00	C3	Capacitor, 100μFd, 35v Rad
5791-12273-05	J1	Connector, 5-pin Header	5370-13342-00	U4	IC 3A D.OS Bridge Driver
5671-09019-00	LED1	Display Red LED	5490-10892-00	U1, U2	Opto Isolator 4N25
5070-09054-00	D1 - D3	Diode 1N4004 1.0A.	5250-09157-00	Q1	Reg. 7805 1.0A, 5V
5551-09822-00	L1, L2	Ind. 4.7mH, 3.0A.	5043-08980-00	C2, C4, C6-C8	Cap., .01μFd, 50v (+80, -20%)
5010-09061-00	R2, R6	Resistor, 680Ω, 1/2w, 5%	5041-09031-00	C1	Cap., 1μFd, 25v (±20%) Axial
5010-10255-00	R5	Resistor, 10Ω, 1/2w, 5%	5281-09500-00	U3	IC 74LS32 Quad
5010-08997-00	R3, R7, R8	Resistor, 2.7KΩ, 1/2w, 5%	5043-08996-00	C5	Capacitor, .1M, 50V (±20%)
5010-09085-00	R1	Resistor, 1.5KΩ, 1/2w, 5%			

A-15576 7-Switch Opto PCB Assembly

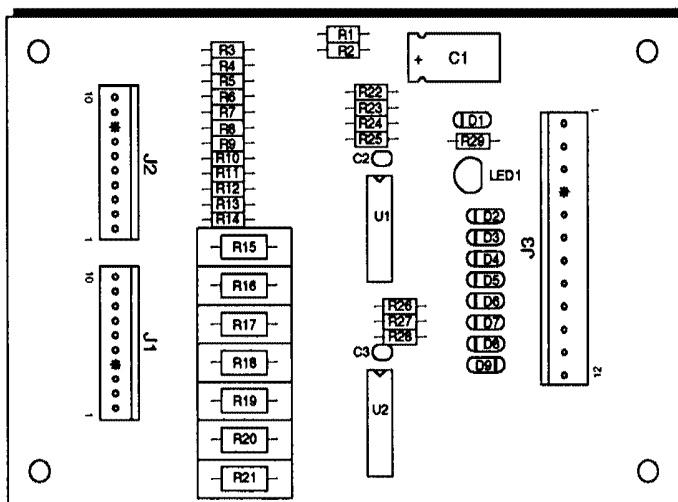

<u>Part Number</u>	<u>Designator</u>	<u>Description</u>	<u>Part Number</u>	<u>Designator</u>	<u>Description</u>
5040-12298-00	C1	Cap., 100µfd, 40v (±50%)	5010-10631-00	R29	Resistor, 1.2KΩ, 2w, 5%
5043-08980-00	C2, C3	Capacitor, .01 M 50v	5010-09162-00	R23, R25, R26	Resistor, 100KΩ, 2w, 5%
5671-09019-00	LED 1	Display LED Red	5010-08774-00	R22, R24	Resistor, 22KΩ, 1/4w, 5%
5370-12272-00	U1, U2	IC LM339 Quad.	5010-09034-00	R28	Resistor, 10KΩ, 1/4w, 5%
5070-09054-00	D1 - D9	Diode 1N4004 1.0A.	5791-10862-12	J3	Connector, 12-pin Header Str Sq.
5010-12928-00	R15 - R21	Resistor, 270KΩ, 2w, 5%	5791-12462-10	J1, J2	Connector, 10-pin Header Str Sq.
5010-09999-00	R1 - R14	Resistor, 2KΩ, 2w, 5%			

A-16986 Cryoclaw Opto Assembly

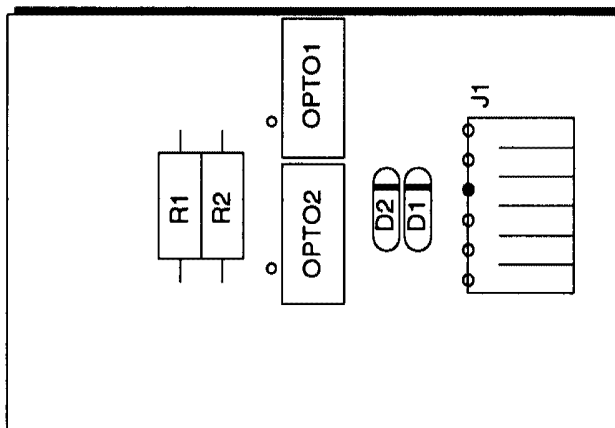

<u>Part Number</u>	<u>Designator</u>	<u>Description</u>
5791-12622-06	J1	Connector, 6-pin Header
5010-08930-00	R1, R2	Resistor, 470Ω, 1/2w, 5%
5070-09054-00	D1, D2	Diode 1N4004, 1.0A
5490-12451-00	OPTO1, OPTO2	Opto Inter Lg 10MA

A-16100-2 Aux. Driver PCB Assembly

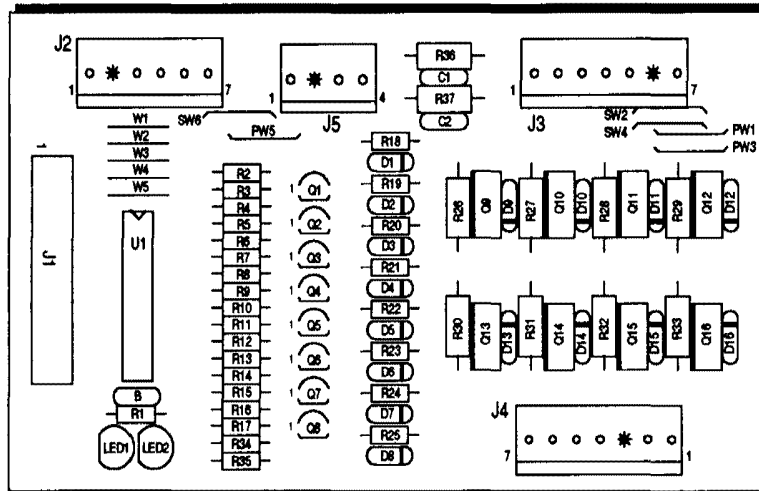

<u>Part Number</u>	<u>Designator</u>	<u>Description</u>	<u>Part Number</u>	<u>Designator</u>	<u>Description</u>
5317-13400-00	U1	IC74ALS576 O/F-F	5010-09314-00	R35	Resistor, 1.2KΩ, 1/4w, 5%
5190-09016-00	Q1 - Q8	Trans. 2N4403 PNP	5010-09224-00	R34	Resistor, 270Ω, 1/4w, 5%
5162-12635-00	Q9 - Q16	Trans. TIP 102NPN	5671-09019-00	LED1, LED2	Disp. Red LED
5070-09054-00	D1- D16	Diode, 1N4004, 1.0A.	5010-08930-00	R37	Resistor, 470Ω, 1/2w, 5%
5010-08991-00	R1, R2, R4, R6, R8, R10, R12, R14, R16	Resistor, 4.7KΩ, 1/4w, 5%	5043-09065-00	C2	Cap., 470PF, 50v(±20%)
5010-09416-00	R3, R5, R7, R9, R11, R13, R15, R17	Resistor, 470Ω, 1/4w, 5%	5010-09534-00	W4, PW1, PW3, PW5	Resistor, 0Ω (Jumper)
5043-08980-00	B	Cap., .01μF, 50v(+80, -20%)	5791-10850-00	J1	Connector, 26-pin Header
5010-10171-00	R18 - R25	Resistor, 56Ω, 1/4w, 5%	5791-10862-06	J2	Connector, 6-pin Header
5011-12956-00	R26 - R33	Resistor, 2.7KΩ, 1/4w, 5%	5791-10862-07	J3, J4	Connector, 7-pin Header
			5791-10862-04	J5	Connector, 4-pin Header

A-17596 Elevator Opto Assembly

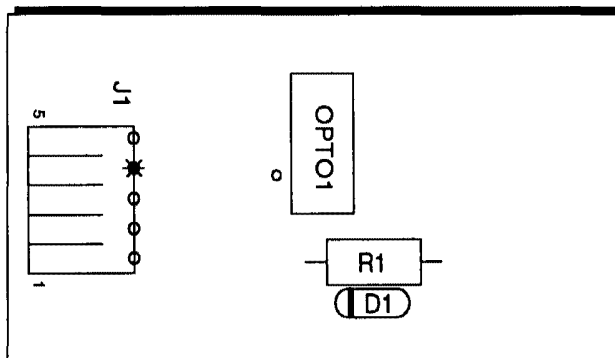

<u>Part Number</u>	<u>Designator</u>	<u>Description</u>
5791-12622-05	J1	Connector, 5-pin Header
5010-08930-00	R1	Resistor, 470Ω, 1/2w, 5%
5070-09054-00	D1	Diode 1N4004, 1.0A
5490-12451-00	OPTO1	Opto Inter Lg 10MA

A-15849-R-2 & A-15849-L-2 Flipper Assembly

<u>Item</u>	<u>Part Number</u>	<u>Description</u>	<u>Item</u>	<u>Part Number</u>	<u>Description</u>
1.	B-13104-R B-13104-L	Flipper Base Assy., Right Flipper Base Assy., Left	16.	A-15848-R A-15848-L	Crank Link Assembly, Right Crank Link Assembly, Left
2.	SW-1A-194	Switch Assembly	a)	A-17050-R A-17050-L	Flipper Crank Assembly, Right Flipper Crank Assembly, Left
3.	4701-00002-00	Lockwasher, #6 Split	b)	A-15847	Flipper Link Assembly
4.	4105-01019-10	Sh. Metal Screw, #5 x 5/8 P-RH-A	c)	02-4676	Link Spacer Bushing
5.	4008-01079-05	Mach. Screw, 8-32 x 5/16 H-SOC	d)	4010-01086-14	Cap Screw, 10-32 x 7/8 SH
6.	4701-00003-00	Lockwasher, #8 Split	e)	4700-00023-00	Flatwasher, 5/8 x 13/64 x 16ga.
7.	01-9375	Switch Mounting Bracket	f)	4701-00004-00	Lockwasher #10 Split
8.	20-6516	Speednut, Tinnerman	g)	4410-01132-00	Nut, 10-32 ESN
9.	4010-01066-06	Cap Screw, 10-32 x 3/8, SH	17.	23-6577	Bumper Plug, 5/8"
10.	4701-00004-00	Lockwasher, #10 Split	18.	03-7568	Flipper Bushing
11.	A-12390	Flipper Stop Assembly	19.	4006-01005-06	Mach. Screw, 6-32 x 3/8 P-PH
12.	FL-11629	Flipper Coil (Blue)	20.	4406-01117-00	Nut, 6-32 Hex
a)	03-7066-5	Coil Tubing	■ Associated Parts for Left & Right Flippers:		
13.	01-7695	Solenoid Bracket	21.	23-6519-4	Flipper Rubber Ring, Red (3 used)
14.	4006-01017-04	Mach. Screw, 6-32 x 1/4 P-RH-S	22.	20-9250-5	Flipper & Shaft-White (3 used)
15.	10-364	Spring			

A-14876-L Flipper Assembly (The parts listed replace same items of A-15849-L-2)

<u>Item</u>	<u>Part Number</u>	<u>Description</u>
1.	A-14877-L	Flipper Base Assy., Left
2.	SW-1A-193	Switch Assembly
3.	FL-11630	Flipper Coil (Red)

Flipper Assembly

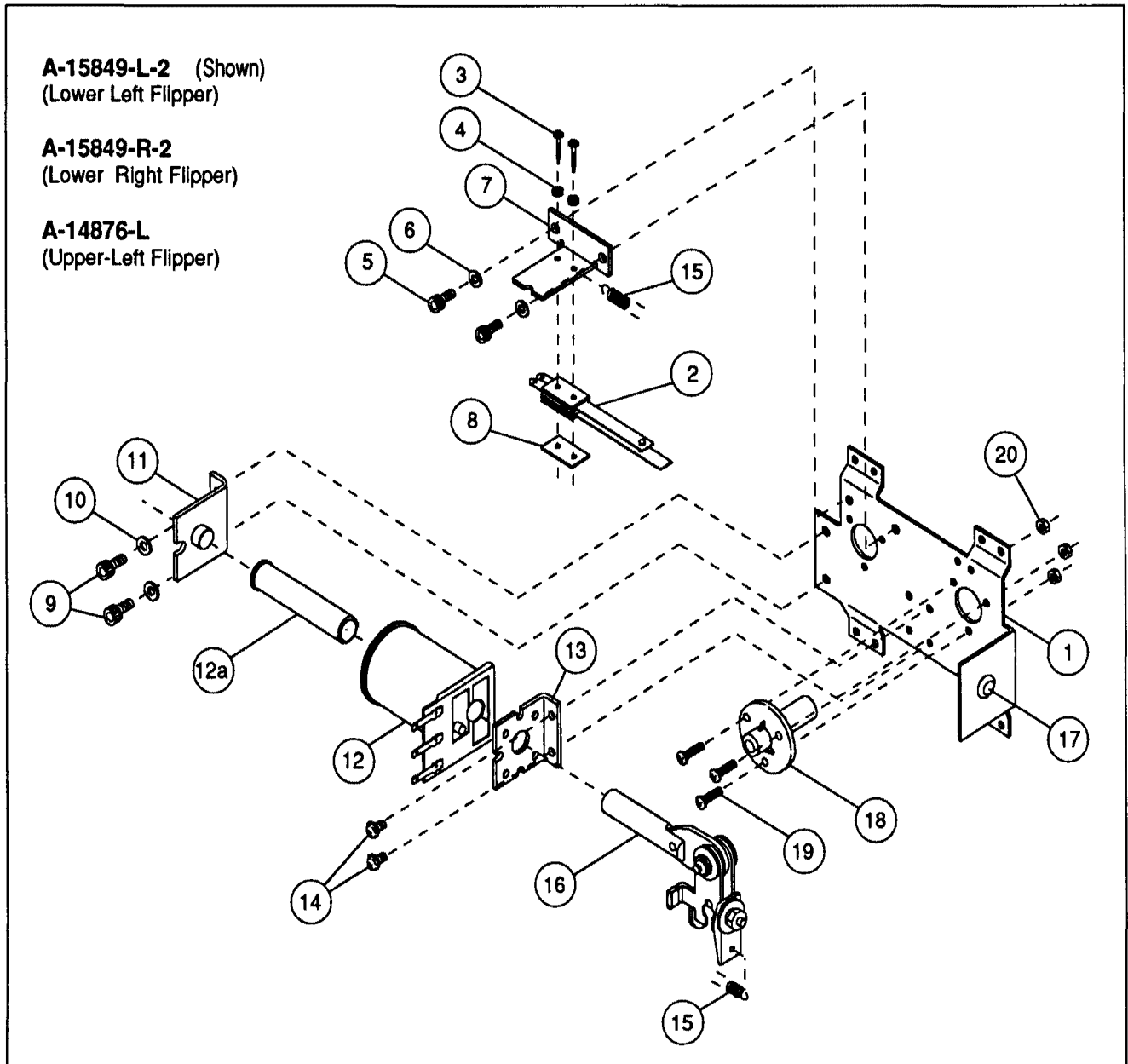

■ **Flipper Notes:**

1. Each Flipper Assembly is mounted beneath the playfield, in conjunction with the Plastic Flipper & Shaft, and Flipper Rubber on the upper side of the playfield.
2. With the flipper, in the non-activated position, the E.O.S. Switch contacts must have a gap of $.062 (\pm 015)$ inch. When flipper is activated switch must close.
3. Any adjustment of the E.O.S. Switch must be made at a minimum distance of 0.25 inch from the switch body.
4. Longer blade of E.O.S. Switch must be straight. Gap adjustment is done by adjusting shorter blade.
5. All moving elements of the assembly must operate freely without any evidence of binding.
6. Apply Loctite™ 245 when reattaching screws to the Flipper Stop Assembly, the Solenoid Bracket, and the Flipper Bushing.

A-17811 Kicker Arm (Slingshot) Assembly

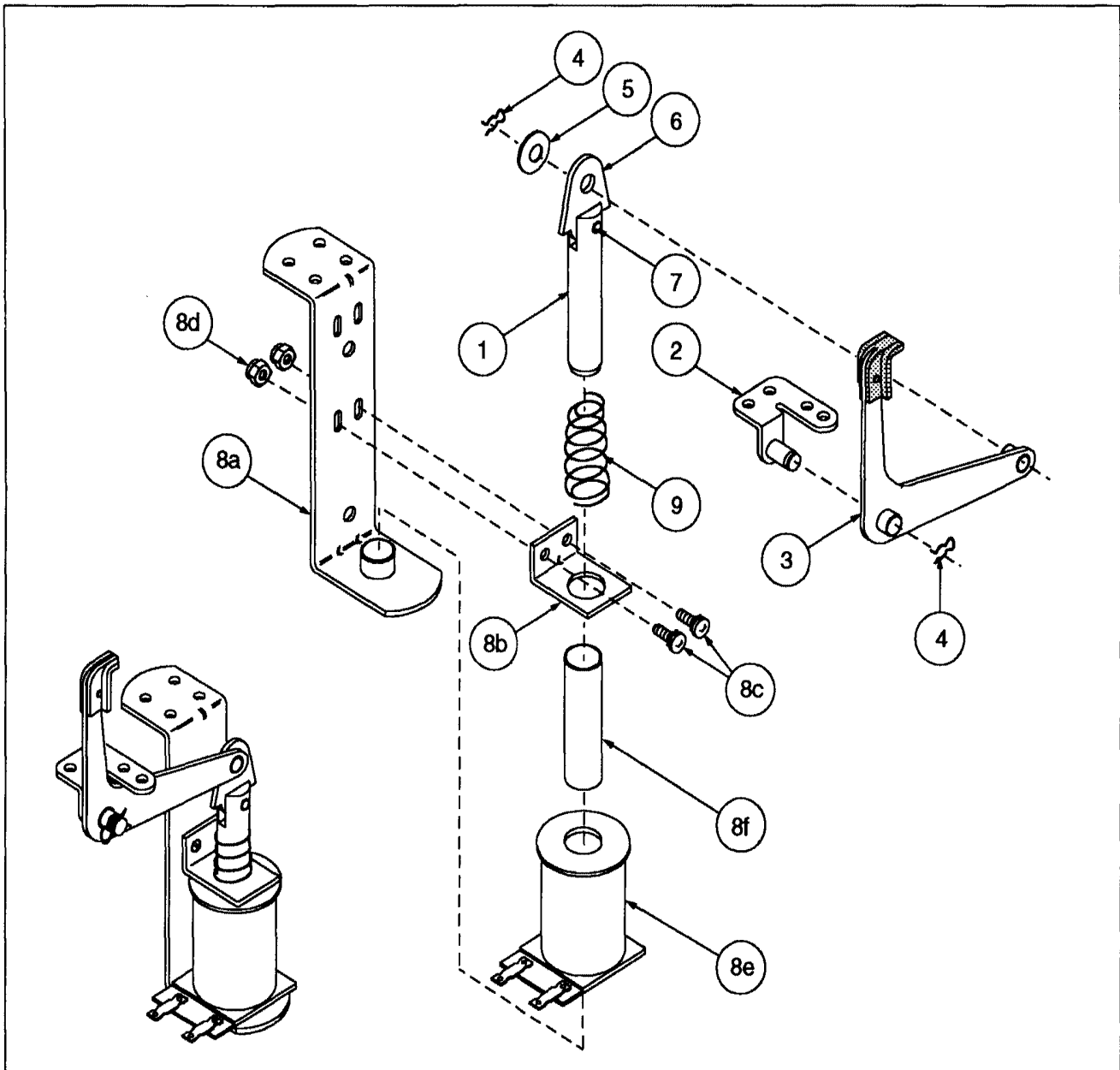

■ Associated Parts for Right & Left Kickers:

Item	Part Number	Description	Item	Part Number	Description
1.	02-2364	Coil Plunger	8.	A-17809	Coil & Bracket Assy., Right
2.	A-17810	Mounting Bracket Assembly		A-17809-1	Coil & Bracket Assy., Left
3.	A-12664	Kicker Crank Assembly	a)	A-17808	Bracket & Stop Assembly
4.	12-6227	Hairpin Clip	b)	01-8-508-S	Coil Retaining Bracket
5.	4700-00030-00	Flatwasher, 17/64 x 1/2 x 15ga	c)	4006-01017-06	Mach. Screw, 6-32 x 3/8
6.	03-8085	Armature Link	d)	4406-01119-00	Nut, 6-32 ESN
7.	20-8716-5	Roll Pin, 1/8 x 7/16"	e)	AE-26-1200	Coil Assembly
			f)	03-7066	Coil Tubing
			9.	10-128	Spring

A-16765-1 Outhole Ball Trough Assembly

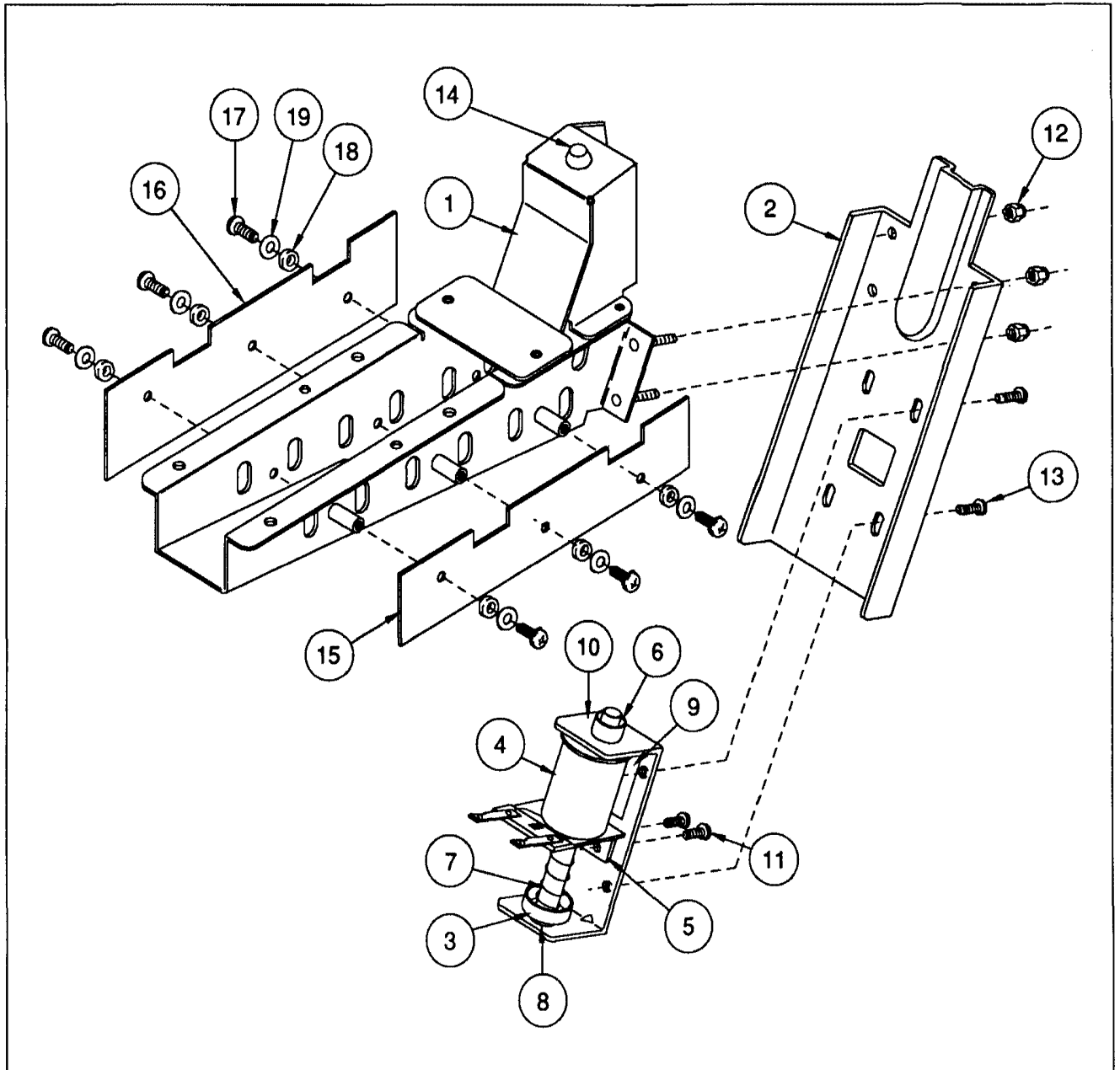

<u>Item</u>	<u>Part Number</u>	<u>Description</u>	<u>Item</u>	<u>Part Number</u>	<u>Description</u>
1.	A-16809	Ball Trough Welded Assy.	11.	4008-01017-05	Mach. Screw, 8-32x5/16 P-RH SEMS
2.	01-11587	Ball Trough Front	12.	4408-01119-00	Nut 8-32 ESN
3.	A-6306-2	Bell Armature Assembly	13.	4008-01017-06	Mach. Screw, 8-32x3/8 P-RH SEMS
4.	AE-26-1500	Coil Assembly	14.	23-6702	Bumper Plug
5.	01-8-508-T	Solenoid Bracket	15.	A-17982	7 IR LED PCB Assembly
6.	03-7067-5	Coil Tubing	16.	A-17981	7 IR LED PCB Assembly
7.	10-135	Insulator	17.	4006-01017-06	Mach. screw, 6-32x3/8 P-RH SEMS
8.	23-6420	Rubber Grommet	18.	23-6626	Rubber Grommet
9.	03-8523	Insulator	19.	4700-00016-00	Flatwasher, 3/16 x 7/16 x 17ga.
10.	01-11586	Coil Mtg. Bracket (Bell)			

B-9414 Jet Bumper Assembly

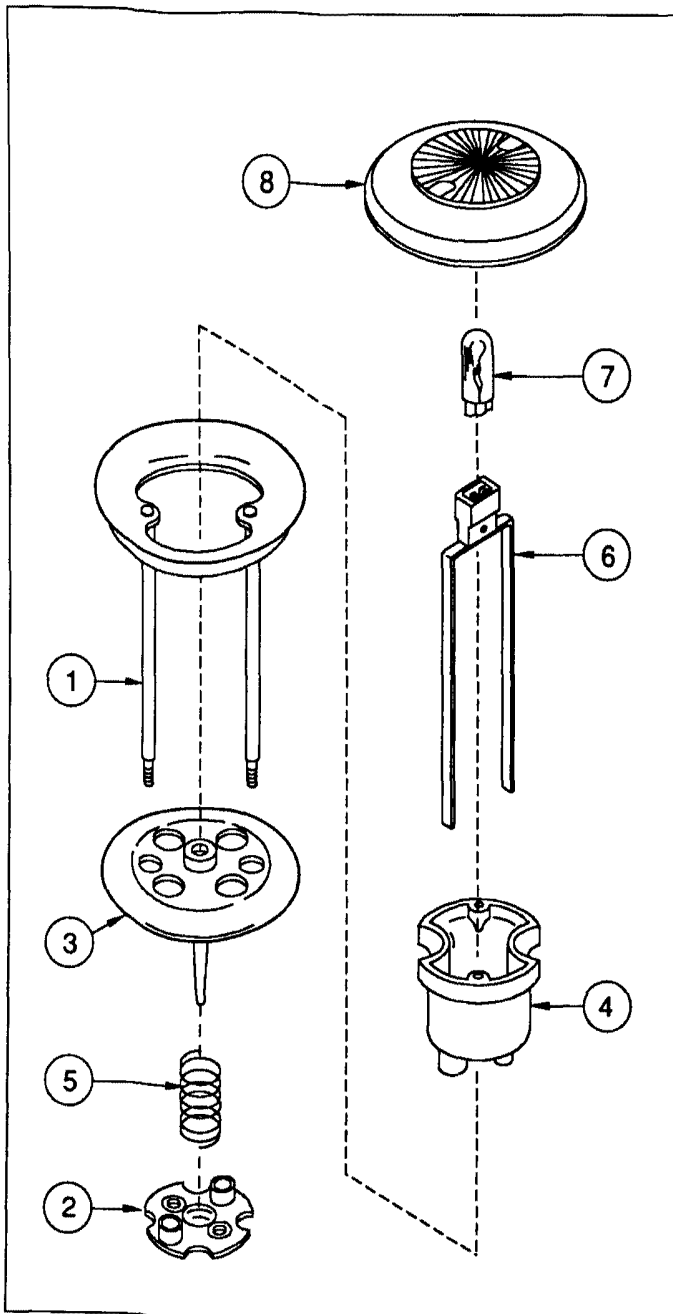

A-9415-2 Jet Bumper Coil Assembly

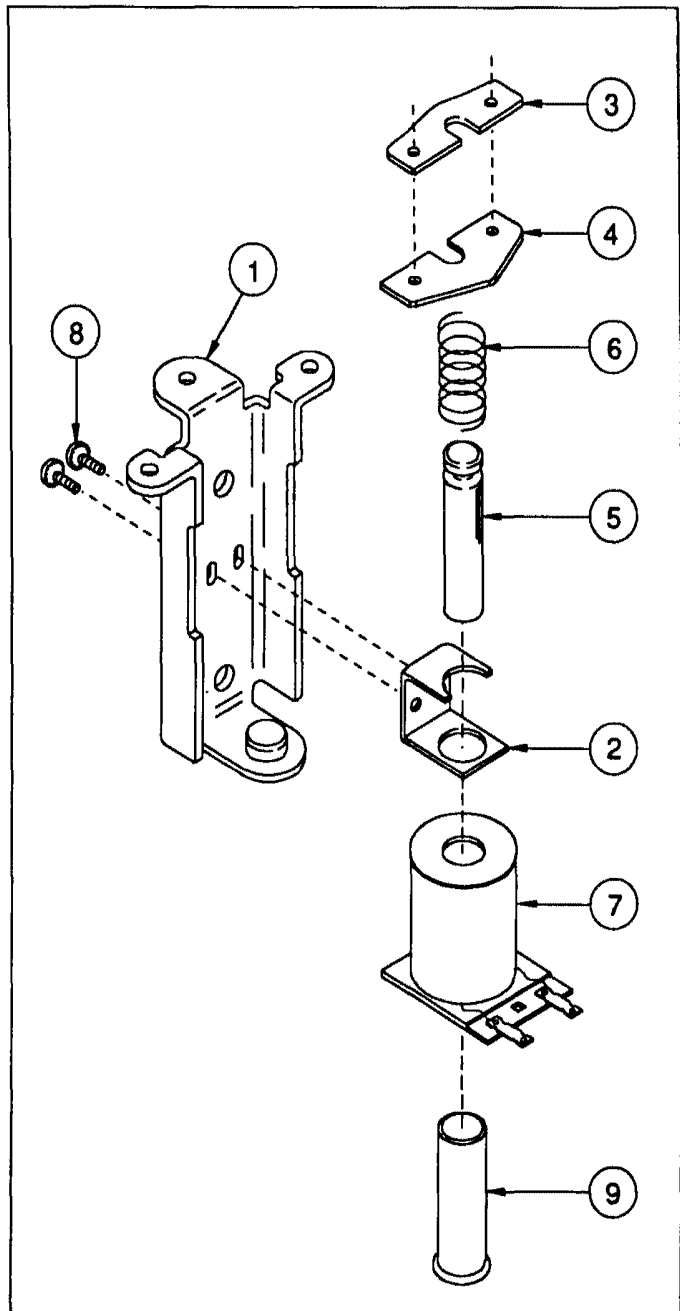

Item	Part Number	Description
1.	A-4754	Bumper Ring Assembly
2.	03-6009-A5	Bumper Base, White
3.	03-6035-5	Bumper Wafer, White
4.	03-7443-5	Bumper Body, White
5.	10-7	Spring
6.	24-8776	Socket - Wedge Base
7.	24-8768	Bulb #555 (6.3V., 0.25A.)

■ Associated Parts:

8.	03-9007-12	Jet Bumper Cap (Starburst, Raised) 2 Used
----	------------	--

Item	Part Number	Description
1.	B-7417	Bracket & Stop Assembly
2.	01-1747	Coil Retaining Bracket
3.	01-5492	Armature Link, Steel
4.	01-5493	Armature Link, Bakelite
5.	02-3406-1	Coil Plunger
6.	10-326	Armature Spring
7.	AE-26-1200	Coil Assembly
8.	4006-01017-04	Mach. Screw, 6-32 x 1/4"
9.	03-7066	Coil Tubing

B-9361-R Ball Eject Assembly

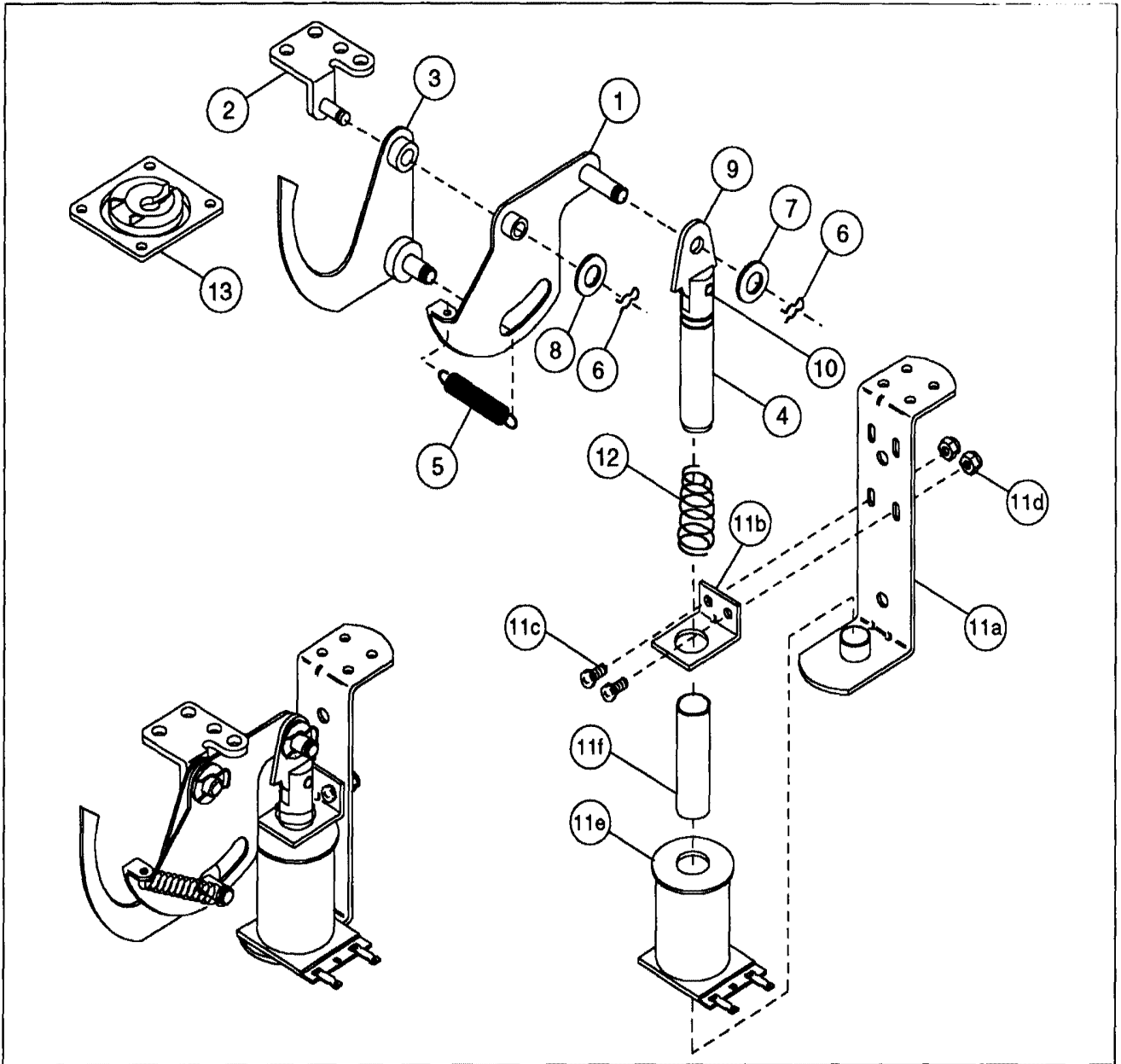

■ Associated Parts:

Item	Part Number	Description	Item	Part Number	Description
1.	A-6949-R	Spring Plate Assembly	11	A-17809	Coil & Bracket Assembly
2.	A-18146	Mounting Bracket Assembly	a)	A-17808	Bracket & Stop Assembly
3.	A-7471-R	Eject Cam Assembly	b)	01-8-508-S	Coil Retaining Bracket
4.	02-3407	Plunger Coil: 2-1/4"	c)	4006-01017-06	Mach. Screw, 6-32 x 3/8
5.	10-362	Spring - Eject	d)	4406-01119-00	Nut, 6-32 ESN
6.	12-6227	Hair Pin Clip (2)	e)	AE-26-1200	Coil Assembly
7.	4700-00030-00	Flatwasher, 17/64 x 1/2 x 15ga.	f)	03-7066	Coil Tubing
8.	4700-00103-00	Flatwasher, 17/64 x 1/2 x 28ga.	12.	10-128	Spring
9.	03-8085	Armature Link	13.	03-9101-9	Eject Shield (Tr. Red)
10.	20-8716-5	Roll Pin: 1/8 x 7/16"			

A-14525 Kicker Bracket Assembly

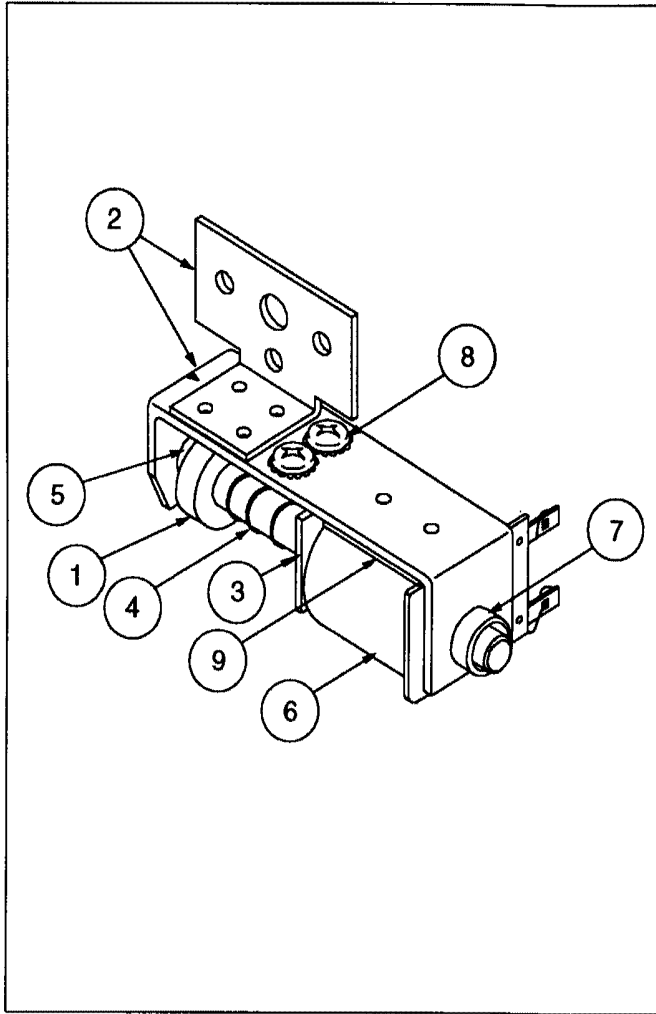

<u>Item</u>	<u>Part Number</u>	<u>Description</u>
1.	A-6306-2	Bell Armature Assembly
2.	A-14526	Mtg. Bracket Assembly
3.	01-8-508-T	Solenoid Bracket
4.	10-135	Solenoid Spring
5.	23-6420	Rubber Grommet
6.	AE-23-800	Coil Assembly
7.	03-7067-5	Coil Tubing
8.	4008-01017-04	Mach. Screw, #8-32 x 1/4"P-RH
9.	03-8523	Insulator

B-10686-1 Knocker Assembly

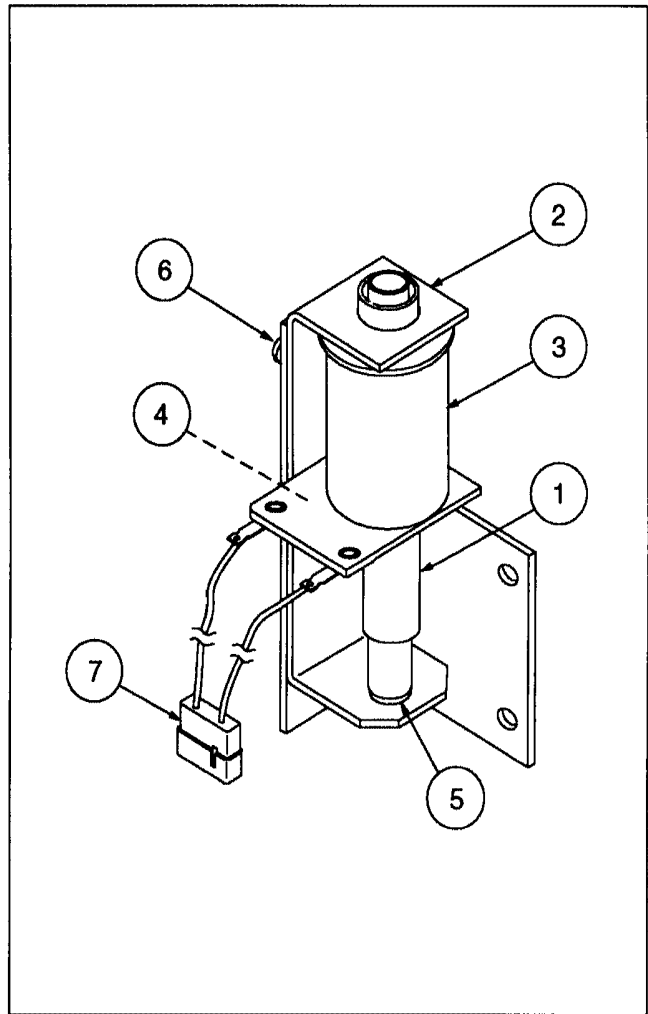

<u>Item</u>	<u>Part Number</u>	<u>Description</u>
1.	A-5387	Coil Plunger Assembly
2.	01-11273	Mtg. Bracket Assembly
3.	AE-23-800	Coil Sub-Assembly
4.	01-8-508-T	Coil Retaining Bracket
5.	23-6420	Rubber Grommet
6.	4008-01017-04	Mach. Screw, 8/32 x 1/4"P-RH
7.	H-11835	Knocker Cable
8.	03-7067-5	Coil Tubing

A-15361 Tilt Mechanism Assembly

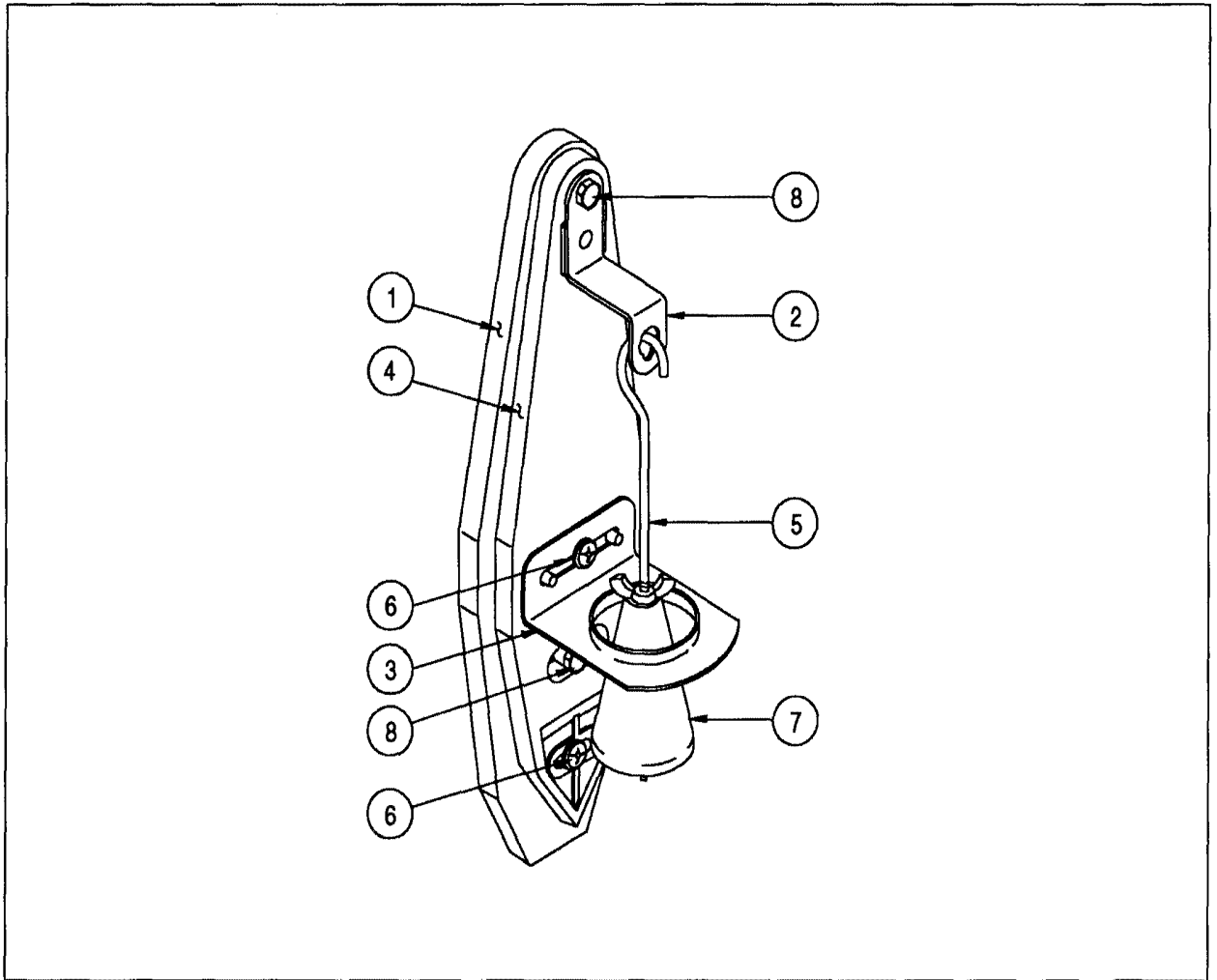

<u>Item</u>	<u>Part Number</u>	<u>Description</u>
1.	A-15360	Mount Plate, Tilt Mech.
2.	01-3444	Bracket, Tilt Upper
3.	01-3445	Bracket, Tilt Lower
4.	03-8668	Pendulum, Tilt Mech.
5.	12-6231	Wire, Plum Bob
6.	4006-01113-06	MS, 6-32 x 3/8 PL-HEX-WHD

■ Associated Parts

7.	20-6502-A	Plum Bob
8.	4406-01120-00	Wing Nut (2)

A-17829-1 Backpanel Assembly

<u>Item</u>	<u>Part Number</u>	<u>Description</u>
1.	11-831-50028-1	Back Panel - Wood
2.	A-17597	Elevator Assembly (see below for parts listing)
3.	A-16989	Cryoclaw Assembly (see page 2-26)
4.	C-13337	Single Flashlamp Assembly
5.	A-18201	Socket & #44 Bulb Assembly
6.	03-6047-2	Spacer 3/8"
7.	03-7655-4	Clamp Cable, 1/4"
8.	01-12569	Gusset Bracket
9.	4408-01118-00	Nut 8-32 Tee 3/8"
10.	4008-01113-08	Mach. Screw, 8-32 x 1/2"
11.	4808-01175-07Y	E-P #8 x 7/16
12.	4808-01175-08	E-P #8 x 1/2
13.	4106-01115-16	Sh. Metal Screw, #6 x 1"
14.	H-18086	Backpanel Cable
15.	4008-01168-12	Mach. Screw,, 8-32 x 3/4"

A-17597 Elevator Assembly

<u>Item</u>	<u>Part Number</u>	<u>Description</u>
1.	A-16909	Opto LED Assembly RTV
2.	A-16908	Opto Photo Transistor, RTV
3.	4106-01013-06	Sh. Metal Screw, #6 x 3/8"
4.	A-17582	Opto Shield & Bracket Assembly
5.	20-8712-25	"E"-Ring, .210" Shaft
6.	20-9610	Bearing - Flange
7.	03-9023	Spacer, Bearing
8.	12-6227	Hairpin Clip
9.	4700-00103-00	Flatwasher, 1/2 x 17/64 x 28ga.
10.	4008-01003-08	Mach. Screw, 8-32 x 1/2"
11.	02-4926	Elevator Guide Shaft
12.	A-17610	Drive Link Assembly
13.	4010-01169-04	Set screw, 10-32 x 1/4"
14.	A-17335	Drive Arm Assembly
15.	14-7993	Gearmotor
16.	A-17228	Elevator Frame
17.	01-11785	Elevator Mounting Plate
18.	4008-01003-05	Mach. Screw, 8-32 x 5/16
19.	A-17596	Opto PCB Assembly
20.	4404-01119-00	Nut 4-40 ESN
21.	4004-01003-05	Mach. Screw, 4-40 x 5/16
22.	H-16960	Crane Motor Cable
23.	H-17609-08	Opto Cable - Square

A-17597 Elevator Assembly

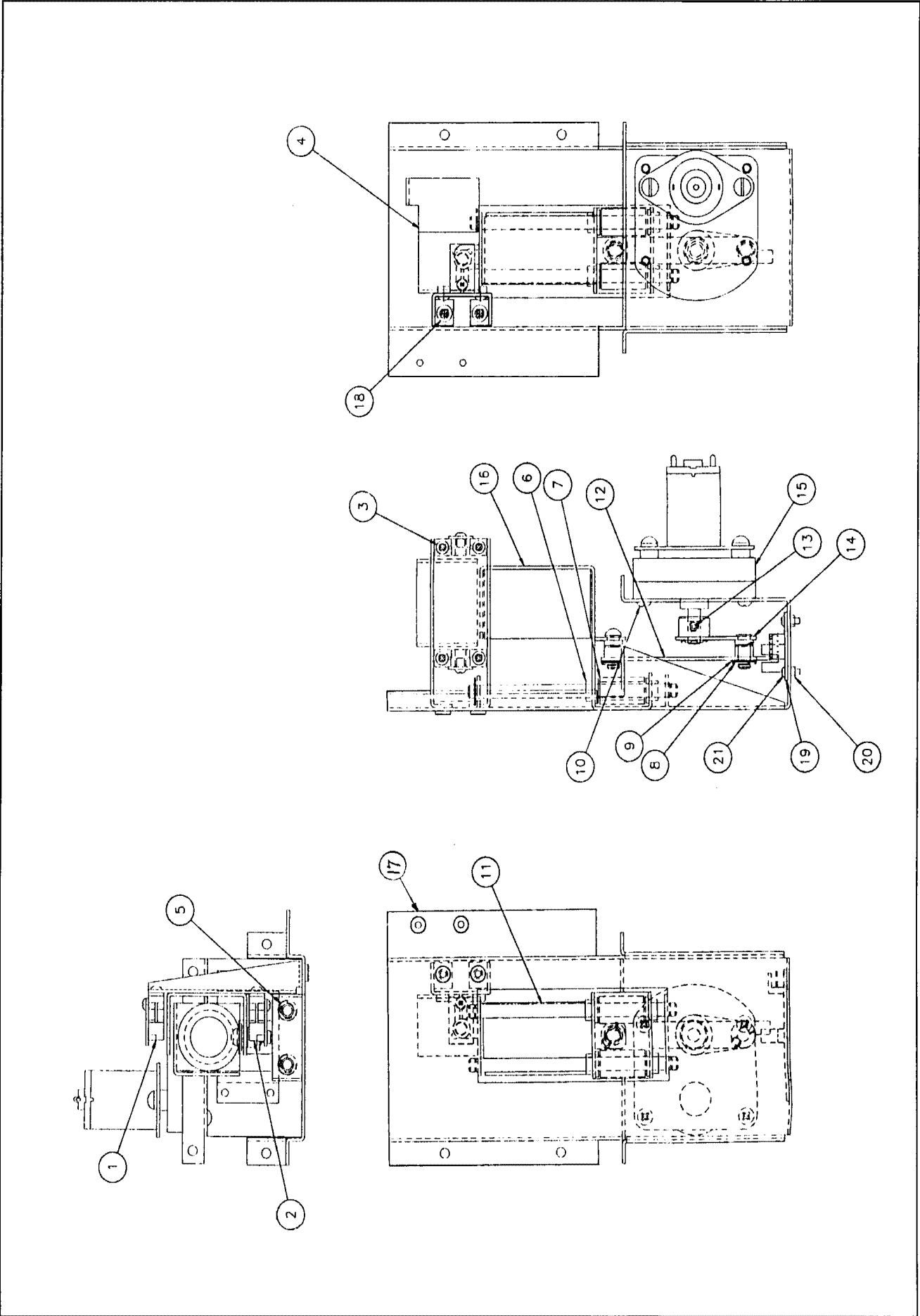

A-16989 Cryoclaw Assembly

<u>Item</u>	<u>Part Number</u>	<u>Description</u>
1.	14-7992	Gearmotor, 12VDC
2.	01-1107	Motor Mounting Bracket
3.	A-16991	Cryoclaw Actuator Assy.
4.	A-16990	Cryoclaw Support Arm Assy.
5.	4008-01003-08	Mach. Screw, 8-32 x 1/2 PH-P-HD SEMS
6.	4008-01003-05	Mach. Screw, 8-32 x 5/16 PH-P-HD SEMS
7.	4008-01003-04	Mach. Screw, 8-32 x 1/4 PH-P-HD SEMS
8.	4700-00089-00	Flatwasher, 7/16 x 11/64 x 16ga.
9.	4700-00021-00	Flatwasher, 7/16 x 13/64 x 21ga.
10.	A-16986-1	Opto PCB & Bracket Assembly
11.	SZ-33-3000	Coil
12.	01-12182	Coil Insulator
13.	4008-01076-04	Set Screw, 8-32 x 1/4 CP
14.	03-9061	Standoff - Snap In
15.	4010-01169-04	Mach. Screw, 10-32 x 1/4 SH-CP-N

A-16989 Cryoclaw Assembly

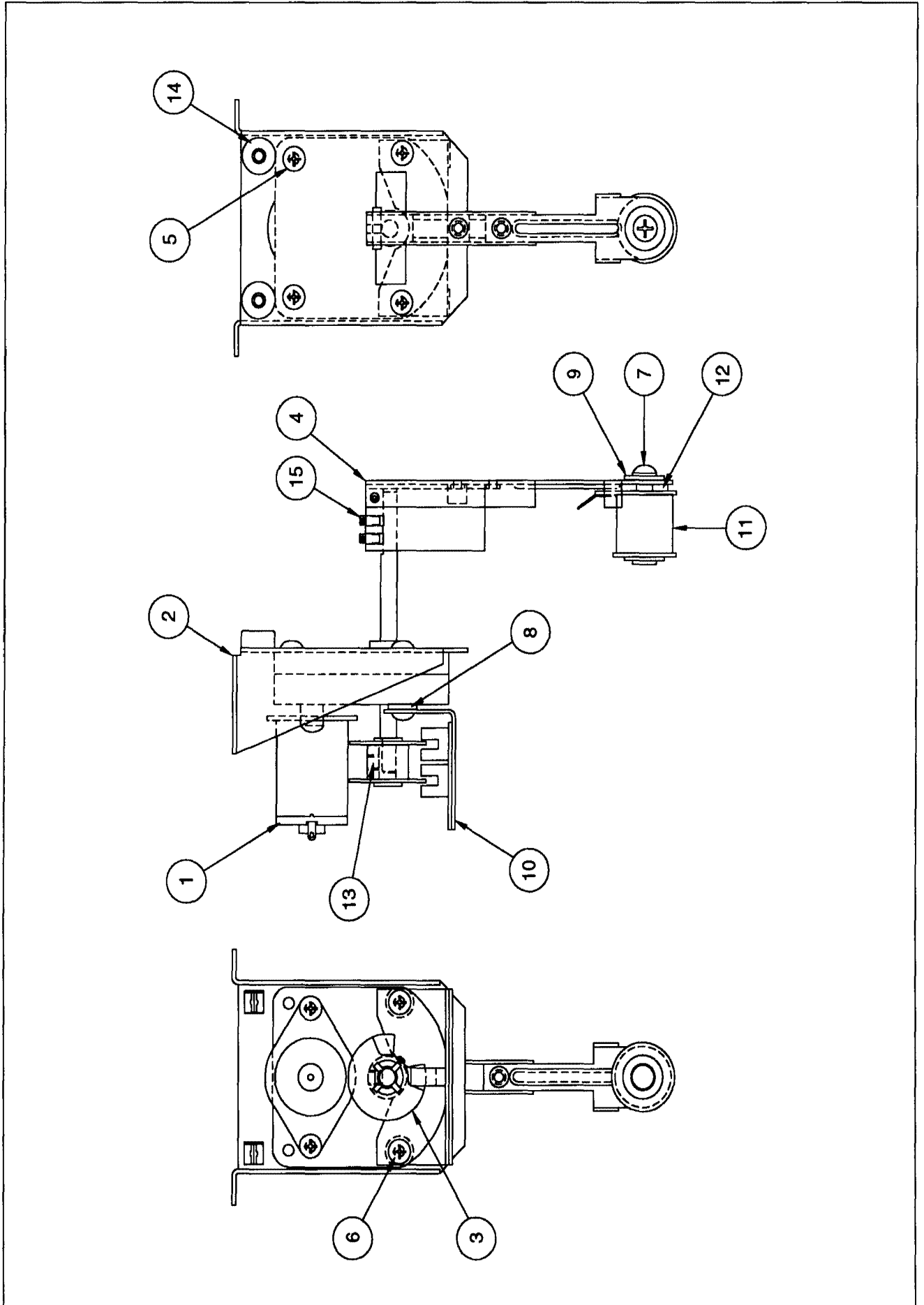

A-18016-1

Control Handle Assembly - Right

<u>Item</u>	<u>Part Number</u>	<u>Description</u>
1.	21-6702-1	Control Handle - Right
2.	21-6703-1	Control Handle Cover, Right
3.	A-18001-1	Spring & Bracket-Trigger Assy.
4.	03-9015	Trigger, Control Handle
5.	A-18511	Thumb Button Switch Assembly
6.	02-4546	Fastener, Button Head
7.	4010-01097-06B	Mach. Screw, 10-32 x 3/8 T-R BH
8.	4700-00129-00B	Flatwasher, 13/64 x 15/32 x 22ga.
9.	4702-00013-00B	Lockwasher, #10 Int. Tooth-Black
10.	4702-00014-00B	Lockwasher, 1/4 Int. Tooth-Black
11.	4004-01003-06	Mach. Screw, 4-40 x 5/16 PPH-S
12.	H-18149-1	Handle Bar Switch Cable

A-18016-2

Control Handle Assembly - Left

<u>Item</u>	<u>Part Number</u>	<u>Description</u>
1.	21-6702-1	Control Handle - Left
2.	21-6703-1	Control Handle Cover, Left
3.	A-18001-2	Spring & Bracket-Trigger Assy.
4.	03-9015	Trigger, Control Handle
5.	A-18511	Thumb Button Switch Assembly
6.	02-4546	Fastener, Button Head
7.	4010-01097-06B	Mach. Screw, 10-32 x 3/8 T-R BH
8.	4700-00129-00B	Flatwasher, 13/64 x 15/32 x 22ga.
9.	4702-00013-00B	Lockwasher, #10 Int. Tooth-Black
10.	4702-00014-00B	Lockwasher, 1/4 Int. Tooth-Black
11.	4004-01003-06	Mach. Screw, 4-40 x 5/16 PPH-S
12.	H-18149-1	Handle Bar Switch Cable

Control Handle Assembly

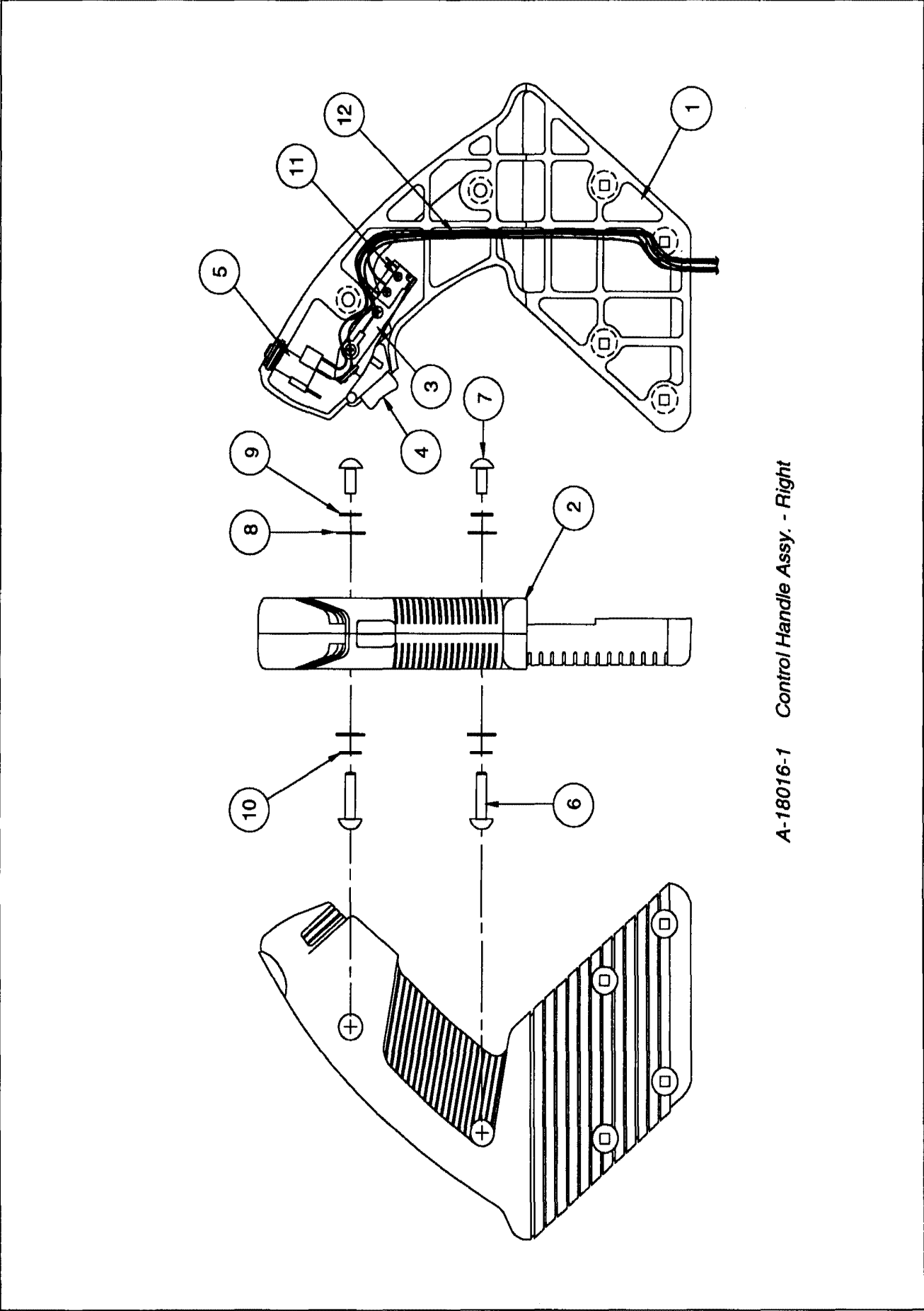

A-18016-1 Control Handle Assy. - Right

A-17215 Ball Popper Assembly - Rear

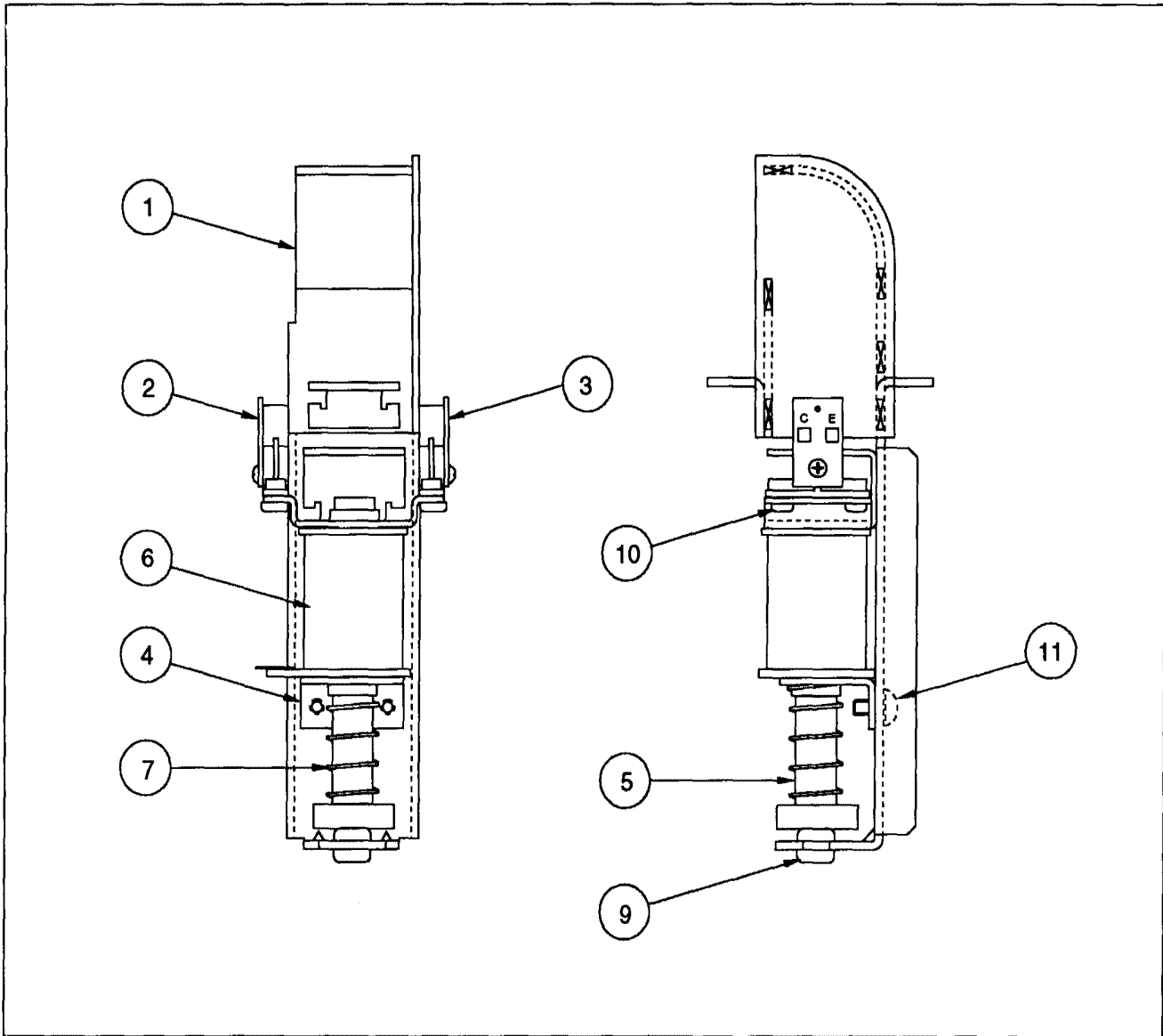

<u>Item</u>	<u>Part Number</u>	<u>Description</u>
1.	A-17765	Ball Popper Assembly
2.	A-16908	Opto LED Assembly, RTV
3.	A-16909	Opto Photo Transistor Assy., RTV
4.	01-9794	Coil Bracket
5.	A-17767	Bell Armature Assembly
6.	AE-28-1500	Coil Assembly
7.	10-135	Solenoid Spring
8.	03-7067	Coil Tubing
9.	23-6420	Rubber Grommet
10.	4106-01013-06	Sh. Metal Screw, 6-32 x 3/8 PPH-25
11.	4008-01003-04	Mach. Screw, 8-32 x 1/4 PPH-S

A-17241 Ramp Diverter Assembly

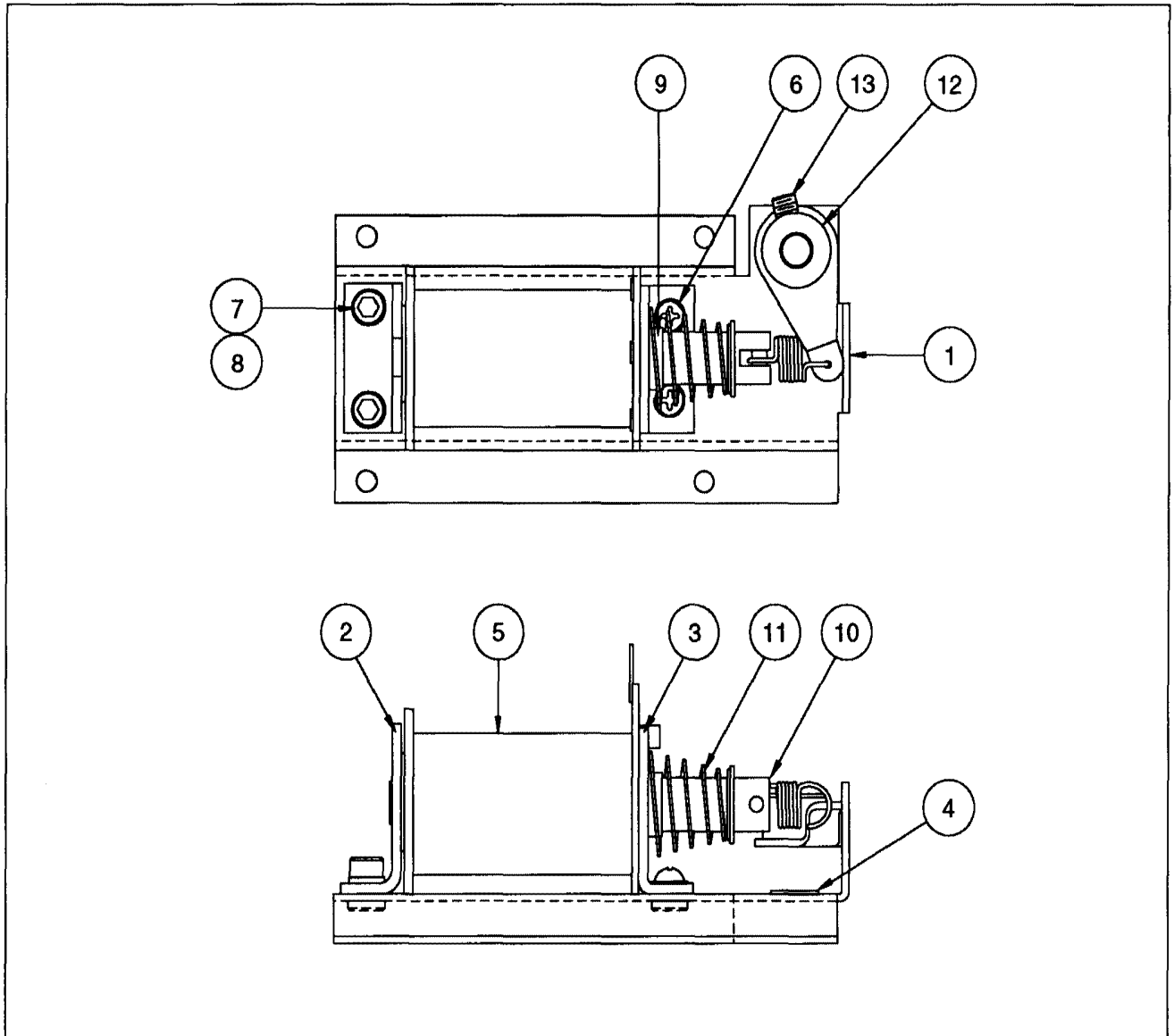

Item **Part Number** **Description**

- | | | |
|-----|---------------|------------------------------------|
| 1. | 01-11957 | Mounting Bracket |
| 2. | A-10821 | Flipper Stop Bracket |
| 3. | 01-7695 | Solenoid Bracket |
| 4. | 20-8790 | Nyliner Bearing |
| 5. | FL-11753-1 | Flipper Coil Assembly, Yellow |
| 6. | 4006-01017-04 | Mach. Screw, 6-32 x 1/4 P-RHD SEMS |
| 7. | 4010-01066-06 | Mach. Screw, 10-32 x 3/8 SHD CAP |
| 8. | 4701-0004-00 | Lockwasher #10 Split |
| 9. | 03-7066-5 | Coil Tubing |
| 10. | A-16636 | Diverter Plunger Assembly |
| 11. | 10-303 | Spring |
| 12. | A-14185 | Drive Arm Assembly |
| 13. | 4010-01169-04 | Set Screw, 10-32 x 1/4 SH CP-IN |

■ **Associated Parts:**

- | <u>Part Number</u> | <u>Description</u> |
|--------------------|------------------------------|
| A-18242 | Ball Guide Diverter Assembly |

A-17620 Chute Assembly

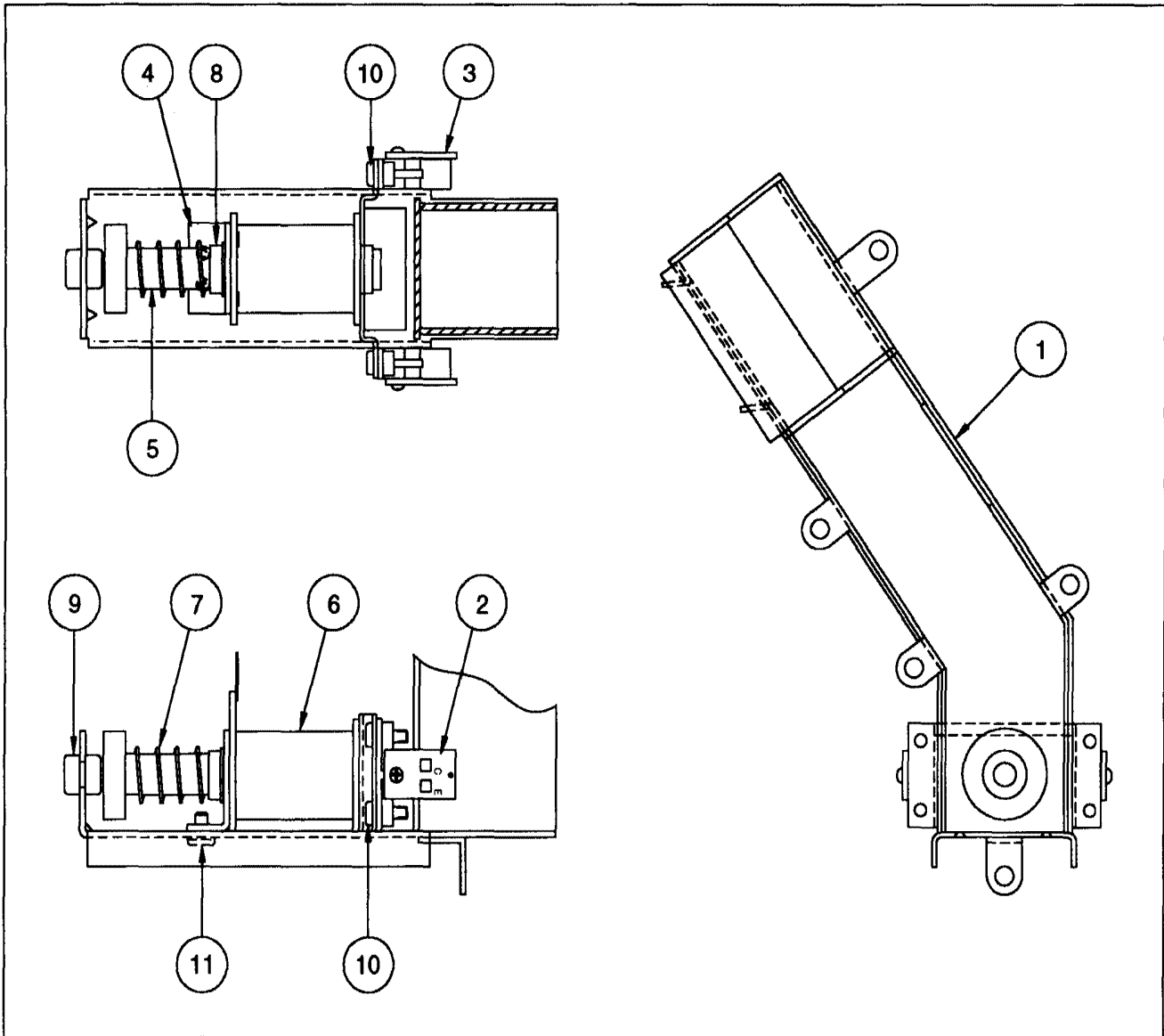

Item	Part Number	Description
1.	A-17621	Chute Assembly
2.	A-16908	Opto LED Assembly, RTV
3.	A-16909	Opto Photo Transistor Assy., RTV
4.	01-9794	Coil Bracket
5.	A-17767	Bell Armature Assembly
6.	AE-23-800	Coil Assembly
7.	10-135	Solenoid Spring
8.	03-7067	Coil Tubing
9.	23-6420	Rubber Grommet
10.	4106-01013-06	Sh. Metal Screw, 6-32 x 3/8 PPH-25
11.	4008-01003-04	Mach. Screw, 8-32 x 1/4 PPH-S

A-17540 Universal Power Interface Assembly

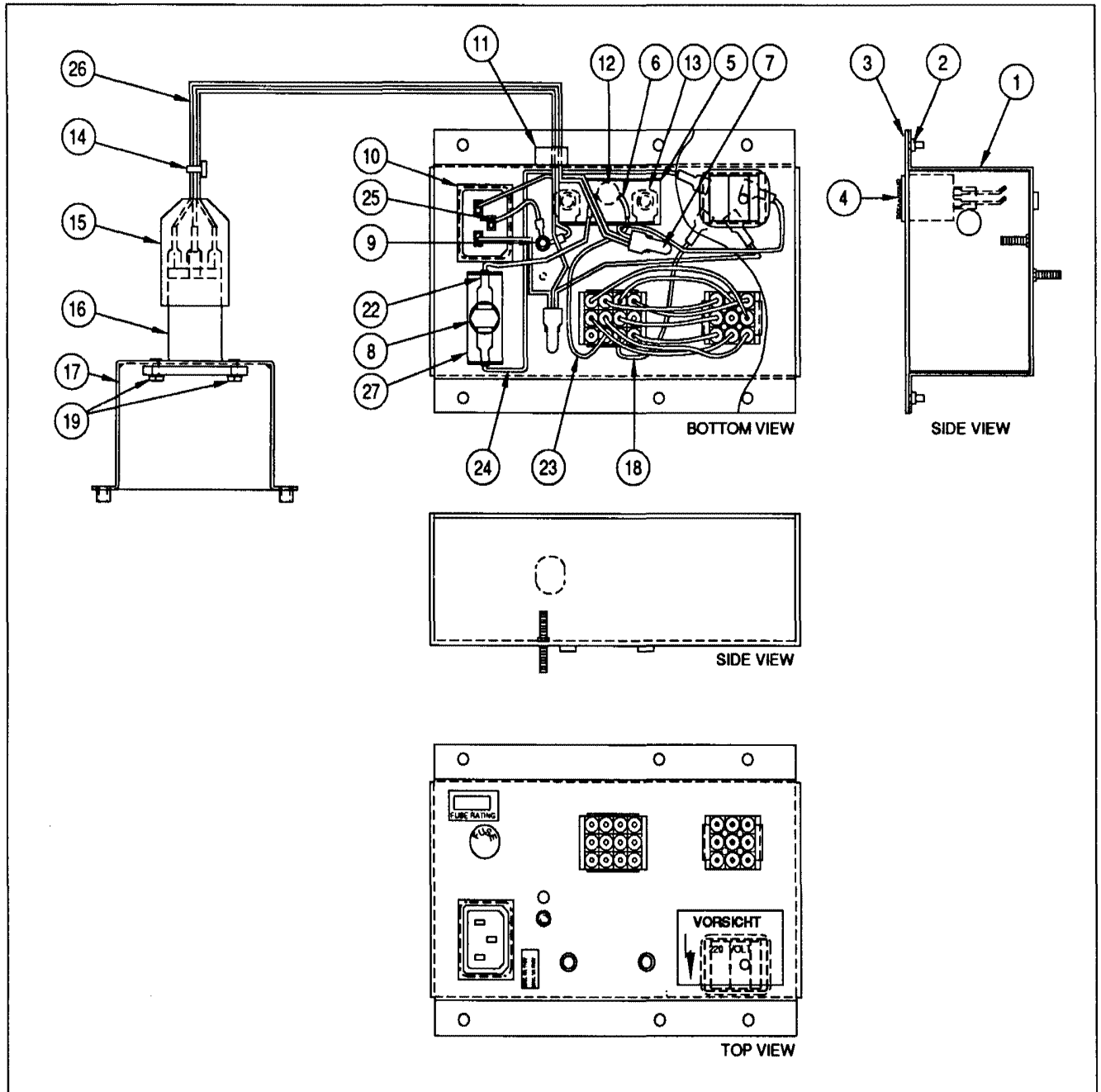

Item	Part Number	Description	Item	Part Number	Description
1.	01-12293	Power Control Chassis Box	15.	20-9682-1	Boot w/9-32 Dia. Hole
2.	4406-01128-00	Nut #6-32 KEPS	16.	5102-13864-00	Line Filter w/IEC Connector
3.	01-12294	Switch Mounting Plate Assy.	17.	01-12292	Line Filter Chassis Box
4.	5642-13935-00	Power Switch	18.	H-17992	Jumper Cable Neutral Sw/1FC
5.	01-12299	Insulator, Terminal Strip	19.	4004-01003-05	Mach. Screw, #4-40 x 5/16 P-PH-S
6.	RM-21-06	#18 Vinyl Fgls	20.	H-18050	Jumper Cable, Transformer Prog.
7.	5822-13865-00	Terminal Strip 3-CKT 2-Mtg.	21.	16-9667	Label Convenience Rcpt. Rating
8.	5733-12869-00	Fuse Holder Panel	22.	H-17543	Hot Jumper Black Cable
9.	4408-01128-00	Nut #8-32 KEPS	23.	H-17546	Jumper Interface Hot Black Cable
10.	5851-13867-00	Outlet-IEC Conn. 237 Socket	24.	H-17545	Jumper Switch/Fuse Black Cable
11.	03-8712	Strain Relief Bushing	25.	H-17542	Ground Jumper
12.	5016-12978-00	Thermistor 8A., 2.5R25	26.	5797-13940-01	Jumper Cable
13.	4008-01017-10	Mach. Screw, 8-32 x 5/8 P-PH-S	27.	01-10623	Insulator, Thermistor
14.	03-7520-3	Ty-Wrap Nylon			

Target Assemblies

Playfield Targets

Part Number	Description	Quantity
A-17795-6	Stationary Target Assembly (Yellow)	3
A-17799-6	Stationary Target Assembly (Opaque Yellow)	2
A-18018-4	Stationary Target Assembly (Opaque Red)	2

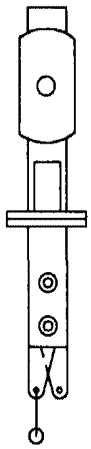

A-17795-6

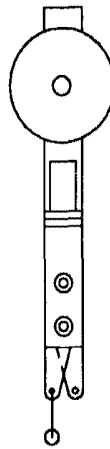
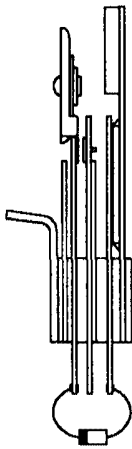

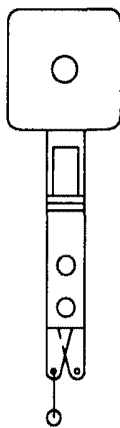
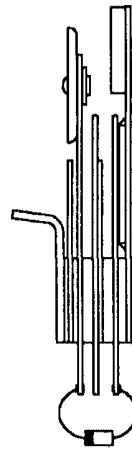

A-17799-6

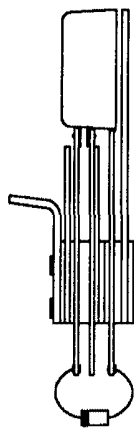

A-18018-4

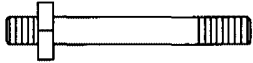
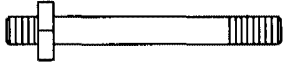
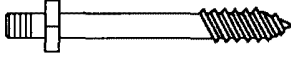
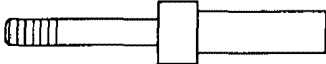
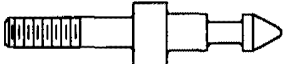
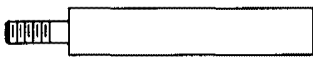
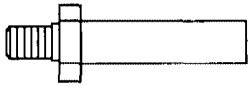
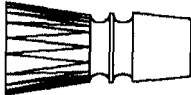
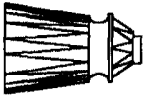

Posts

	Part Number	Description	Quantity
	02-4020	Support Post	4
	02-4424-1	Post: 6-32/8-32 2-1/32"	9
	02-4425-1	Post: 8-32/ #8-32 2-3/8"	3
	02-4426-1	Post: #6-32 /8 1-29/32"	3
	02-4659-1	Mini Post: 6-32 x 3/8"	16
	02-4660	Single Bumper Post	3
	02-4765-9	Mounting Post: 4.62"	3
	02-4765-10	Mounting Post: 2.0"	2
	02-4842	Bumper Post	1
	03-8130-13	Double Bumper Post, Starred (Crystal Clear)	1
	03-8319-9	Star Post #8	18
	03-8365-10	Post: 3/8 x 1-3/16" (Tr. Blue)	14

Unique Parts

	Part Number	Description
Unique Backbox Parts	A-16917-50028	Sound Board Assembly
	A-18085	Backbox & Decal Assembly
	A-8552-50028	Backglass Assembly
Unique Cabinet Parts	A-18106-1	Control Handle Assembly, Right
	A-18106-2	Control Handle Assembly, Left
	A-17540	Universal Power Interface Assembly
	A-18142-1	Control Handle Plate Assembly, Right
	A-18142-2	Control Handle Plate Assembly, Left
	01-12328-1	Backbox Mounting Bracket, Left
	01-12328-2	Backbox Mounting Bracket, Right
	11-1171	Wood Cabinet
	5610-13953-00	WPC Transformer 94
	Unique Playfield Parts	A-12030-3
A-13204-50028		Bottom Arch Assembly
A-13769-50028		Playfield & Insert Assembly
A-16765-1		Ball Trough Assembly
A-17166-1		Flipper Ball Guide Assembly, Right
A-17166-2		Flipper Ball Guide Assembly, Left
A-17215		Ball Popper-Rear Assembly
A-17233-33		Envelope Assembly
A-17241		Ramp Diverter Assembly
A-17242		Diverter Ball Guide Assembly
A-17291		Inclined Ramp Assembly
A-17410		Car Catapult Assembly
A-17620		Chute & Ball Popper Assembly
A-17644		Opto Car Tunnel Assembly
A-17771		Feed Ramp Assembly
A-17784		Diverter Ramp Assembly
A-17785		Ramp Assembly, #2
A-17786		Ramp Assembly, #3
A-17792-1		5-Ball Cashbox Assembly, Multiple
A-17823		Ball Popper Assembly
A-17829		Backpanel Assembly
A-17898-1		6-Lamp PCB & Spacer Assembly
A-17899-1		25-Lamp PCB & Spacer Assembly
A-17902-1		5-Lamp PCB & Spacer Assembly
A-17916-1		6-Lamp PCB & Spacer Assembly
A-18018-4		Stationary Target, Square (Red)

Unique Parts (Continued)

Unique Playfield Parts

Part Number	Description
A-18038	Speaker/Display Panel Assembly
A-18057	Cryo-Bracket Assembly
A-18126	Wasteland PCB Assembly
A-18132	Switch & Bracket Assembly
A-18242	Diverter Ball Guide Assembly
A-18245	Car & Bracket Assembly
A-18229	Ball Guide
01-11925	Bracket Captive Car Stop
01-12204	Ball Guide #2
01-12205	Ball Guide #3
01-12206	Ball Guide #4
01-12207	Ball Guide #5
01-12208	Ball Guide #6
01-12209	Ball Guide #7
01-12210	Ball Guide #8
01-12289	Ball Guide Arch - Right
01-12290	Ball Guide Arch - Left
01-12323	Ball Guide #9
01-12569	Gusset Back Panel Bracket
02-4765-9	Mounting Post 4.62
03-9000	Car Tunnel
03-9007-12	Jet Bumper Cap, Starburst (Tr. Orange)
03-9042	Cryoclaw Base
03-9043-1	Wall - Rear Left
03-9043-2	Wall -Rear Right
03-9044	Cryoclaw Arm
03-9101-9	Eject Shield (Tr. Red)
11-1158A	Wood Rail: 1/2 x 1-1/8 x 9-1/2"
11-1158-B	Wood Rail: 1/2 x 1-1/8 x 25-1/8"
11-1158-C	Wood Rail: 1/2 x 1-1/8 x 33-3/8"
11-1158-D	Wood Rail: 1/2 x 1-1/8 x 38-1/8"
12-7134	Wire Ramp #1
12-7135	Wire Ramp #2
12-7136	Wire Ramp #3
12-7166	Cryo Ramp-Single Ramp
12-7171	Ball Popper Wire Cage
12-7181	Cryoclaw Wire Drain
12-7182	Cryo Ramp-Double Wire
20-9928	Olds 442 Car
20-9935	Eyeball
31-1927-50028	Bottom Arch
36-50028	Playfield Hardcoat

Cables

	Part Number	Description
Backbox Cables	H-14584	Dot Matrix Display Power Cable
	H-15476	Logic Power Cable
	H-15736	Secondary Cable
	H-16505-1	Extended Driver Cable
	H-17926	Insert Cable
Playfield Cables	H-17921-1	Playfield Switch Cable
	H-17922-2	Playfield Lamp Cable
	H-17923	Playfield Solenoid Cable
	H-17924	Playfield Lamp Cable
Cabinet Cables	H-16599	Coin Door Cable DBV
	H-17005-2	Cabinet Cable
	H-17019	Dixie-Mars Interconnect
	H-17217	Plumb Bob/Mech. Protect Cable
	H-17837-2	Voltage Program Cable
	H-17925	Cabinet Switch Cable

UPPER PLAYFIELD PARTS LOCATIONS

Item	Part Number	Description
1	A-14525	Kicker Bracket Assembly
2	A-16765	Ball Trough Assembly
3	01-12289	Ball Guide Arch-Right
4	A-17166-1	Flipper Ball Guide
5	A-17811	Nylon Kicker
5a)	A-17809	Coil & Bracket
6	12-7134	Wire Ramp #1
7	A-17291	Incline Ramp
8	A-18017-6	Standup Target
9	12-7171	Wire Cage
10	A-17620	Chute & Ball Popper
11	A-18019-6	Standup Target
12	01-12207	Ball Guide #5
13	01-12209	Ball Guide #7
14	A-17785	Ramp #2
15	A-17811	Nylon Kicker
15a)	A-17809	Coil & Bracket
16	12-6466-18	Ball Guide Wireform
17	A-17784	Diverter Ramp
18	B-9414	Jet Bumper Assembly
18a)	A-9415-2	Jet Bumper Coil Assembly
18b)	A-12030-2	Jet Bumper Switch Assembly
19	A-17241	Ramp Diverter
19a)	A-18242	Diverter Ball Guide
20	A-18017-6	Standup Target
21	A-17786	Ramp #3
22	A-17215	Rear Ball Popper
23	12-7166	Single Wire Ramp
24	A-17771	Feed Ramp
25	12-7181	Drain & Wireform
26	A-17597	Elevator Assembly
27	A-16989	Cryoclaw Assembly
28	12-7182	Double Wire Ramp
29	A-18018-4	Standup Target
30	A-17644	Opto Car Tunnel Assembly
30a)	03-9000	Car Tunnel
31	01-12323	Ball Guide #9
32	A-17410	Car Catapult
33	20-9250-5	Flipper Shaft & Paddle
33a)	23-6519-4	Red Rubber Ring
33b)	FL-11630	Flipper Coil
34	01-12206	Ball Guide #4
35	A-18018-4	Standup Target
36	A-18017-6	Standup Target
37	B-9361-R	Ball Eject Assembly
37a)	A-17809	Coil & Bracket
38	12-7135	Wire Ramp #2
39	01-12204	Ball Guide #2
40	01-12205	Ball Guide #3
41	12-7136	Wire Ramp #3
42	A-17811	Nylon Kicker
42a)	A-17809-1	Coil & Bracket
43	A-17166-2	Flipper Ball Guide
44	20-9250-5	Flipper Paddle & Shaft
44a)	23-6519-4	Red Rubber Ring
44b)	FL-17629	Flipper Coil
45	01-12290	Ball Guide Arch-Left

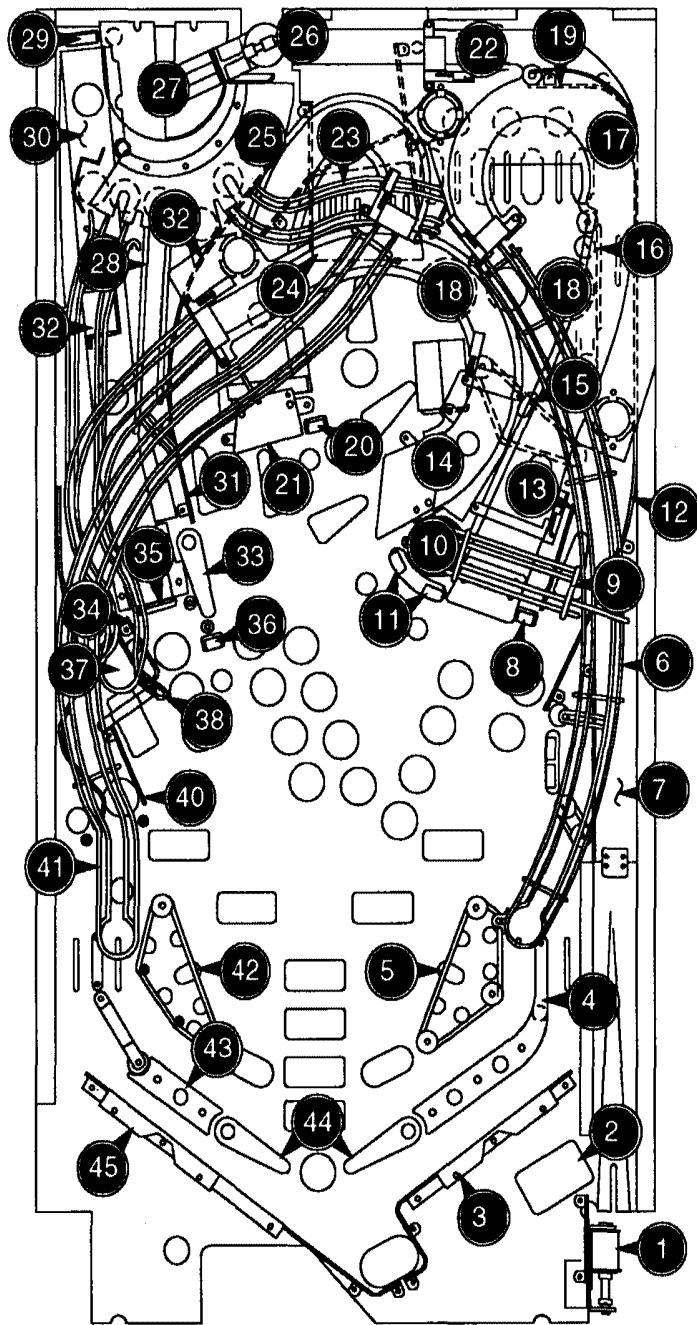

*The DEMOLITION MAN hardcoat playfield does not require a full mylar. However Mylars can be purchased through your local Williams Distributor.

Not Shown

Part Number	Description
A-18016-1	Control Handle-Right
A-18016-2	Control Handle-Left
03-9118-1	*Full Playfield Mylar
16-50028-1	Instruction Card
20-6500	Steel Ball
20-9928	Olds 442 Car
20-9929	Ultralite Police Car
20-9935	Eyeball

Parts Under Bottom Arch

A-13204-50028	Bottom Arch Assembly
31-1927-50028	Screened Bottom Arch
12-7168	Wire Fence
20-9041	Tinnerman Speednut
20-9601	#8-32 Nut Retainer

LOWER PLAYFIELD PARTS LOCATIONS

Item	Part Number	Description
1.	01-9211	Plfd. Hanger Bracket (2 Used)
2.	A-16765	Outhole Ball Trough Assembly
3.	A-15849-R-2	Flipper Assembly, Lower Right
4.	01-11781	Leg Support (2 Used)
5.	A-17811	Kicker Arm (Slingshot) Assy., Right
	A-17809	Coil & Bracket Assembly
	10-128	Spring
6.	A-17898	6-Lamp PCB Assembly
7.	A-17899	25-Lamp PCB Assembly
8.	A-17620	Chute & Ball Popper Assembly
9.	A-16989	Cryoclaw Assembly
10.	A-17811	Kicker Assembly
	A-17809	Coil & Bracket Assembly
11.	A-9415-2	Jet Bumper Coil Assembly
12.	A-17749-2	Plfd. Slide Mechanism, Right
13.	A-17902	5-Lamp G.I. PCB Assembly
14.	A-17624	3-Lamp Board Assembly
15.	A-15542	Motor EMI Assembly
16.	A-17421	Ramp Diverter Assembly
17.	A-17215	Ball Popper Assembly - Rear
18.	A-16120	DC Motor Control Assembly
19.	A-17749-1	Plfd. Slide Mechanism, Left
20.	A-17823	Ball Popper Trough Assembly
21.	A-17916	5-Lamp PCB Assembly
22.	A-14876-L	Flipper Assembly, Upper Left
23.	B-9361-R	Ball Eject Assembly
	A-17809	Coil & Bracket Assembly
24.	A-17811	Kicker Arm (Slingshot) Assy., Left
	A-17809-1	Coil & Bracket Assembly
	10-128	Spring
25.	A-15576	7-Switch Opto PCB Assembly
26.	A-15849-L-2	Flipper Assembly, Lower Left
27.	A-14525	Kicker Bracket Assembly

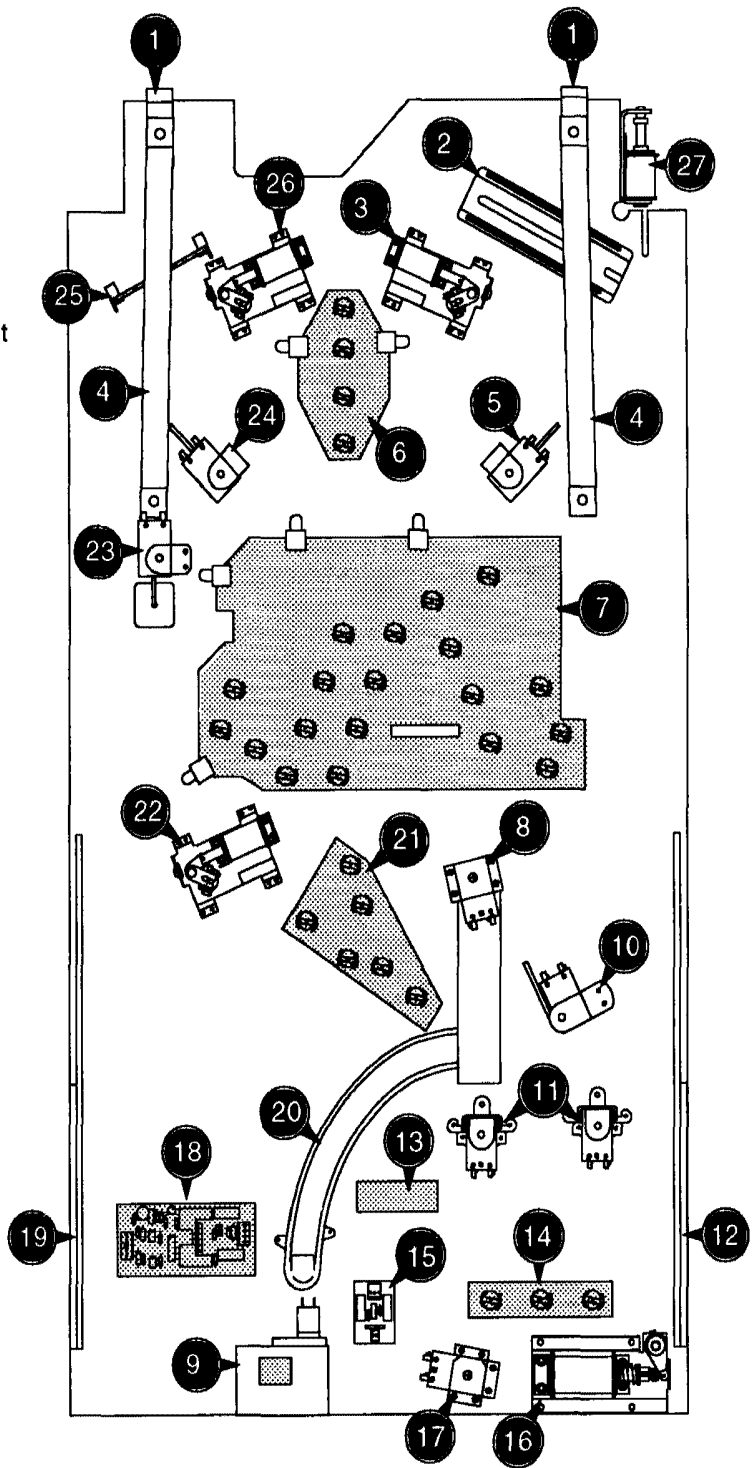

Underside of Playfield, Viewed in Raised Position

RUBBER RINGS

Item	Part No.	Qty	Description
A	23-6535	1	Black Rubber Bumper Grommet
B	23-6556	17	Black Rubber Bumper Sleeve
C	23-6641	9	Black Rubber Bumper
D	23-6694-8	1	Black Rubber Ring, 1-1/2"
E	23-6694-9	1	Black Rubber Ring, 2"
F	23-6694-3	6	Black Rubber Ring, 5/16"
G	23-6694-5	1	Black Rubber Ring, 3/4"
H	23-6694-11	3	Black Rubber Ring, 3"

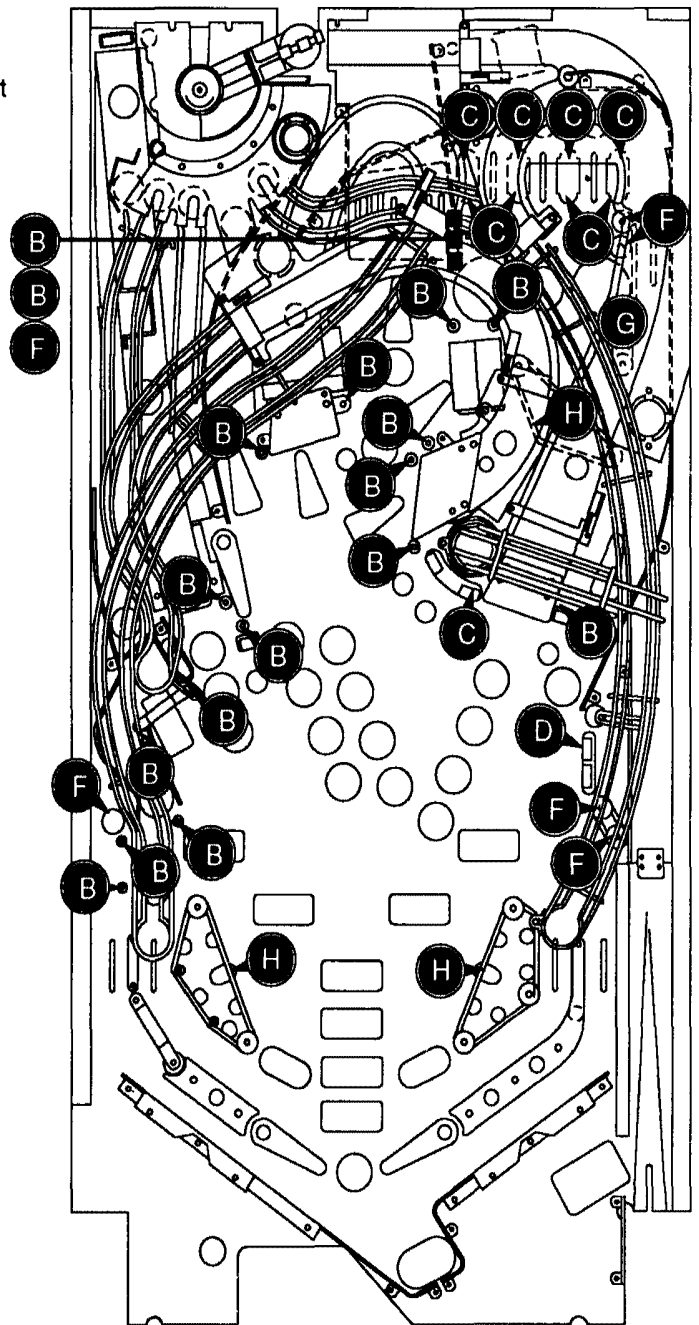

LAMPS

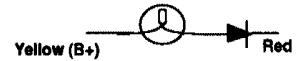

Column Row	1 Yellow-Brown J137-1 Q98	2 Yellow-Red J137-2 Q97	3 Yellow-Orange J137-3 Q96	4 Yellow-Black J137-4 Q95	5 Yellow-Green J137-5 Q94	6 Yellow-Blue J137-6 Q93	7 Yellow-Violet J137-7 Q92	8 Yellow-Gray J137-9 Q91
1 Red-Brown J133-1 Q90	Ball Save 11	Right Ramp Jackpot 21	Right Loop Jackpot 31	Right Ramp Explode 41	Underground Arrow 51	Claw "Capture Simon" 61	"Super Jackpot" 71	Center Ramp Middle 81
2 Red-Black J133-2 Q89	Fortress Multiball 12	Right Loop Explode 22	Standup 5 32	Right Ramp Car Chase 42	Underground Jackpot 52	Claw "Sup. Jets" 62	"Computer" 72	Center Ramp Outer 82
3 Red-Orange J133-4 Q88	Museum Multiball 13	Light Quick Freeze 23	Right Ramp Arrow 33	Quick Freeze 43	Standup 2 53	Claw "Prison Break" 63	"Demo Time" 73	Center Ramp Inner 83
4 Red-Yellow J133-5 Q87	Cryoprison Multiball 14	Freeze 4 24	Left Ramp Jackpot 34	Left Ramp Car Chase 44	Left Ramp Arrow 54	Claw "Freeze" 64	Not Used 74	Center Ramp Arrow 84
5 Red-Green J133-6 Q86	Wasteland Multiball 15	Claw Ready 25	Left Loop Jackpot 35	Extra Ball 45	Side Ramp Jackpot 55	Claw "ACMAG" 65	Not Used 75	Right Loop Arrow 85
6 Red-Blue J133-7 Q85	Shoot Again 16	Freeze 3 26	Car Crash Top 36	Start Multiball 46	Side Ramp Arrow 56	Middle Rollover 66	Standup 4 76	Buy-In Button 86
7 Red-Violet J133-8 Q84	Access Claw 17	Freeze 2 27	Standup 1 37	Car Crash Bottom 47	Left Loop Arrow 57	Top Rollover 67	Standup 3 77	Ball Launch 87
8 Red-Gray J133-9 Q83	Left Ramp Explode 18	Freeze 1 28	Car Crash Center 38	Left Loop Explode 48	Center Ramp Jackpot 58	Lower Rollover 68	Retina Scan 78	Start Button 88

LAMPS LOCATIONS

Item	Bulb No.	Lamp Assy No.	Description
11	24-8768	A-17898	Ball Save #555
12	24-8768	A-17898	Fortress Multiball #555
13	24-8768	A-17898	Museum Multiball #555
14	24-8768	A-17898	Cryoprison Multiball #555
15	24-8768	A-17898	Wasteland Multiball #555
16	24-6549	A-17807	Shoot Again #44
17	24-6549	A-17807	Access Claw #44
18	24-8768	A-17899	Left Ramp Explode #555
21	24-8768	A-17899	Right Ramp Jackpot #555
22	24-8768	A-17899	Right Loop Explode #555
23	24-8768	A-17899	Light Quick Freeze #555
24	24-8768	A-17899	Freeze 4 #555
25	24-8768	A-17899	Claw Ready #555
26	24-8768	A-17899	Freeze 3 #555
27	24-8768	A-17899	Freeze 2 #555
28	24-8768	A-17899	Freeze 1 #555
31	24-8768	A-17899	Right Loop Jackpot #555
32	24-8768	A-17899	Standup 5 #555
33	24-8768	A-17899	Right Ramp Arrow #555
34	24-8768	A-17899	Left Ramp Jackpot #555
35	24-8768	A-17899	Left Loop Jackpot #555
36	24-8768	A-17899	Car Crash Top #555
37	24-8768	A-17899	Standup 1 #555
38	24-8768	A-17899	Car Crash Center #555
41	24-8768	A-17899	Right Ramp Explode #555
42	24-8768	A-17899	Right Ramp Car Chase #555
43	24-8768	A-17899	Quick Freeze #555
44	24-8768	A-17899	Left Ramp Car Chase #555
45	24-8768	A-17899	Extra Ball #555
46	24-8768	A-17899	Start Multiball #555
47	24-8768	A-17899	Car Crash Bottom #555
48	24-8768	A-17899	Left Loop Explode #555
51	24-8768	A-17916	Underground Arrow #555
52	24-8768	A-17916	Underground Jackpot #555
53	24-8768	A-17916	Standup 2 #555
54	24-8768	A-17916	Left Ramp Arrow #555
55	24-8768	A-17916	Side Ramp Jackpot #555
56	24-8768	A-17916	Side Ramp Arrow #555
57	24-6549	A-17835	Left Loop Arrow #44
58	24-6549	A-17807	Center Ramp Jackpot #44
61	24-8768	A-18056	Claw "Capture Simon" #555
62	24-8768	A-18056	Claw "Sup. Jets" #555
63	24-8768	A-18056	Claw "Prison. Break" #555
64	24-8768	A-18056	Claw "Freeze" #555
65	24-8768	A-18056	Claw "ACMAG" #555
66	24-8768	A-17624	"M" Rollover #555
67	24-8768	A-17624	"T" Rollover #555
68	24-8768	A-17624	"L" Rollover #555
71	24-8768		"Super Jackpot" #555
72	24-8768	A-17272	"Computer" #555
73	24-8768	A-17272	"Demo Time" #555
74			Not Used
75			Not Used
76	24-6549	A-17835	Standup 4 #44
77	24-6549	A-17835	Standup 3 #44
78	24-6549	A-17807	Retina Scan #44
81	24-8768	A-17902	Center Ramp Middle #555

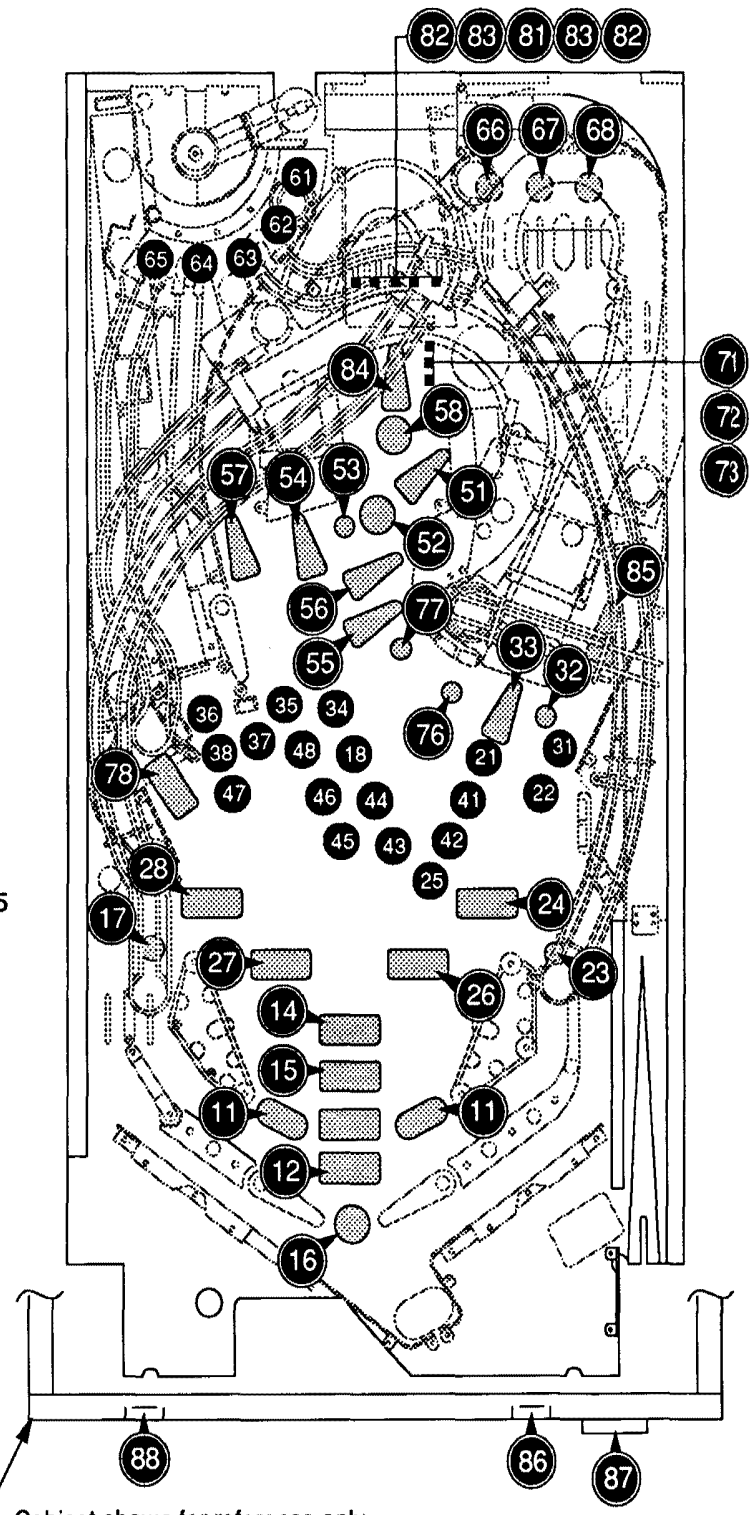

Item	Bulb No.	Lamp Assy No.	Description
82	24-8768	A-17902	Center Ramp Outer #555
83	24-8768	A-17902	Center Ramp Inner #555
84	24-6549	A-17807	Center Ramp Arrow #44
85	24-6549	A-17835	Right Loop Arrow #44
86		20-9663-9	Buy-in Button
87		20-9663-B-4	Ball Launch
88		20-9663-2	Start Button

SWITCHES

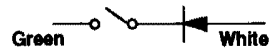

Dedicated Grounded Switches	Column		1	2	3	4	5	6	7	8	Flipper Grounded Switches
	Row		Green-Brown J207-1 U20-18	Green-Red J207-2 U20-17	Green-Orange J207-3 U20-16	Green-Yellow J207-4 U20-15	Green-Black J207-5 U20-14	Green-Blue J207-6 U20-13	Green-Violet J207-7 U20-12	Green-Gray J207-9 U20-11	
Orange-Brown J205-1 Left Coin Chute D1	White-Brown J209-1 U18-11	Bail Launch	Slam Tilt	Trough 1	Left Slingshot	Left Ramp Enter	Side Ramp Enter	Chase Car 1	Claw "Capture Simon"	Black-Green J906-1 Lower Right E.O.S. F1	
Orange-Red J205-2 Center Coin Chute D2	White-Red J209-2 U18-9	Left Handle Button	Coin Door Closed	Trough 2	Right Slingshot	Left Ramp Exit	Side Ramp Exit	Chase Car 2	Claw "Sup. Jets"	Blue-Violet J905-1 Lower Right Opto F2	
Orange-Black J205-3 Right Coin Chute D3	White-Orange J209-3 U18-5	Start Button	Buy-in Button	Trough 3	Left Jet Bumper	Center Ramp	Left Rollover	Top Popper	Claw "Prison Break"	Black-Blue J906-3 Lower Left E.O.S. F3	
Orange-Yellow J205-4 4th Coin Chute D4	White-Yellow J209-4 U18-7	Plumb Bob Tilt	Always Closed	Trough 4	Top Slingshot	Upper Rebound	Center Rollover	Elevator Hold	Claw "Freeze"	Blue-Gray J905-2 Lower Left Opto F4	
Orange-Green J205-5 Normal Function Service Credits D5	White-Green J209-5 U19-11	Left Outlane	Claw Position 1	Trough 5	Right Jet Bumper	Left Loop	Right Rollover	Elevator Ramp	Claw "ACMAG"	Black-Violet J906-4 Upper Right E.O.S.* F5	
Orange-Blue J205-7 Normal Function Volume Down D6	White-Blue J209-7 U19-9	Left Inlane	Claw Position 2	Trough Jam	Right Ramp Enter	Standup 2	Eject	Bottom Popper	Upper Left Flipper Gate	Black-Yellow J905-3 Upper Right Opto* F6	
Orange-Violet J205-8 Normal Function Volume Up D7	White-Violet J209-8 U19-5	Right Inlane	Shooter Lane	Not Used	Right Ramp Exit	Standup 3	Elevator Index	Eyeball Standup	Car Chase Standup	Black-Gray J906-5 Upper Left E.O.S. F7	
Orange-Gray J205-9 Normal Function Begin Test D8	White-Gray J209-9 U19-7	Right Outlane	Not Used	Standup 5	Right Freeway	Standup 4	Not Used	Standup 1	Lower Rebound	Black-Blue J905-5 Upper Left Opto F8	

 = Opto Switch * = Not Used

SWITCH LOCATIONS

Item	Switch No.	Where Used
F1	SW-1A-194	Lower Rt. Flipper EOS
F2	A-17316	Lower Rt. Flipper Cab.
F3	SW-1A-194	Lower Lt. Flipper EOS
F4	A-17316	Lower Lt. Flipper Cab.
F5	Not Used	Upper Rt. Flipper EOS
F6	Not Used	Upper Rt. Flipper Cab.
F7	SW-1A-193	Upper Lt. Flipper EOS
F8	A-17316	Upper Lt. Flipper Cab.
11	20-9663-B-4 (cabinet)	Ball Launch
	20-9804 (button)	
	5647-12693-11 (trigger)	
12	20-9804 (button)	Left Handle Button
	5647-12693-11 (trigger)	
13	20-9663-1	Start Button
14	20-6502-A	Plumb Bob Tilt
15	5467-12693-19	Left Outlane
16	5467-12693-19	Left Inlane
17	5467-12693-19	Right Inlane
18	5467-12693-19	Right Outlane
21	A-17238	Slam Tilt
22	5643-09268-00	Coin Door Closed
23	20-9663-9	Buy-in Button
24	5643-09112-00	Always Closed
25	A-16986	Claw Position 1
26	A-16986	Claw Position 2
27	A-16759	Shooter Lane
28	5467-12693-19	Not Used
31	A-16927 (LED)	Trough 1
	A-16926 (transistor)	
32	A-16927 (LED)	Trough 2
	A-16926 (transistor)	
33	A-16927 (LED)	Trough 3
	A-16926 (transistor)	
34	A-16927 (LED)	Trough 4
	A-16926 (transistor)	
35	A-16927 (LED)	Trough 5
	A-16926 (transistor)	
36	A-16927 (LED)	Trough Jam
	A-16926 (transistor)	
37	Not Used	Not Used
38	A-8017-6	Standup 5
41	A-17801 (count)	Left Slingshot
	SW-1A-120 (score)	
42	A-17801 (count)	Right Slingshot
	SW-1A-120 (score)	
43	A-12030-3	Left Jet Bumper
44	A-17801 (count)	Top Slingshot
	SW-1A-120 (score)	
45	A-12030-3	Right Jet Bumper
46	55647-12693-36	Right Ramp Enter
47	5647-12693-11	Right Ramp Exit
48	5467-12693-19	Right Freeway
51	5647-12693-11	Left Ramp Enter
52	5647-12693-11	Left Ramp Exit
53	5647-12693-11	Center Ramp
54	SW-1A-120	Upper Rebound
55	5647-12693-19	Left Loop
56	A-18017-6	Standup 2
57	A-18019-6	Standup 3
58	A-18019-6	Standup 4
61	5647-12693-11	Side Ramp Enter
62	5647-12693-11	Side Ramp Exit
63	5467-12693-19	Left Rollover
64	5467-12693-19	Center Rollover
65	5467-12693-19	Right Rollover
66	5647-12133-11	Eject
67	A-17596	Elevator Index
68	Not Used	Not Used
71	A-16908 (LED)	Chase Car 1
	A-16909 (Transistor)	
72	A-16908 (LED)	Chase Car 2
	A-16909 (Transistor)	
73	A-16908 (LED)	Top Popper
	A-16909 (Transistor)	
74	A-16908 (LED)	Elevator Hold
	A-16909 (Transistor)	
75	Not Used	Not Used
76	A-16908 (LED)	Bottom Popper
	A-16909 (Transistor)	
77	A-18018-4	Eyeball Standup
78	A-18017-6	Standup 1

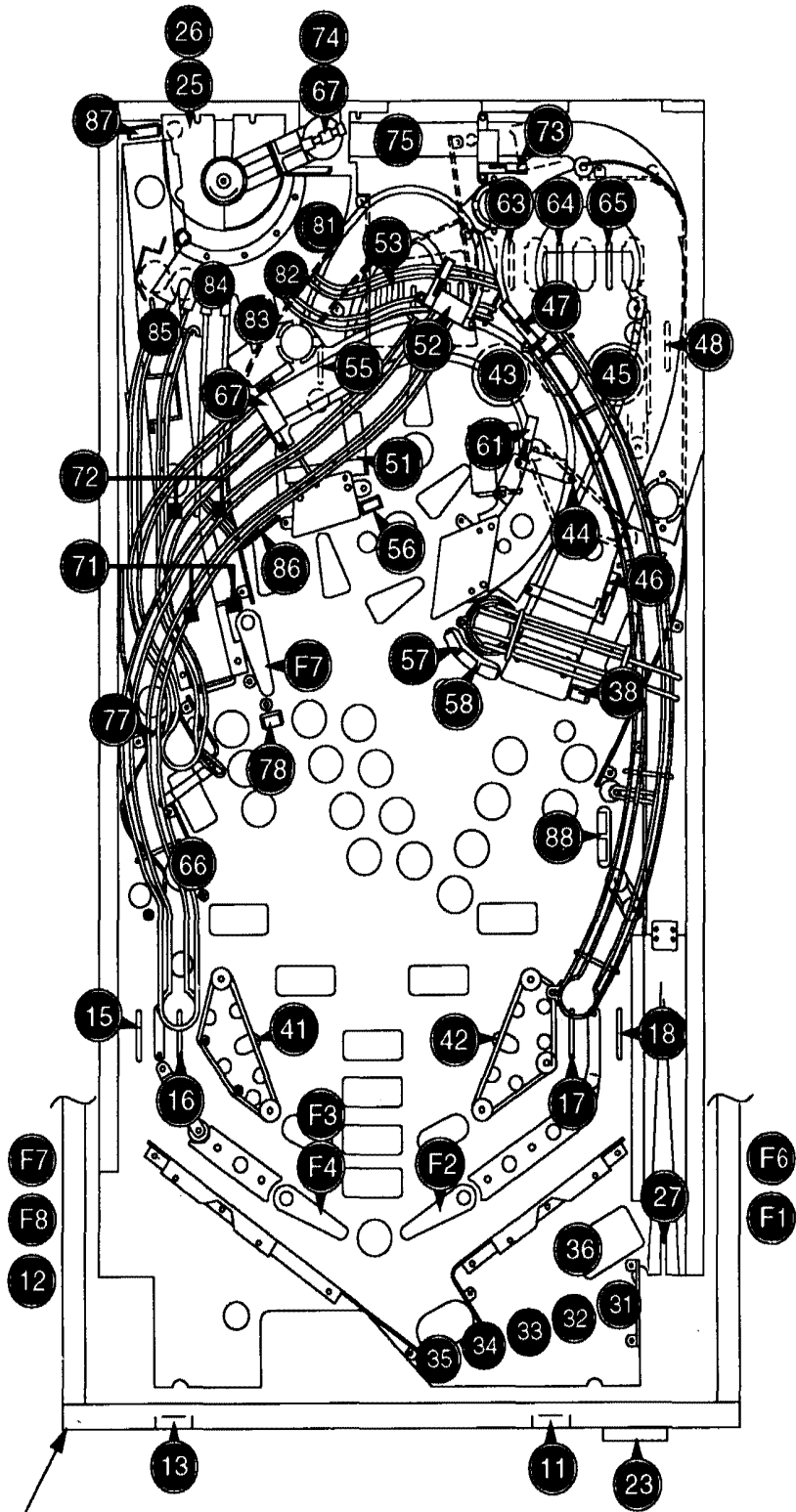

Cabinet shown for reference only.

Item	Switch No.	Where Used
81	5647-12073-17	Claw "Capture Simon"
82	5647-12693-21	Claw "Sup. Jets"
83	5647-12693-21	Claw "Prison Break"
84	5647-12693-21	Claw "Freeze"
85	5647-12693-21	Claw "ACMAG"
86	5647-12693-11	Upper Left Flipper Gate
87	A-18018-4	Car Chase Standup
88	SW-1A-120	Lower Rebound

* The Score slingshot switches have diodes across them.

SOLENOID/FLASHER TABLE

Sol. No.	Function	Solenoid Type	Voltage Connections			Drive Xster	Drive Connections			Drive Wire Color	Solenoid Part No. Flashlamp Type	
			Playfield	Backbox	Cabinet		Playfield	Backbox	Cabinet		Playfield	Backbox
01	Ball Release	High Power	J107-3			Q82	J130-1			Vio-Brn	AE-26-1500	
02	Bottom Popper	High Power	J107-3			Q80	J130-2			Vio-Red	AE-23-800	
03	Auto Plunger	High Power	J107-3			Q78	J130-4			Vio-Org	AE-23-800	
04	Top Popper	High Power	J107-3			Q76	J130-5			Vio-Yel	AE-28-1500	
05	Diverter Power	High Power	J107-3			Q64	J130-6			Vio-Grm	A-15943-1	
06	Not Used	High Power				Q66				Vio-Blu		
07	Knocker	High Power		J107-3		Q68		J130-8		Vio-Blk		AE-23-800
08	Not Used	High Power				Q70				Vio-Gry		
09	Left Slingshot	Low Power	J107-2			Q58	J127-1			Brn-Blk	AE-26-1200	
10	Right Slingshot	Low Power	J107-2			Q56	J127-3			Brn-Red	AE-26-1200	
11	Left Jet Bumper	Low Power	J107-2			Q54	J127-4			Brn-Org	AE-26-1200	
12	Top Slingshot	Low Power	J107-2			Q52	J127-5			Brn-Yel	AE-26-1200	
13	Right Jet Bumper	Low Power	J107-2			Q50	J127-6			Brn-Grm	AE-26-1200	
14	Eject	Low Power	J107-2			Q48	J127-7			Brn-Blu	AE-26-1200	
15	Diverter Hold	Low Power	J107-2			Q46	J127-8			Brn-Vio	A-15943-1	
16	Not Used	Low Power				Q44				Brn-Gry		
17	Claw Flasher	Low Power	J107-6	J106-5		Q42	J126-1	J125-1		Blk-Brn	#906 (1)	#906 (1)
18	Elevator Motor		J118-2			Q40	J126-2			Blk-Red	14-7993	
19	Claw Motor Left		J118-2			Q38	J126-3			Blk-Org	14-7992	
20	Claw Motor Right		J118-2			Q36	J126-4			Blk-Yel	14-7992	
21	Jets Flasher	Flasher	J107-6	J106-5		Q28	J126-5	J125-6		Blu-Grm	#89 (1)	#906 (1)
22	Side Ramp Flasher	Flasher	J107-6	J106-5		Q30	J126-6	J125-7		Bru-Blk	#89 (1)	#906 (1)
23	Left Ramp Up Flshr	Flasher	J107-6	J106-5		Q34	J126-7	J125-8		Blu-Vio	#906 (1)	#906 (1)
24	Left Ramp Lwr Flshr	Flasher	J107-6	J106-5		Q32	J126-8	J125-9		Blu-Gry	#89 (1)	#906 (1)
25	Car Chase Cntr Flshr	Gen. Purpose	J107-6	J106-5		Q26	J122-1	J124-1		Blu-Brn	#89 (1)	#906 (1)
26	Car Chase Lwr Flshr	Gen. Purpose	J107-6	J106-5		Q24	J122-2	J124-2		Blu-Red	#89 (1)	#906 (1)
27	Right Ramp Flasher	Gen. Purpose	J107-6	J106-5		Q22	J122-3	J124-3		Blu-Org	#89 (1)	#906 (1)
28	Eject Flasher	Gen. Purpose	J107-6	J106-5		Q20	J122-4	J124-5		Blu-Yel	#89 (1)	#906 (1)
29-36	See Flipper Circuits											
37*	Car Chase Up Flshr	Low Power	J107-6			Q16	J4-2			Bru-Wht	#89 (1)	
38*	Lower Rebound Flshr	Low Power	J107-6			Q15	J4-4			Blk-Wht	#89 (1)	
39*	Eyeball Flasher	Low Power	J107-6			Q14	J4-5			Org-Wht	#89 (1)	
40*	Center Ramp Flasher	Low Power	J107-6			Q13	J4-6			Yel-Wht	#89 (1)	
41*	Elevator 2 Flasher	Low Power	J107-6			Q9	J3-2			Grm-Wht	#906 (2)	
42*	Elevator 1 Flasher	Low Power	J107-6			Q10	J3-3			Blu-Wht	#906 (1)	
43*	Diverter Flasher	Low Power	J107-6			Q11	J3-4			Vio-Wht	#906 (1)	
44*	Rt. Ramp Up Flasher	Low Power	J107-6			Q12	J3-5			Gry-Wht	#906 (1)	

*Note: Controlled from the 8-Driver Board, not the Power Driver Board

General Illumination

01	Back Panel G.I.	G.I.	J121-1	J120-1		Q18	J121-7	J120-7		Wht-Brn	#44	#555
02	Upper Right G.I.	G.I.	J121-2	J120-2		Q10	J121-8	J120-8		Wht-Org	#44	#555
03	Upper Left G.I.	G.I.	J121-3	J120-3		Q14	J121-9	J120-9		Wht-Yel	#44	#555
04	Lower Right G.I.	G.I.	J121-5	J120-5		Q16	J121-10	J120-10		Wht-Gm	#44	#555
05	Lower Left G.I.	G.I.	J121-6	J120-6	J119-3	Q12	J121-11	J120-11	J119-1	Wht-Vio	#44	#555

Flipper Circuits		Solenoid Type	Voltage Connections		Drive Transistors		Drive Connections		Drive Wire Colors		Coil Part Number	Coil Colors
			Playfield	Backbox	Power	Hold	Playfield	Backbox	Power	Hold		
(29)		Lwr. Rt. Power	J907-1 (Red-Gm)		Q4		J902-13		Yel-Grm			
(30)	Lower Right Flipper	Lwr. Rt. Hold	J907-1 (Red-Gm)			Q11	J902-11		Org-Grm	FL-11629	Blue	
(31)		Lwr. Lt. Power	J907-4 (Red-Blu)		Q3		J902-9		Yel-Blu			
(32)	Lower Left Flipper	Lwr. Lt. Hold	J907-4 (Red-Blu)			Q9	J902-7		Org-Blu	FL-11629	Blue	
(33)	Claw Magnet	Up Rt. Power	J907-6 (Red-Vio)		Q2		J902-6		Yel-Vio	SZ-33-3000		
(34)	Not Used	Up Rt. Hold	J907-6 (Red-Vio)			Q7	J902-4		Org-Vio			
(35)		Up Lt. Power	J907-8 (Red-Gry)		Q1		J902-3		Yel-Gry			
(36)	Upper Left Flipper	Up Lt. Hold	J907-8 (Red-Gry)			Q5	J902-1		Org-Gry	FL-11630	Red	

J1XX-X = Power Driver Board, JX-X = 8-driver Board, J9XX-X = Fliptronic II Board

SOLENOID/FLASHER LOCATION

Item No.	Coil/Flasher No.	Assy No.	Description
01	AE-26-1500	A-16765	Ball Release
02	AE-23-800	A-17620	Bottom Popper
03	AE-23-800	A-14525	Auto Plunger
04	AE-28-1500	A-17215	Top Popper
05	A-15943-1	A-17241	Diverter Power
06			Not Used
07	AE-23-800	B-10686-1	Knocker
08			Not Used
09	AE-26-1200	A-17809	Left Slingshot
10	AE-26-1200	A-17809-1	Right Slingshot
11	AE-26-1200	A-9415-2	Left Jet Bumper
12	AE-26-1200	A-17809	Top Slingshot
13	AE-26-1200	A-9415-2	Right Jet Bumper
14	AE-26-1200	A-17809	Eject
15	A-15943-1	A-17241	Diverter Hold
16			Not Used
17	24-8802	C-13337	Claw Flasher #906
	24-8802	----	Insert Flasher #906
18	14-7993	A-17597	Elevator Motor
19	14-7992	A-16989	Claw Motor Left
20	14-7992	A-16989	Claw Motor Right
21	24-8704	A-17803	Jets Flasher #89
	24-8802	----	Insert Flasher #906
22	24-8704	A-17983	Side Ramp Flasher #89
	24-8802	----	Insert Flasher #906
23	24-8802	----	Left Ramp Upper Flshr #906
	24-8802	----	Insert Flasher #906
24	24-8704	A-17983	Left Ramp Lower Flasher #89
	24-8802	----	Insert Flasher #906
25	24-8704	A-17803	Car Chase Center Flshr #89
	24-8802	----	Insert Flasher #906
26	24-8704	A-17803	Car Chase Lower Flshr #89
	24-8802	----	Insert Flasher #906
27	24-8704	A-17983	Right Ramp Flasher #89
	24-8802	----	Insert Flasher #906
28	24-8704	A-17983	Eject Flasher #89
	24-8802	----	Insert Flasher #906
29 to 36 see Flipper Circuits			
37	24-8704	A-17803	Car Chase Upper Flshr #89
38	24-8704	A-17983	Lower Rebound Flasher #89
39	24-8704	A-17803	Eyeball Flasher #89
40	24-8704	A-17983	Center Ramp Flasher #89
41	24-8802	C-13337	Elevator 2 Flasher #906
42	24-8802	C-13337	Elevator 1 Flasher #906
43	24-8802	----	Diverter Flasher #906
44	24-8802	----	Right Ramp Up Flasher #906

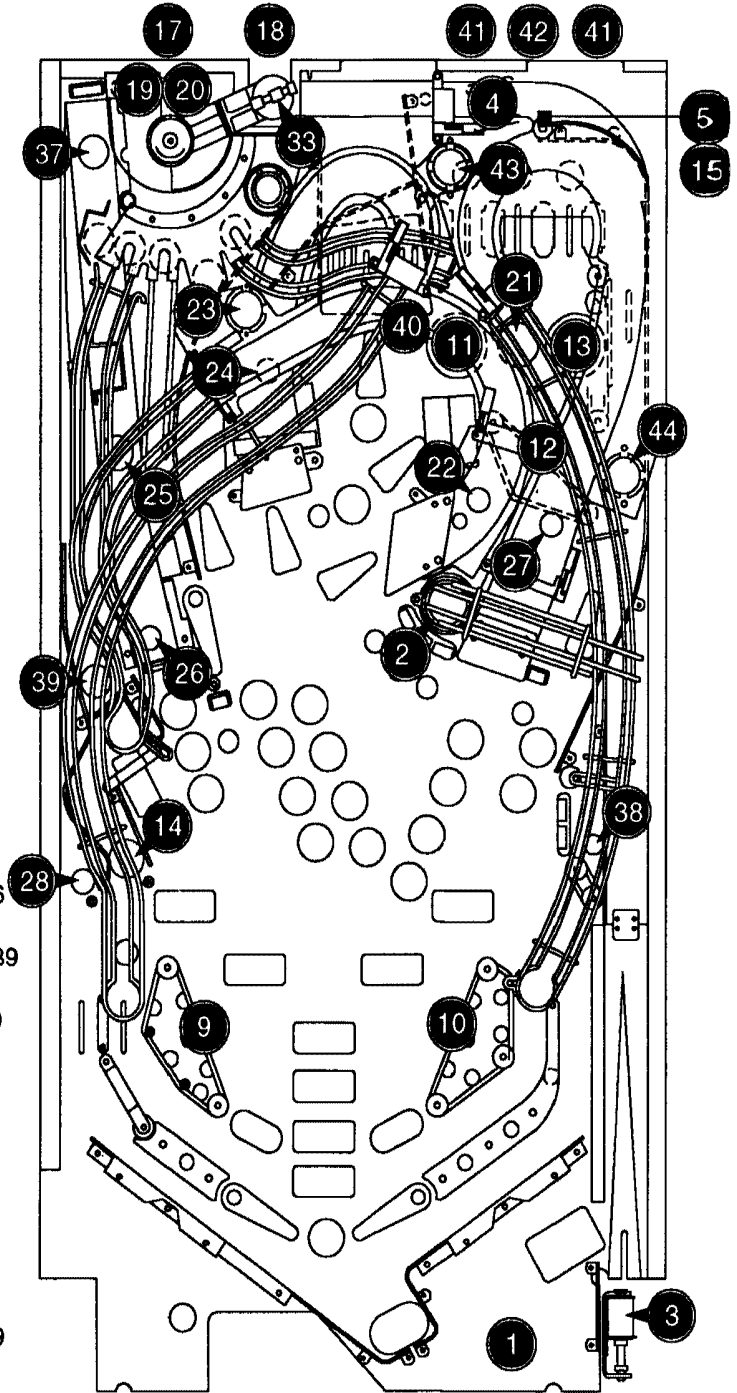

General Illumination

01	24-6549/24-8768	----	*Back Panel G.I.	29-30	FL-11629	A-15849-R-2	*Lower Right Flipper
02	24-6549/24-8768	----	*Upper Right G.I.	31-32	FL-11629	A-15849-L-2	*Lower Left Flipper
03	24-6549/24-8768	----	*Upper Left G.I.	33	SZ-33-3000		Claw Magnet
04	24-6549/24-8768	----	*Lower Right G.I.	34			Not Used
05	24-6549/24-8768	----	*Lower Left G.I.	35-36	FL-11630	A-14876-L	*Upper Left Flipper

* Not Shown

RAMP LOCATIONS

Item	Part Number	Description
1.	A-17784	Diverter Ramp Assembly
	A-18383	Super Jackpot Assembly
	5647-12693-36	Switch
	5647-12693-11	Switch
2.	A-17785	Ramp Assembly #2
	5647-12693-11	Switch
	A-18126	Wasteland PCB Assembly
3.	12-7171	Wire Cage
4.	A-18057	Cryo-Bracket Assembly
5.	A-17644	Opto Car Tunnel Assembly
6.	12-7182	Double Wire Ramp Cryoclaw
7.	12-7135	Wire Ramp #2
8.	12-7136	Wire Ramp #3
9.	12-7134	Wire Divertor-Ramp #1
10.	A-17786	Ramp Assembly #3
	5647-12693-11	Switch
11.	A-17291	Inclined Ramp Assembly
12.	A-17771	Feed Ramp Assembly
13.	A-17823	Ball Popper Trough Assembly
	01-12378	Trough Impact Plate
14.	12-7166	Single Wire Ramp, Cryo
15.	12-7181	Wire Drain - Cryoclaw

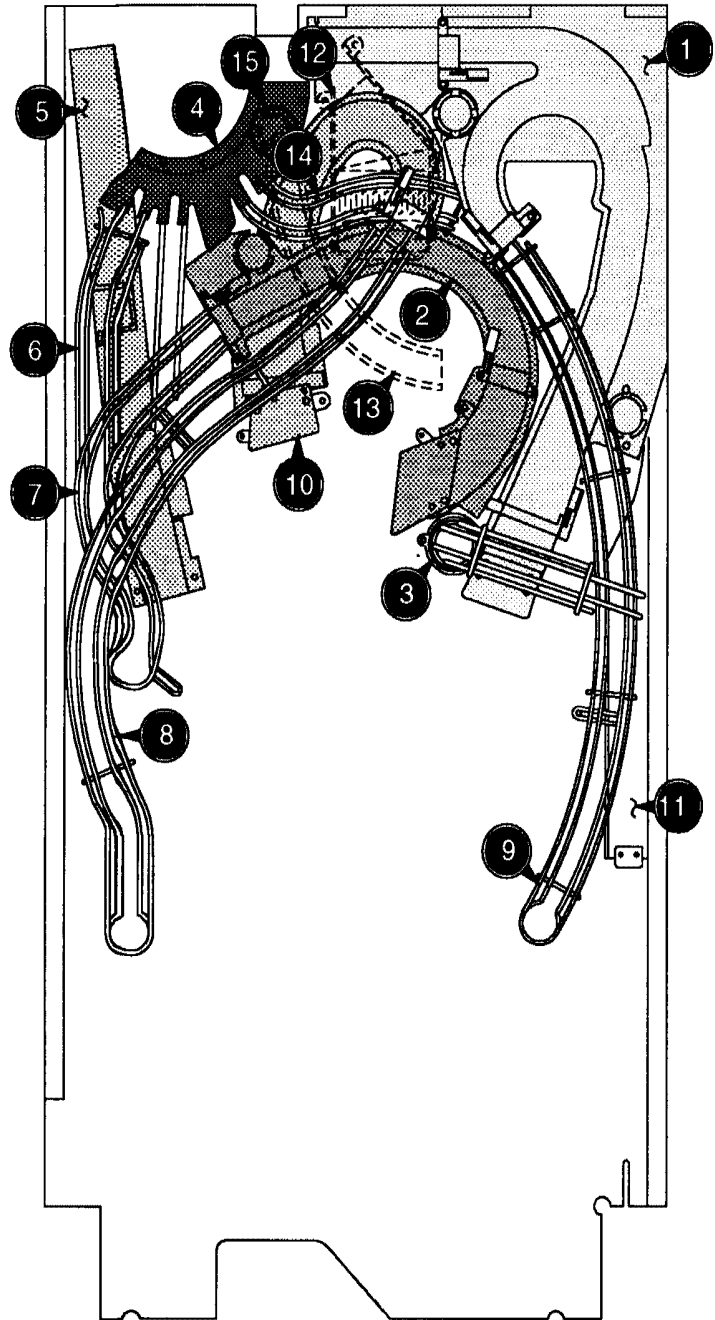

SECTION 3

Schematics, Wiring Diagrams, and Circuit Theory

CONNECTOR & COMPONENT IDENTIFICATION

Each plug or jack -except the Audio Board and Dot Matrix Display/Driver Board - receives a number that identifies the circuit board and position on that board that it connects to. J-designations refer to the male part of a connector. P-designations refer to the female part of a connector. For example, J101 designates jack 1 of board 1 (a Power Driver Board jack); P206 designates plug 6 of board 2 (a CPU Board plug). Identifying the specific pin number of a connector involves a hyphen, which separates the pin number from the plug or jack designation. For example, J101-3 refers to pin 3 of jack 1 on board 1.

Other game components may also have similar numbers to clarify their locations or related circuits. For example, F501 refers to a fuse located on the Audio Board.

Prefix numbers for the WPC circuit boards are listed below.

- 1- Power Driver Board
- 2- CPU Board
- 6- Dot Matrix Controller
- 9-Fliptronic II Controller Board

Audio Board and Dot Matrix Display/Driver Board do not have an identification number.

Schematics for standard WPC backbox boards are found in the WPC Schematics Manual. Playfield, cabinet and all other backbox board schematics are found in this section.

SWITCHES

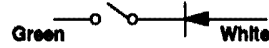

Dedicated Grounded Switches	Column	1 Green-Brown J207-1 U20-18	2 Green-Red J207-2 U20-17	3 Green-Orange J207-3 U20-16	4 Green-Yellow J207-4 U20-15	5 Green-Black J207-5 U20-14	6 Green-Blue J207-6 U20-13	7 Green-Violet J207-7 U20-12	8 Green-Gray J207-9 U20-11	Flipper Grounded Switches
	Row	11	21	31	41	51	61	71	81	
Orange-Brown J205-1 Left Coin Chute D1	White-Brown J209-1 U18-11	Ball Launch	Slam Tilt	Trough 1	Left Slingshot	Left Ramp Enter	Side Ramp Enter	Chase Car 1	Claw "Capture Simon"	Black-Green J906-1 Lower Right E.O.S. F1
Orange-Red J205-2 Center Coin Chute D2	White-Red J209-2 U18-9	Left Handle Button	Coin Door Closed	Trough 2	Right Slingshot	Left Ramp Exit	Side Ramp Exit	Chase Car 2	Claw "Sup. Jets"	Blue-Violet J905-1 Lower Right Opto F2
Orange-Black J205-3 Right Coin Chute D3	White-Orange J209-3 U18-5	Start Button	Buy-in Button	Trough 3	Left Jet Bumper	Center Ramp	Left Rollover	Top Popper	Claw "Prison Break"	Black-Blue J906-3 Lower Left E.O.S. F3
Orange-Yellow J205-4 4th Coin Chute D4	White-Yellow J209-4 U18-7	Plumb Bob Tilt	Always Closed	Trough 4	Top Slingshot	Upper Rebound	Center Rollover	Elevator Hold	Claw "Freeze"	Blue-Gray J905-2 Lower Left Opto F4
Orange-Green J205-6 Normal Function Service Credits D5	White-Green J209-5 U19-11	Left Outlane	Claw Position 1	Trough 5	Right Jet Bumper	Left Loop	Right Rollover	Not Used	Claw "ACMAG"	Black-Violet J906-4 Upper Right E.O.S.* F5
Orange-Blue J205-7 Normal Function Volume Down D6	White-Blue J209-7 U19-9	Left Inlane	Claw Position 2	Trough Jam	Right Ramp Enter	Standup 2	Eject	Bottom Popper	Upper Left Flipper Gate	Black-Yellow J905-3 Upper Right Opto* F6
Orange-Violet J205-8 Normal Function Volume Up D7	White-Violet J209-8 U19-5	Right Inlane	Shooter Lane	Not Used	Right Ramp Exit	Standup 3	Elevator Index	Eyeball Standup	Car Chase Standup	Black-Gray J906-5 Upper Left E.O.S. F7
Orange-Gray J205-9 Normal Function Begin Test D8	White-Gray J209-9 U19-7	Right Outlane	Not Used	Standup 5	Right Freeway	Standup 4	Not Used	Standup 1	Lower Rebound	Black-Blue J905-5 Upper Left Opto F8

Opto Switch * = Not Used

Switch Matrix Circuit

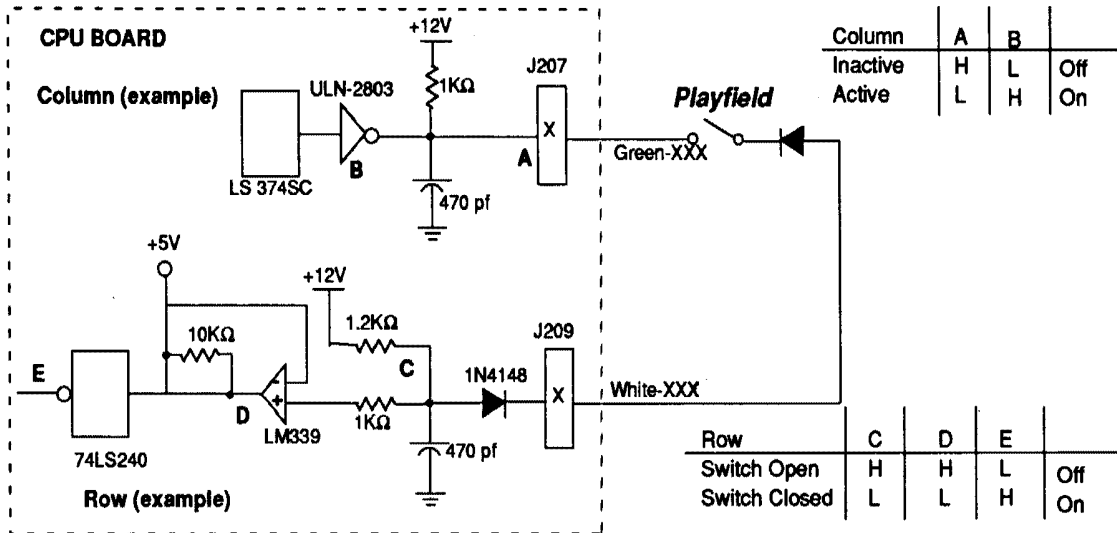

The microprocessor is constantly strobing the column side of the switch. When point "A" on the column circuit toggles low the column side is active.

When a switch closes the row side of the circuit activates. The "+" input to the LM339 drops below +5V therefore its output is low. Corresponding row and column switches must be low at the same time, for the switch to be considered closed by the microprocessor. When the switch opens, the "+" input to the LM339 is above +5V, its output is high and the row is inactive.

Dedicated Switches

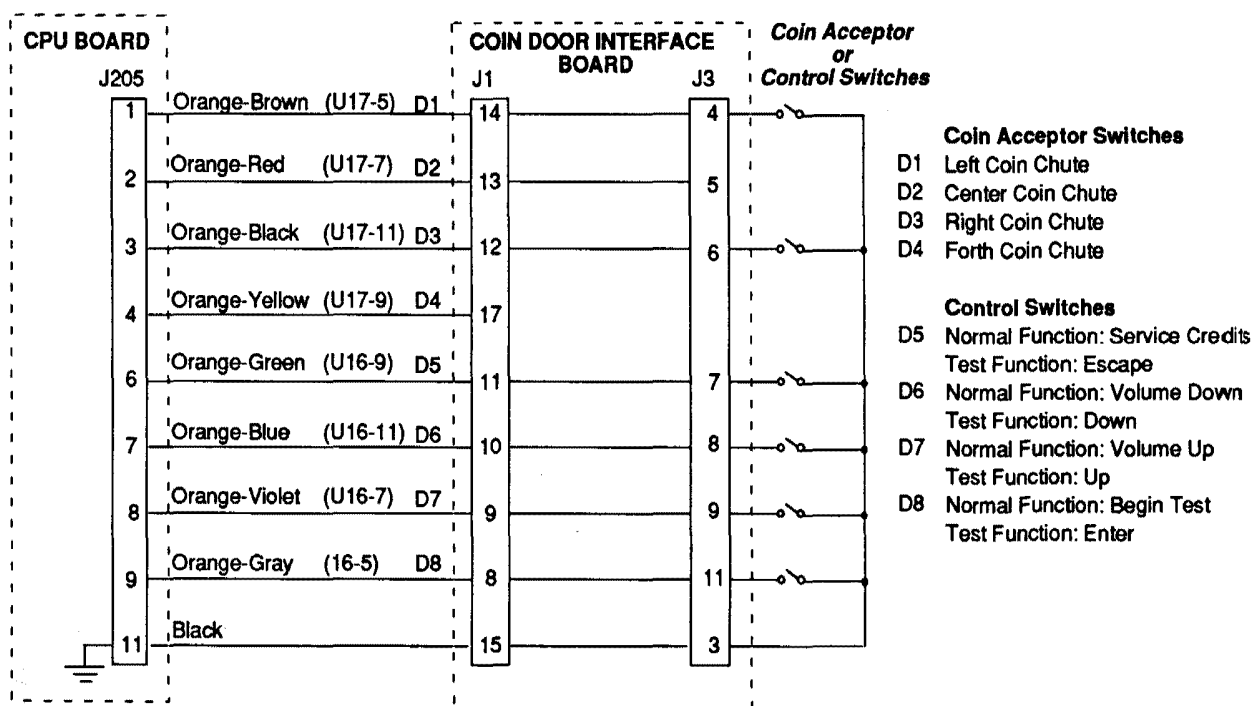

Dedicated Switch Circuit

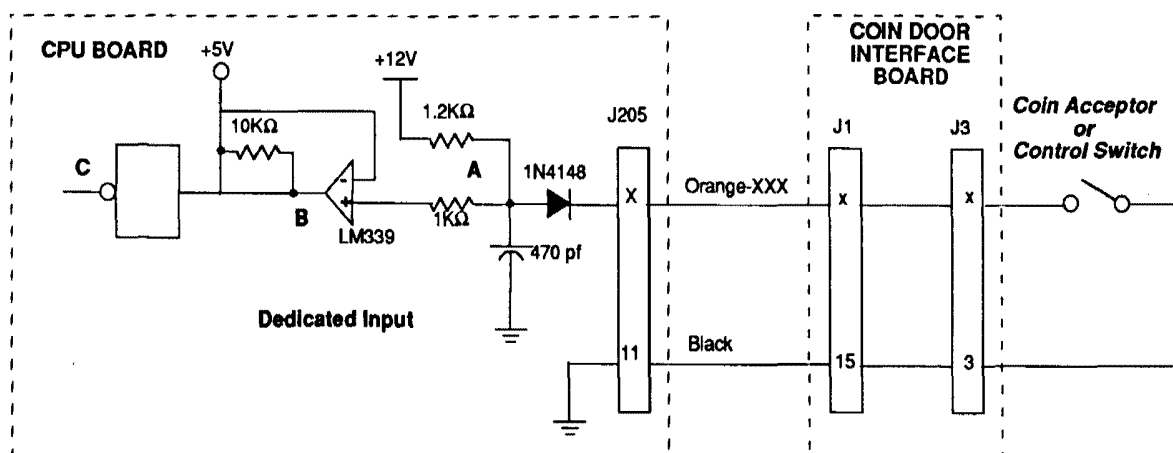

Switch	A	B	C	
Open	H	H	L	Off
Closed	L	L	H	On

The dedicated switches operate similar to switches in the matrix except that instead of a column circuit there is a direct tie to ground. Therefore, the column side is constantly active (low).

When a switch closes the row side (dedicated input) of the circuit activates. The "+" input to the LM339 drops below +5V therefore its output is low. Since the row circuit (dedicated input) is tied directly to ground through the switch, the switch is considered closed by the microprocessor. When the switch opens, the "+" input to the LM339 is above +5V, its output is high and the row is inactive.

LAMPS

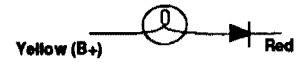

Column \ Row	1 Yellow-Brown J137-1 Q98	2 Yellow-Red J137-2 Q97	3 Yellow-Orange J137-3 Q96	4 Yellow-Black J137-4 Q95	5 Yellow-Green J137-5 Q94	6 Yellow-Blue J137-6 Q93	7 Yellow-Violet J137-7 Q92	8 Yellow-Gray J137-9 Q91
1 Red-Brown J134-1 Q90	Ball Save 11	Right Ramp Jackpot 21	Right Loop Jackpot 31	Right Ramp Explode 41	Underground Arrow 51	Claw "Capture Simon" 61	"Super Jackpot" 71	Center Ramp Middle 81
2 Red-Black J134-2 Q89	Fortress Multiball 12	Right Loop Explode 22	Standup 5 32	Right Ramp Car Chase 42	Underground Jackpot 52	Claw "Sup. Jets" 62	"Computer" 72	Center Ramp Outer 82
3 Red-Orange J134-4 Q88	Museum Multiball 13	Light Quick Freeze 23	Right Ramp Arrow 33	Quick Freeze 43	Standup 2 53	Claw "Prison Break" 63	"Demo Time" 73	Center Ramp Inner 83
4 Red-Yellow J134-5 Q87	Cryoprisn Multiball 14	Freeze 4 24	Left Ramp Jackpot 34	Left Ramp Car Chase 44	Left Ramp Arrow 54	Claw "Freeze" 64	Not Used 74	Center Ramp Arrow 84
5 Red-Green J134-6 Q86	Wasteland Multiball 15	Claw Ready 25	Left Loop Jackpot 35	Extra Ball 45	Side Ramp Jackpot 55	Claw "ACMAG" 65	Not Used 75	Right Loop Arrow 85
6 Red-Blue J134-7 Q85	Shoot Again 16	Freeze 3 26	Car Crash Top 36	Start Multiball 46	Side Ramp Arrow 56	Middle Rollover 66	Standup 4 76	Buy-In Button 86
7 Red-Violet J134-8 Q84	Access Claw 17	Freeze 2 27	Standup 1 37	Car Crash Bottom 47	Left Loop Arrow 57	Top Rollover 67	Standup 3 77	Ball Launch 87
8 Red-Gray J134-9 Q83	Left Ramp Explode 18	Freeze 1 28	Car Crash Center 38	Left Loop Explode 48	Center Ramp Jackpot 58	Lower Rollover 68	Retina Scan 78	Start Button 88

Lamp Matrix Circuit

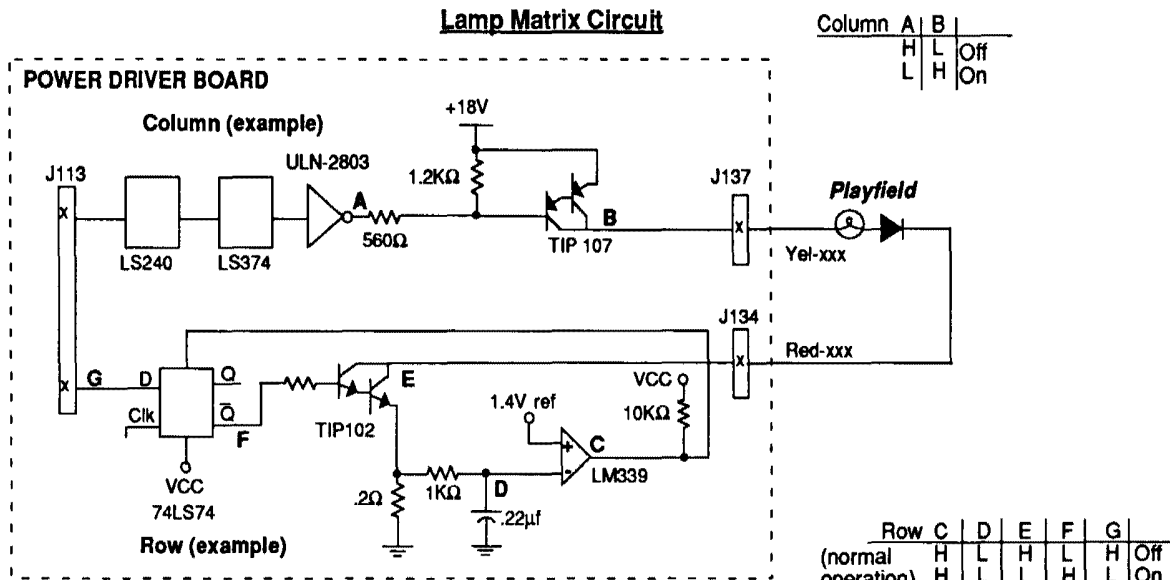

The processor sends a signal to the column circuit causing the output of the UNL-2803 to toggle. When point "A" drops low, the TIP107 transistor conducts and point "B" changes to a high state. At the same time the processor drives the input of the 74LS74 low, causing a high at output "F". A high state at the base of TIP102 causes the transistor to conduct bringing the row circuit to ground and turning the lamp On.

The processor changes the input of the 74LS74 to a high state to turn the lamp Off.

In overcurrent conditions the lamp is shut Off through the comparator. If the voltage at the negative input of the LM339 rises above 1.4V the output changes to a low, which is fed back to the 74LS74 and shuts the row circuit Off.

SOLENOID / FLASHER TABLE

Sol. No.	Function	Solenoid Type	Voltage Connections			Driver	Drive Connections			Drive Wire Color	Solenoid Part Number Flashlamp Type	
			Playfield	Backbox	Cabinet		Playfield	Backbox	Cabinet		Playfield	Backbox
01	Ball Release	High Power	J107-3			Q82	J130-1			Vio-Brn	AE-26-1500	
02	Bottom Popper	High Power	J107-3			Q80	J130-2			Vio-Red	AE-23-800	
03	Auto Plunger	High Power	J107-3			Q78	J130-4			Vio-Org	AE-23-800	
04	Top Popper	High Power	J107-3			Q76	J130-5			Vio-Yel	AE-28-1500	
05	Diverter Power	High Power	J107-3			Q64	J130-6			Vio-Grn	A-15943-1	
06	Not Used	High Power				Q66				Vio-Blu		
07	Knocker	High Power		J107-3		Q68		J130-8		Vio-Blk		AE-23-800
08	Not Used	High Power				Q70				Vio-Gry		
09	Left Slingshot	Low Power	J107-2			Q58	J127-1			Brn-Blk	AE-26-1200	
10	Right Slingshot	Low Power	J107-2			Q56	J127-3			Brn-Red	AE-26-1200	
11	Left Jet Bumper	Low Power	J107-2			Q54	J127-4			Brn-Org	AE-26-1200	
12	Top Slingshot	Low Power	J107-2			Q52	J127-5			Brn-Yel	AE-26-1200	
13	Right Jet Bumper	Low Power	J107-2			Q50	J127-6			Brn-Grn	AE-26-1200	
14	Eject	Low Power	J107-2			Q48	J127-7			Brn-Blu	AE-26-1200	
15	Diverter Hold	Low Power	J107-2			Q46	J127-8			Brn-Vio	A-15943-1	
16	Not Used	Low Power				Q44				Brn-Gry		
17	Claw Flasher	Low Power	J107-6	J106-5		Q42	J126-1	J125-1		Blk-Brn	#906 (1)	#906 (1)
18	Elevator Motor		J118-2			Q40	J126-2			Blk-Red	14-7993	
19	Claw Motor Left		J118-2			Q38	J126-3			Blk-Org	14-7992	
20	Claw Motor Right		J118-2			Q36	J126-4			Blk-Yel	14-7992	
21	Jets Flasher	Flasher	J107-6	J106-5		Q28	J126-5	J125-6		Blu-Grn	#89 (1)	#906 (1)
22	Side Ramp Flasher	Flasher	J107-6	J106-5		Q30	J126-6	J125-7		Blu-Blk	#89 (1)	#906 (1)
23	Left Ramp Up Flshr	Flasher	J107-6	J106-5		Q34	J126-7	J125-8		Blu-Vio	#906 (1)	#906 (1)
24	Left Ramp Lwr Flshr	Flasher	J107-6	J106-5		Q32	J126-8	J125-9		Blu-Gry	#89 (1)	#906 (1)
25	Car Chase Cntr Flshr	Gen. Purpose	J107-6	J106-5		Q26	J122-1	J124-1		Blu-Brn	#89 (1)	#906 (1)
26	Car Chase Lwr Flshr	Gen. Purpose	J107-6	J106-5		Q24	J122-2	J124-2		Blu-Red	#89 (1)	#906 (1)
27	Right Ramp Flasher	Gen. Purpose	J107-6	J106-5		Q22	J122-3	J124-3		Blu-Org	#89 (1)	#906 (1)
28	Eject Flasher	Gen. Purpose	J107-6	J106-5		Q20	J122-4	J124-5		Blu-Yel	#89 (1)	#906 (1)
29-36	<i>See Flipper Circuits</i>											
37*	Car Chase Up Flshr	Low Power	J107-6			Q16	J4-2			Brn-Wht	#89 (1)	
38*	Lower Rebound Flshr	Low Power	J107-6			Q15	J4-4			Blk-Wht	#89 (1)	
39*	Eyeball Flasher	Low Power	J107-6			Q14	J4-5			Org-Wht	#89 (1)	
40*	Center Ramp Flasher	Low Power	J107-6			Q13	J4-6			Yel-Wht	#89 (1)	
41*	Elevator 2 Flasher	Low Power	J107-6			Q9	J3-2			Gm-Wht	#906 (2)	
42*	Elevator 1 Flasher	Low Power	J107-6			Q10	J3-3			Blu-Wht	#906 (1)	
43*	Diverter Flasher	Low Power	J107-6			Q11	J3-4			Vio-Wht	#906 (1)	
44*	Rt. Ramp Up Flasher	Low Power	J107-6			Q12	J3-5			Gry-Wht	#906 (1)	

*Note: Controlled from the 8-Driver Board, not the Power Driver Board

General Illumination

01	Back Panel G.I.	G.I.	J121-1	J120-1		Q18	J121-7	J120-7		Wht-Brn	#44	#555
02	Upper Right G.I.	G.I.	J121-2	J120-2		Q10	J121-8	J120-8		Wht-Org	#44	#555
03	Upper Left G.I.	G.I.	J121-3	J120-3		Q14	J121-9	J120-9		Wht-Yel	#44	#555
04	Lower Right G.I.	G.I.	J121-5	J120-5		Q16	J121-10	J120-10		Wht-Gm	#44	#555
05	Lower Left G.I.	G.I.	J121-6	J120-6	J119-3	Q12	J121-11	J120-11	J119-1	Wht-Vio	#44	#555

	Flipper Circuits		Voltage Connections		Drive Transistors		Drive Connections		Drive Wire Colors		Coil Part Number	Coil Colors
			Playfield	Power	Power	Hold	Playfield	Power	Hold			
(29)	Lower Right Flipper	Lwr. Rt. Power	J907-1 (Red-Grn)	Q4		J902-13	Yel-Grn			FL-11629	Blue	
(30)		Lwr. Rt. Hold	J907-1 (Red-Grn)		Q11	J902-11	Org-Grn					
(31)	Lower Left Flipper	Lwr. Lt. Power	J907-4 (Red-Blu)	Q3		J902-9	Yel-Blu			FL-11629	Blue	
(32)		Lwr. Lt. Hold	J907-4 (Red-Blu)		Q9	J902-7	Org-Blu					
(33)	Claw Magnet	Up Rt. Power	J907-6 (Red-Vio)	Q2		J902-6	Yel-Vio			SZ-33-3000		
(34)	Not Used	Up Rt. Hold	J907-6 (Red-Vio)		Q7	J902-4	Org-Vio					
(35)	Upper Left Flipper	Up Lt. Power	J907-8 (Red-Gry)	Q1		J902-3	Yel-Gry			FL-11630	Red	
(36)		Up Lt. Hold	J907-8 (Red-Gry)		Q5	J902-1	Org-Gry					

J1XX-X = Power Driver Board, JX-X = 8-driver Board, J9XX-X = Fliptronic II Board

Solenoid Wiring

Power Driver PCB

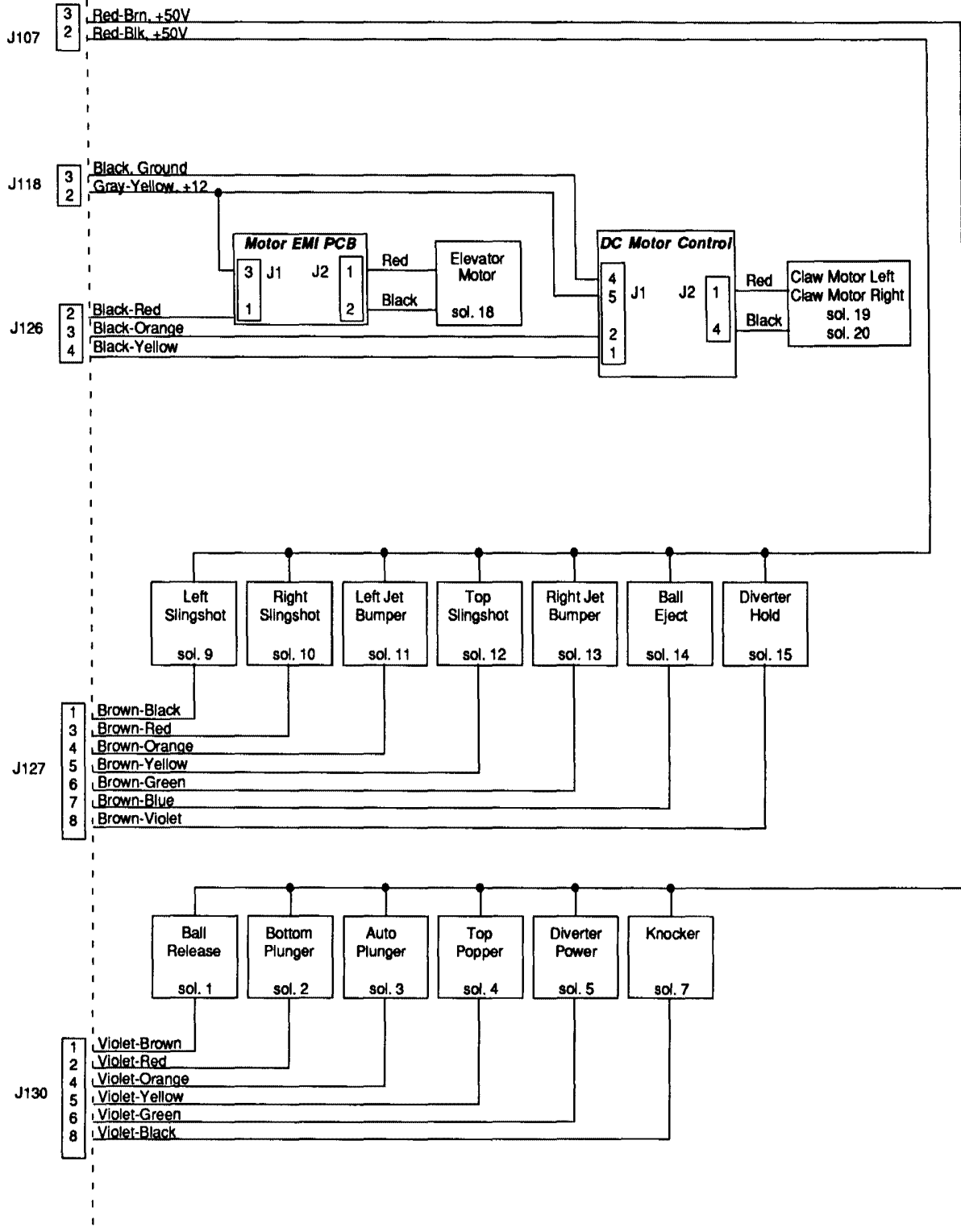

Flashlamp Wiring

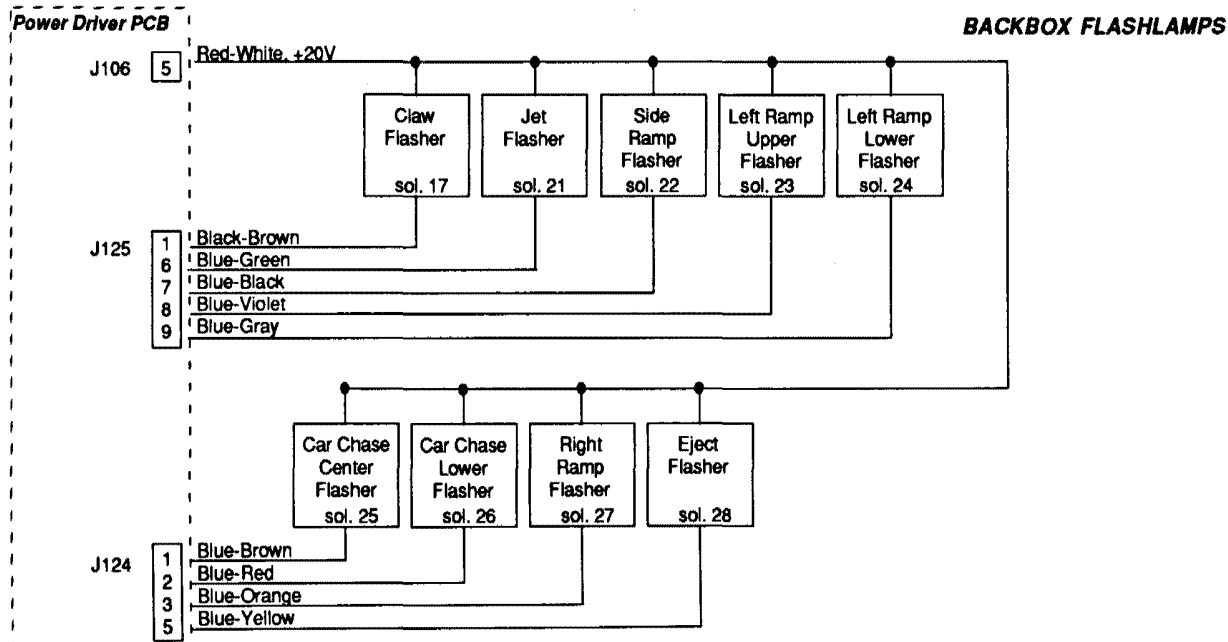
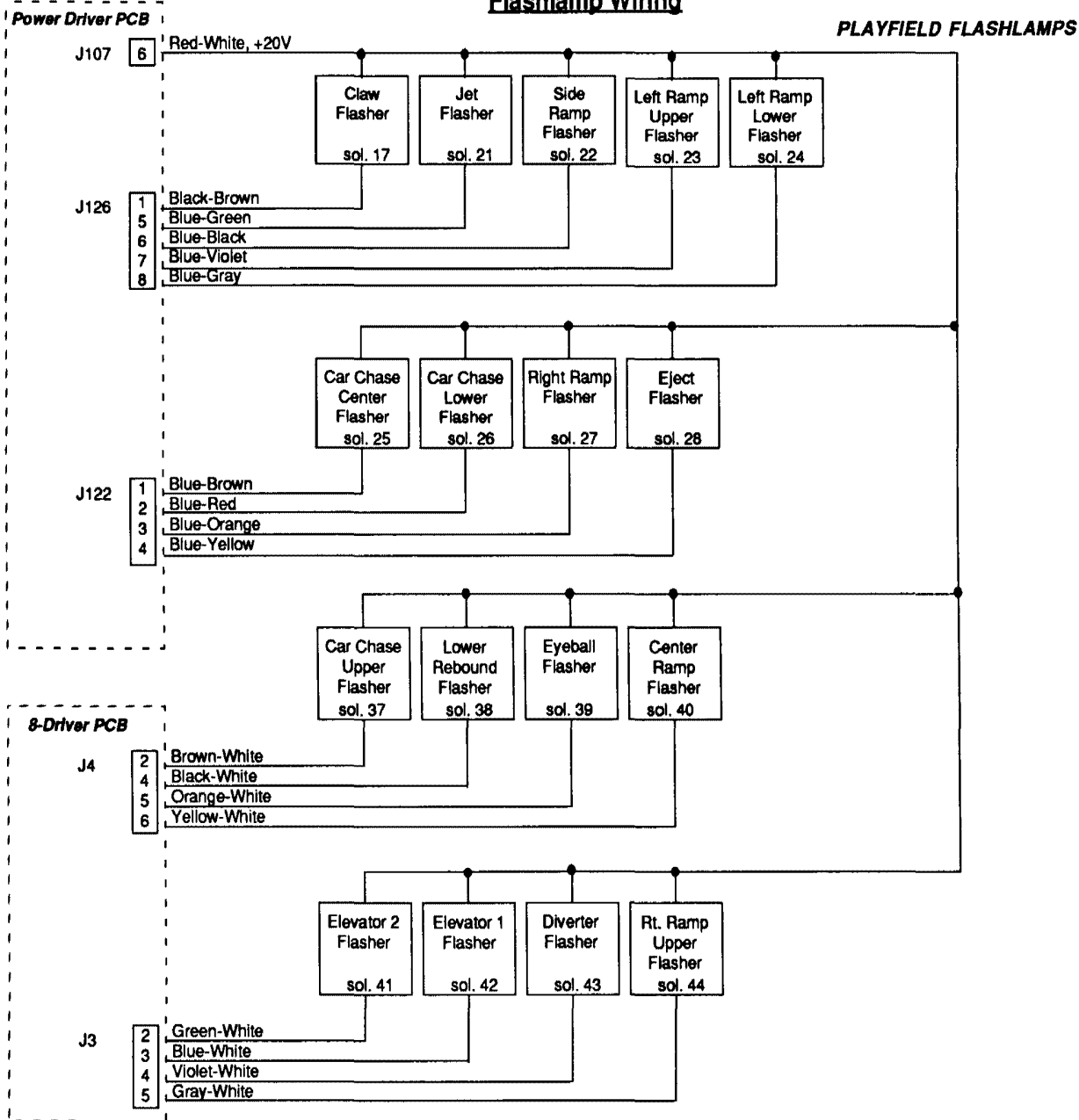

High Power Solenoid Circuit

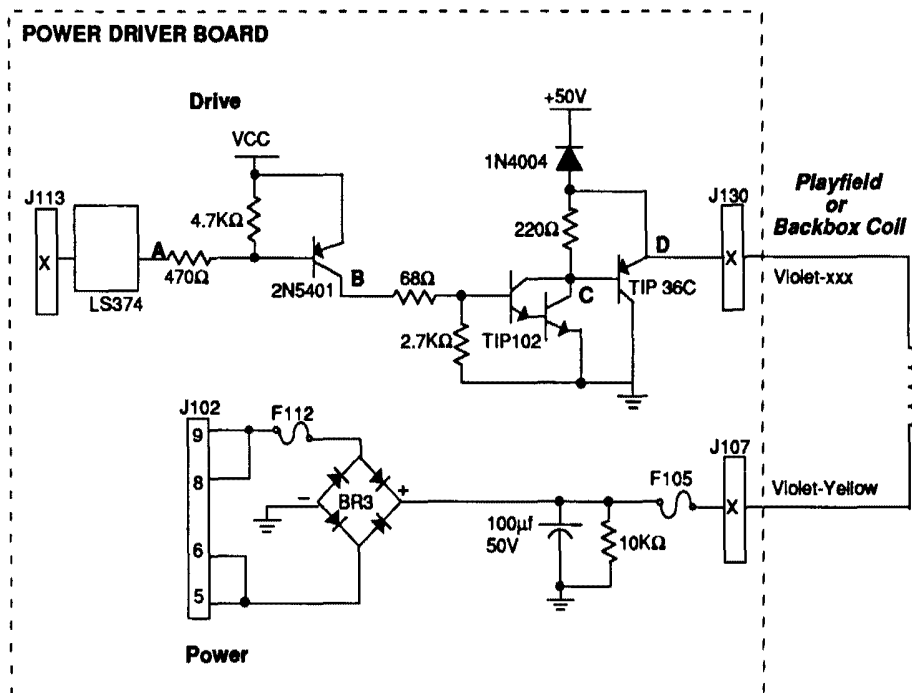

The microprocessor toggles the output of the 74LS374. When point "A" drops low, point "B" the collector of the 2N5401 transistor is high. A high at point "B" causes point "C" the collector of the TIP102 transistor, and point "D" the emitter of the TIP36 transistor to drop low. When point "D" is low the coil is grounded through the transistor and the coil turns On. The coil shuts Off when point "A" toggles high.

Low Power Solenoid Circuit

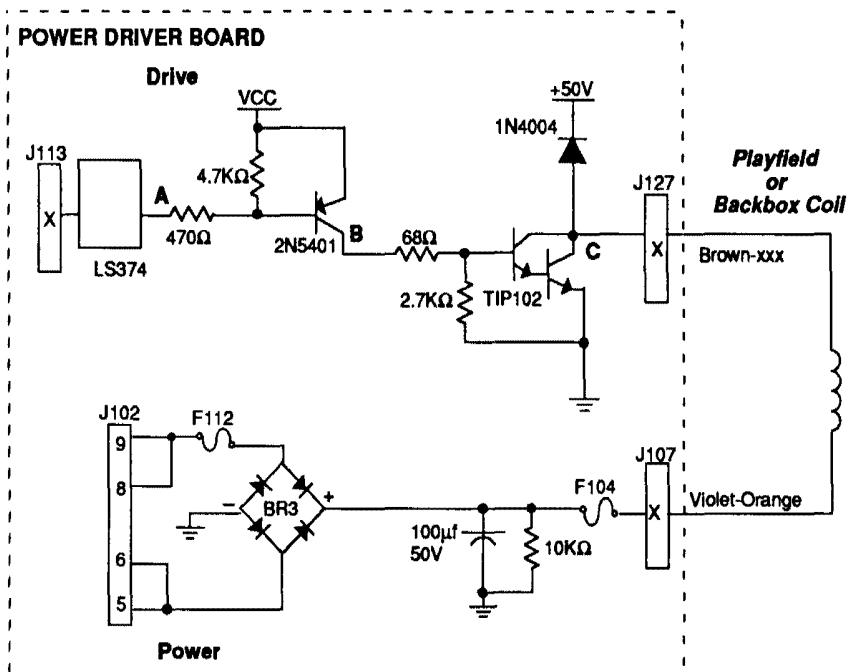

The microprocessor toggles the output of the 74LS374. When point "A" is low, point "B" the collector of the 2N5401 transistor is driven high. A high at point "B" turns On the TIP102 transistor and causes point "C" to drop low. When point "C" is low the coil is grounded through the transistor and the coil turns On. The coil shuts Off when point "A" toggles high.

Flashlamp Circuit

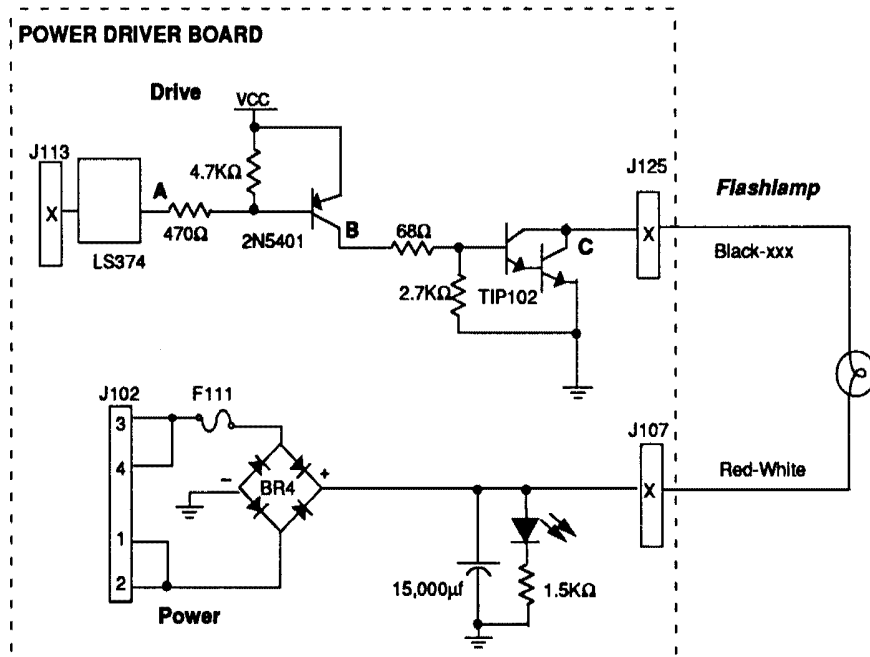

The microprocessor toggles the output of the 74LS374. When point "A" is low, point "B" the collector of the 2N5401 transistor is high. Once point "B" is high, point "C" the collector of the TIP102 transistor is low. When Point "C" is low the flashlamp is grounded through the transistor and the flashlamp turns On. When point "A" toggles high the circuit shuts Off.

Special (General Purpose) Solenoid Circuit

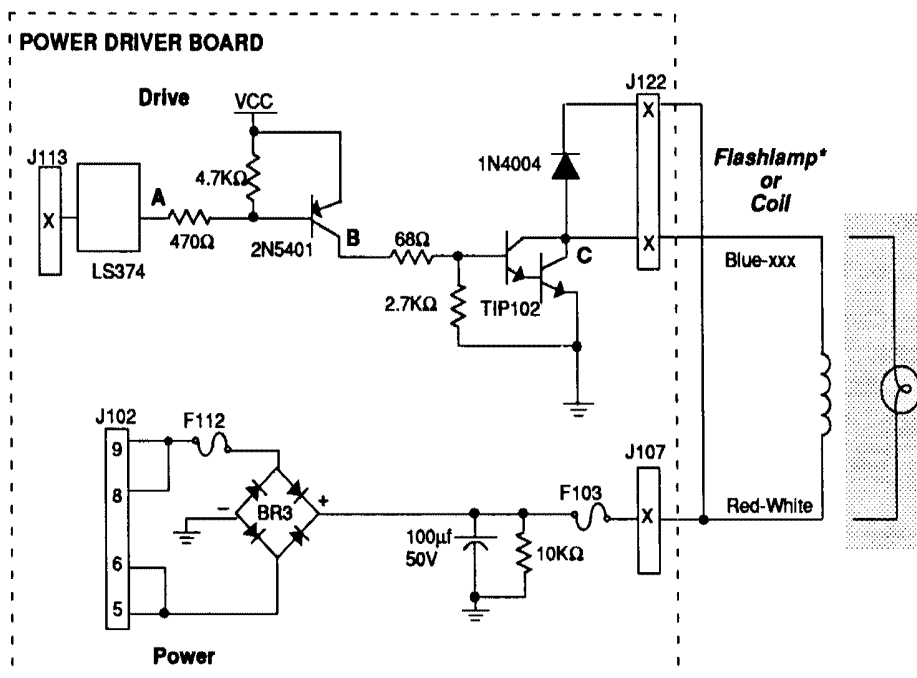

The microprocessor toggles the output of the 74LS374. When point "A" drops low, point "B" is high. A high at point "B" causes a low at point "C". When point "C" is low the coil/flashlamp is grounded through the transistor and the coil/flashlamp turns On. When point "A" toggles high the coil/flashlamp turns Off.

* Tieback Diode is not used for flashlamp circuit.

General Illumination Circuit

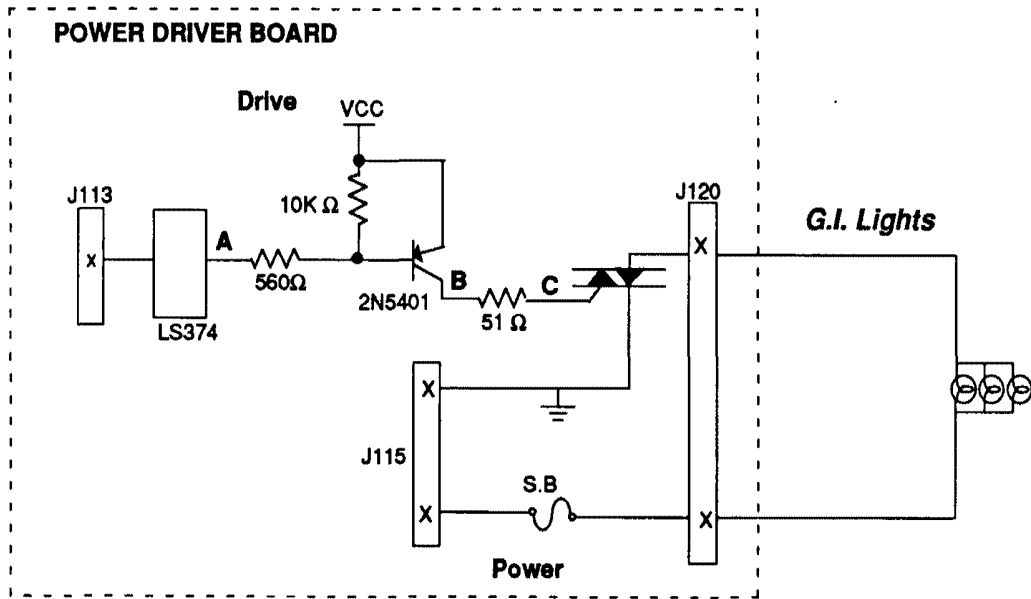

Block Diagram of General Illumination Circuit

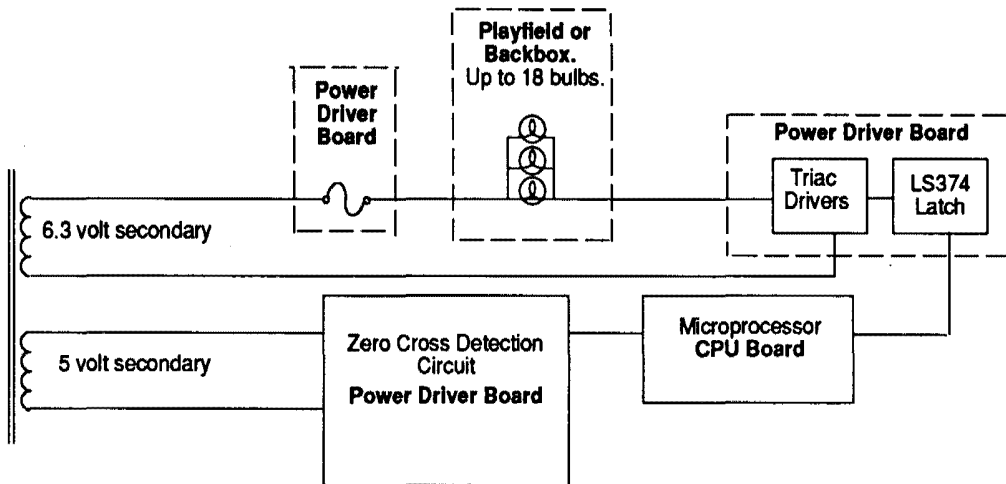

When point "A" toggles low, then points "B" and "C" are high. This turns On the triac and the desired General Illumination string lights.

Flipper Circuit Diagram

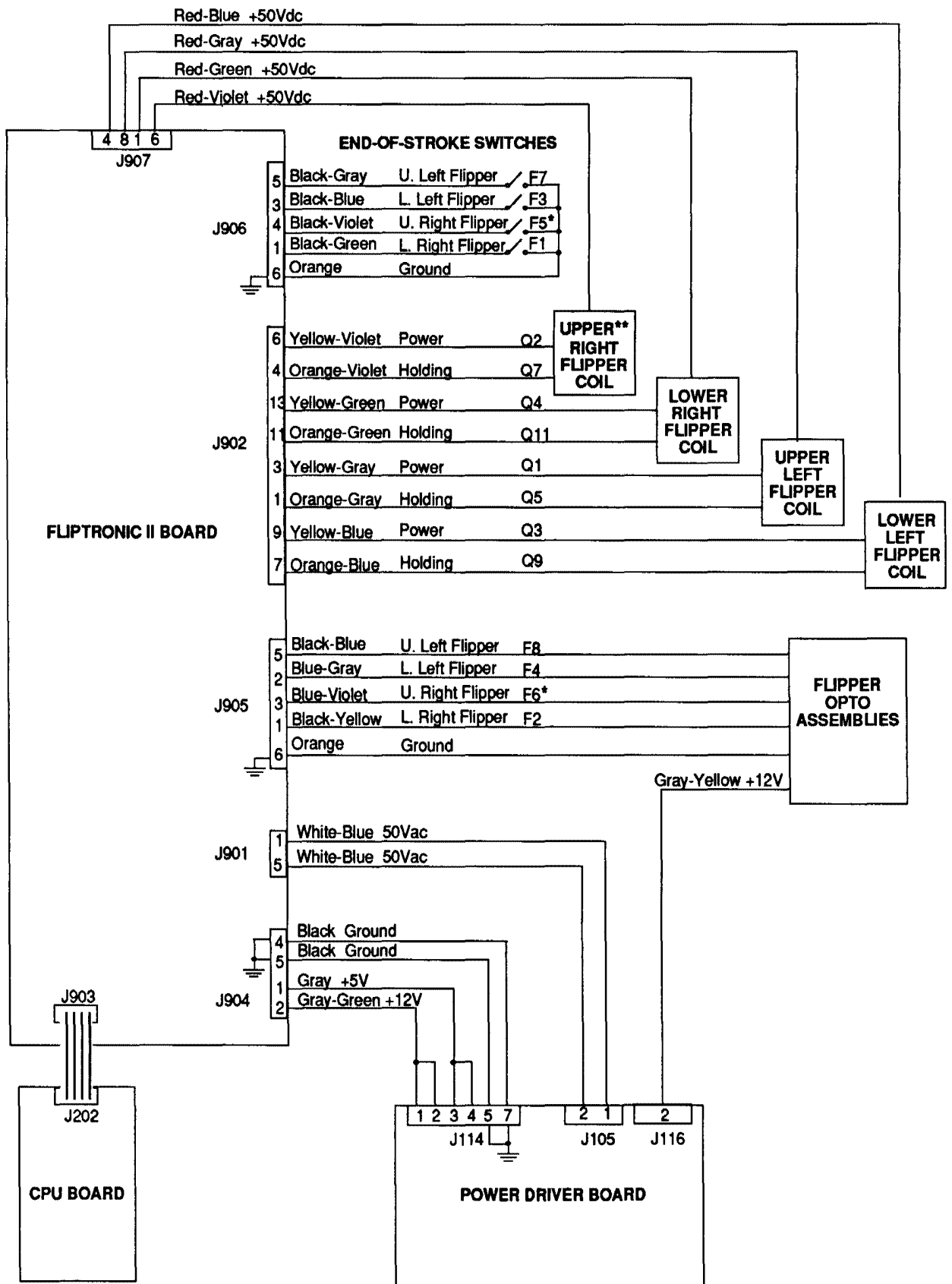

*Not used on this game.

** Upper right flipper power drive is used as the Claw magnet drive.
Upper right flipper holding drive is not used.

Flipper Coil Circuits

Left Flipper Circuit

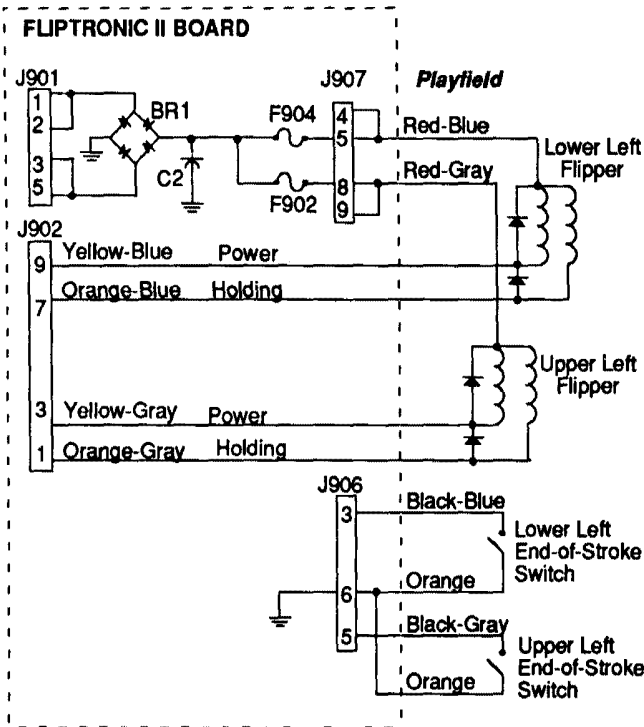

Right Flipper Circuit

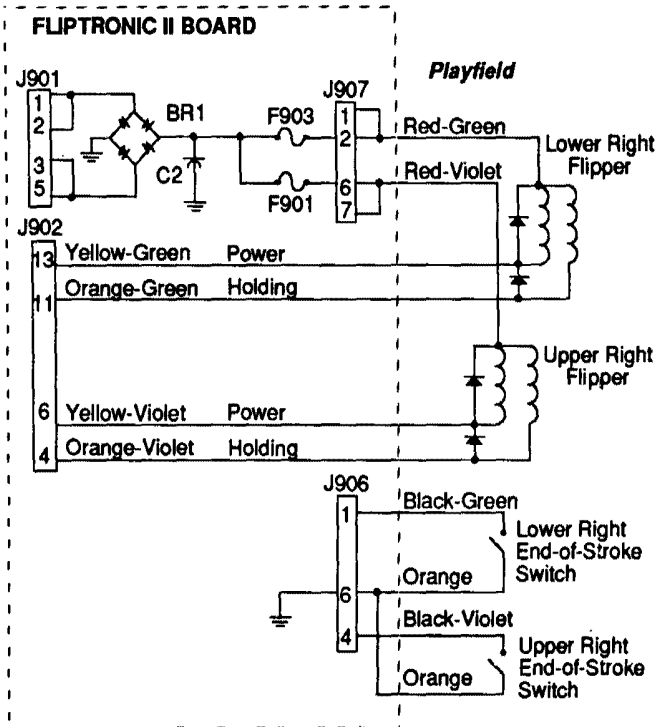

Flipper End-of-Stroke Switches

- F1 Lower Right Flipper
- F5 Upper Right Flipper
- F3 Lower Left Flipper
- F7 Upper Left Flipper

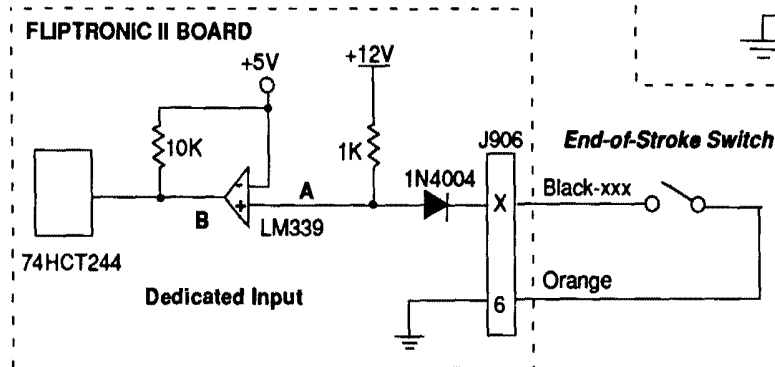
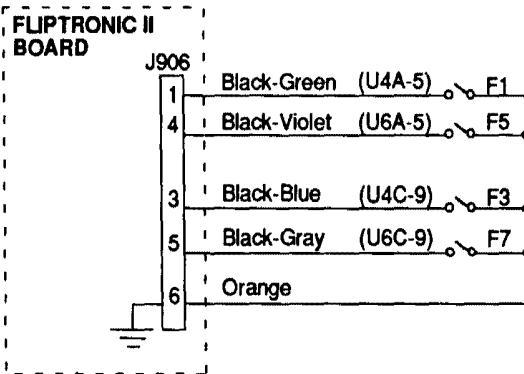

Switch	A	B	
Open	H	H	Off
Closed	L	L	On

The flipper switch circuits operate similar to the dedicated switch circuit. The circuits are active low and tied to ground through the switch.

When a switch closes the row side (dedicated input) of the circuit activates. The "+" input to the LM339 drops below +5V therefore its output is low. Since the row (dedicated input) circuit is tied directly to ground through the switch, the switch is considered closed by the microprocessor. When the switch opens, the "+" input to the LM339 is above +5V, its output is high and the row (dedicated input) is inactive.

Flipper Cabinet Switch Circuit Diagram

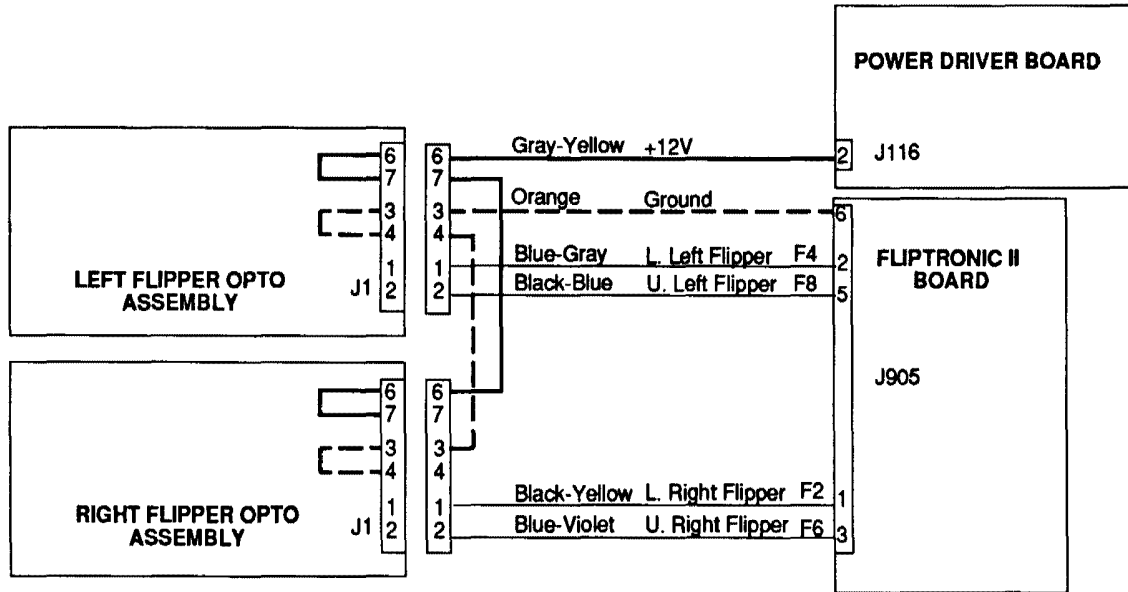

Flipper Cabinet Switches

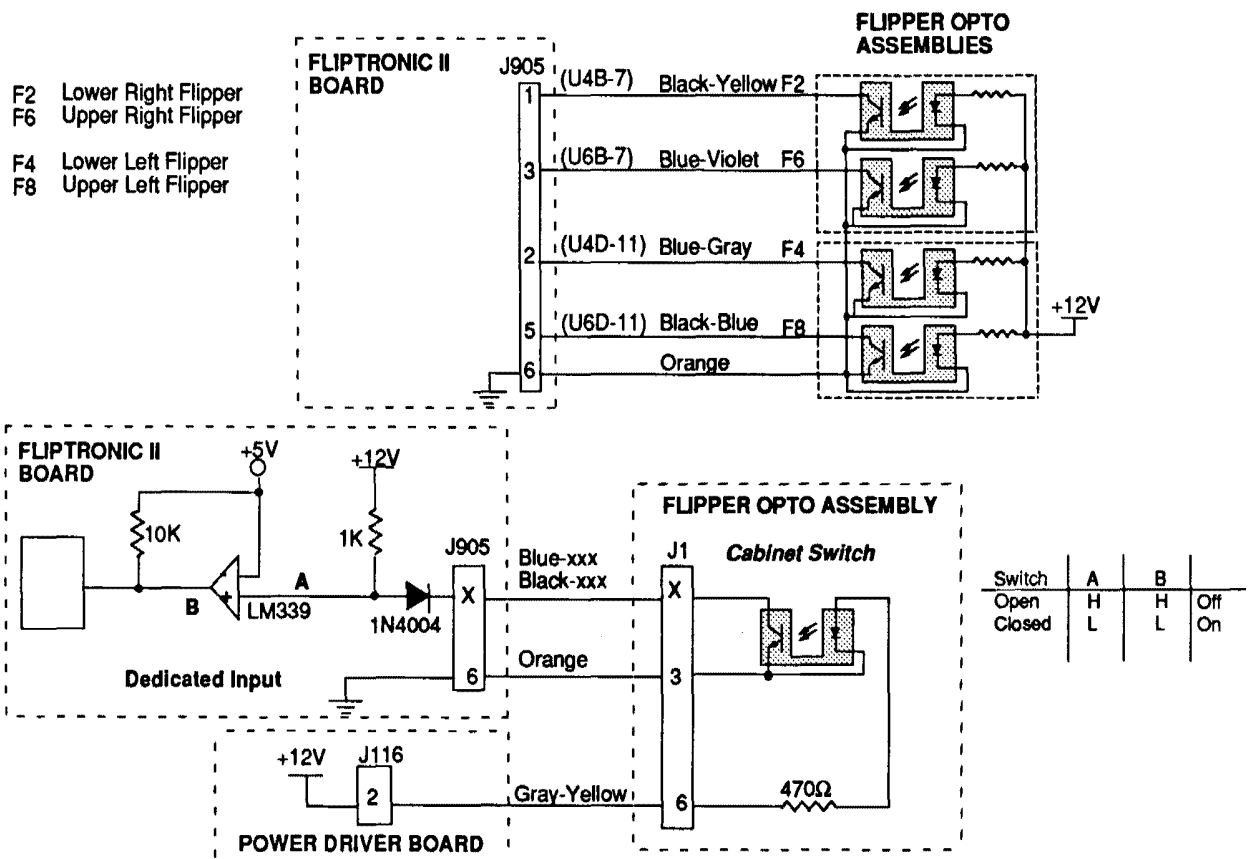

The flipper switch circuits operate similar to the dedicated switch circuit. The circuits are active low and tied to ground through the switch.

When a switch closes the row side (dedicated input) of the circuit activates. The "+" input to the LM339 drops below +5V therefore its output is low. Since the row (dedicated input) circuit is tied directly to ground through the switch, the switch is considered closed by the microprocessor. When the switch opens, the "+" input to the LM339 is above +5V, its output is high and the row (dedicated input) is inactive.

A-17316 Flipper Opto PCB Assembly

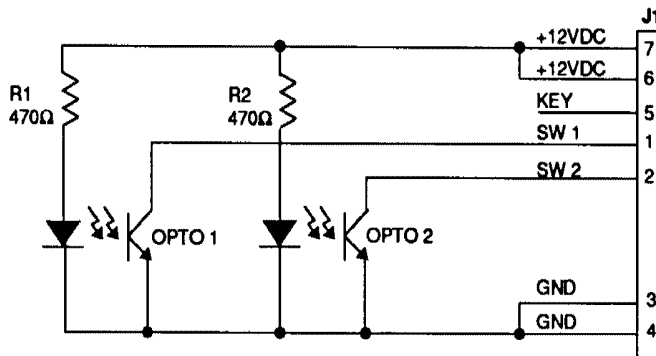
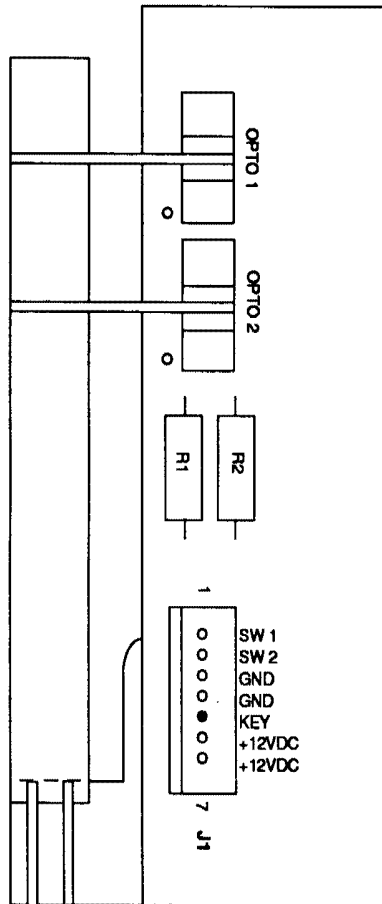

Left Side Flipper Cabinet Opto Switch Board

- J1-1 Blue-Gray from Fliptronic II Board J905-2
- J1-2 Black-Blue from Fliptronic II Board J905-5
- J1-3 N/C
- J1-4 Orange from Fliptronic II Board J905-6
- J1-5 N/C
- J1-6 Gray-Yellow from Fliptronic II Board J904-2
- J1-7 Gray-Yellow from Fliptronic II Board J904-2

Right Side Flipper Cabinet Opto Switch Board

- J1-1 Black-Yellow from Fliptronic II Board J905-1
- J1-2 Blue-Violet from Fliptronic II Board J905-3
- J1-3 Orange from Fliptronic II Board J905-6
- J1-4 Orange from Left Flipper Opto Assembly J1-4
- J1-5 N/C
- J1-6 Gray-Yellow from Left Flipper Opto Assembly J1-6
- J1-7 N/C

**A-16908
LED PCB Assembly
(green board)**

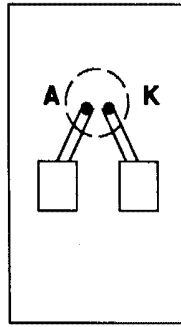

solder side

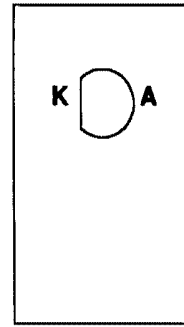

component side

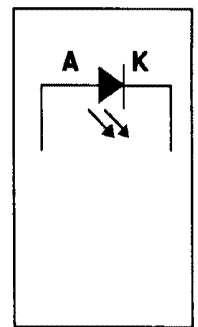

schematic

**A-16909
Photo Transistor PCB Assembly
(blue board)**

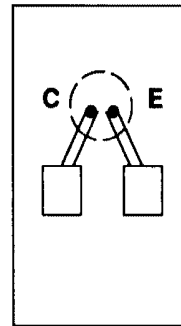

solder side

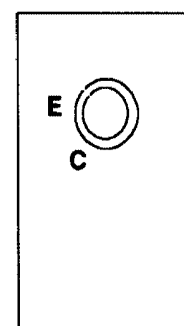

component side

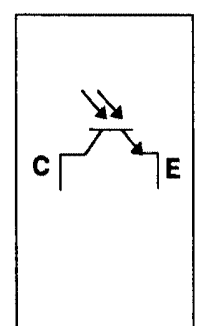

schematic

**Typical Circuit
Schematic**

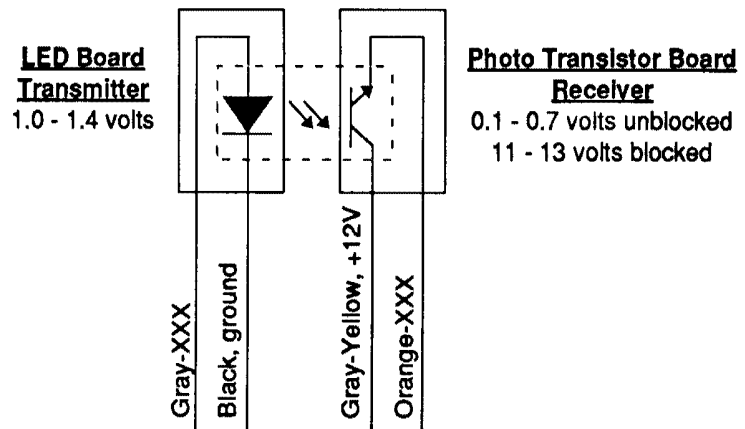

**Typical Circuit
Diagram**

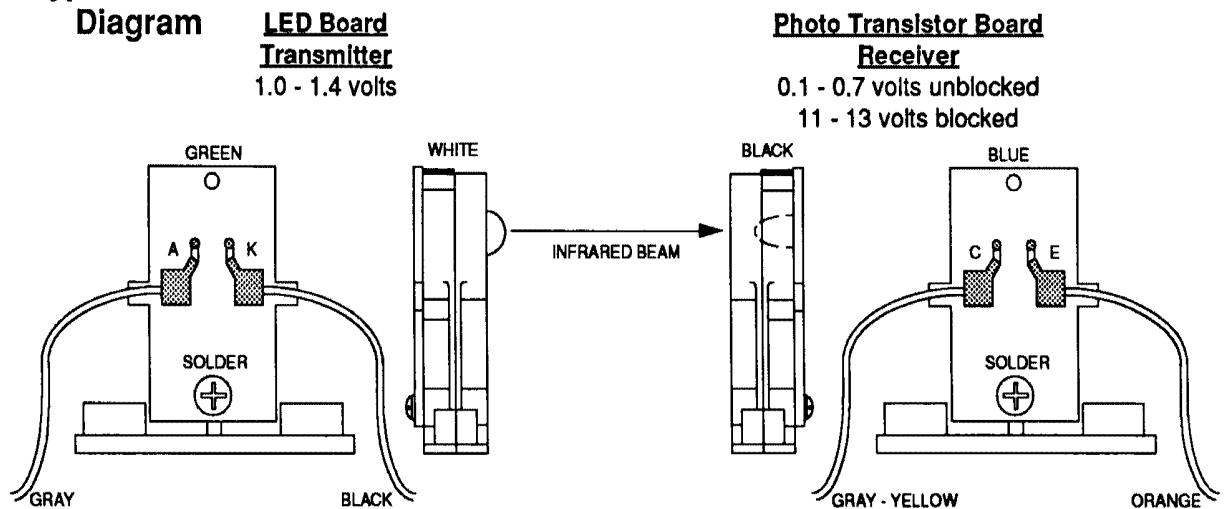

A-17981

7 Ball Trough Photo Transistor PCB Assembly

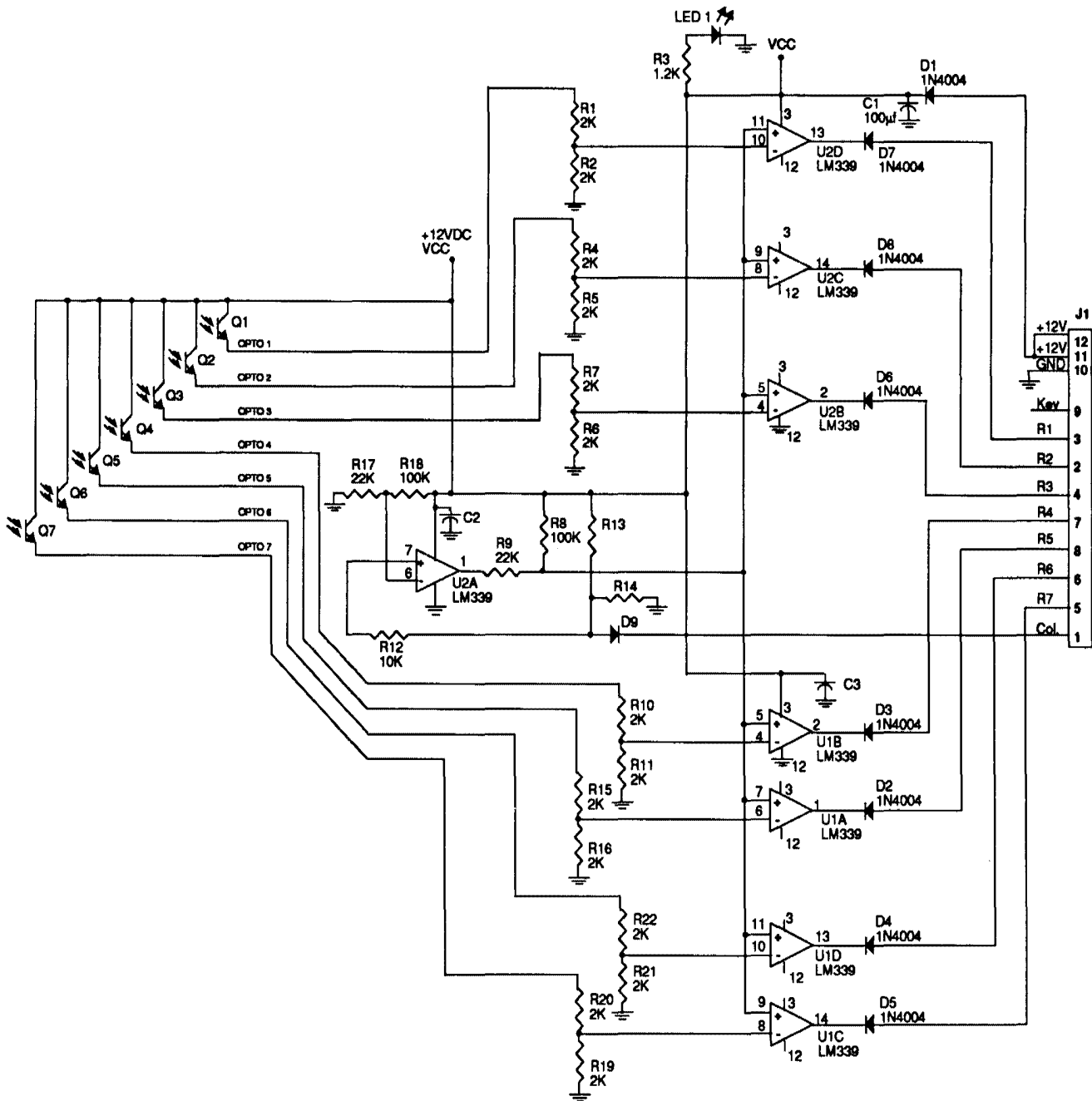
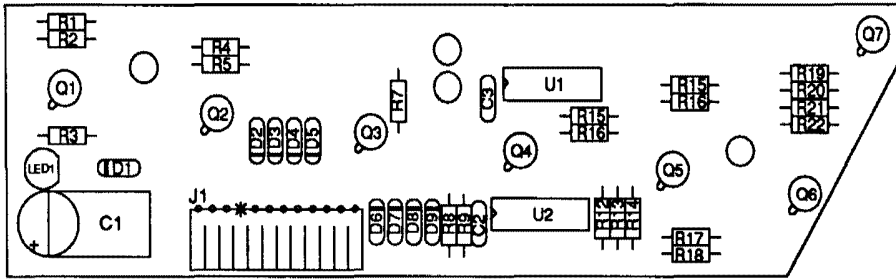

A-17982
7 Ball Trough LED PCB Assembly

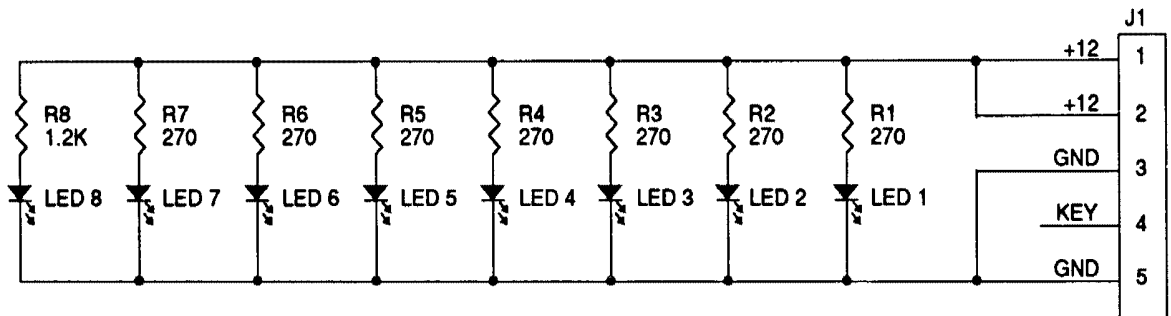
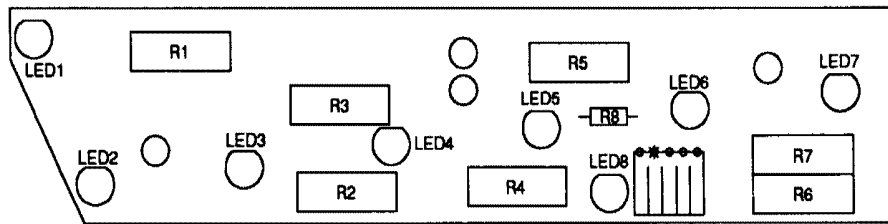

7 Ball Trough LED PCB Assembly

Connector Wiring

- J1-1 N/C
- J1-2 Gray-Yellow, +12V from Power Driver Board J118-2
- J1-3 N/C
- J1-4 Key
- J1-5 Black, ground from Power Driver Board J118-3

7 Ball Trough Photo Transistor PCB Assembly

Connector Wiring

- J1-1 Green-Orange, sw. col. 3 from CPU Board J207-3
- J1-2 White-Green, sw. row 5 from CPU Board J209-5
- J1-3 N/C
- J1-4 White-Yellow, sw. row 4 from CPU Board J209-4
- J1-5 White-Blue, sw. row 6 from CPU Board J209-7
- J1-6 White-Brown, sw. row 1 from CPU Board J209-1
- J1-7 White-Orange, sw. row 3 from CPU Board J209-3
- J1-8 White-Red, sw. row 2 from CPU Board J209-2
- J1-9 Key
- J1-10 Black, ground from Power Driver Board J118-3
- J1-11 N/C
- J1-12 Gray-Yellow, +12V from Power Driver Board J118-2

A-15576

7-Opto Switch Board Assembly

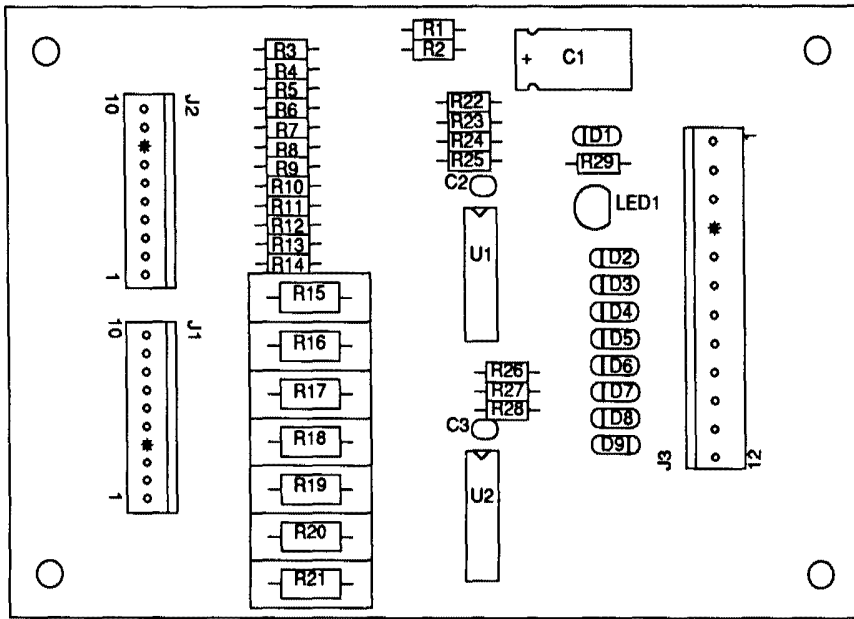

- J1 - 1 N/C
- J1 - 2 Gray-Blue (switch #76) to Bottom Popper Opto LED Brd.
- J1 - 3 N/C
- J1 - 4 Key
- J1 - 5 Gray-Black (switch #74) to Elevator Hold Opto LED Brd.
- J1 - 6 Gray-Orange (switch #73) to Top Popper Opto LED Brd
- J1 - 7 Gray-Red (switch #72) to Chase Car 2 Opto LED Brd.
- J1 - 8 Gray-Brown (switch #71) to Chase Car 1 Opto LED Brd.
- J1 - 9 N/C
- J1 - 10 Black (ground) to Opto LED Brds.

- J2 - 1 N/C
- J2 - 2 Orange-Blue (switch #76) to Bottom Popper Photo Trans Brd.
- J2 - 3 N/C
- J2 - 4 Orange-Yellow (switch #74) to Elevator Hold Photo Trans Brd.
- J2 - 5 Orange-Black (switch #73) to Top Popper Photo Trans Brd.
- J2 - 6 Orange-Red (switch #72) to Chase Car 2 Photo Trans Brd.
- J2 - 7 Orange-Brown (switch #71) to Chase Car 1 Photo Trans Brd.
- J2 - 8 Key
- J2 - 9 N/C
- J2 - 10 Gray-Yellow (+12V) to Photo Trans Brds.

- J3 - 1 Gray-Yellow (+12V) from Power Driver Board J118-2
- J3 - 2 N/C
- J3 - 3 Black (ground) from Power Driver Board J118-3
- J3 - 4 Key
- J3 - 5 White-Brown (switch row 1) from CPU J209-1
- J3 - 6 White-Red (switch row 2) from CPU J209-2
- J3 - 7 White-Orange (switch row 3) from CPU J209-3
- J3 - 8 White-Yellow (switch row 4) from CPU J209-4
- J3 - 9 N/C
- J3 - 10 White-Blue (switch row 6) from CPU J209-7
- J3 - 11 N/C
- J3 - 12 Green-Violet (switch column 7) from CPU J207-7

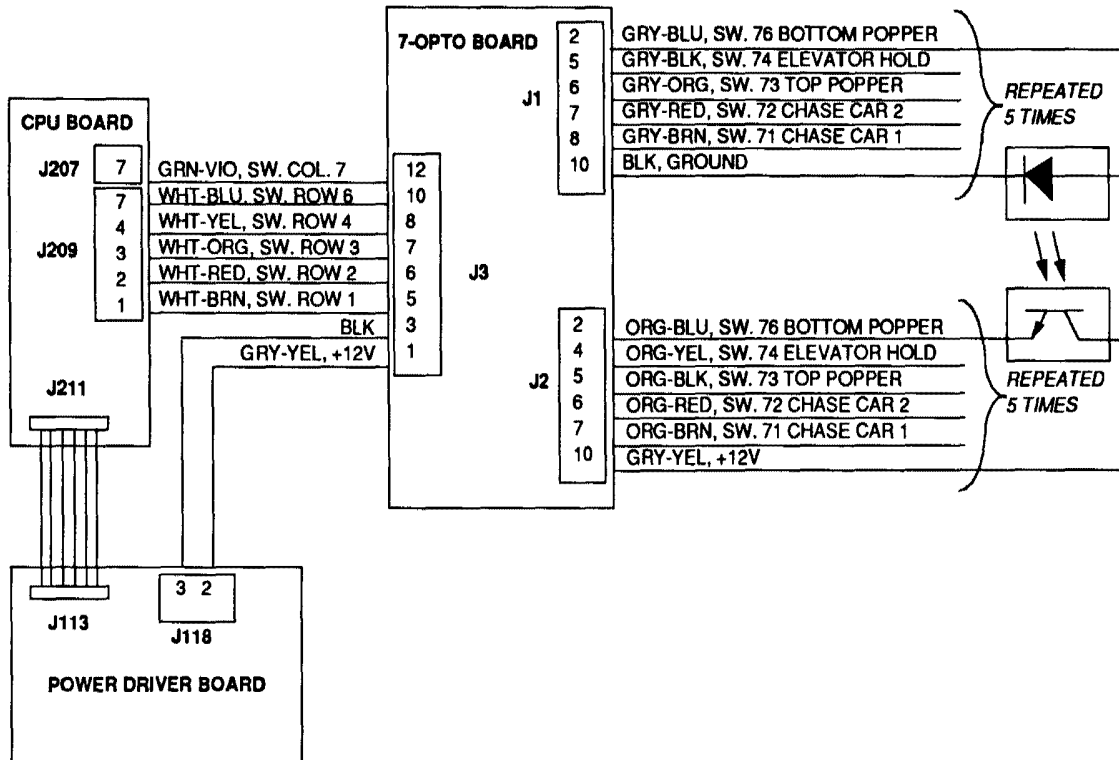

A-15576 7-Opto Switch Board Schematic

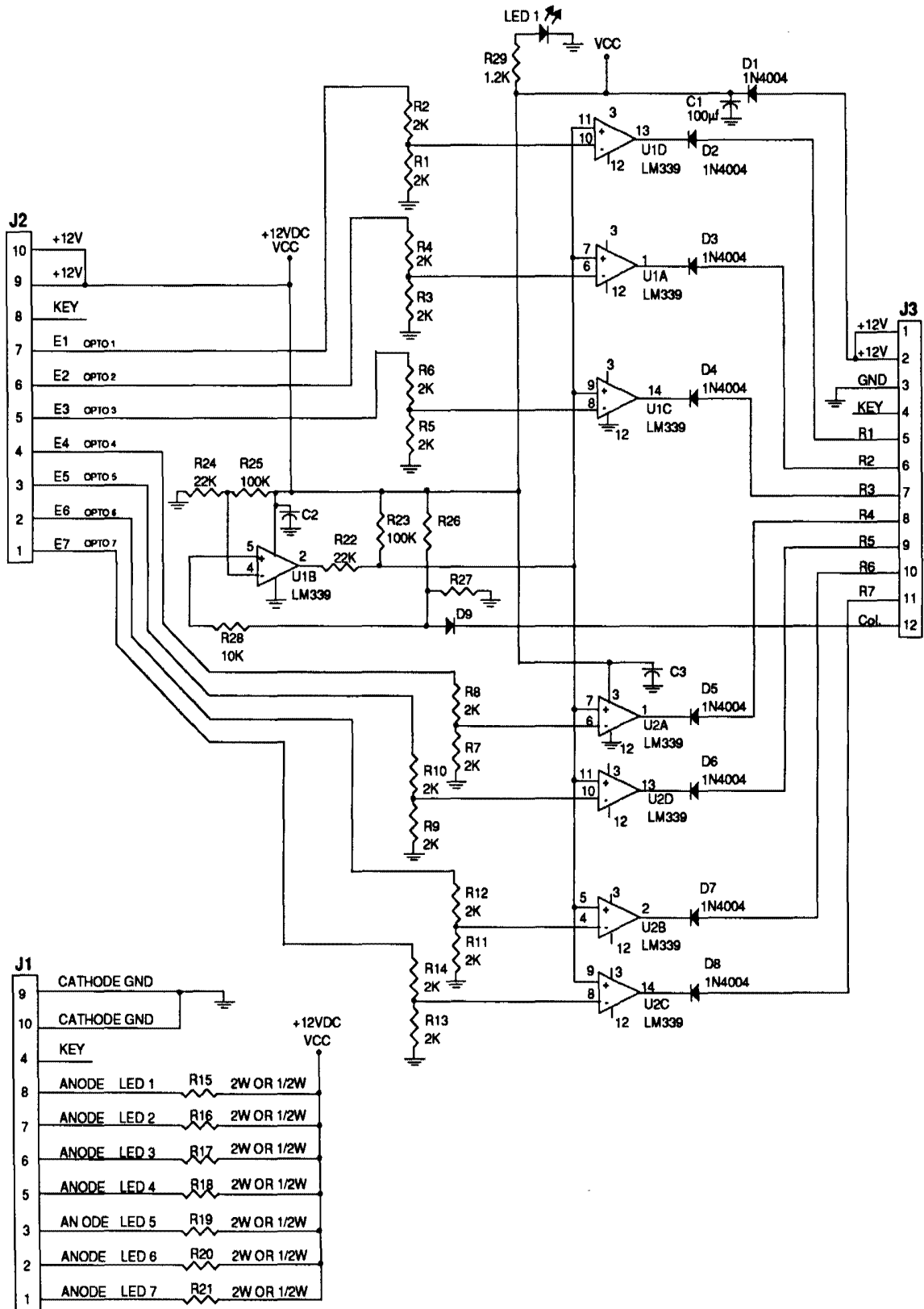

A-16986 Cryoclaw Opto PCB Assembly

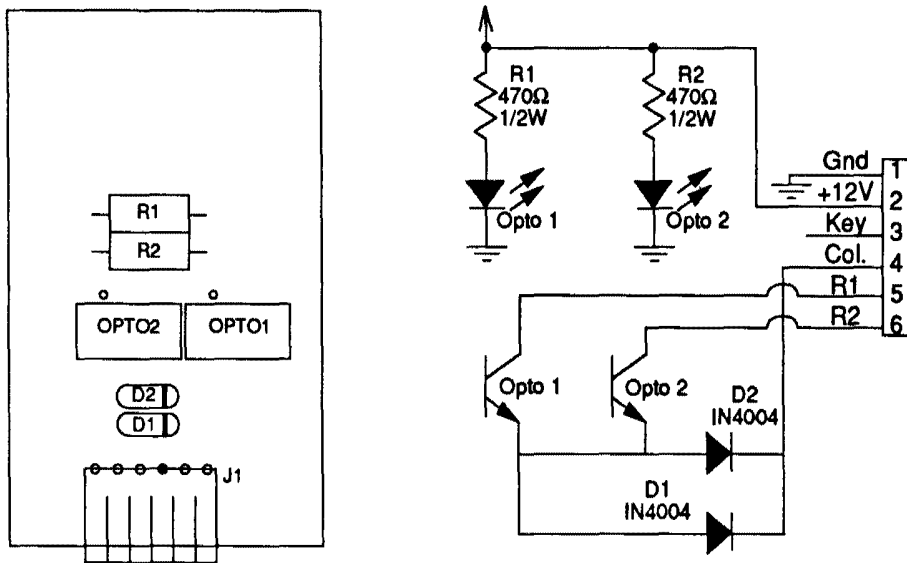

- J1 - 1 Black, ground from Power Driver Board J118-3
- J1 - 2 Gray-Yellow, +12V from Power Driver Board J118-2
- J1 - 3 Key
- J1 - 4 Green-Red, switch column 2 from CPU Board J207-2
- J1 - 5 White-Green, switch row 5 from CPU Board J209-5
- J1 - 6 White-Blue, switch row 6 from CPU Board J209-7

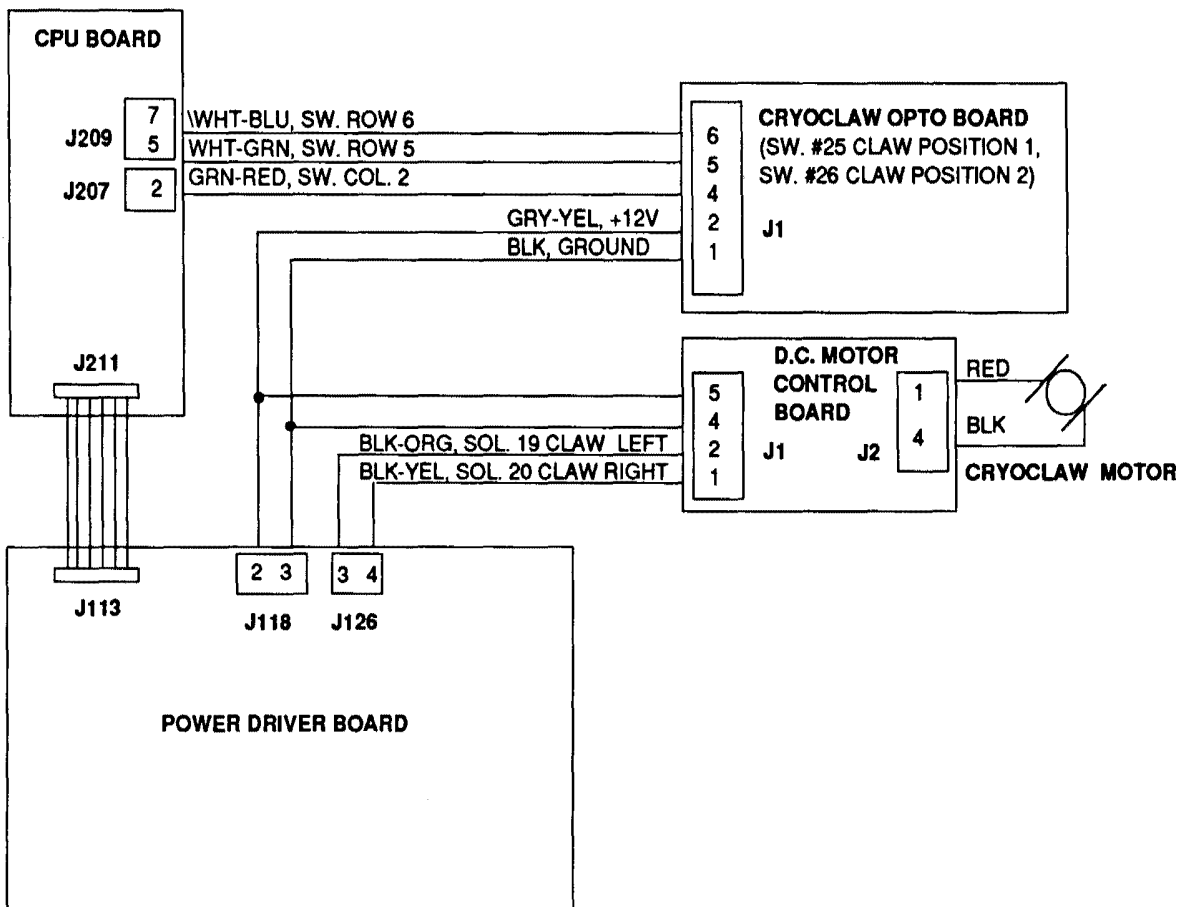

D.C. Motor Control Assembly A-16120

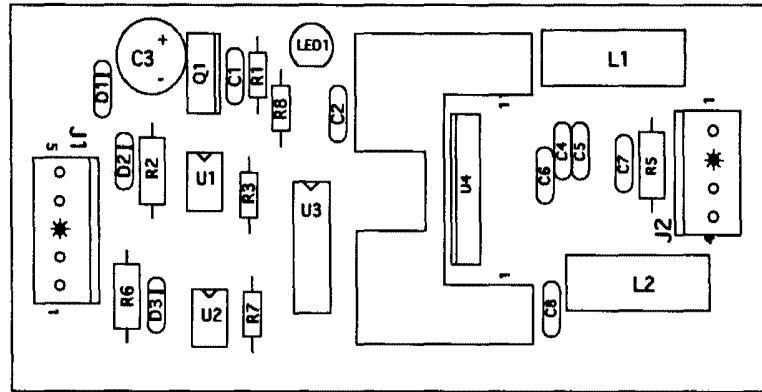

- | | |
|---|---------------------------------|
| J1 - 1 Black-Yellow, sol. 20 Claw Motor Right, from Power Driver Board J126-4 | J2 - 1 Red, to Cryoclaw Motor |
| J1 - 2 Black-Orange, sol. 19 Claw Motor Left, from Power Driver Board J126-3 | J2 - 2 Key |
| J1 - 3 Key | J2 - 3 Not Used |
| J1 - 4 Black, Ground from J118-3 | J2 - 4 Black, to Cryoclaw Motor |
| J1 - 5 Gray-Yellow, +12VDC from J118-2 | |

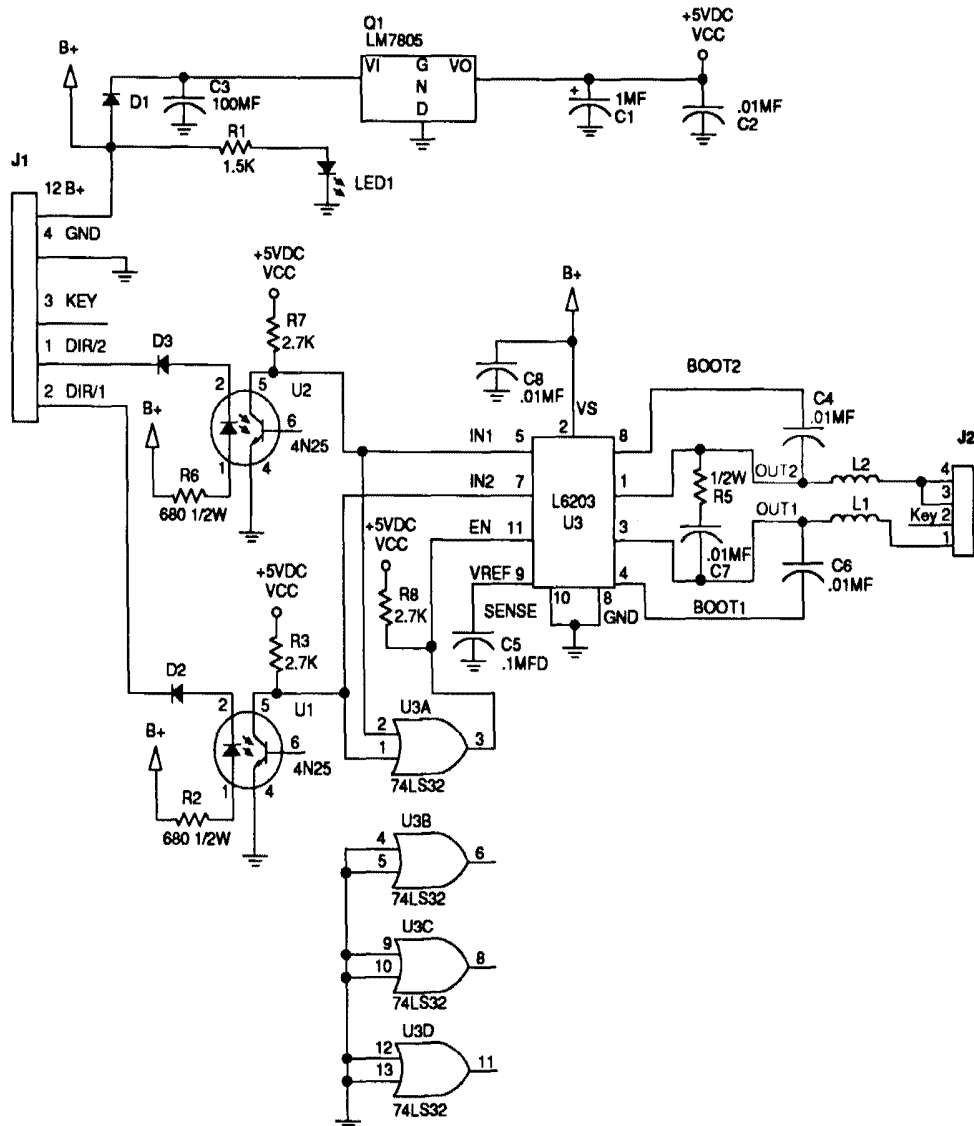

A-17596 Elevator Opto PCB Assembly

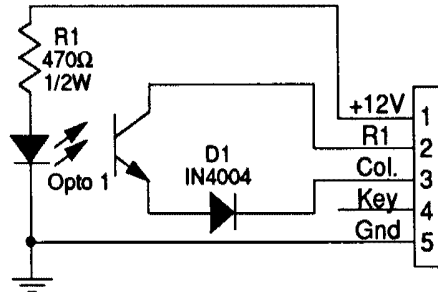
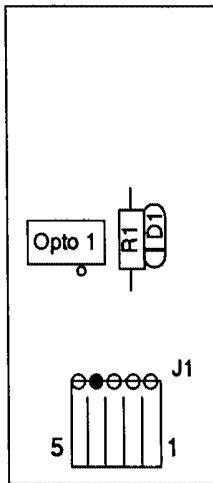

- J1 - 1 Gray-Yellow, +12V from Power Driver Board J118-2
- J1 - 2 White-Violet, switch row 7 from CPU Board J209-8
- J1 - 3 Green-Blue, switch column 6 from CPU Board J207-6
- J1 - 4 N/C
- J1 - 5 Black, ground from Power Driver Board J118-3

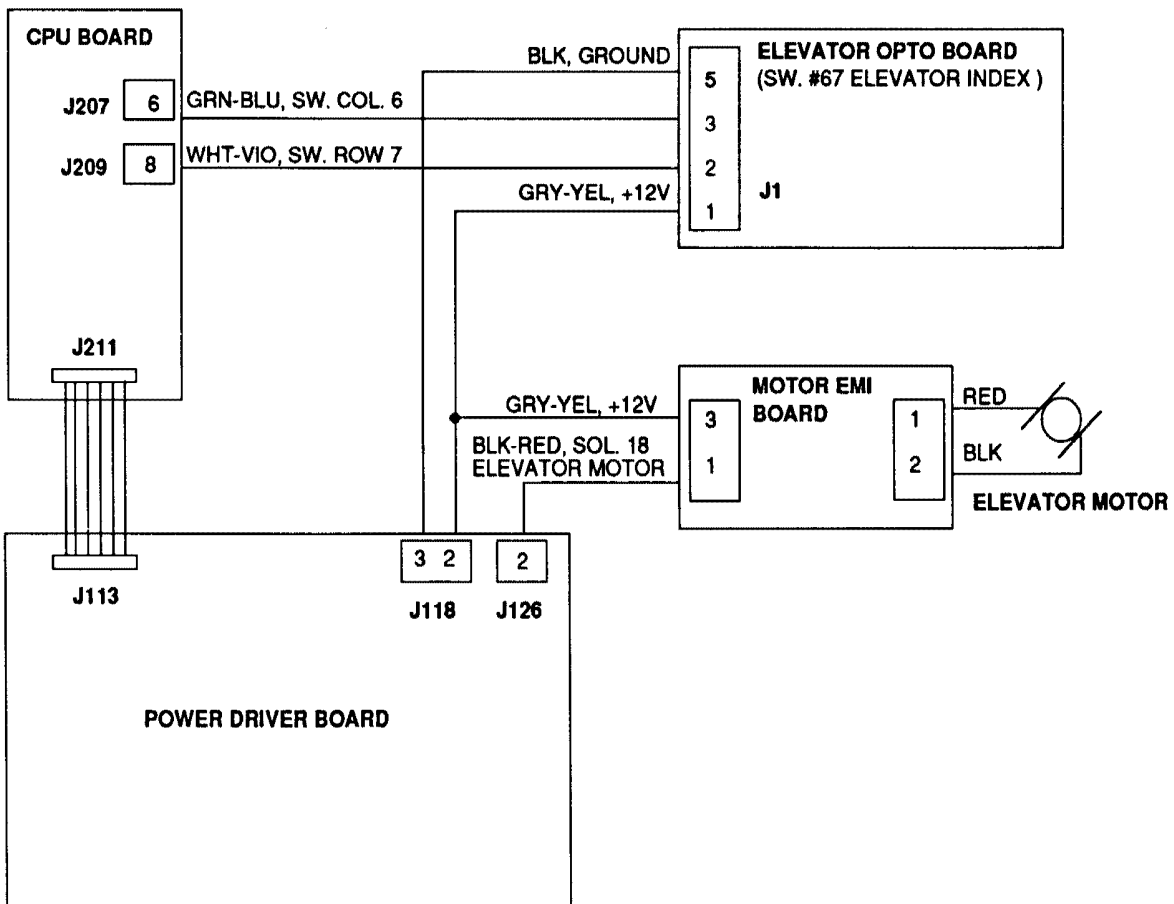

**A-15542
Motor EMI PCB Assembly**

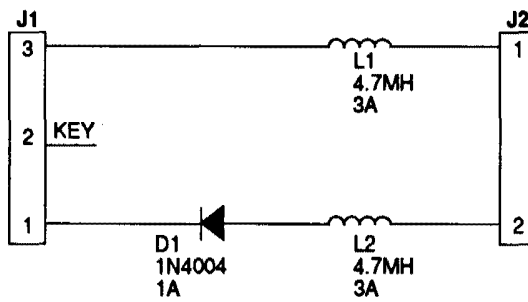
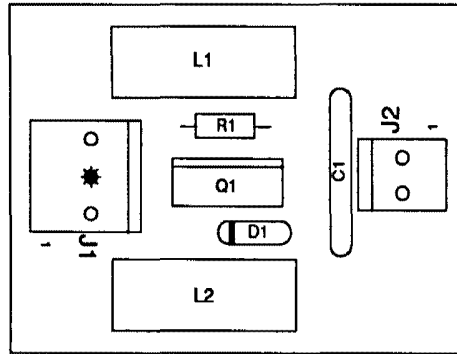

- J1 - 1** Black-Red, sol. 18 Elevator Motor, from Power Driver Board J126-2
- J1 - 2** Key
- J1 - 3** Gray-Yellow, +12V from Power Driver Board J118-2
- J2 - 1** Red to Elevator Motor
- J2 - 2** Black to Elevator Motor

A-16100-2 8-Driver (Aux. Driver) PCB Assembly

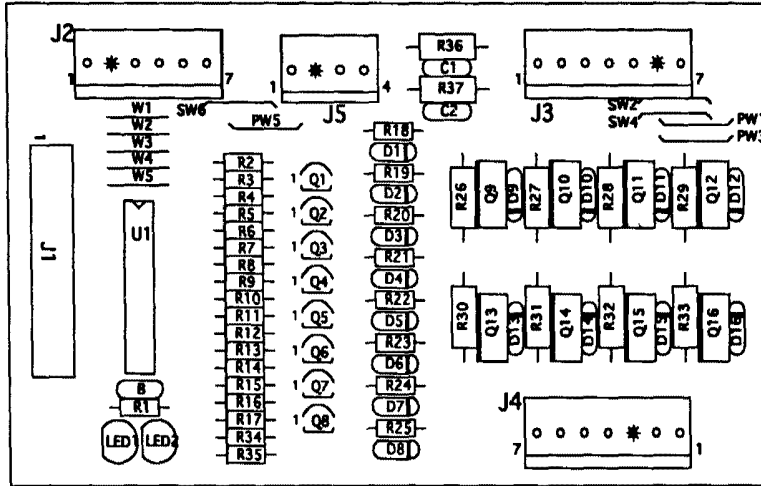

- | | |
|--|---|
| J1-1 Ribbon cable, data, from CPU Board J204 | J4-1 N/C |
| J2-1 Black-White, digital ground, from Power Driver Board J114-7 | J4-2 Brown-White, sol. 37 Car Chase Upper Flasher, to playfield |
| J2-2 Key | J4-3 N/C |
| J2-3 Gray, +5V, from Power Driver Board J114-3 | J4-4 Black-White, sol. 38 Lower Rebound Flasher, to playfield |
| J2-4 Black, ground, from Power Driver Board J103-1 | J4-5 Orange-White, sol. 39 Eyeball Flasher, to playfield |
| J2-5 Black, ground, from Power Driver Board J103-2 | J4-6 Yellow-White, sol. 40 Center Ramp Flasher, to playfield |
| J2-6 Gray-Green, +12V, from Power Driver Board J114-2 | J4-7 N/C |
| J3-1 N/C | J5-1 N/C |
| J3-2 Green-White, sol. 41 Elevator 2 Flasher, to playfield | J5-2 Key |
| J3-3 Blue-White, sol. 42 Elevator 1 Flasher, to playfield | J5-3 N/C |
| J3-4 Violet-White, sol. 43 Diverter Flasher, to playfield | J5-4 N/C |
| J3-5 Gray-White, sol. 44 Right Ramp Upper Flasher, to playfield | |
| J3-6 Key | |
| J3-7 N/C | |

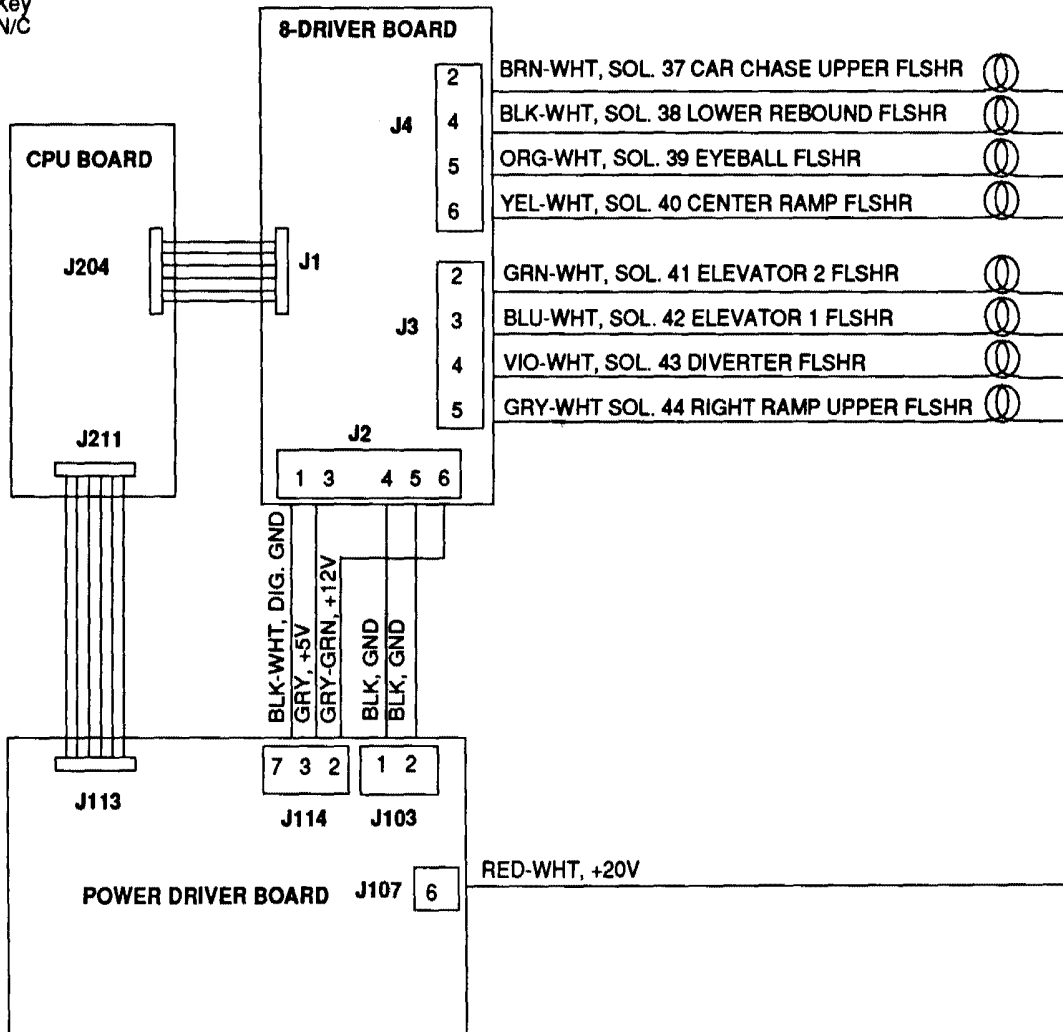

DEMOLITION MAN 3-25

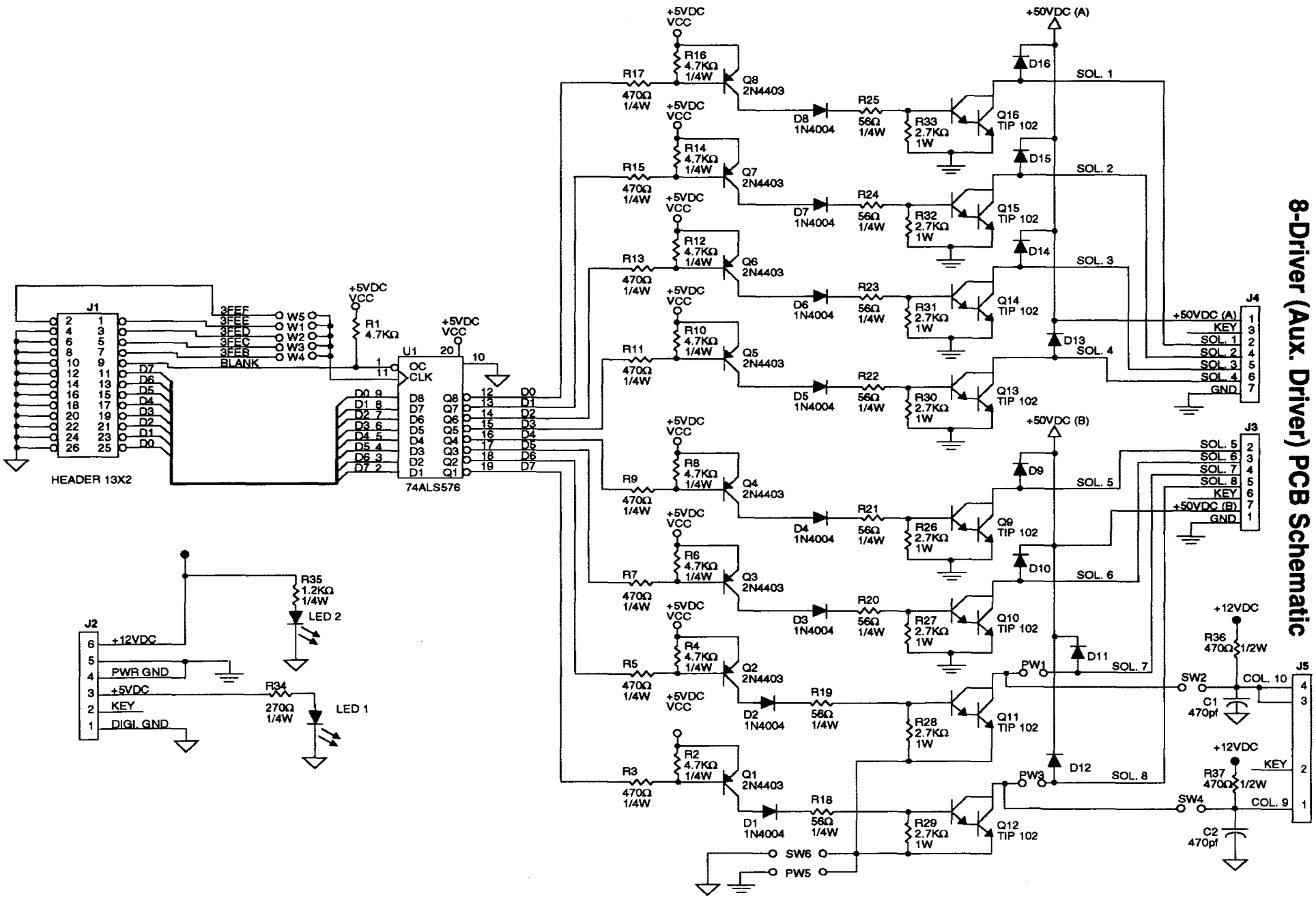

8-Driver (Aux. Driver) PCB Schematic
A-16100-2

A-17051-1 Coin Door Interface PCB Assembly

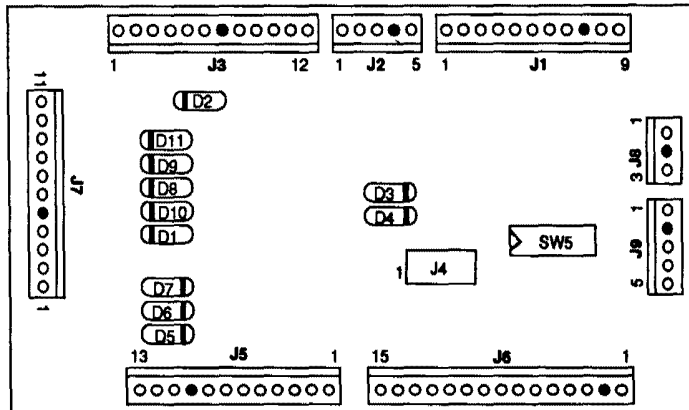

J1-1 Orange-Gray, dedicated row 8 from CPU J205-9
 J1-2 Orange-Violet, dedicated row 7 from CPU J205-8
 J1-3 Orange-Blue, dedicated row 6 from CPU J205-7
 J1-4 Orange-Green, dedicated row 5 from CPU J205-6
 J1-5 Orange-Yellow, dedicated row 4 from CPU J205-4
 J1-6 Orange-Black, dedicated row 3 from CPU J205-3
 J1-7 Orange-Red, dedicated row 2 from CPU J205-2
 J1-8 Orange-Brown, dedicated row 1 from CPU J205-1
 J1-9 N/C
 J1-10 Black, ground from CPU J205-10
 J1-11 Orange-White, sw. enable from J205-12

J2-1 Black, ground from Power Driver Brd J116-3
 J2-2 Gray-Yellow, +12vac from Power Driver Brd J116-2
 J2-3 White-Violet, G.I. 6.8vac from Power Driver Brd J119-1
 J2-4 N/C
 J2-5 Violet, G.I. from Power Driver Brd J119-3

J3-1 Green-Brown, sw. col. 1 from CPU J212-1
 J3-2 Green-Red, sw. col. 2 from CPU J212-2
 J3-3 White-Brown, sw. row 1 from J212-4
 J3-4 White-Red, sw. row 2 from CPU J212-6
 J3-5 White-Orange, sw. row 3 from CPU J212-7
 J3-6 White-Yellow, sw. row 4 from CPU J212-8
 J3-7 N/C
 J3-8 Yellow-Gray, lamp col. 8 from Power Driver Brd J136-3
 J3-9 Red-Blue, lamp row 6 from Power Driver Brd J133-7
 J3-10 Red-Violet, lamp row 7 from Power Driver Brd J133-8
 J3-11 Red-Gray, lamp row 8 from Power Driver Brd J133-9
 J3-12 N/C

J4- not used

J5-1 Violet, G.I. return to coin door
 J5-2 White-Violet, G.I. 6.8vac to coin door
 J5-3 Black, ground to coin door
 J5-4 Orange-Brown, dedicated sw. row 1 to coin door
 J5-5 Orange-Red, dedicated sw. row 2 to coin door
 J5-6 Orange-Black, dedicated sw. row 3 to coin door
 J5-7 Orange-Green, dedicated sw. row 5 to coin door
 J5-8 Orange-Blue, dedicated sw. row 6 to coin door
 J5-9 Orange-Violet, dedicated sw. row 7 to coin door
 J5-10 N/C
 J5-11 Orange-Gray, dedicated sw. row 8 to coin door
 J5-12 Green-Red, sw. col. 2 to coin door Slam tilt
 J5-13 White-Brown, sw. row 1 to coin door Slam tilt

J6- not used

J7-1 Yellow-Gray, lamp col. 8 to cabinet
 J7-2 Red-Blue, lamp row 6 to cabinet
 J7-3 Red-Violet, lamp row 7 to cabinet
 J7-4 Red-Gray, lamp row 8 to cabinet
 J7-5 N/C
 J7-6 Green-Brown, sw. col. 1 to cabinet
 J7-7 Green-Red, sw. col. 2 to cabinet
 J7-8 White-Orange, sw. row 3 to cabinet
 J7-9 White-Red, sw. row 2 to cabinet
 J7-10 White-Brown, sw. row 1 to cabinet
 J7-11 White-Orange, sw. row 3 to cabinet

J8-1 White, sw. row to cabinet Slam tilt
 J8-2 N/C
 J8-3 Green, sw. col to cabinet Slam tilt

J9-1 White-Yellow, sw. row 4 to Plumb Bob tilt
 J9-2 N/C
 J9-3 Green-Brown, sw. col. 1 to Plumb Bob tilt
 J9-4 White-Red, sw. row 2 to interlock switch
 J9-5 Green-Red, sw. col. 2 to interlock switch

A-17051-1 Coin Door Interface PCB Schematic

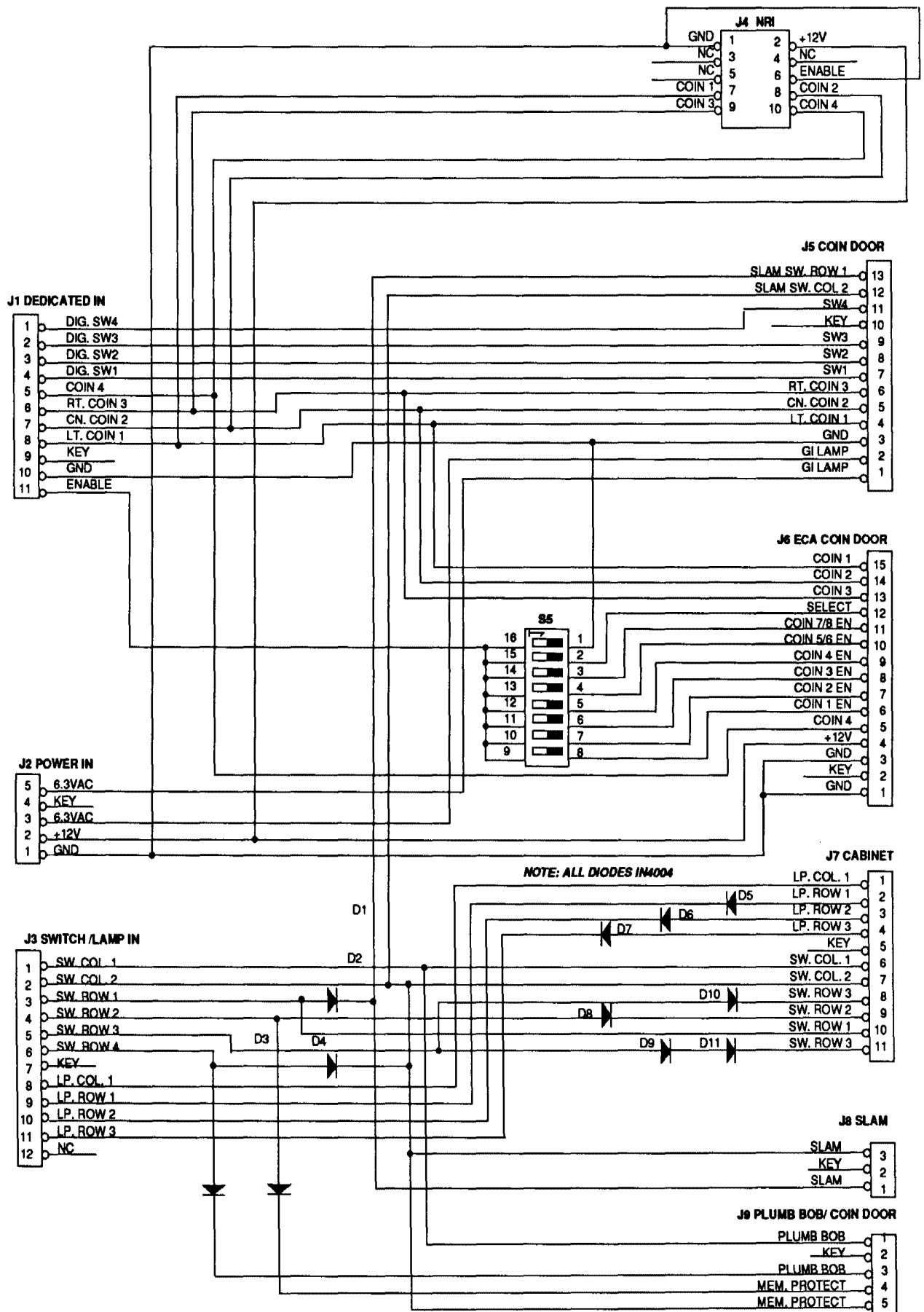

A-16917-50028 Sound Board

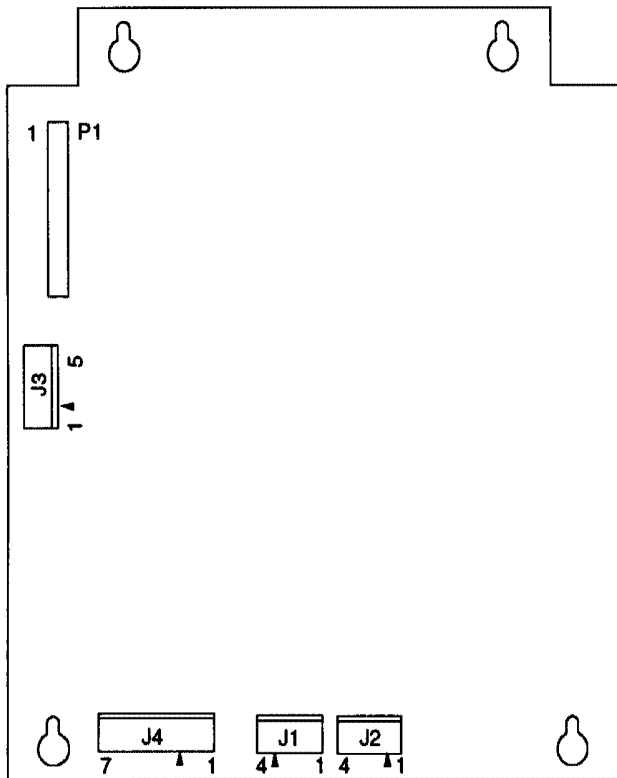

P1, 34-pin Ribbon Cable, data, To/from J601; J903; J202

J1-1 Black-Yellow, signal to speaker
J1-2 N/C
J1-3 N/C
J1-4 Black-Yellow, signal to speaker

J2-1 Black-Yellow, signal to speaker
J2-2 N/C
J2-3 N/C
J2-4 Black-Yellow, signal to speaker

J3-1 Gray, +5V, from Power Driver Board J114-3,4
J3-2 N/C
J3-3 Gray, +5V, from Power Driver Board J114-3,4
J3-4 Black, ground, from Power Driver Board J114-5,7
J3-5 Black, ground, from Power Driver Board J114-5,7

J4-1 Gray-Green, 18VAC, from xformer secondary
J4-2 Gray-Green, 18VAC, loop from J4-1
J4-3 N/C
J4-4 Gray, 18VAC, from xformer secondary
J4-5 Gray, 18VAC, loop from J4-4
J4-6 Gray-White, 18VAC, from xformer secondary
J4-7 Gray-White, 18VAC, loop from J4-6

SPEAKER WIRING DIAGRAM

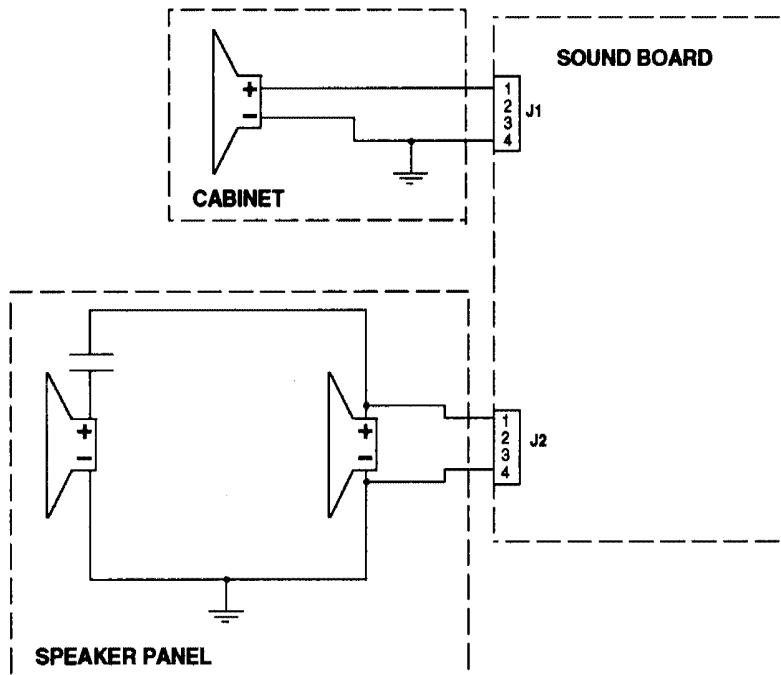

A-12742-50028 CPU Board

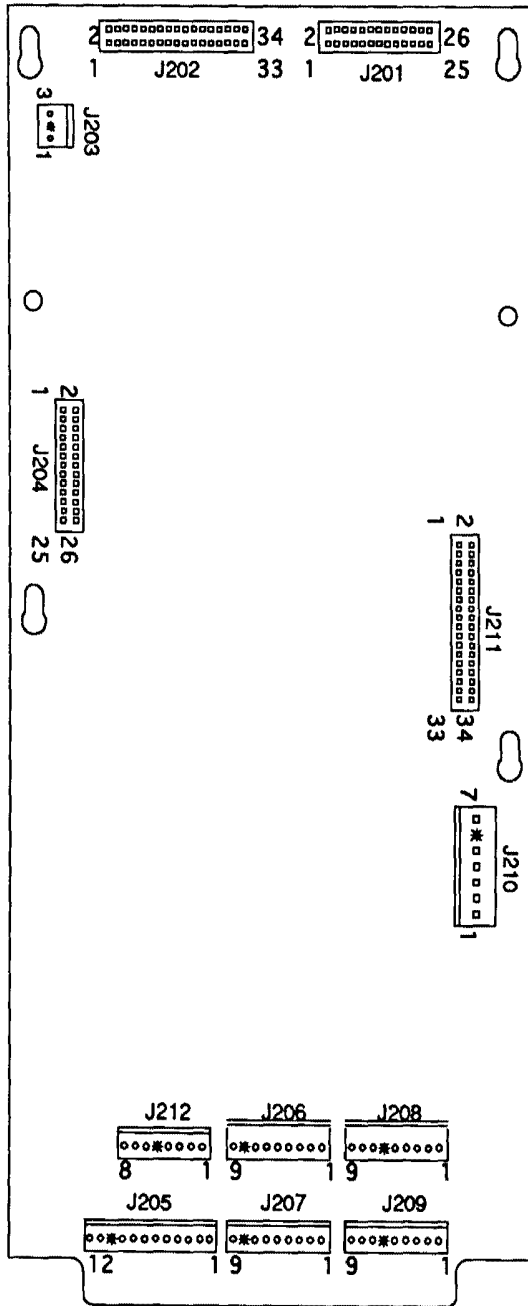

- J206-1 N/C
- J206-2 N/C
- J206-3 N/C
- J206-4 N/C
- J206-5 N/C
- J206-6 N/C
- J206-7 N/C
- J206-8 N/C
- J206-9 N/C

- J207-1 Green-Brown, sw. col. 1, to playfield switches
- J207-2 Green-Red, sw. col. 2, to playfield/cabinet switches
- J207-3 Green-Orange, sw. col. 3, to playfield switches
- J207-4 Green-Yellow, sw. col. 4, to playfield switches
- J207-5 Green-Black, sw. col. 5, to playfield switches
- J207-6 Green-Blue, sw. col. 6, to playfield switches
- J207-7 Green-Violet, sw. col. 7, to playfield switches
- J207-8 N/C
- J207-9 Green-Gray, sw. col. 8, to playfield switches

- J208-1 N/C
- J208-2 N/C
- J208-3 N/C
- J208-4 N/C
- J208-5 N/C
- J208-6 N/C
- J208-7 N/C
- J208-8 N/C
- J208-9 N/C

- J209-1 White-Brown, sw. row 1, to playfield switches
- J209-2 White-Red, sw. row 2, to playfield switches
- J209-3 White-Orange, sw. row 3, to playfield switches
- J209-4 White-Yellow, sw. row 4, to playfield switches
- J209-5 White-Green, sw. row 5, to playfield switches
- J209-6 N/C
- J209-7 White-Blue, sw. row 6, to playfield switches
- J209-8 White-Violet, sw. row 7, to playfield switches
- J209-9 White-Gray, sw. row 8, to playfield switches

- J210-1 Black, ground, from Power Driver Brd J114-5,7
- J210-2 N/C
- J210-3 Black, ground, from Power Driver Brd J114-5,7
- J210-4 Gray, +5V, from Power Driver Brd J114-3,4
- J210-5 Gray, +5V, from Power Driver Brd J114-3,4
- J210-6 Gray-Green, +12V, from Power Driver Brd J114-1,2
- J210-7 Gray-Green, +12V, from Power Driver Brd J114-1,2

- J211, 34-pin Ribbon Cable, data, To/from J113

- J201, 26-pin Ribbon Cable, data, To/from J602
- J202, 34-pin Ribbon Cable, data, To/from J903; P1; J601
- J203-Not Used
- J204, 26-pin Ribbon Cable, data To/from 8-Driver Board J1
- J205 - 1 Orange-Brown, ded. sw. row 1, to Coin Door Brd J1-8
- J205 - 2 Orange-Red, ded. sw. row 2, to Coin Door Brd J1-7
- J205 - 3 Orange-Black, ded. sw. row 3, to Coin Door Brd J1-6
- J205 - 4 Orange-Yellow, ded. sw. row 4, to Coin Door J1-5
- J205 - 5 N/C
- J205 - 6 Orange-Green, ded. sw. row 5, to Coin Door Brd J1-4
- J205 - 7 Orange-Blue, ded. sw. row 6, to Coin Door Brd J1-3
- J205 - 8 Orange-Violet, ded. sw. row 7, to Coin Door Brd J1-2
- J205 - 9 Orange-Gray, ded. sw. row 8, to Coin Door Brd J1-1
- J205 - 10 Black, ground, to Coin Door Brd J1-10
- J205 - 11 N/C
- J205 - 12 Orange-White, sw. enable, to Coin Door Brd J1-11

- J212-1 Green-Brown, sw. col. 1, to Coin Door Brd J3-1
- J212-2 Green-Red, sw. col. 2, to Coin Door J3-2
- J212-3 N/C
- J212-4 White-Brown, sw. row 1, to Coin Door Brd J3-3
- J212-5 N/C
- J212-6 White-Red, sw. row 2, to Coin Door Brd J3-4
- J212-7 White-Orange, sw. row 3, Coin Door Brd J3-5
- J212-8 White-Yellow, sw. row 4, to Coin Door Brd J3-6

A-14039 Dot Matrix Controller Board

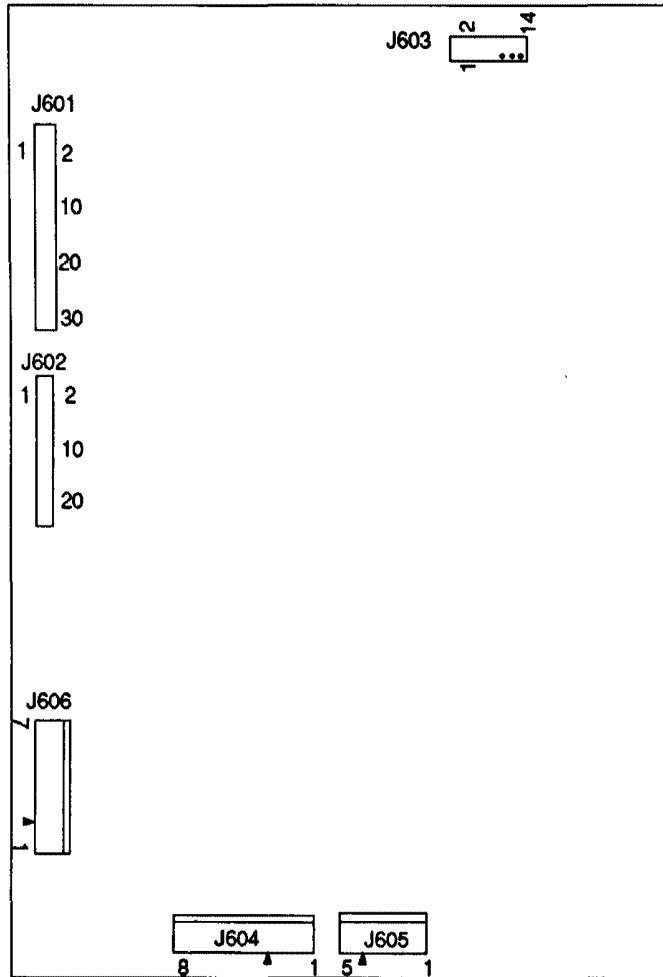

J601, 34-pin Ribbon Cable data, To/from J202; J903; P1

J602, 26-pin Ribbon Cable data, To/from J201

J603, 14-pin Ribbon Cable data, To/from Dot Matrix Display/Driver

J604-1 Orange, -125V, to Display/Driver pin 1

J604-2 Blue, -113V, to Display/Driver pin 2

J604-3 N/C

J604-4 Black, ground, to Display/Driver pin 4

J604-5 Black, ground, to Display/Driver pin 5

J604-6 Gray, +5V, to Display/Driver pin 6

J604-7 Gray-Yellow, +12V, to Display/Driver pin 7

J604-8 Brown, +62V, to Display/Driver pin 8

J605-1 White, 80VAC, from xformer secondary

J605-2 White, 80VAC, from xformer secondary

J605-3 Violet, 100VAC, from xformer secondary

J605-4 N/C

J605-5 Violet 100VAC, from xformer secondary

J606-1 Black, ground, loop from J606-3

J606-2 N/C

J606-3 Black, ground, from Power Driver Brd J117-3

J606-4 Gray, +5V, loop from J606-5

J606-5 Gray, +5V, from Power Driver Brd J117-4

J606-6 Gray-Yellow, +12V, loop from J606-7

J606-7 Gray-Yellow, +12V, from Power Driver Brd J117-2

A-15472-1 Fliptronic II Board

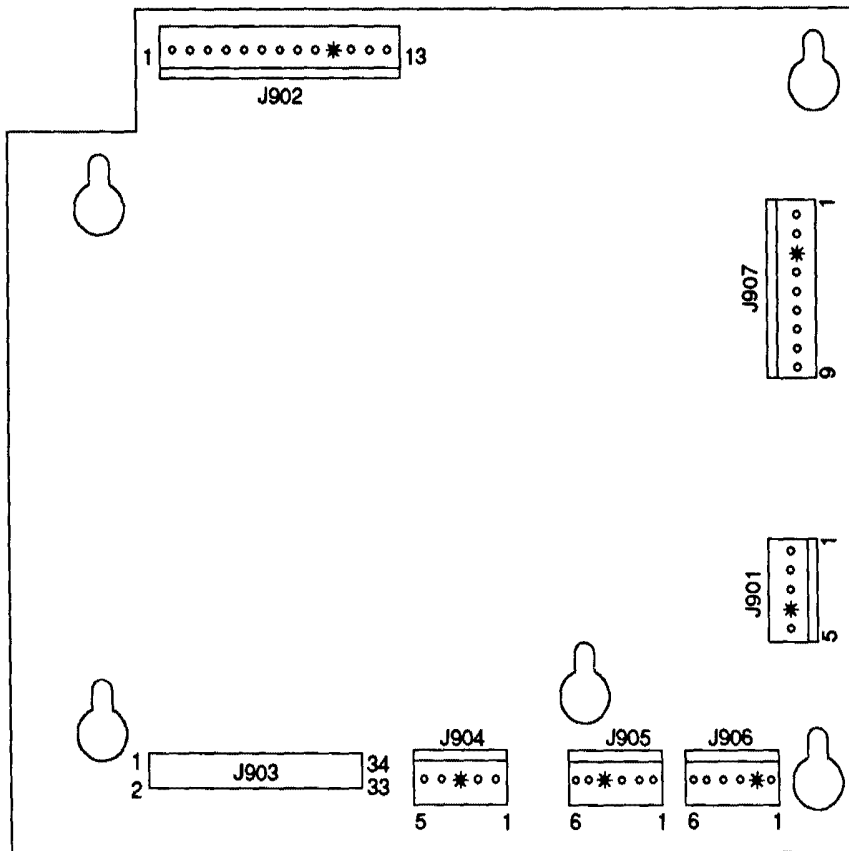

- | | |
|--|---|
| J901-1 White-Blue, 50VAC, from Power Driver Board J104-2 | J905-1 Blue-Violet, F2, to right flipper opto switch board J1-1 |
| J901-2 White-Blue, 50VAC, loop from J901-1 | J905-2 Blue-Gray, F4, to left flipper opto switch board J1-1 |
| J901-3 White-Blue, 50VAC, from Power Driver Board J104-1 | J905-3 Black-Yellow, F6, to right flipper opto switch board J1-2 |
| J901-4 N/C | J905-4 N/C |
| J901-5 White-Blue, 50VAC, loop from J901-3 | J905-5 Black-Blue, F8, to left flipper opto switch board J1-2 |
| J902-1 Orange-Gray, holding, upper left flipper coil | J905-6 Orange, ground, to left flipper opto switch board J1-3 |
| J902-2 N/C | J906-1 Black-Green, F1, to lower right EOS switch |
| J902-3 Yellow-Gray, power, upper left flipper coil | J906-2 N/C |
| J902-4 Orange-Violet, holding, upper right flipper coil | J906-3 Black-Blue, F3, to lower left EOS switch |
| J902-5 N/C | J906-4 Black-Violet, F5, to upper right EOS switch (not used) |
| J902-6 Yellow-Violet, power, upper right flipper coil | J906-5 Black-Gray, F7, to upper left EOS switch |
| J902-7 Orange-Blue, holding, lower left flipper coil | J906-6 Orange, ground, to EOS switches |
| J902-8 N/C | J907-1 Red-Green, +50V, to lower right flipper coil |
| J902-9 Yellow-Blue, power, lower left flipper coil | J907-2 Red-Green, +50V, loop from J907-1 |
| J902-10 N/C | J907-3 N/C |
| J902-11 Orange-Green, holding, lower right flipper coil | J907-4 Red-Blue, +50V to lower left flipper coil |
| J902-12 N/C | J907-5 Red-Blue, +50V loop from J907-4 |
| J902-13 Yellow-Green, power, lower right flipper coil | J907-6 Red-Violet, +50V, to upper right flipper coil |
| J903, 34-pin Ribbon Cable, data, To/from J202; J601; P1 | J907-7 Red-Violet, +50V, loop from J907-6 |
| J904-1 Gray, +5V, from Power Driver Board J114-3,4 | J907-8 Red-Gray, +50V, to upper left flipper coil |
| J904-2 Gray-Green, +12V, from Power Driver Board J114-1,2 | J907-9 Red-Gray, +50V, loop from J907-8 |
| J904-3 N/C | |
| J904-4 Black, ground, from Power Driver Board J114-5,7 | |
| J904-5 Black, ground, from Power Driver Board J114-5,7 | |

A-12697-3 Power Driver Board

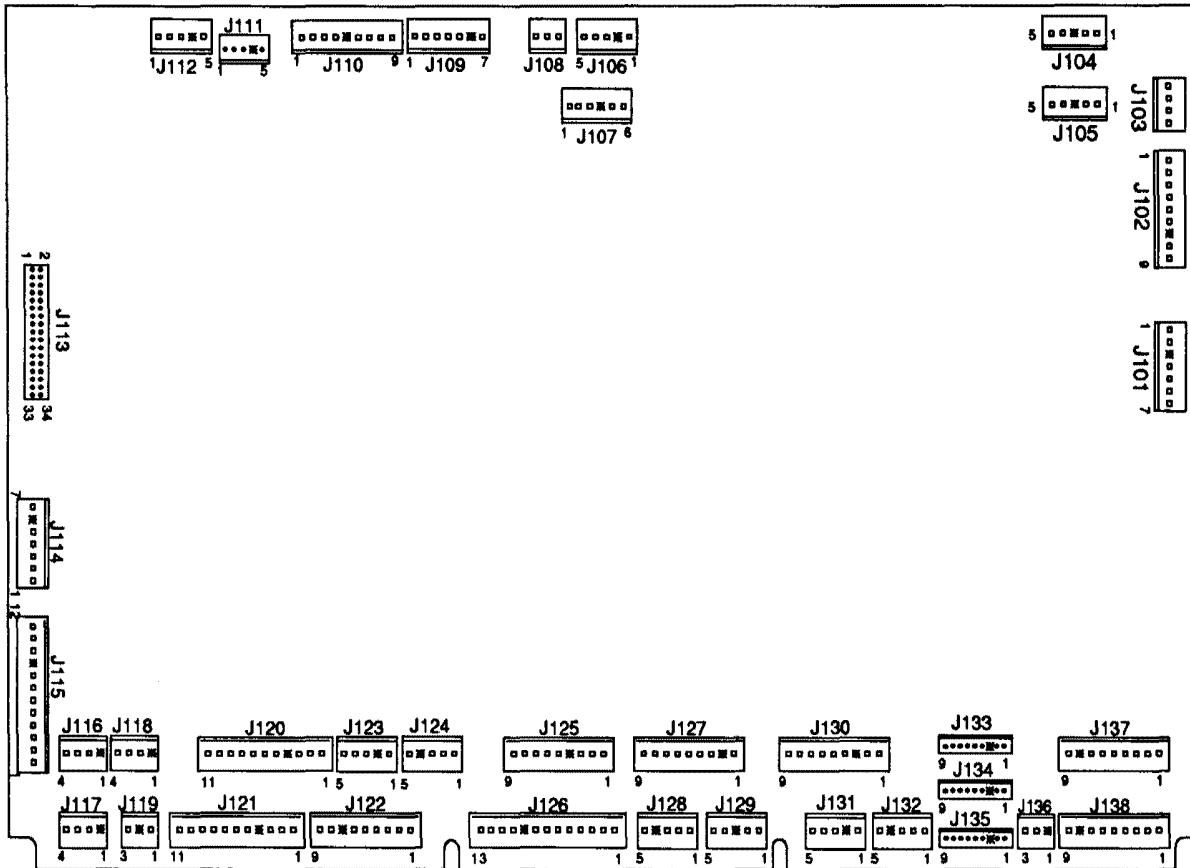

- | | |
|---|---|
| J101-1 Red, 9VAC, from xformer secondary | J105-1 N/C |
| J101-2 Red, 9VAC, from xformer secondary | J105-2 N/C |
| J101-3 N/C | J105-3 N/C |
| J101-4 Blue-White, 13VAC, from xformer secondary | J105-4 N/C |
| J101-5 Blue-White, 13VAC, loop from J101-4 | J105-5 N/C |
| J101-6 Blue-White, 13VAC, from xformer secondary | J106-1 N/C |
| J101-7 Blue-White, 13VAC, loop from J101-6 | J106-2 N/C |
| J102-1 White-Red, 16VAC, loop from J102-2 | J106-3 N/C |
| J102-2 White-Red, 16VAC, from xformer secondary | J106-4 N/C |
| J102-3 White-Red, 16VAC, loop from J102-4 | J106-5 Red-White, +20V, to backbox flashlamps |
| J102-4 White-Red, 16VAC, from xformer secondary | J107-1 N/C |
| J102-5 Black-Yellow, 16VAC, loop from J102-6 | J107-2 Red-Brown, +50V, to coils |
| J102-6 Black-Yellow, 16VAC, from xformer secondary | J107-3 Red-Black, +50V, to coils |
| J102-7 N/C | J107-4 N/C |
| J102-8 Black-Yellow, 16VAC, loop from J102-9 | J107-5 N/C |
| J102-9 Black-Yellow, 16VAC, from xformer secondary | J107-6 Red-White, +20V, to playfield |
| J103-1 Black, ground, to 8-Driver Brd J2-4 | J108-1 N/C |
| J103-2 Black, ground, to 8-Driver Brd J2-5 | J108-2 N/C |
| J103-3 N/C | J108-3 N/C |
| J103-4 N/C | J109-1 N/C |
| J104-1 White-Blue, 50VAC, to Fliptronic II Board J901-3 | J109-2 N/C |
| J104-2 White-Blue, 50VAC, to Fliptronic II Board J901-1 | J109-3 N/C |
| J104-3 N/C | J109-4 N/C |
| J104-4 N/C | J109-5 N/C |
| J104-5 N/C | J109-6 N/C |
| | J109-7 N/C |

Power Driver Board Continued...

J110-1	N/C	J119-1	White-Violet, 6.8VAC, G.I. to Coin Door Brd J2-2
J110-2	N/C	J119-2	N/C
J110-3	N/C	J119-3	Violet, return, G.I. to Coin Door Brd J2-1
J110-4	N/C		
J110-5	N/C		
J110-6	N/C	J120-1	Brown, return, G.I. to backbox
J110-7	N/C	J120-2	Orange, return, G.I. to backbox
J110-8	N/C	J120-3	Yellow, return, G.I. to backbox
J110-9	N/C	J120-4	N/C
		J120-5	Green, return, G.I. to backbox
J111-1	N/C	J120-6	Violet, return, G.I. to backbox
J111-2	N/C	J120-7	White-Brown, 6.8VAC, G.I. to backbox
J111-3	N/C	J120-8	White-Orange, 6.8VAC, G.I. to backbox
J111-4	N/C	J120-9	White-Yellow, 6.8VAC, G.I. to backbox
J111-5	N/C	J120-10	White-Green, 6.8VAC, G.I. to backbox
		J120-11	White-Violet, 6.8VAC, G.I. to backbox
J112-1	White-Green, 9.8VAC, from xformer secondary	J121-1	Brown, return, G.I. to playfield
J112-2	White-Green, 9.8VAC, loop from J112-1	J121-2	Orange, return, G.I. to playfield
J112-3	White-Green, 9.8VAC, from xformer secondary	J121-3	Yellow, return, G.I. to playfield
J112-4	N/C	J121-4	N/C
J112-5	White-Green, 9.8VAC, loop from J112-3	J121-5	Green, return, G.I. to playfield
		J121-6	Violet, return, G.I. to playfield
J113, 34-pin Ribbon Cable, data, To/from CPU J211		J121-7	White-Brown, 6.8VAC, G.I. to playfield
		J121-8	White-Orange, 6.8VAC, G.I. to playfield
J114-1	Gray-Green, +12V, to J210-6,7; J904-2	J121-9	White-Yellow, 6.8VAC, G.I. to playfield
J114-2	Gray-Green, +12V, to 8-Driver Brd. J2-6	J121-10	White-Green, 6.8VAC, G.I. to playfield
J114-3	Gray, +5V, to 8-Driver Brd. J2-3	J121-11	White-Violet, 6.8VAC, G.I. to playfield
J114-4	Gray, +5V, to J210-4,5; J3-1,3; J904-1		
J114-5	Black-White, ground, to J210-1,3; J3-4,5; J904-4,5	J122-1	Blue-Brown, sol. 25 drive, to playfield flashlamp
J114-6	N/C	J122-2	Blue-Red, sol. 26 drive, to playfield flashlamp
J114-7	Black-White, ground, to 8-Driver Brd. J2-1	J122-3	Blue-Orange, sol. 27 drive, to playfield flashlamp
		J122-4	Blue-Yellow, sol. 28 drive, to playfield flashlamp
J115-1	Yellow-White, 6.8VAC, from xformer secondary	J122-5	N/C
J115-2	White-Brown, 6.8VAC, from xformer secondary	J122-6	N/C
J115-3	White-Brown, 6.8VAC, from xformer secondary	J122-7	N/C
J115-4	White-Orange, 6.8VAC, from xformer secondary	J122-8	N/C
J115-5	White-Yellow, 6.8VAC, from xformer secondary	J122-9	N/C
J115-6	White-Yellow, 6.8VAC, from xformer secondary		
J115-7	Orange, 6.8VAC, from xformer secondary	J123-1	N/C
J115-8	Orange, 6.8VAC, from xformer secondary	J123-2	N/C
J115-9	N/C	J123-3	N/C
J115-10	Green, 6.8VAC, from xformer secondary	J123-4	N/C
J115-11	Brown, 6.8VAC, from xformer secondary	J123-5	N/C
J115-12	Brown, 6.8VAC, from xformer secondary		
		J124-1	Blue-Brown, sol. 25 drive, to backbox flashlamp
J116-1	N/C	J124-2	Blue-Red, sol. 26 drive, to backbox flashlamp
J116-2	Gray-Yellow, +12V, to Coin Door J2-4	J124-3	Blue-Orange, sol. 27 drive, to backbox flashlamp
J116-3	Black, ground, to Coin Door J2-5	J124-4	N/C
J116-4	N/C	J124-5	Blue-Yellow, sol. 28 drive, to backbox flashlamp
J117-1	N/C	J125-1	Black-Brown, sol. 17 drive, to backbox flashlamp
J117-2	Gray-Yellow, +12V, to Dot Matrix Controller J606-7	J125-2	N/C
J117-3	Black, ground, to Dot Matrix Controller J606-3	J125-3	N/C
J117-4	Gray, +5V, to Dot Matrix Controller J606-5	J125-4	N/C
		J125-5	N/C
J118-1	N/C	J125-6	Blue-Green, sol. 21 drive, to backbox flashlamp
J118-2	Gray-Yellow, +12V, to playfield boards	J125-7	Blue-Black, sol. 22 drive, to backbox flashlamp
J118-3	Black, ground, to playfield boards	J125-8	Blue-Violet, sol. 23 drive, to backbox flashlamp
J118-4	N/C	J125-9	Blue-Gray, sol. 24 drive, to backbox flashlamp

Power Driver Board Continued...

J126-1	Black-Brown, sol 17 drive, playfield flashlamp	J133-1	N/C
J126-2	Black-Red, sol. 18 drive, to EMI board	J133-2	N/C
J126-3	Black-Orange, sol. 19 drive, to D.C Motor Control brd	J133-3	N/C
J126-4	Black-Yellow, sol. 20 drive, to D.C. Motor Control brd	J133-4	N/C
J126-5	Blue-Green, sol. 21 drive, to playfield flashlamps	J133-5	N/C
J126-6	Blue-Black, sol. 22 drive, to playfield flashlamps	J133-6	N/C
J126-7	Blue-Violet, sol. 23 drive, to playfield flashlamps	J133-7	Red-Blue, lamp row 6, not used
J126-8	Blue-Gray, sol. 24 drive, to playfield flashlamps	J133-8	Red-Violet, lamp row 7, to cabinet
J126-9	N/C	J133-9	Red-Gray, lamp row 8, to cabinet
J126-10	N/C		
J126-11	N/C		
J126-12	N/C	J134-1	Red-Brown, lamp row 1, to playfield lamps
J126-13	N/C	J134-2	Red-Black, lamp row 2, to playfield lamps
		J134-3	N/C
J127-1	Brown-Black, sol. 9 drive, to playfield coil	J134-4	Red-Orange, lamp row 3, to playfield lamps
J127-2	N/C	J134-5	Red-Yellow, lamp row 4, to playfield lamps
J127-3	Brown-Red, sol. 10 drive, to playfield coil	J134-6	Red-Green, lamp row 5, to playfield lamps
J127-4	Brown-Orange, sol. 11 drive, to playfield coil	J134-7	Red-Blue, lamp row 6, to playfield lamps
J127-5	Brown-Yellow, sol. 12 drive, to playfield coil	J134-8	Red-Violet, lamp row 7, to playfield lamps
J127-6	Brown-Green, sol. 13 drive, to playfield coil	J134-9	Red-Gray, lamp row 8, to playfield lamps
J127-7	Brown-Blue, sol. 14 drive, to playfield coil		
J127-8	Brown-Violet, sol. 15 drive, to playfield coil	J135-1	N/C
J127-9	N/C	J135-2	N/C
		J135-3	N/C
J128-1	N/C	J135-4	N/C
J128-2	N/C	J135-5	N/C
J128-3	N/C	J135-6	N/C
J128-4	N/C	J135-7	N/C
J128-5	N/C	J135-8	N/C
		J135-9	N/C
J129-1	N/C		
J129-2	N/C	J136-1	N/C
J129-3	N/C	J136-2	N/C
J129-4	N/C	J136-3	Yellow-Gray, lamp column 8, to cabinet
J129-5	N/C		
J130-1	Violet-Brown, sol. 1 drive, to playfield coil	J137-1	Yellow-Brown, lamp column 1, to playfield lamps
J130-2	Violet-Red, sol. 2 drive, to playfield coil	J137-2	Yellow-Red, lamp column 2, to playfield lamps
J130-3	N/C	J137-3	Yellow-Orange, lamp column 3, to playfield lamps
J130-4	Violet-Orange, sol. 3 drive, to playfield coil	J137-4	Yellow-Black, lamp column 4, to playfield lamps
J130-5	Violet-Yellow, sol.4 drive, to playfield coil	J137-5	Yellow-Green, lamp column 5, to playfield lamps
J130-6	Violet-Green, sol. 5 drive, to playfield coil	J137-6	Yellow-Blue, lamp column 6, to playfield lamps
J130-7	N/C	J137-7	Yellow-Violet, lamp column 7, to playfield lamps
J130-8	Violet-Black, sol.7 drive, to backbox coil	J137-8	N/C
J130-9	N/C	J137-9	Yellow-Gray, lamp column 8, to playfield lamps
J131-1	N/C	J138-1	N/C
J131-2	N/C	J138-2	N/C
J131-3	N/C	J138-3	N/C
J131-4	N/C	J138-4	N/C
J131-5	N/C	J138-5	N/C
		J138-6	N/C
J132-1	N/C	J138-7	N/C
J132-2	N/C	J138-8	N/C
J132-3	N/C	J138-9	N/C
J132-4	N/C		
J132-5	N/C		

LAMPS

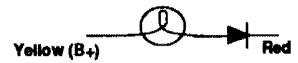

Column Row	1 Yellow-Brown J137-1 Q98	2 Yellow-Red J137-2 Q97	3 Yellow-Orange J137-3 Q96	4 Yellow-Black J137-4 Q95	5 Yellow-Green J137-5 Q94	6 Yellow-Blue J137-6 Q93	7 Yellow-Violet J137-7 Q92	8 Yellow-Gray J137-9 Q91
1 Red-Brown J134-1 Q90	Ball Save 11	Right Ramp Jackpot 21	Right Loop Jackpot 31	Right Ramp Explode 41	Underground Arrow 51	Claw "Capture Simon" 61	"Super Jackpot" 71	Center Ramp Middle 81
2 Red-Black J134-2 Q89	Fortress Multiball 12	Right Loop Explode 22	Standup 5 32	Right Ramp Car Chase 42	Underground Jackpot 52	Claw "Sup. Jets" 62	"Computer" 72	Center Ramp Outer 82
3 Red-Orange J134-4 Q88	Museum Multiball 13	Light Quick Freeze 23	Right Ramp Arrow 33	Quick Freeze 43	Standup 2 53	Claw "Prison Break" 63	"Demo Time" 73	Center Ramp Inner 83
4 Red-Yellow J134-5 Q87	Cryoprison Multiball 14	Freeze 4 24	Left Ramp Jackpot 34	Left Ramp Car Chase 44	Left Ramp Arrow 54	Claw "Freeze" 64	Not Used 74	Center Ramp Arrow 84
5 Red-Green J134-6 Q86	Wasteland Multiball 15	Claw Ready 25	Left Loop Jackpot 35	Extra Ball 45	Side Ramp Jackpot 55	Claw "ACMAG" 65	Not Used 75	Right Loop Arrow 85
6 Red-Blue J134-7 Q85	Shoot Again 16	Freeze 3 26	Car Crash Top 36	Start Multiball 46	Side Ramp Arrow 56	Middle Rollover 66	Standup 4 76	Buy-in Button 86
7 Red-Violet J134-8 Q84	Access Claw 17	Freeze 2 27	Standup 1 37	Car Crash Bottom 47	Left Loop Arrow 57	Top Rollover 67	Standup 3 77	Ball Launch 87
8 Red-Gray J134-9 Q83	Left Ramp Explode 18	Freeze 1 28	Car Crash Center 38	Left Loop Explode 48	Center Ramp Jackpot 58	Lower Rollover 68	Retina Scan 78	Start Button 88

SWITCHES

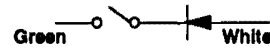

Dedicated Grounded Switches	Column Row	1 Green-Brown J207-1 U20-18	2 Green-Red J207-2 U20-17	3 Green-Orange J207-3 U20-16	4 Green-Yellow J207-4 U20-15	5 Green-Black J207-5 U20-14	6 Green-Blue J207-6 U20-13	7 Green-Violet J207-7 U20-12	8 Green-Gray J207-9 U20-11	Flipper Grounded Switches
Orange-Brown J205-1 Left Coin Chute D1	White-Brown J209-1 U18-11	Ball Launch 11	Slam Tilt 21	Trough 1 31	Left Slingshot 41	Left Ramp Enter 51	Side Ramp Enter 61	Chase Car 1 71	Claw "Capture Simon" 81	Black-Green J906-1 Lower Right E.O.S. F1
Orange-Red J205-2 Center Coin Chute D2	White-Red J209-2 U18-9	Left Handle Button 12	Coin Door Closed 22	Trough 2 32	Right Slingshot 42	Left Ramp Exit 52	Side Ramp Exit 62	Chase Car 2 72	Claw "Sup. Jets" 82	Blue-Violet J905-1 Lower Right Opto F2
Orange-Black J205-3 Right Coin Chute D3	White-Orange J209-3 U18-5	Start Button 13	Buy-in Button 23	Trough 3 33	Left Jet Bumper 43	Center Ramp 53	Left Rollover 63	Top Popper 73	Claw "Prison Break" 83	Black-Blue J906-3 Lower Left E.O.S. F3
Orange-Yellow J205-4 4th Coin Chute D4	White-Yellow J209-4 U18-7	Plumb Bob Tilt 14	Always Closed 24	Trough 4 34	Top Slingshot 44	Upper Rebound 54	Center Rollover 64	Elevator Hold 74	Claw "Freeze" 84	Blue-Gray J905-2 Lower Left Opto F4
Orange-Green J205-6 Normal Function Service Credits D5	White-Green J209-5 U19-11	Left Outlane 15	Claw Position 1 25	Trough 5 35	Right Jet Bumper 45	Left Loop 55	Right Rollover 65	Not Used 75	Claw "ACMAG" 85	Black-Violet J906-4 Upper Right E.O.S. F5
Orange-Blue J205-7 Normal Function Volume Down D6	White-Blue J209-7 U19-9	Left Inlane 16	Claw Position 2 26	Trough Jam 36	Right Ramp Enter 46	Standup 2 56	Eject 66	Bottom Popper 76	Upper Left Flipper Gate 86	Black-Yellow J905-3 Upper Right Opto F6
Orange-Violet J205-8 Normal Function Volume Up D7	White-Violet J209-8 U19-5	Right Inlane 17	Shooter Lane 27	Not Used 37	Right Ramp Exit 47	Standup 3 57	Elevator Index 67	Eyeball Standup 77	Car Chase Standup 87	Black-Gray J906-5 Upper Left E.O.S. F7
Orange-Gray J205-9 Normal Function Begin Test D8	White-Gray J209-9 U19-7	Right Outlane 18	Not Used 28	Standup 5 38	Right Freeway 48	Standup 4 58	Not Used 68	Standup 1 78	Lower Rebound 88	Black-Blue J905-5 Upper Left Opto F8

Opto Switch * = Not Used

WARNINGS & NOTICES

WARNING

FOR SAFETY AND RELIABILITY, substitute parts and equipment modifications are not recommended. Use of Non-WILLIAMS parts or modifications of game circuitry, may adversely affect game play, or may cause injuries.

SUBSTITUTE PART OR EQUIPMENT MODIFICATIONS may void FCC Type Acceptance.

BECAUSE THIS GAME IS PROTECTED by Federal copyright, trademark, and patent laws, unauthorized game conversions may be illegal under Federal law.

THIS 'CONVERSION' PRINCIPLE ALSO APPLIES to unauthorized facsimiles of WILLIAMS equipment, logos, designs, publications, assemblies, and games (or game feature not deemed to be public domain), whether manufactured with WILLIAMS components or not.

NOTICE

WILLIAMS, Lane-change and Multi-ball are trademarks of WILLIAMS ELECTRONICS GAMES, INC. Entire contents of this manual © 1994 WILLIAMS ELECTRONICS GAMES, INC.

WARNING

Note: This equipment has been tested and found to comply with the limits for a Class A digital device, pursuant to Part 15 of the FCC Rules. These limits are designed to provide reasonable protection against harmful interference when the equipment is operated in a commercial environment. This equipment generated, uses, and can radiate radio frequency energy and if not installed and used in accordance with the instruction manual, may cause harmful interference to radio communications. Operation of this equipment in a residential area is likely to cause harmful interference in which case the user will be required to correct the interference at his own expense.

RF Interference Notice

CABLE HARNESS PLACEMENTS and ground strap routing on this game have been designed to keep RF radiation and conduction within levels accepted by the FCC Rules.

TO MAINTAIN THESE LEVELS, reposition harnesses and reconnect ground straps to their original placements, if they become disconnected during maintenance.

FCC STICKER. Check the back of your game to verify that an FCC-certification sticker was attached to your game at the factory. All games that leave the WILLIAMS plant have been tested and found to comply with FCC Rules. Because the sticker is proof of this fact, legal repercussions to the owner and distributor may result, if the sticker is missing. If you receive a game, manufactured after December 1982, that has no FCC sticker, call WILLIAMS for advice or write us a note on your Game Registration Card. Be sure that the card bears your game's serial number.

Motion Picture Elements:
DEMOLITION MAN, characters, names and all related
indicia are trademarks of Warner Bros. © 1993.

Theme Music:
Demolition Man Score Music:
© 1993 WB Music Corp.
Composer: Elliot Goldenthal

Pinball Game:
© 1994 Williams Electronics Games, Inc.
ALL RIGHTS RESERVED



CAUTION

**Transport this game ONLY
with hinged backbox DOWN!**

FOR SERVICE... CALL your authorized WILLIAMS Distributor.