

The FLINTSTONES®

MANUAL AMENDMENT

The following drawing is from page 2-24 of the FLINTSTONES® Operators Manual. The part called out as item #9 in the picture in the manual should of been called out as item #6.

Please keep this amendment with your FLINTSTONES® Operators Manual.

A-17932 Diverter Assembly

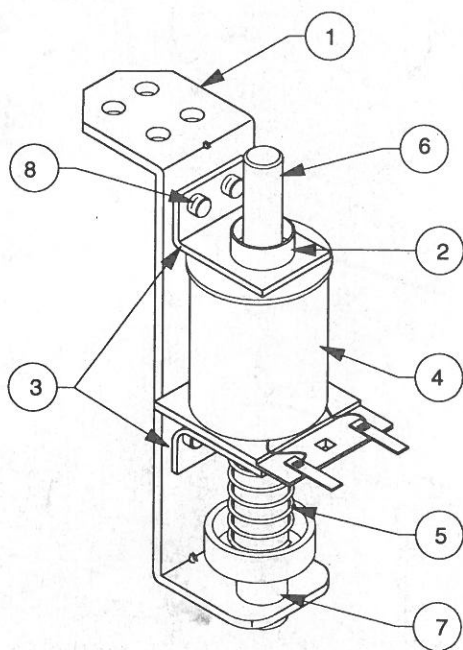

Item	Part No.	Description
1.	01-12441	Diverter Post Bracket
2.	03-7067-5	Coil Tubing
3.	01-8-508-T	Coil Retainer Bracket
4.	AE-27-1200	Coil Sub-Assembly
5.	10-135	Spring
6.	A-17986	Bell Armature Assembly
7.	23-6420	Rubber Grommet
8.	4008-01017-04	Mach. Screw, #8-32 x 1/4"