

*Bally*

16-50070.1-101  
February 1999



# REVENGE FROM MARS™

## OPERATIONS MANUAL



### MANUAL INCLUDES

Operations & Adjustments • Testing & Problem Diagnosis • Parts Information  
Wiring Diagrams & Schematics  
Williams Electronics Games, Inc., 3401 N. California Avenue, Chicago, IL 60618

## SOLENOID TABLE

Sol No.	Solenoid Function	Fuse	Power to Playfield	Power Wire Color	Drive Transistor	Drive to Playfield	Drive Wire Color	Solenoid Part Number or Flasher Type
01	LEFT MARTIAN	F101	J102-1	RED-BRN	Q59	J110-13	VIO-BRN	AE1-26-1500
02	RIGHT MARTIAN	F101	J102-1	RED-BRN	Q60	J110-14	VIO-RED	AE1-26-1500
03	JET EXIT POST	F101	J102-1	RED-BRN	Q61	J110-15	VIO-ORG	AE1-26-1500
04	RIGHT GATE	F101	J102-1	RED-BRN	Q62	J110-16	VIO-YEL	A-14406
05	LEFT GATE	F102	J102-2	RED-BLK	Q63	J110-17	VIO-GRN	A-14406
06	DROP TARGET DOWN	F102	J102-2	RED-BLK	Q64	J110-18	VIO-BLU	SM1-26-600
07	DROP TARGET UP	F102	J102-2	RED-BLK	Q65	J110-19	VIO-BLK	AE1-26-1200
08	RIGHT POPPER	F102	J102-2	RED-BLK	Q66	J110-20	VIO-GRY	AE1-25-1000
09	TROUGH EJECT	F103	J102-3	RED-ORG	Q51	J112-11	BRN-BLK	AE1-26-1500
10	LEFT SLINGSHOT	F103	J102-3	RED-ORG	Q52	J112-12	BRN-RED	AE1-26-1200
11	RIGHT SLINGSHOT	F103	J102-3	RED-ORG	Q53	J112-13	BRN-ORG	AE1-26-1200
12	LEFT JET BUMPER	F103	J102-3	RED-ORG	Q54	J112-14	BRN-YEL	AE1-26-1200
13	RIGHT JET BUMPER	F100	J102-7	RED-YEL	Q55	J112-15	BRN-GRN	AE1-26-1200
14	BOTTOM JET BUMPER	F100	J102-7	RED-YEL	Q56	J112-16	BRN-BLU	AE1-26-1200
15	AUTO PLUNGER	F100	J102-7	RED-YEL	Q57	J112-17	BRN-VIO	AE1-23-800
16	RIGHT LOCKUP	F100	J102-7	RED-YEL	Q58	J112-18	BRN-GRY	AE1-23-800
17	CENTER ARROW FLASHER	F109	J102-8	RED-WHT	Q43	J110-1	BLU-BRN	#906
18	NOT USED	F109			Q44	J110-2	BLU-RED	
19	NOT USED	F109			Q45	J110-3	BLU-ORG	
20	NOT USED	F109			Q46	J110-4	BLU-YEL	
21	NOT USED	F109			Q47	J110-5	BLU-GRN	
22	RIGHT POPPER FLASHER	F109	J102-8	RED-WHT	Q48	J110-6	BLU-BLK	#906
23	LEFT ARCH FLASHER	F109	J102-8	RED-WHT	Q49	J110-7	BLU-VIO	#89
24	NOT USED	F109			Q50	J110-8	BLU-GRY	
25	RIGHT ARCH FLASHER	F109	J102-8	RED-WHT	Q67	J112-9	BLK-BRN	#89
26	LEFT MARTIAN FLASHER	F109	J102-8	RED-WHT	Q68	J112-10	BLK-RED	#89
27	RIGHT MARTIAN FLASHER	F109	J102-8	RED-WHT	Q69	J112-19	BLK-ORG	#89
28	RED HOT DOG FLASHER	F109	J102-8	RED-WHT	Q70	J112-20	BLK-YEL	#906
	<b>Flipper Circuits</b>							
33	LOW RIGHT FLIPPER PWR				Q35	J112-1	YEL-GRN	
34	LOW RIGHT FLIPPER HOLD	F104	J103-1	RED-GRN	Q36	J112-2	ORG-GRN	FL1-11629
35	LOW LEFT FLIPPER PWR				Q37	J112-3	YEL-BLU	
36	LOW LEFT FLIPPER HOLD	F105	J103-2	RED-BLU	Q38	J112-4	ORG-BLU	FL1-11629
37	LOCK DIVERTER POWER				Q39	J112-5	YEL-VIO	
38	LOCK DIVERTER HOLD	F106	J103-3	RED-VIO	Q40	J112-6	ORG-VIO	FL1-22241
39	UP/DOWN RAMP POWER				Q41	J112-7	YEL-GRY	
40	UP/DOWN RAMP HOLD	F107	J103-4	RED-GRY	Q42	J112-8	ORG-GRY	FL1-11753

# DECLARATION OF CONFORMITY

## WILLIAMS ELECTRONICS GAMES, INC.

3401 N. CALIFORNIA AVE.  
CHICAGO, IL 60618  
U.S.A.

WE, HEREBY DECLARE UNDER SOLE RESPONSIBILITY THAT  
THE MODEL: "REVENGE FROM MARS" 50270,50370,50470,50770,50970,51070,  
51170,51270, 51370,51470,51870,52070,52170,52370,57270

**TO WHICH THIS DECLARATION RELATES IS IN CONFORMITY  
WITH THE FOLLOWING EUROPEAN PRODUCT SAFETY**

**ELECTROMAGNETIC COMPATABILITY DIRECTIVE**  
(89/336/EEC AND AMENDMENTS 91/C162/08, 92/31/EEC,93/68/EEC

**ELECTRICAL EQUIPMENT DESIGNED FOR USE WITHIN  
CERTAIN VOLTAGE LIMITS DIRECTIVE**  
(73/23/EEC AND AMENDMENTS 88/C168/02, 92/C210/01,  
93/68/EEC, 94/C199/03, 95/C214/02)

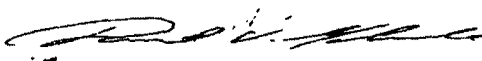
AS IS VERIFIED BY COMPLIANCE WITH THE FOLLOWING STANDARDS

EN 55014:1993 EN55104:1995 EN61000-4-2: 1995  
IEC 801-3: 1984 (EN61000-4-3 ) EN61000-4-4: 1995 EN61000-4-5: 1995  
ENV50141: 1993 (EN61000-4-6 ) EN61000-4-11: 1994 EN60335-1: 1995  
IEC 335-2-82 (DRAFT)

FREBRUARY 22, 1999

Date issued:

MANUFACTURE'S SIGNATURE



**DAN GALARDE**

CORPORATE V.P. OF QUALITY



## **THESE ARE SOME OF THE NEW FEATURES AVAILABLE WITH PINBALL 2000:**

### **GAME PLAY**

The video display allows dynamic interactive features.

The video display allows many playfield devices to occupy the same position at different times in the game.

Video can clearly lead the player through the game, making clear what is happening each time that a target is hit. You see the result at the point of impact with the ball.

The video 'mechanisms' allow for simpler 'real' mechanisms on the playfield. The result is reduced service problems.

### **ELECTRONICS**

The backbox contains a commercial motherboard, housed in a PC style case, and a monitor. The system will become more powerful as new motherboards are introduced.

The Power Driver board is located in the cabinet and is connected to the PC via a standard parallel printer cable. A laptop or a service computer can use this connection for powerful troubleshooting.

The PINBALL 2000 Power Driver board is secured with two screws and has 17 uniquely keyed connectors allowing for easy replacement. The WPC-95 Power Driver board, on the other hand, was secured with nine screws and had 39 connectors.

Each fuse has its own LED indicator.

Blown fuses and burnt out bulbs are shown by built in diagnostics on the video screen.

A PC connector at the coin door allows for advanced diagnostics, (a laptop computer can become a portable test fixture), data transfer and software updates.

The operator may add a low cost modem to the PC for remote data retrieval, an Internet connection and software updates. A revenue sharing system could be implemented on this platform.

### **SOFTWARE UPDATES**

There are no EPROMs in the system. Software updates are done using a PC connected to the front door or via a modem and phone line.

There will be a chip based updated method available for a low-tech customer that is similar to updating a video game hard drive program.

All software resides in the backbox section. The system has been designed such that the software can be updated without uncrating the backbox.

### **CABINET AND BACKBOX FEATURES**

The attendant can gain access to playfield through a key-released front molding. Playfield glass may be removed by location attendant for minor problems) such as trapped balls. Playfield remains locked by passive latch built into coin door.

Computer Case is an easy pull-out drawer in the backbox. This allows for easy access for troubleshooting and service. Entire CPU section may be swapped out in 60 seconds.

Backbox locks provides higher security than previous design and secures CPU case for transit.

### **CABINET AND BACKBOX FEATURES CONTINUED...**

Provision available for CPU case padlock in backbox.

Backglass stores easily over playfield glass and provides reflected image while servicing.

The playfield is at proper playing angle with all leg levelers in their lowest position.

The wiring from the backbox to the cabinet is only a few cables.

Main cable from the cabinet mounted driver board is significantly reduced in length for greater reliability and lower emissions and interference.

The cover for the Power Driver board is hinged to ensure that it is put back in its protective position after service is performed.

DCS II sound system delivers stereo sound directly to the player to enhance game excitement without requiring a high volume level.

### **CONVERTIBILITY**

**Operators are able to use the convertibility to rotate their pinball games by moving playfield and a PC board instead of the entire machine. This is possible because of the ease of conversion and the way the devices on the bottom of the playfield are protected by the underside runners.**

The playfield has unique runners protecting the parts on the underside of the playfield. These runners provide the following features:

Installation and removal of the playfield is an easy process requiring little physical strength. This ease is enhanced due to the main cable's attachment to the cabinet instead of the playfield.

The devices on the bottom of the playfield are naturally protected in the shipment of these kits.

The playfield may be handled and stored outside of the cabinet without fear of damage to the devices attached to the underside.

# REVENGE FROM MARS™



**Williams Electronics Games, Inc. reserves the rights to make modifications and improvements to its products. The specifications and parts identified in this manual are subject to change without notice.**

# **TABLE OF CONTENTS**

<b>SECTION 1 - GAME OPERATION &amp; TEST INFORMATION</b> .....	1-1
Pinball Game Assembly Instructions.....	1-2
Raising the Playfield.....	1-8
Game Control Locations.....	1-9
Game Operation.....	1-10
Menu System Operation and System Menu.....	1-11
<b>Diagnostics</b> .....	1-12
Switch Edges Test.....	1-12
Single Switch Test.....	1-12
DIP Switch Test.....	1-12
Solenoid Test.....	1-13
Single Lamp Test.....	1-13
Lamp Row/Column Test.....	1-13
All Lamps Test.....	1-13
Video Test.....	1-13
Fuse Check.....	1-13
<b>Adjustments</b> .....	1-14
Audio Adjustments.....	1-14
System Adjustments.....	1-15
Feature Adjustments.....	1-16
Game Pricing.....	1-17
High Scores.....	1-18
<b>Bookkeeping</b> .....	1-19
Main Audits.....	1-19
Earning Audits.....	1-19
Standard Audits.....	1-20
Feature Audits.....	1-20
Histograms.....	1-20
Time Stamps.....	1-20
Earnings Charts.....	1-20
<b>Utilities</b> .....	1-21
System Information.....	1-21
Show Shell Location.....	1-21
Set Location I.D.....	1-22
Update Game Code.....	1-22
Clear Audits.....	1-22
Clear Coins.....	1-22
Reset High Scores.....	1-22
Set Clock.....	1-22
Factory Adjustments.....	1-22
Factory Reset.....	1-22
Install Presets.....	1-22
Clear Credits.....	1-22



**Section 1 Continued...**

<b>Printouts</b> .....	1-23
<b>Language</b> .....	1-24
Routine Maintenance Information.....	1-25
Service Information.....	1-25
LED and Fuse List.....	1-29

**Section 2 - Game Parts Information.....2-1**

Cabinet Assembly.....	2-2
Back Box Assembly.....	2-4
Prism PCB Board.....	2-5
Power Driver Board Assembly.....	2-6
Audio Amplifier Board Assembly.....	2-8
Coin Door Interface PCB Assembly.....	2-9
2 Switch Flipper PCB Assembly.....	2-9
Trough IR LED Board Assembly.....	2-10
Trough IR Photo Transistor Board Assembly.....	2-10
10-Opto Board Assembly.....	2-11
Auto-Fire Board Assembly.....	2-12
Ball Trough Assembly Complete.....	2-13
Right Flipper Assembly.....	2-14
Left Flipper Assembly.....	2-15
Kicker Assembly.....	2-16
Skip Ramp Assembly.....	2-17
Popper Assembly.....	2-18
1-Bank Drop Target Assembly.....	2-19
3-Ball Popper Assembly.....	2-20
Diverter Mechanism Assembly.....	2-21
Opto Bracket Assembly.....	2-22
Ball Gate Actuator Assembly.....	2-22
Up/Down Post Assembly.....	2-23
Ball Catcher Assembly.....	2-24
Martian Mechanism Assembly.....	2-25
Jet Coil & Bracket Assembly.....	2-26
Jet Bumper Assembly.....	2-27
Jet Bumper Assembly.....	2-28
Tilt Mechanism Assembly.....	2-29
Power Control Box Assembly.....	2-30
Power Interface/Cordset Application Chart.....	2-31
Computer Case Assembly.....	2-32
Upper Playfield Ramps.....	2-33
Upper Playfield Parts.....	2-34
Lower Playfield Parts.....	2-36
Rubber Parts.....	2-37
Lamp Matrix A.....	2-38

**Section 2 Continued...**

Lamp Matrix B .....	2-40
Playfield Switches.....	2-42
Solenoids/Flashlamps.....	2-44
Lamp Matrix A and B.....	2-46
Switch Matrix.....	2-47
Solenoid Table.....	2-48

**Section 3 - Wiring Diagrams & Schematics.....** 3-1

Lamp Matrix A.....	3-2
Lamp Matrix B and Lamp Matrix Circuit.....	3-3
Switch Matrix, Coin Slot Switches, Diagnostic Switches, Playfield Flipper E.O.S. Switches, and Cabinet Flipper Switches.....	3-4
Switch Matrix Circuit, Coin Slot Switch Circuit, and Diagnostic Switch Circuit.....	3-5
Playfield Flipper E.O.S. Switch Circuit, and Cabinet Flipper Switch Circuit.....	3-6
Solenoid Table.....	3-7
Solenoid Wiring-Coils.....	3-8
Solenoid Wiring-Flashlamps.....	3-9
Circuit for Solenoids 1 to 16, Circuit for Solenoids 17 to 28.....	3-10
Flipper Coil Circuit.....	3-11
Upper and Lower Right Flipper Circuits.....	3-12
Upper and Lower Left Flipper Circuits.....	3-13
2 Switch Flipper Button Assembly.....	3-14
10-Opto Switch Board Assembly.....	3-15
10-Opto Switch Board Schematic.....	3-16
Ball Trough Infrared LED Board Assembly.....	3-17
Ball Trough Infrared Photo Transistor Board Assembly.....	3-18
Wiring Diagram for the Ball Trough Assembly Opto Switches.....	3-19
Individual LED and Photo Transistor Board Assemblies .....	3-20
Wiring Diagram for Individual Playfield Opto Switches.....	3-21
Coin Door Interface Board.....	3-22
Coin Door Interface Board Schematic.....	3-24
Power Driver Board Interboard Wiring.....	3-25

# SECTION ONE

## GAME OPERATION AND TEST INFORMATION

### ROM SUMMARY

IC	TYPE	BOARD	LOCATION	PART NUMBER
Image	ROM	Prism ROM Daughter Card	U100	5341-16205-00
Image	ROM	Prism ROM Daughter Card	U101	5341-16206-00
Image	ROM	Prism ROM Daughter Card	U102	5341-16207-00
Image	ROM	Prism ROM Daughter Card	U103	5341-16208-00
Image	ROM	Prism ROM Daughter Card	U104	5341-16209-00
Image	ROM	Prism ROM Daughter Card	U105	5341-16210-00
Image	ROM	Prism ROM Daughter Card	U106	5341-16211-00
Image	ROM	Prism ROM Daughter Card	U107	5341-16212-00
Sound	ROM	Prism ROM Daughter Card	U109	5341-16213-00
Sound	ROM	Prism ROM Daughter Card	U110	5341-16214-00

# PINBALL GAME ASSEMBLY INSTRUCTIONS

It takes two people to assemble a PINBALL 2000 game.

Do not plug in or switch on power to the cabinet until assembly is complete!

It is not necessary to open the computer case to assemble a PINBALL 2000 game. However, should you ever find it necessary to open the case, be sure to replace the computer case cover. Failure to do so will void FCC, UL and CE compliance, and may cause damage to the PC boards in the case. The foam lining of the cover holds the PC boards securely in place and protects them from vibrations that normally occur in a pinball game.

**Power:** Domestic 120V @ 60Hz  
Foreign 230V @ 50Hz  
Japan 100V @ 50Hz  
**Temp:** 32°F to 100° F, (0°C to 38°C)  
**Humidity:** Not to exceed 95% relative.

**Dimensions:** Width: 24" approx.  
Length: 48" approx.  
Height: 73" approx.  
**Weight:** Backbox: 130 LB approx.  
Cabinet: 230 LB approx.

1. Remove all cartons, parts, and other items from the shipping containers and set them aside.
2. The leg levelers, nut, and leg bolts are among the parts in the cash box. Install a leg leveler and nut on each of the front and rear legs. Place the cabinet on a support. Using two leg bolts in each leg attach the rear legs to the cabinet. Next, using two leg bolts in each leg, attach the front legs to the cabinet. See Figure 1.
3. Once the legs are securely attached, remove the support from the cabinet. Adjust the leg levelers so that the cabinet does not wobble.

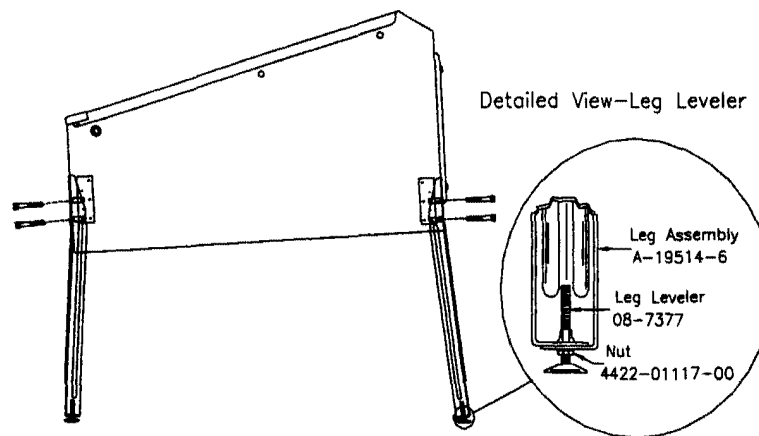


Figure 1

4. Remove the playfield from the cabinet before trying to attach the backbox. To do this, unlock and open the coin door. Pull the yellow lever, (located to the left of the coin door), to the right. The front molding pops up. Lift the molding from the cabinet. Slide the playfield glass down and lift it off of the cabinet. See Figure 2.

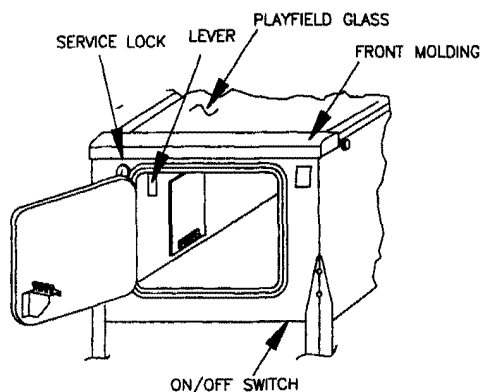
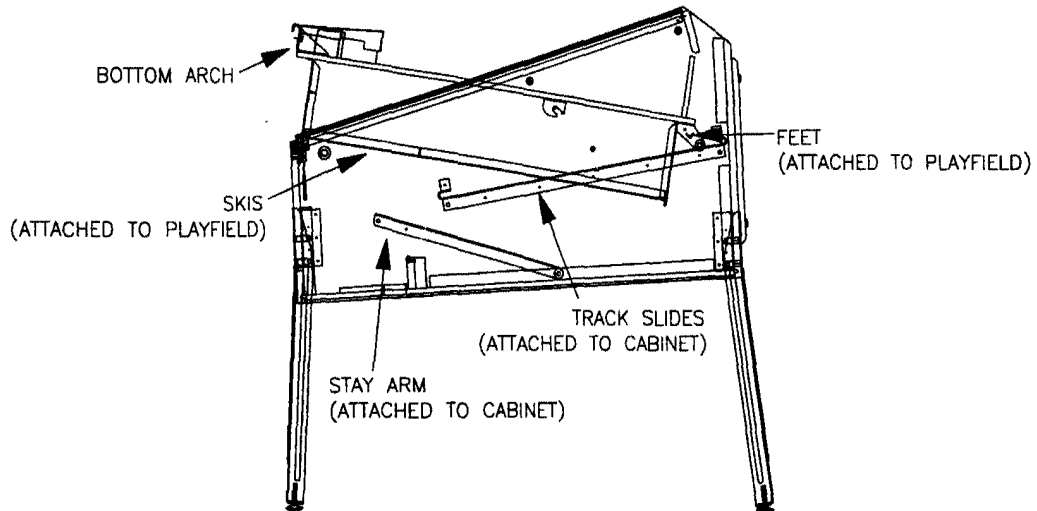


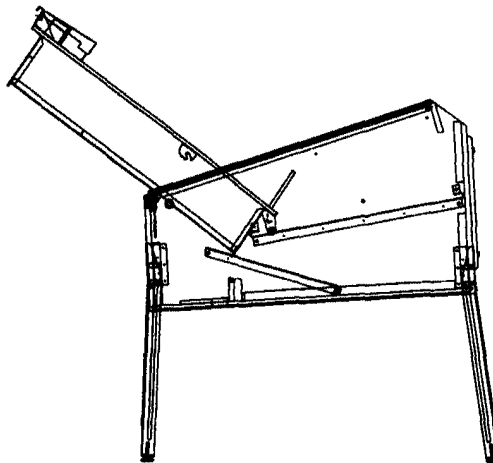
Figure 2

5. Lift the playfield by the support bracket under the bottom arch. Rest the playfield on the top of the cabinet as shown in Figure 3. Close the coin door.

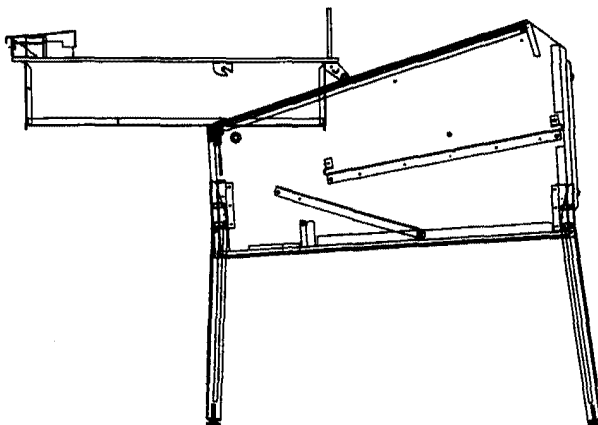


**Figure 3**

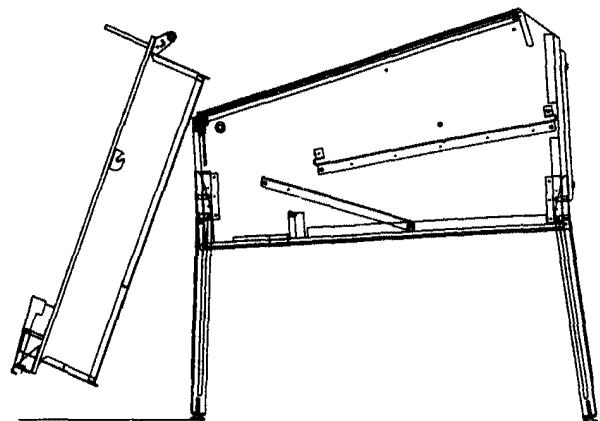
6. Firmly grasp the playfield on the sides and slide it forward (toward you) along the bottom track slide brackets. Do not unplug the cables on the bracket attached to the back of the playfield. Rotate the front of the playfield down and set it on the floor as shown in Figures 4, 5, and 6.



**Figure 4**

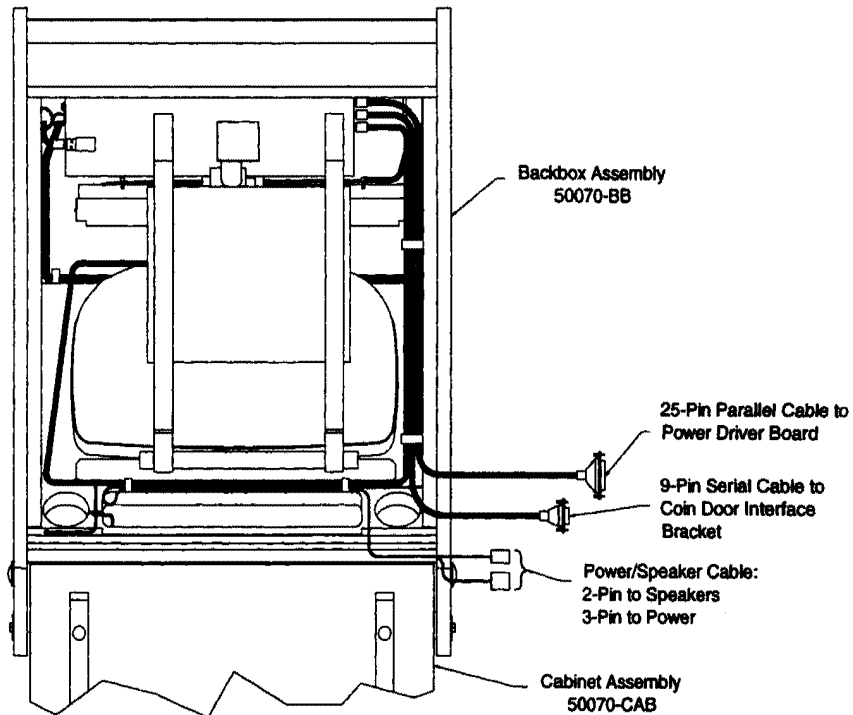


**Figure 5**



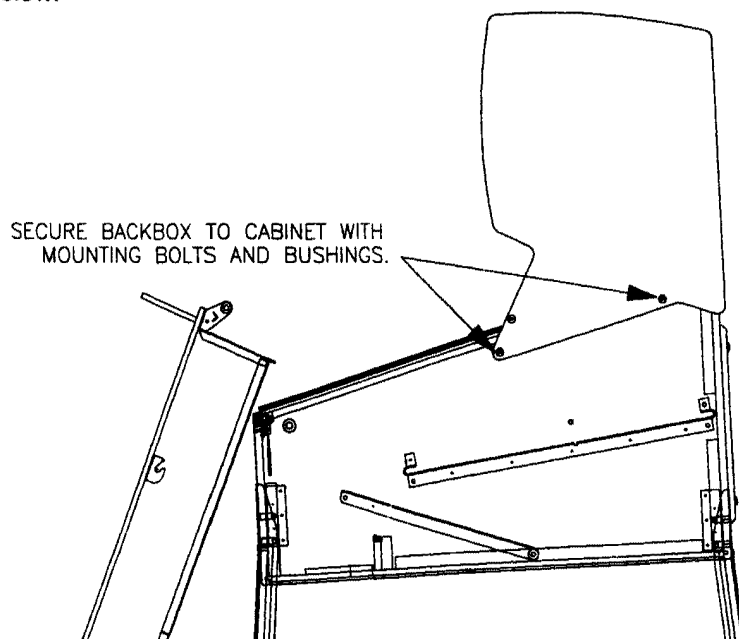
**Figure 6**

7. Next prepare the backbox. Locate the four mounting bolts and bushings among the parts in the cash box and set them aside. Cut the tie-wrap that holds the 9-pin serial cable, the 25-pin parallel cable and the power/speaker cable to the wood shipping brace. The shipping brace is held in place by two screws located on the left and right sides of the backbox. Remove the screws and shipping brace from the backbox.
8. Stand the backbox upright. Unlock and remove the rear door. Pull the three cables out through the back door opening and let them hang down the rear of the backbox. See Figure 7.



**Figure 7**

9. **With the help of another person, carefully lift the backbox and set it on the cabinet.**
10. Line up the four mounting holes in the cabinet with the mounting holes in the backbox. Place a bushing in each of the mounting holes in the cabinet. Fasten the two assemblies together by inserting a bolt through the backbox and into the cabinet in each of the four mounting holes. See Figure 8 below.



**Figure 8**

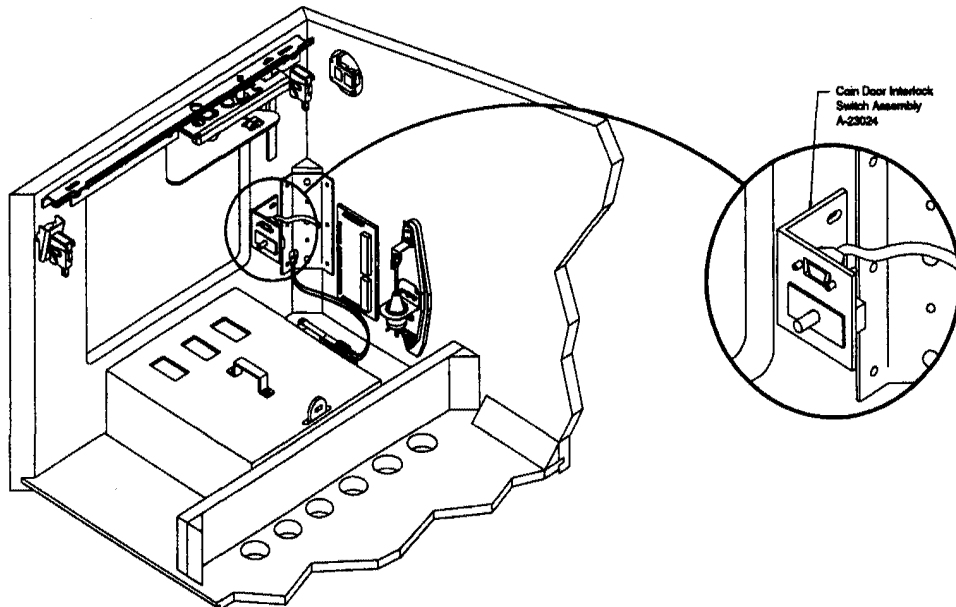


## CAUTION

**FAILURE TO INSTALL the backbox mounting hardware properly can cause personal injury.**

- Slide the three cables back inside the backbox and let them hang down inside the cabinet.
- Next, connect the cables. *Do not force cables onto connectors. Cables should plug in easily.* The three cables coming from the backbox and going to the cabinet are the 9-pin serial cable, the 25-pin parallel cable and the power/speaker cable. There is one cable from the cabinet that goes to the backbox, it is the ground strap. See Figure 8, on the previous page.

Plug the 9-pin serial cable into the bracket near the coin door and screw it securely in place (see Figure 9 below). Plug the 25-pin parallel cable into the Power Driver board at J100 and screw it securely in place. The power/speaker cable has two connectors, a 2-pin connector for the speakers and a 3-pin connector for power. Plug the speaker cable connector into the 2-pin connector near the speakers, and plug the power cable connector into the 3-pin isolation tap from the transformer, which is also located near the speakers. Be sure to match the wire colors on the speaker and power cables.



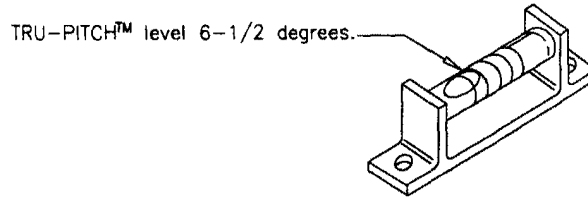
**Figure 9**

The last cable to attach is the ground strap. Remove the four screws holding the backbox rear door. Unlock and remove the rear door. The ground strap is located in the rear of the cabinet. Reach through the rectangle hole and pull the ground strap up. Remove the wing nut from the ring lug located to the left of the rectangle hole. Slip the ground strap loop over the ring lug and secure it in place with the wing nut. Replace and lock the backbox rear door. Replacing the screws is optional.

- Open the coin door. Carefully, lift the playfield from the front and tip the back of it onto the slides. Slide it back into the cabinet. Be sure that the cables at the back of the playfield are not kinked.
- Place a level or an inclinometer on the playfield surface. Adjust the leg levelers for proper playfield level (side-to-side).

**NOTE:** This measurement must be made *ON the playfield, not the cabinet or the playfield cover glass.* Tighten the nut on each leg leveler shaft to maintain this setting.

15. The TRU-PITCH™ level is located on the right shooter rail. This allows the playfield pitch angle to be properly adjusted **WITHOUT REMOVING THE GLASS**. The first line (closest to the front of the game) on the level is approximately 6 degrees. Every line thereafter is approximately another 1/2 degree of pitch. The recommended pitch is 6-1/2 degrees. The **NOSE** of the bubble should be between the first and second line on the level (see diagram below).

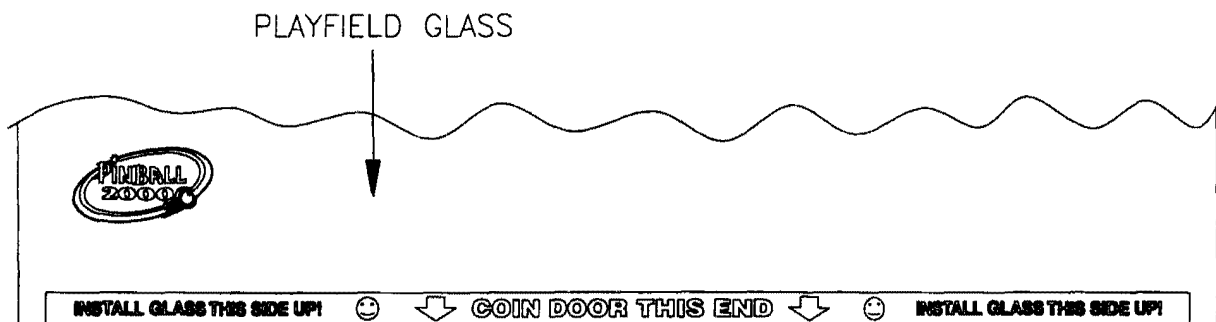


**Figure 10**

**IMPORTANT!**

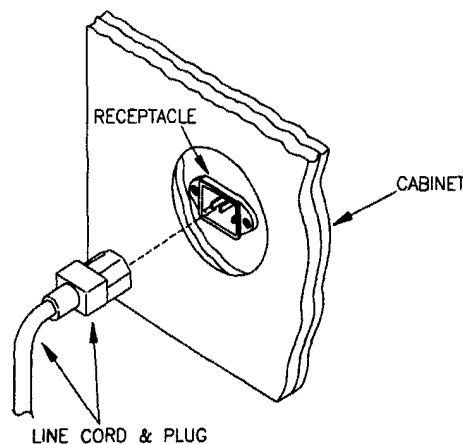
*Playfield pitch angle can affect the operation of the plumb bob tilt. The plumb bob weight is among the parts in the cash box. After completion of the desired playfield pitch angle setting, the operator should install the weight and adjust this tilt mechanism for proper operation. The unit is factory installed for a 6-1/2 degree angle. If an adjustment is necessary, loosen the screw at the bottom of the unit. Move the pointer, one groove at a time to the left or the right, depending on the degree desired. Hold the pointer in place and tighten screw.*

16. Be sure the **required number** of balls is installed.
17. Replace the playfield glass. Be sure that the **PINBALL 2000** logo is in the lower left corner and that the 'smiley' faces are visible. See Figure 11 below. Snap the front molding securely into place. Close and lock the coin door.



**Figure 11**

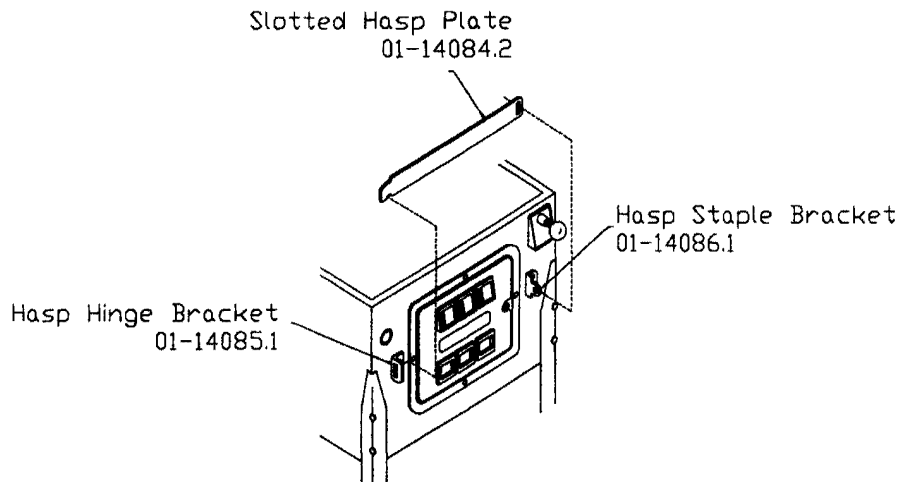
18. Plug the line cord into the game cabinet. Match the prongs on the plug with the holes in the receptacle, and push the line cord securely into place. See Figure 12.



**Figure 12**



19. Move the game into the desired location. Adjust the leg levelers so that the playfield pitch is the recommended 6-1/2 degrees. This places the game in a FIXED position.
20. If a padlock is desired, install the security bar as shown below in Figure 13.



**Figure 13**

21. Plug the game into a properly grounded outlet.



**CAUTION**

**After assembly and installation at its site location, this game must be plugged into a properly grounded outlet to prevent shock hazard, and to assure proper game operation. DO NOT use a 'cheater' plug to defeat the ground pin. DO NOT cut off the ground pin.**

22. **POWERING UP.** With the coin door closed, plug the game in and switch it on. In normal operation the game performs Start-up Tests. Once the Start-up tests have been successfully completed, the game enters the Attract mode.
23. **IMPORTANT:** Fill out and return the registration card.

## RAISING THE PLAYFIELD

### CAUTION

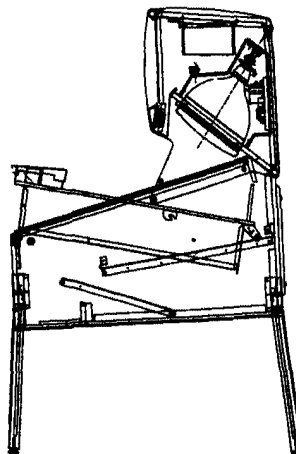
This game uses ski assemblies to raise and lower the playfield. Be sure the back of the playfield skis slide along the cabinet tracks until the feet hook into the loop at the end of the track.

#### Before Raising the Playfield:

Be sure there are no balls present in any of the ball-holding playfield devices (i.e. poppers). Raising the playfield with balls present in these locations may cause them to come loose and damage the playfield. Use the "Empty Balls Test" to remove all of the balls from these locations.

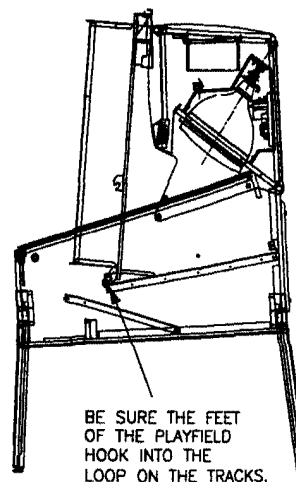
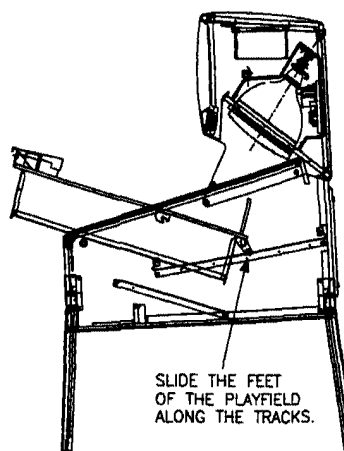
#### To Raise the Playfield:

1. Open the coin door. Remove the front molding and the playfield glass. Lift the playfield by the metal bracket under the bottom arch. Rest it on the top of the cabinet.
2. Close the coin door. Grasp the playfield on the sides and pull it toward you along the track slides. Rotate the front of the playfield up and back toward the backbox.



#### To Lower the Playfield

1. Rotate the front of the playfield down and push it back, away from you, along the track slides. Rest it on top of the cabinet. Open the coin door.
2. Grasp the playfield by the metal bracket under the bottom arch and lower it back into the cabinet. Replace the playfield glass and the front molding. Close and lock the coin door.



# GAME CONTROL LOCATIONS

## Cabinet Switches

The ON/OFF SWITCH is on the bottom of the cabinet near the right front leg.

The START BUTTON is a push-button to the left of the coin door on the cabinet exterior. Press the Start button to begin a game, or during the diagnostic mode, to ask for HELP.

## Coin Door Buttons

The operator controls all game adjustments, obtains bookkeeping information, and diagnoses problems, using only four push-button switches mounted on the inside of the coin door. The coin door buttons have two modes of operation Normal Function and Test Function.

### NORMAL FUNCTION

The SERVICE CREDITS button puts credits on the games that are not included in any of the game audits.

The VOLUME UP (+) button raises the sound level of the game. Press and hold the button until the desired level is reached.

The VOLUME DOWN (-) button lowers the sound level of the game. Press and hold the button until the desired level is reached. See the Adjustment menu to turn the sound down all the way.

The \*\*BEGIN TEST button starts the Menu System operation and changes the coin door buttons from Normal Function to Test Function.

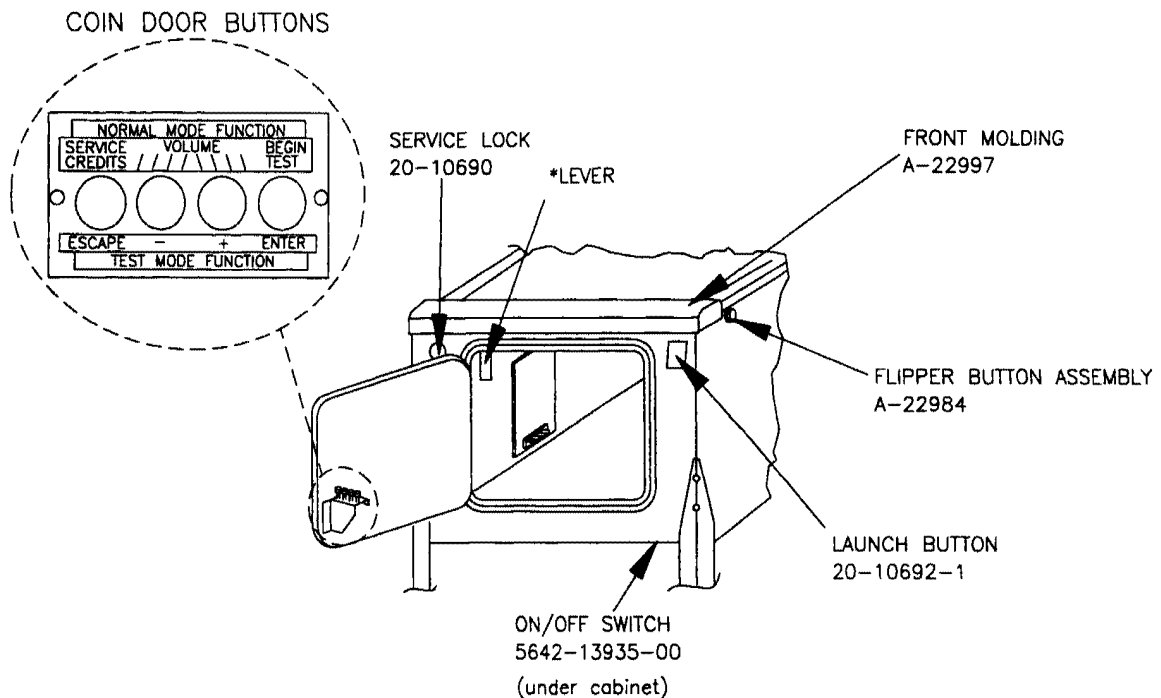
### TEST FUNCTION

The ESCAPE button allows you to get out of a menu selection or return to the Attract mode.

The UP (+) button allows you to cycle forward through the menu selections or adjustment choices.

The DOWN (-) button allows you to cycle backward through the menu selections or adjustment choices.

The ENTER button allows you to get into a menu selection or lock in an adjustment choice.



The START BUTTON (p/n 20-9663-16) is not shown on this drawing. It is located below the service lock.

\*The LEVER is part of the LOCK BRACKET ASSEMBLY (p/n A-22996).

\*\* To reset the High Scores, press and hold the BEGIN TEST button.

## GAME OPERATION

### CAUTION

After assembly and installation at its location, this game must be plugged into a properly grounded outlet to prevent shock hazard, and to assure proper game operation. DO NOT use a 'cheater' plug to defeat the ground pin on the line cord. DO NOT cut off the ground pin.

**POWERING UP.** With the coin door closed, plug the game in, and switch it on. The game performs Start-up Tests. A test pattern and 'PLEASE WAIT' appears on the screen. The screen changes and 'TESTING' appears on the screen. Once the Start-up tests have been successfully completed the game goes into the Attract mode.

*Note: After the game has been on location for a time, the Start-up tests may contain messages concerning game problems.*

**ATTRACT MODE.** During the Attract mode, the screen shows a series of messages informing the player of the recent highest scores.

**CREDIT POSTING.** Insert coin(s). The screen shows the number of credits purchased.

**STARTING A GAME.** Press the Start button. A ball is ejected into the shooter lane. Press the Ball Launch button on the cabinet to send the ball onto the playfield and begin game play. If credits are posted, additional players may enter the game by pressing the Start button once for each player, before the end of play on the first ball.

**TILTS.** Actuating the cabinet slam tilt switch inside the cabinet ends the current game and proceeds to the Game-over mode. With the third closure of the plumb bob tilt switch, the player loses the remaining play of that ball, but can complete the game.

**END OF A GAME.** All earned scores and bonuses are awarded. If a player's final score exceeds the specified value, the player receives a designated award for achieving the current highest score. A random digit set appears in the display. An award may be given when the last two digits of any player's score match the random digits.

**GAME-OVER MODE.** The Game-over screen shows the high scores and the game proceeds to the Attract Mode.

## MENU SYSTEM OPERATION

The System Menu allows you to choose from several menus, which in turn, lead to other menus to choose from. To access the System Menu, open the coin door and press the Enter button. The System Menu appears on the screen. Press either the Up or the Down buttons to move the cursor up or down the screen. Notice how the menu options are highlighted in order. A menu option must be highlighted for it to be selected. To open a System Menu item, (Diagnostics menu, Adjustments menu etc.), press the Enter button when that menu is highlighted. To return to the System Menu (from the Diagnostics menu, Adjustments menu, etc.) press the Escape button at any time. The following outline shows the System Menu and the next lower level of menus available from the System Menu.

### SYSTEM MENU

#### DIAGNOSTICS

	Switch Edges
	Single Switches
	DIP Switch
	Solenoid Test
	Single Lamp Test
	Lamp Row/Column
	All Lamps
	Video Tests
	Fuse Check

#### ADJUSTMENTS

	Audio Adjustments
	System Adjustments
	Feature Adjustments
	Game Pricing
	High Scores
	Communication

#### BOOKKEEPING

	Main Audits
	Earning Audits
	Standard Audits
	Feature Audits
	Histograms
	Timestamps
	Earnings Charts

#### UTILITIES

	System Information
	Show Shell Window
	Set Location I.D.
	Update Game Code
	Clear Audits
	Clear Coins
	Reset High Scores
	Set Clock
	Factory Adjustments
	Factory Reset
	Install Presets
	Clear Credits

#### PRINTOUTS

	Print Audits
	Print Adjustments
	Print Everything

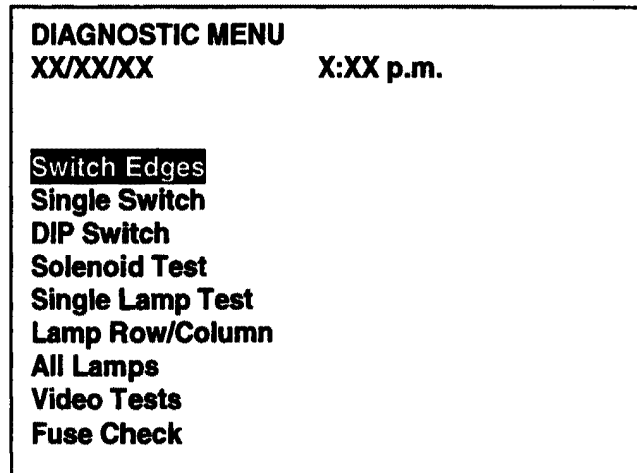
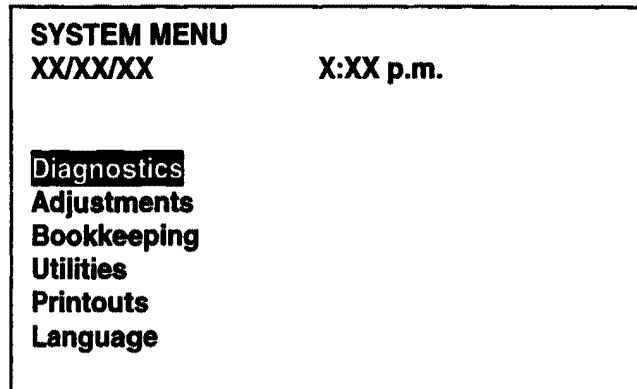
#### LANGUAGE

	English
	Deutsch
	Francais
	Espanol

## DIAGNOSTICS

Open the coin door, press the Enter button and the System Menu appears on the screen. Use the Up and Down buttons to move the cursor and select the Diagnostic menu. Press the Enter button to open the menu when it is selected. Once the Diagnostic menu is open, use the Up and Down buttons to move the cursor and select a test. Press the Enter button to enable the test. Press the Escape button to return to the Diagnostic menu. Press the Escape button a second time to return to the System Menu.

*In order to operate the tests that use the +50V or +20V circuits, pull the interlock switch button out. The interlock switch is located on a bracket in the coin door opening.*



### SWITCH EDGES TEST

Press each of the switches one at a time. The name and number of the switch is on the screen. If a switch other than the one pressed, or no switch at all is indicated, the system has detected a problem with the switch circuit. To return the Diagnostic menu, press the Escape button.

### SINGLE SWITCHES TEST

This test isolates a single switch and shows its state in the display. A mechanical switch is 'made' when the display reads closed. An opto switch is 'made' (opto beam broken) when the display reads open. Use the Up or Down buttons to select the switch to be tested. To return the Diagnostic menu, press the Escape button.

### DIP SWITCH TEST

This test is used to show the positions of the DIP Switches. To return to the Diagnostic menu, press the Escape button.

## **SOLENOID TEST**

The Solenoid test has three modes -- Repeat, Stop, and Run. Only one solenoid should pulse at a time. The system has detected a problem if more than one solenoid pulses, a solenoid comes on and stays on, or no solenoids pulse during the Repeat and Run modes.

**Repeat:** The Repeat mode activates an individual solenoid. Press the Enter button to start this test. The name of the first solenoid shows in the display and the corresponding coil pulses. Press the Up or Down buttons to cycle through the solenoids, one at a time. The same solenoid pulses until you press the Up or Down buttons to advance to the next one. To return the Test menu, press the Escape button. To advance to the next test mode, press the Enter button.

**Stop:** The Stop mode halts the Solenoid test. No solenoids should be active. To return the Test menu, press the Escape button. To advance to the next test mode, press the Enter button.

**Run:** The Run mode cycles through the solenoids automatically. The display shows the name and number of the solenoid currently being pulsed. To return the Test menu, press the Escape button. To return to the Repeat mode, press the Enter button.

## **SINGLE LAMP TEST**

The Single Lamp test checks each lamp circuit individually. Press the Up or Down buttons to scroll through this test. A lamp should light for each name and number that is displayed. Any other results indicate the system has detected a problem. To return to the Diagnostic menu, press the Escape button.

## **LAMP ROW/COLUMN**

This test allows individual rows and columns in the lamp matrix to be operated. This is useful for troubleshooting wiring and driver problems.

Press the Up and Down buttons to cycles through the different rows and columns. To return to the Diagnostic menu, press the Escape button.

## **ALL LAMPS TEST**

This test causes all the controlled lamps to flash at the same time. Every controlled lamp should flash. Any other results indicate the system has detected a problem. To return to the Diagnostic menu, press the Escape button.

## **VIDEO TEST**

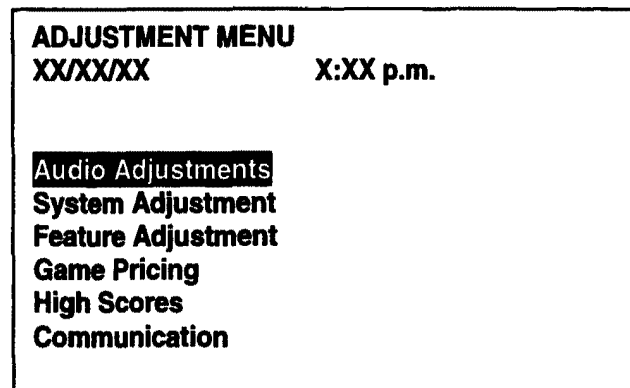
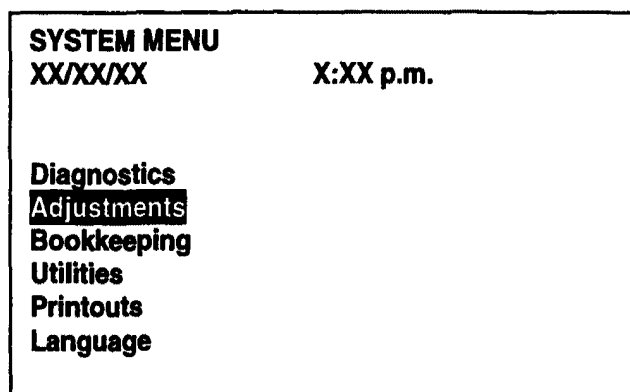
## **FUSE CHECK**

## ADJUSTMENTS

Open the coin door, press the Enter button and the System Menu appears on the screen. Use the Up and Down buttons to move the cursor and select the Adjustment menu. Press the Enter button to open the menu when it is selected. Once the Adjustment menu is open, use the Up and Down buttons to move the cursor and select a sub-menu. Press the Enter button to enable the sub-menu and view the next level of functions.

Use the Up and Down buttons to move the cursor and select a sub-menu function. Press the Enter button to enable that function. Use the Up and Down buttons to change the value. Press the Enter button to lock in the new value, or press the Escape button to retain the original value and return to the sub-menu.

Press the Escape button to return to the sub-menu. Press the Escape button a second time to return to the Adjustment menu and a third time to return to the System Menu.



### AUDIO ADJUSTMENTS

#### **Current Volume**

This adjustment shows the current volume level of the game.

Settings:

Factory Setting: XX

#### **Minimum Volume Override**

The volume can be turned off.

Settings: Yes or No

Factory Setting: No

#### **Volume Interlock**

Settings: Yes or No

Factory Setting: No



## **SYSTEM ADJUSTMENTS**

### **Extra Ball**

This adjustment leads to a menu of adjustments for the Extra Ball feature.

### **Match**

This adjustment lead to a menu of adjustments for the Match feature.

### **Replay**

This adjustment leads to a menu of adjustments for the Replay feature.

### **Power Saver**

This adjustment leads to a menu of adjustments for the Power Saver feature.

### **Clock/Format**

This adjustment leads to a menu of adjustments for the Clock feature.

### **Balls Per Game**

A "game" is defined by specifying the number of balls to be played.

Settings: 1 to 10

Factory Setting: 3

### **Game Restart**

When you press the Start button during or after the 2nd ball, the game in progress ends and a new game begins. This adjustment has three settings to determine how to handle this.

Settings: **Never** – Don't allow a new game start until the current game is over.

**Slow** - Restart if the Start button is pressed continuously for over 1/2 second. This helps to prevent the unintended restart of the game in progress.

**Instantly** - Restart as soon as the Start button is pressed. When you press the Start button during game over, or during the 1st ball (to add a player), it is always handled instantly.

Factory Setting: Slow

### **Tournament Play**

Equalize random game features and global score values during multi-player games.

Settings: Yes or No

Factory Default: No

### **Maximum Tickets per Player**

The amount of tickets each player can earn.

Settings: 00 to 100.

Factory Default: 25

### **Special Award**

The award a player receives when he/she earns a Special.

Settings:

Factory Setting: Credit

### **Slam Tilt Penalty**

Whether of not the player is penalized for causing a Slam Tilt.

Settings: Yes or No

Factory Setting: No

### **Tilt Warning**

The number of total actuation's of the plumb bob that can occur before the game is "tilted".

Settings: 1 to 10

Factory Setting: 3

## **System Adjustments Continued...**

### **Allow Chase Ball**

The Chase Ball feature will attempt to keep a game operational in the event that a ball becomes stuck on the playfield. After a number of unsuccessful ball searches, the game software will end the player's current ball, give a bonus award, then serve a new ball (or end the game if that was the last ball in the player's game). This ball 'chases' the stuck ball on the playfield and will hopefully knock it loose. Setting this adjustment to NO will revert to the previous behavior of searching endlessly until the stuck ball becomes freed, or the machine's power is turned off and back on.

Settings: Yes or No

Factory Setting: Yes

### **Midas Enabled**

This enables the second serial port to work with the Midas Security Unit.

Settings: Yes or No

Factory Setting: No

## **FEATURE ADJUSTMENTS**

### **Bonus Wave Count**

Settings:

Factory Setting: 5

### **Scene Select Timer**

Settings:

Factory Settings: 10

### **Paris Saucer Hits Required**

Settings:

Factory Settings: 10

### **Martian Attack Timer**

Settings:

Factory Setting: 30

### **Capture Multiball Difficulty**

Settings:

Factory Setting: Medium

### **Missile Extra Ball 1**

Settings:

Factory Setting: 20

### **Missile Extra Ball 2**

Settings:

Factory Settings: 70

## **Feature Adjustments Continued...**

### **Disable Martians**

Settings: Yes or No  
Factory Setting: No

### **Disable Left Gate**

Settings: Yes or No  
Factory Setting: No

### **Disable Right Gate**

Settings: Yes or No  
Factory Setting: No

### **Disable Lock Diverter**

Setting: Yes or No  
Factory Setting: No

### **Disable Up/Down Ramp**

Settings: Yes or No  
Factory Settings: Yes or No

### **Disable Jet Exit Post**

Settings: Yes or No  
Factory Settings: No

### **Disable Right Ramp Drop Target**

Settings: Yes or No  
Factory Setting: No

### **Timed Plunger**

This adjustment specifies the number of seconds before automatically plunging a ball onto the playfield that can otherwise be plunged by the player via the launch button.

Settings: Off, 29-90: The number of seconds before automatically plunging the ball.

Factory Setting: Off

## **GAME PRICING**

### **Free Play**

This adjustment determines whether or not the player can play the game for free.

Settings: Yes or No  
Factory Setting: No

### **Maximum Credits**

This is the maximum amount of credits that can be bought at one time.

Settings:  
Factory Setting: 10

### **Hide Coin Audits**

This determines if the coin audits are visible to service personnel.

Settings: Yes or No  
Factory Setting: No

## **HIGH SCORES**

### **Highest Scores**

The game maintains a record of the four highest scores achieved to date.

Settings: Yes or No

Factory Setting: Yes

### **High Score To Date Award**

This is the award given for achieving the High Score to Date or the Champion High Score to Date.

Settings: Credit or Ticket.

Factory Setting: Credit

### **Champion Credit**

The number of credits or tickets awarded for a Grand Champion Score.

Settings: 0 to 10

Factory Settings: 1

### **H.S.T.D. 1 Credits**

### **H.S.T.D. 2 Credits**

### **H.S.T.D. 3 Credits**

### **H.S.T.D. 4 Credits**

The number of credits or tickets awarded whenever a player exceeds the four highest scores.

Settings: 00 to 10

Factory Setting: 1

### **H.S.T.D. Reset Every**

The number of games to be played before an automatic reset of the displayed Highest Score occurs. The operator selects the values provided at reset in the Back-up High Scores.

Settings: OFF (disabled), 250 to 20,000.

Factory Settings: 2000 Games

### **Default Champion**

The Back-up Grand Champion Score.

Settings: 00 to 200,000,000

Factory Settings: 50,000,00

**Default H.S.T.D. 1** **40,000,000**

**Default H.S.T.D. 2** **30,000,000**

**Default H.S.T.D. 3** **20,000,000**

**Default H.S.T.D. 4** **10,000,000**

The first through fourth Default High Score values. The game automatically restores this value when the "High Score Reset Every" value is reached.

Settings: 00 to 200,000,000

Factory Settings: Default H.S.T.D. 1 = 40,000,000

Default H.S.T.D. 2 = 30,000,000

Default H.S.T.D. 3 = 20,000,000

Default H.S.T.D. 4 = 10,000,000

## BOOKKEEPING

*Audits Cannot Be Set, They Can Only Be Cleared.*

Open the coin door, press the Enter button and the System Menu appears on the screen. Use the Up and Down buttons to move the cursor and select the Bookkeeping menu. Press the Enter button to open the menu when it is selected. Once the Bookkeeping menu is open, use the Up and Down buttons to move the cursor and select a sub-menu. Press the Enter button to enable the sub-menu and view the next level of functions.

Use the Up and Down buttons to move the cursor and select a sub-menu function. Press the Enter button to enable that function. Use the Up and Down buttons to reset the value to zero. Press the Enter button to lock in the zero value, or press the Escape button to retain the original value and return to the sub-menu.

Press the Escape button to return to the sub-menu. Press the Escape button a second time to return to the Bookkeeping menu and a third time to return to the System Menu.

```
SYSTEM MENU
XX/XX/XX           X:XX p.m.

Diagnostics
Adjustments
Bookkeeping
Utilities
Printouts
Language
```

```
BOOKKEEPING MENU
XX/XX/XX           X:XX p.m.

Main Audits
Earnings Audits
Standard Audits
Feature Audits
Histograms
Timestamps
Earnings Charts
```

## MAIN AUDITS

No Main Audits at this time.

## EARNING AUDITS

Total Earnings	XX	Recent Slot 6	XX
Recent Earnings	XX	Recent Slot 7	XX
Recent Paid Credits	XX	Recent Slot 8	XX
Total Paid Credits	XX	Total Slot 1	XX
Recent Service Credits	XX	Total Slot 2	XX
Total Service Credits	XX	Total Slot 3	XX
Recent Slot 1	XX	Total Slot 4	XX
Recent Slot 2	XX	Total Slot 5	XX
Recent Slot 3	XX	Total Slot 6	XX
Recent Slot 4	XX	Total Slot 7	XX
Recent Slot 5	XX	Total Slot 8	XX

**STANDARD AUDITS**

Games Started	XX	Right Drains	XX	XX%
Total Plays	XX	Game Tilts	XX	
Average Game Time	XX	Slam Tilts	XX	
Balls Played	XX	Plumb Bob Tilts	XX	
Average Ball Time	XX	Ball Roll Tilts	XX	
Extra Balls	XX XX%	1 Player Games	XX	
Tickets Awarded	XX XX%	2 Player Games	XX	
Match Awards	XX XX%	3 Player Games	XX	
Total Replay Awards	XX XX%	4 Player Games	XX	
Replay 1 Awards	XX XX%	Ball Searches	XX	
Replay 2 Awards	XX XX%	Ball Searches (5)	XX	
Replay 3 Awards	XX XX%	Chase Balls	XX	
Replay 4 Awards	XX XX%			
Left Drains	XX XX%			

**FEATURE AUDITS**

Fuel Started	XX	Paris in Peril Started	XX
Saucer Started	XX	Big-O-Beam Started	XX
Weapons Started	XX	Mars Kneads Women Started	XX
Alien Abduction	XX	Tower Struggle Started	XX
Martian Happy Hour Started	XX	Question Mark Started	XX
Secret Weapon Started	XX	Drive-in Demolition Started	XX

**HISTOGRAMS**

Score Histograms  
Ball Histograms

**TIMESTAMPS**

Total Uptime	XX
Current Uptime	XX
System Downtime	XX
Last Game Start	XX
Last Service Credit	XX

**EARNINGS CHARTS**

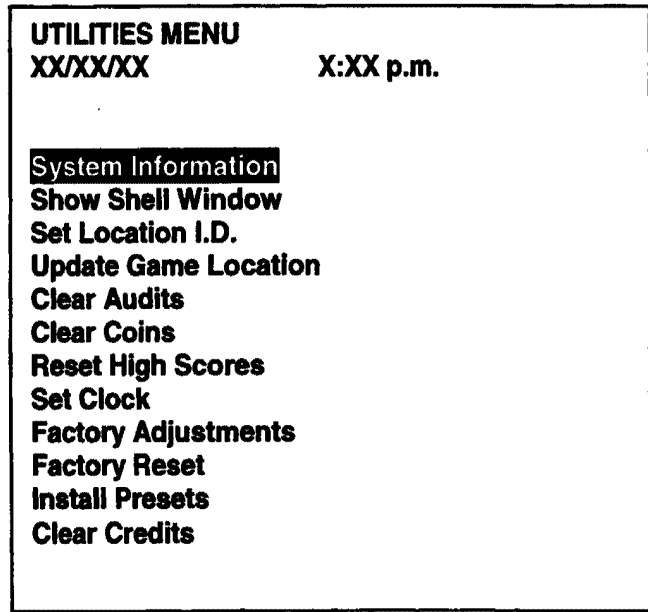
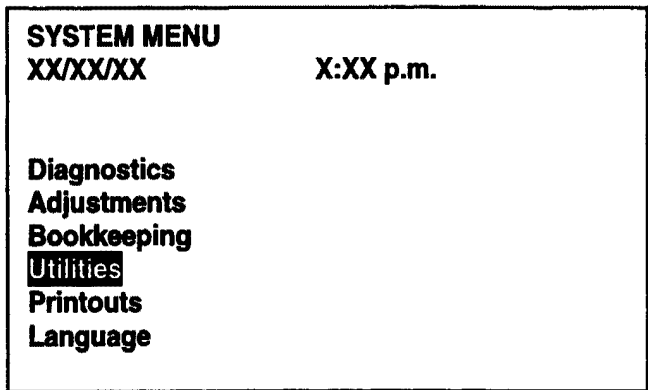
Last 24 Hours  
Last 21 Hours  
Last 21 Days  
Last 12 Hours

## UTILITIES

Open the coin door, press the Enter button and the System Menu appears on the screen. Use the Up and Down buttons to move the cursor and select the Utilities menu. Press the Enter button to open the menu when it is selected. Once the Utilities menu is open, use the Up and Down buttons to move the cursor and select a function. Press the Enter button to enable the function.

Use the Up and Down buttons to change the function setting. Press the Enter button when the desired setting is displayed and a 'countdown' screen appears. Press the Enter button during the 'countdown' to lock in the new setting. Or, wait for the 'countdown' to complete and the new setting is locked in automatically. Press the Escape button, during the 'countdown' to retain the original setting and return to the Utilities Menu.

Press the Escape button to return to the Utilities menu. Press the Escape button a second time to return to the System Menu.



### SYSTEM INFORMATION

The System Information utility displays game specifications. It cannot be cleared.

### SHOW SHELL WINDOW

This is used to show the system terminal window. It is for diagnostic use.

## **SET LOCATION I.D.**

This utility allows the operator to show the game's location on printouts. Press the Enter button to open the utility. Use the Up and Down buttons to move the cursor and select letters. Press the Enter button to lock in desired letters.

## **UPDATE GAME CODE CODE (You will typically want to run the latest update).**

Use this menu to enable or disable the update game code (stored in the PRISM board FLASH memory).

### **Enable Updated Code**

If the update game code is enabled, the system will run the last version of update game code installed (REFERENCE SOFTWARE UPDATES IN NEW FEATURES OF PINBALL 2000).

### **Disabled Updated Code**

If the update game code is disabled, the system will run the version of game code located in the original PRISM board ROMs.

## **WARNING TO THE OPERATOR.**

**In early releases of the Revenge from Mars game code ROMs, DO NOT perform the Disabled Updated Code. Doing so will cause your game to run in Free Only Mode and the UPDATE GAME CODE utility menu will not allow the updated game code to be enabled.**

If you accidentally disable the update game code, do one of the following:

- 1) Plug a keyboard into the keyboard port (located near the computer case in the backbox) or,
- 2) Plug a computer terminal into the COM 1 port (located near the coin door).

Then, at the command (%) prompt type the following:

```
% fupdate enable
```

to re-enable the Updated Game Code.

Note: This operation takes about 15 seconds to complete.

## **CLEAR AUDITS**

Press the Enter button to clear the all of the audits.

## **CLEAR COINS**

Press the Enter button to clear the Earnings Audits.

## **RESET HIGH SCORES**

Press the Enter button to clear the High Score to Date Table.

## **SET CLOCK**

Press the Enter button to activate the clock. Use the Up and Down buttons to change the time, then press the Enter button to lock in the time.

## **FACTORY ADJUSTMENT**

Press the Enter button to restore the adjustments to factory settings.

## **FACTORY RESET**

Press the Enter button to restore the adjustments to their factory setting, clear the Audits, Reset the High Score, and the Location I.D.

## **INSTALL PRESETS**

Press the Enter button to open the utility. Use the Up and Down buttons to move the cursor and select from the available Presets. When the desired Preset is selected, press the Enter button to lock it in. Press the Escape button, during the 'countdown' to retain the original setting and return to the Utilities Menu.

## **CLEAR CREDITS**

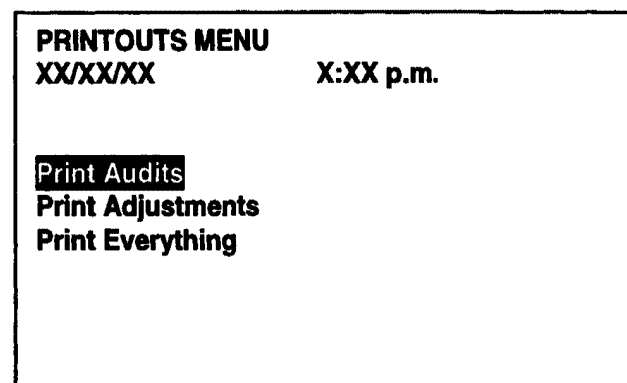
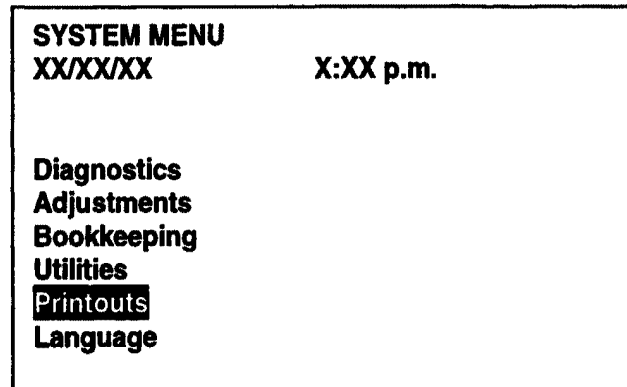
Press the Enter button to clear the game Credits.



## PRINTOUTS

Open the coin door, press the Enter button and the System Menu appears on the screen. Use the Up and Down buttons to move the cursor and select the Printouts menu. Press the Enter button to open the menu when it is selected. Once the Printouts menu is open, use the Up and Down buttons to move the cursor and select a function. Press the Enter button to enable the function.

Press the Escape button to return to the Printouts menu. Press the Escape button a second time to return to the System Menu.



### PRINT AUDITS

Print all System Audits.

### PRINT ADJUSTMENTS

Print a record of all System Adjustments. A \*\*\* signifies a changed adjustment.

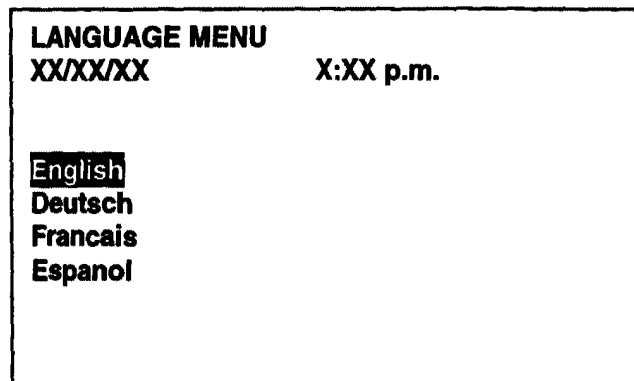
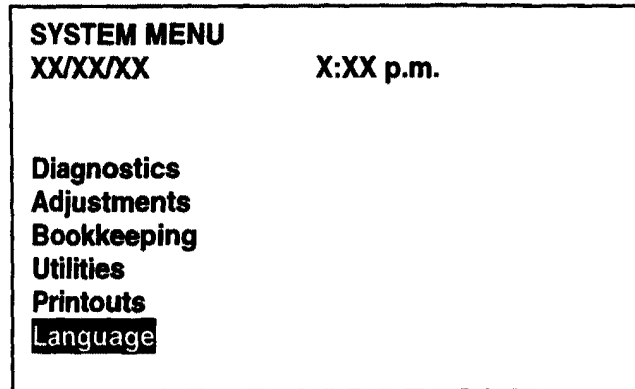
### PRINT EVERYTHING

Print both audits and adjustments.

## LANGUAGE

Open the coin door, press the Enter button and the System Menu appears on the screen. Use the Up and Down buttons to move the cursor and select the Language menu. Press the Enter button to open the menu when it is selected. Once the Language menu is open, use the Up and Down buttons to move the cursor and select a language. Press the Enter button to enable that language.

Press the Escape button to return to the Language menu. Press the Escape button a second time to return to the System Menu.



## ROUTINE MAINTENANCE INFORMATION

### ◆ CLEANING

Good game action and extended playfield life are the results of regular playfield cleaning. During each collection stop, the playfield glass should be removed and thoroughly cleaned using only a non-abrasive sprayed liquid glass cleaner and a soft cloth. The playfield should be wiped off with a clean, lint-free cloth. The game steel balls should be cleaned and inspected for any chips, nicks, or pits. Replace any damaged balls to prevent playfield damage.

Regular, more extensive, playfield cleaning is recommended. However, avoid excessive use of water and caustic or abrasive cleaners because they tend to damage the playfield surface. Playfield wax (or any carnauba based wax), or polish may be used sparingly, to prevent a buildup on the playfield surface. Do not use cleaners containing petroleum distillates on any playfield plastics because they may dissolve the plastic material or damage the artwork.

### ◆ GLASS PARTS

Wear protective gloves and use both hands when carrying or moving parts made of glass. Glass pieces can fly eight feet (two meters) or more from the point of impact.

---

## SERVICE INFORMATION

**Only trained personal should service the game. Always turn off power and unplug the game before attempting any service!**

### ◆ HIGH VOLTAGE CONSIDERATIONS

CRTs and their power supplies can retain energy for long periods of time after the power has been turned off. This is especially true when a defective circuit prevents a normal discharge. Connect a very well insulated ground strap to the metal chassis. Slide the free end of the strap under the CRT anode cap until contact is made. Wait two minutes for charge recovery, then discharge the anode a second time.

### ◆ RADIATION

The high voltages used in the Video Monitor Assembly are capable of generating X-rays under fault conditions. Do not substitute high voltage components or modify the circuit without factory authorization. Follow the manufacturer's directions for measuring and adjusting the CRT anode voltage.

### ◆ BATTERY

Note the position of the battery. Gently lift the contact arm to release tension. Do not bend the arm. Slide the battery out of it holder. To reinstall the battery, orient the cell near the holder and slide it under the contact arm. Do not force the battery into the holder.



### CAUTION

Danger of explosion if battery is incorrectly replaced. Replace with only the same or equivalent type recommended by manufacturer. Do not attempt to recharge these batteries. Avoid direct shorts across terminals or from terminals to ground. Dispose of used batteries according to manufacturer's instructions.

◆ **MEMORY**

The ROM chips contain the computer operating instructions. Memory devices are very sensitive to static charges. Use grounding precautions when handling these parts.

To remove a ROM chip from its socket, carefully note its position and then lift the chip using a chip extraction tool. To reinstall a ROM, place the chip over its socket so that the notch in the chip lines up with the silkscreen on the board, and press down firmly to seat. Do not force the chip into the socket. Do not bend the pins under the chip.

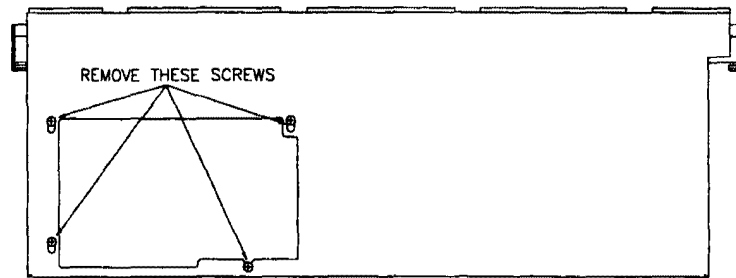


**CAUTION**

Use wrist straps, conductive mats or other methods of safely discharging static electricity. Hold all integrated circuits by their packages and not by the metal pins. Extractor and insertion tools are recommended to avoid bent or broken pins caused by excessive force.

◆ **POWER SUPPLY**

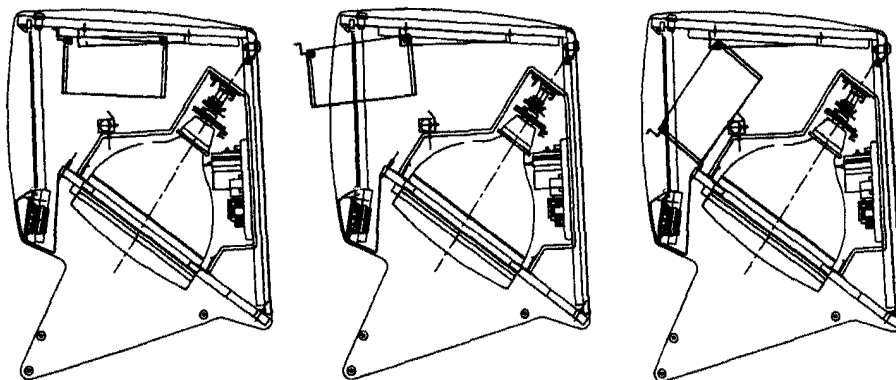
Unlock and remove the backbox rear door. Unplug the IEC cord and remove the four outer screws surrounding the power supply that secure it to the case. See the drawing below.



**Rear view of the computer case**

Unlock and remove the backglass and the translite. Unscrew the two screws on either side of the power switch. Grasp the computer case from the front and slide it toward you. Let it hang in front of the backbox, see the drawing below.

SLIDE THE COMPUTER CASE FORWARD AND REST IT ON THE MONITOR BRACKET.



**Side View of Backbox**

Open the top of the computer case. Unplug the cable harnesses leading from the power supply; one plug is going to one connector on the power amp and two plugs are going to one connector on the CPU board. Lift the power supply out of the computer case.

**NOTICE**

Always replace the computer case cover. Failure to do so will void FCC, UL and CE compliance, and may cause damage to the PC boards in the case. The foam lining of the cover holds the PC boards securely in place and protects them from vibrations that normally occur in a pinball game.

◆ **GLASS PARTS**

Wear protective gloves and use both hands when carrying or moving parts made of glass. Fluorescent tubes and CRTs will usually implode if broken. Glass pieces can fly eight feet (two meters) or more from the point of impact.

◆ **FLUORESCENT TUBE, STARTER, OR FLUORESCENT LIGHT ASSEMBLY**

Remove the backglass and translite. Remove both plastic lamp locks. Grasp the bulb at each end and give it a quarter turn. Gently pull the bulb straight out to remove it from its socket. The starter also requires a quarter turn for removal. Do not force the bulb or starter during reinstallation. Clean the bulb to remove fingerprints and dust, then reinstall the translite and backglass.

To remove the entire light fixture, remove the lamp locks and the bulb as described above. Disconnect the fluorescent light assembly connector from its power cable. Remove the screws that hold the assembly to the cabinet, then lift out the assembly.

**If you drop a fluorescent tube or a CRT and it breaks, it will implode! Use care in handling.**

◆ **CIRCUIT PROTECTION**

To avoid equipment damage, any replacement fuse must match the original in fuse type, voltage rating, and current rating. Do not use fuses with different time delay characteristics.

◆ **MONITOR**

Unlock and remove the backbox rear door. Disconnect all of the cables going to the monitor. Remove the four flange nuts securing the monitor's mounting brackets to its mounting panel. **CAREFULLY**, Pull the monitor from the backbox. Clean the face of the monitor before reinstalling it.



**CAUTION**

THE VIDEO MONITOR IS HEAVY, WITH MOST OF THE WEIGHT TOWARD THE FRONT OF THE ASSEMBLY. Be sure it is firmly supported as it is removed from the cabinet. The monitor does require isolation from the A.C. line voltage in normal operation. When operating outside the backbox or servicing the monitor on a test bench, **YOU MUST ISOLATE THE MONITOR FROM LINE VOLTAGE WITH A TRANSFORMER. THE MONITOR MUST BE POWERED AT 110V.**

◆ **LUBRICATION**

The two main lubrication points of the Ball Release mechanism are the pivots for the arm. The mechanisms of other playfield devices are somewhat similar to the Ball Release, and have the same lubrication requirements. A medium viscosity oil (switch target grease) is satisfactory for these devices.

Because of the functional design (arm-actuated via solenoid plunger operation), the pivot points of the Left and Right Kickers ("Slingshots") all require lubrication as a regular servicing procedure. Lubrication to ensure proper operation also applies to the target blades of the Drop Targets. MBI Instrument Grease, also known as Drop Target Switch Lubricant, with a Williams' part number of EI165, is a recommended lubricant.

◆ **SWITCH CONTACTS**

**Playfield Switches.** For proper game operation, switch contacts should be free of dust, dirt, contamination, and corrosion. Blade switch contacts are plated to resist corrosion. Cleaning blade switch contacts requires gentle closing of the contacts on a clean business card or piece of paper, and then pulling the paper about 2 inches, which should restore the clean contact surface. Adjust the switch contacts to a 1/16-inch gap.

### ***Switch Contacts Continued...***

**Flipper Switches.** This game uses the Fliptronic II Electronic Flipper System. The End-of-Stroke switches are NORMALLY OPEN. The switch should close when the flipper is energized. All E.O.S. switches are gold flashed computer grade leaf switches. Only low computer current is carried through these switches. DO NOT FILE or abrasively clean these switches! DO NOT REPLACE these switches with the tungsten high current switches, as intermittent operation could occur.

**NOTE:** *Unlike the old style of flipper, an E.O.S. switch failure does not harm the flipper. The game notifies the operator that the switch is misadjusted in the test report, but continues to play. The E.O.S. switches are a means by which the new electronic flippers feel and play with all of the subtleties of the old flippers.*

## **EPILEPSY WARNING**

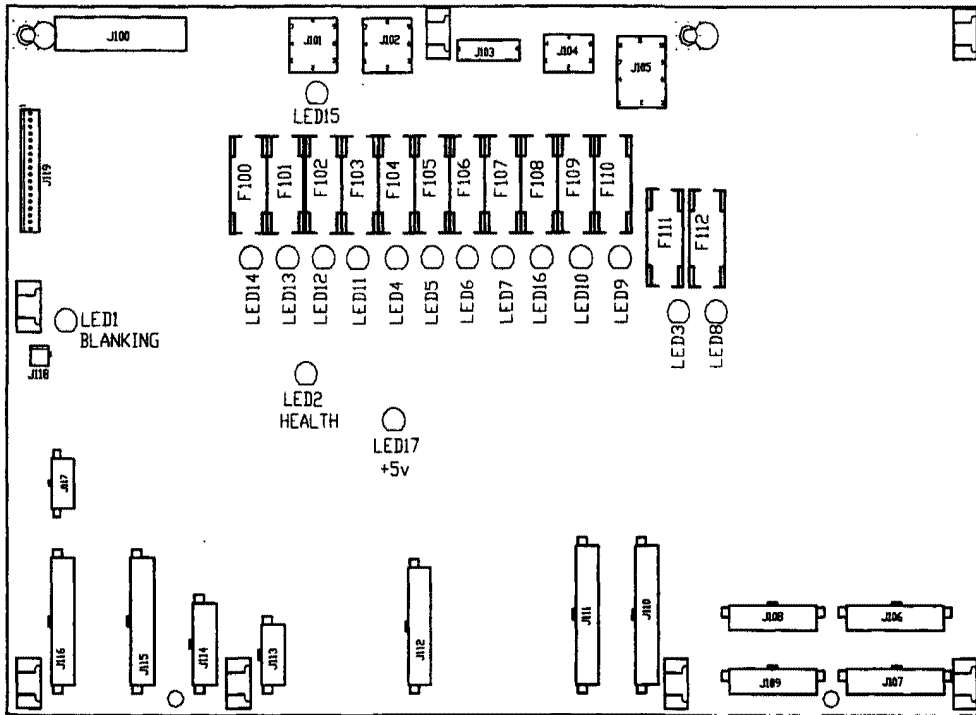
A very small portion of the population has a condition which may cause them to experience epileptic seizures or have momentary loss of consciousness when viewing certain kinds of flashing lights that are present in our daily environment. These persons may experience seizures while watching some kinds of television pictures or playing certain video games. People who have not had any previous seizures may nonetheless have an undetected epileptic condition.

If you or anyone in your family has experienced symptoms linked to an epileptic condition (e.g., seizures or loss of awareness), immediately consult your physician before using any video games.

We recommend that parents observe their children while they play video games. If you or your child experience the following symptoms: dizziness, altered vision, eye or muscle twitching, involuntary movements, loss of awareness, disorientation, or convulsions, DISCONTINUE USE IMMEDIATELY and consult your physician.

# LED AND FUSE LIST

## POWER DRIVER BOARD



### LED LIST

<b>LED 1</b>	Watchdog	<b>LED 10</b>	+20V Flashlamps
<b>LED 2</b>	Health	<b>LED 11</b>	Solenoid Power 1
<b>LED 3</b>	+18V Lamp Matrix A	<b>LED 12</b>	Solenoid Power 2
<b>LED 4</b>	+50V Lower Right Flipper	<b>LED 13</b>	Solenoid Power 3
<b>LED 5</b>	+50V Lower Left Flipper	<b>LED 14</b>	Solenoid Power 4
<b>LED 6</b>	+50V Upper Right Flipper	<b>LED 15</b>	+20V
<b>LED 7</b>	+50V Upper Left Flipper	<b>LED 16</b>	+12V
<b>LED 8</b>	+18V Lamp Matrix B	<b>LED 17</b>	+5V
<b>LED 9</b>	+50V Solenoids		

### FUSE LIST

Loc.	Value	Part Number	Description
<b>F100</b>	T4.0A 250V	5371-14530-00	Solenoid Power 4
<b>F101</b>	T4.0A 250V	5371-14530-00	Solenoid Power 1
<b>F102</b>	T4.0A 250V	5371-14530-00	Solenoid Power 2
<b>F103</b>	T4.0A 250V	5371-14530-00	Solenoid Power 3
<b>F104</b>	T4.0A 250V	5371-14530-00	Lower Right Flipper Power
<b>F105</b>	T4.0A 250V	5371-14530-00	Lower Left Flipper Power
<b>F106</b>	T4.0A 250V	5371-14530-00	Upper Right Flipper Power
<b>F107</b>	T4.0A 250V	5371-14530-00	Upper Left Flipper Power
<b>F108</b>	T4.0A 250V	5371-14530-00	12VAC Unregulated
<b>F109</b>	T4.0A 250V	5371-14530-00	20VAC Flashlamps
<b>F110</b>	T6.3A 250V	5731-14529-00	50VAC Solenoids
<b>F111</b>	T5.0A 250V	5731-14046-00	18VAC Lamp Matrix A
<b>F112</b>	T5.0A 250V	5731-14046-00	18VAC Lamp Matrix B

### LINE FUSE

Location	Value	Part Number
Foreign	T4.0A 250V	5731-14530-00
Domestic	T5.0A 250V	5731-14046-00



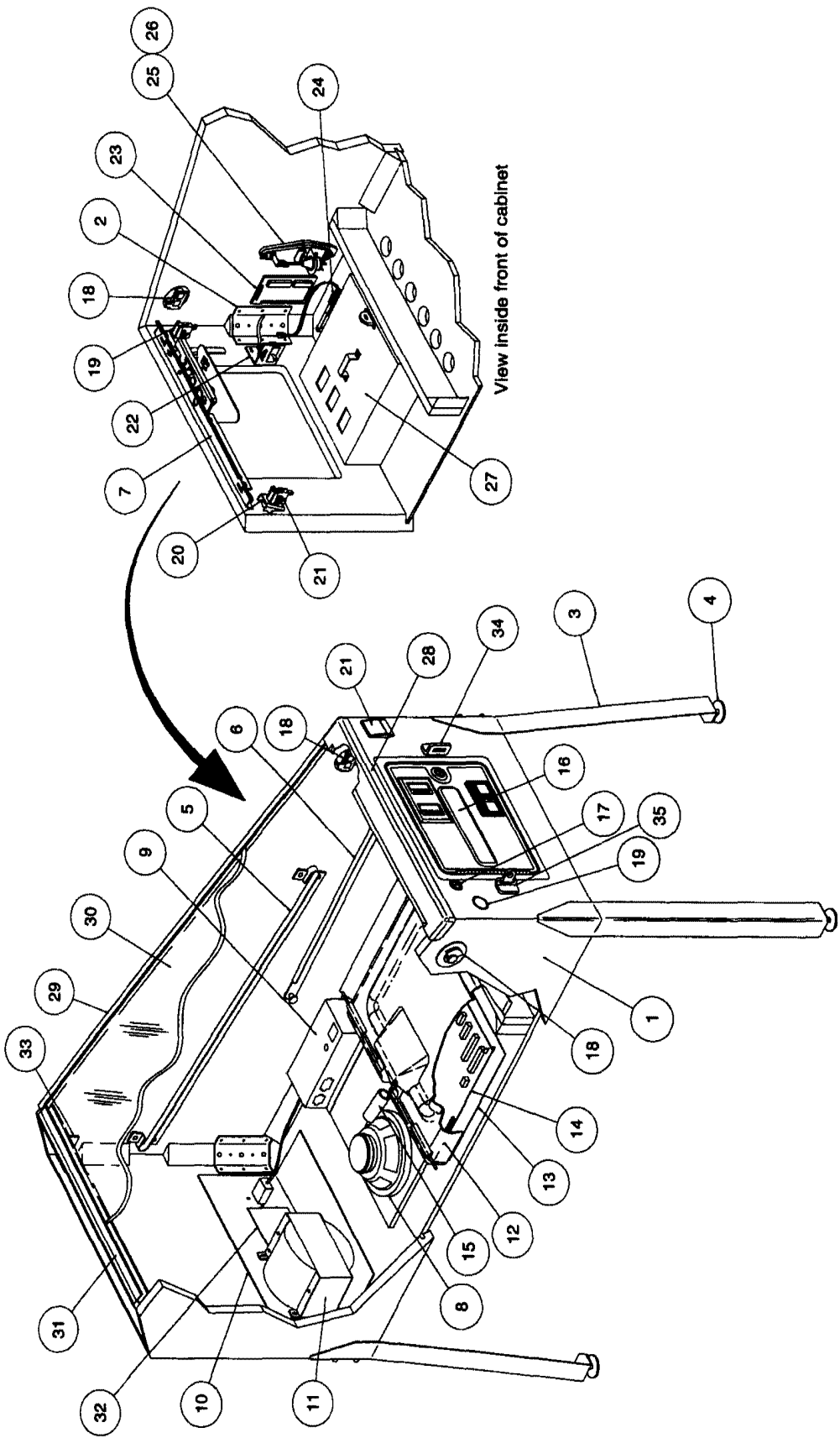


# **SECTION TWO**

## **PARTS INFORMATION**

**Items listed as Associated Parts are not sold as part of the main assembly.  
Associated Parts are only sold separate.**

# 50070-CAB Cabinet Assembly



**50070-CAB**

# Cabinet Assembly Parts List

<u>Item</u>	<u>Part Number</u>	<u>Description</u>
1	04-12480.4	Cabinet
2	01-11400-1	Leg Mounting Bracket (x4)
3	A-19514-6	Leg Assembly – Black Ridge (x4)
4	08-7377	Leg Leveler/Adjuster (x4)
5	01-15132-1	Playfield Slide Track – Right
6	04-12610	Stay Arm
7	A-22996	Lockdown Bracket Assembly
8	5555-16059-00	Speaker, 6.5" Woofer, 4Ω
9	A-22966	Power Control Box Assembly
10	04-12596.1	Drip Plate
11	5610-15930-00	Transformer Assembly
12	A-22998	Driver Board Cover Assembly
13	A-23299	Driver Board Back Plate Assembly
14	04-12329	Power Driver Board PCB Assembly
15	03-10011	Cover Stop Tube
16	09-96032-33	Coin Door – USA
17	20-10690	Hand Molding Lock
18	A-22984	Flipper Button Assembly (x2)
19	20-10696	Push Button w/Switch – <i>START</i> (Yellow)
20	01-15184	Launch Button Bracket
21	20-10692-1	Push Button w/Switch – <i>LAUNCH</i> (Red)
22	A-23024	Coin Door Interlock Switch Assembly
23	A-22964	Coin door Interface PCB Assembly & Spacer
24	A-17195-2	Tilt Switch Assembly w/Cable
25	04-10346.1	Tilt Mechanism Assembly
26	20-6502-A	Plumb Bob
27	A-23139	4-Ball Cash Box Assembly
28	A-22997	Hand Molding Assembly
29	A-22976-1	Side Molding Assembly (x2)
30	04-12739.1	Tinted Playfield Glass Assembly
31	03-8091	Rear Molding
32	01-15214	Hole Cover
33	01-15212	Cabinet Corner Bracket
34	01-14085.1	Hasp Hinge Bracket
35	01-14086.1	Hasp Staple Bracket

**Miscellaneous Parts:** (Not Shown)

<u>Part Number</u>	<u>Description</u>
01-15132-2	Playfield Slide Track – Left
04-12628.2	Safety Pin Bracket
01-15136-1-2	Lock Plate
*	Cordset
20-6500	Steel Ball, Ø1-1/16" (x4)
01-6389-1	Cash Box lock Bracket
01-12352	Clip Bracket
4322-1125-40	3/8 x 16 Hex Acorn Head Leg Bolt
01-14084.2	Slotted Hasp Plate

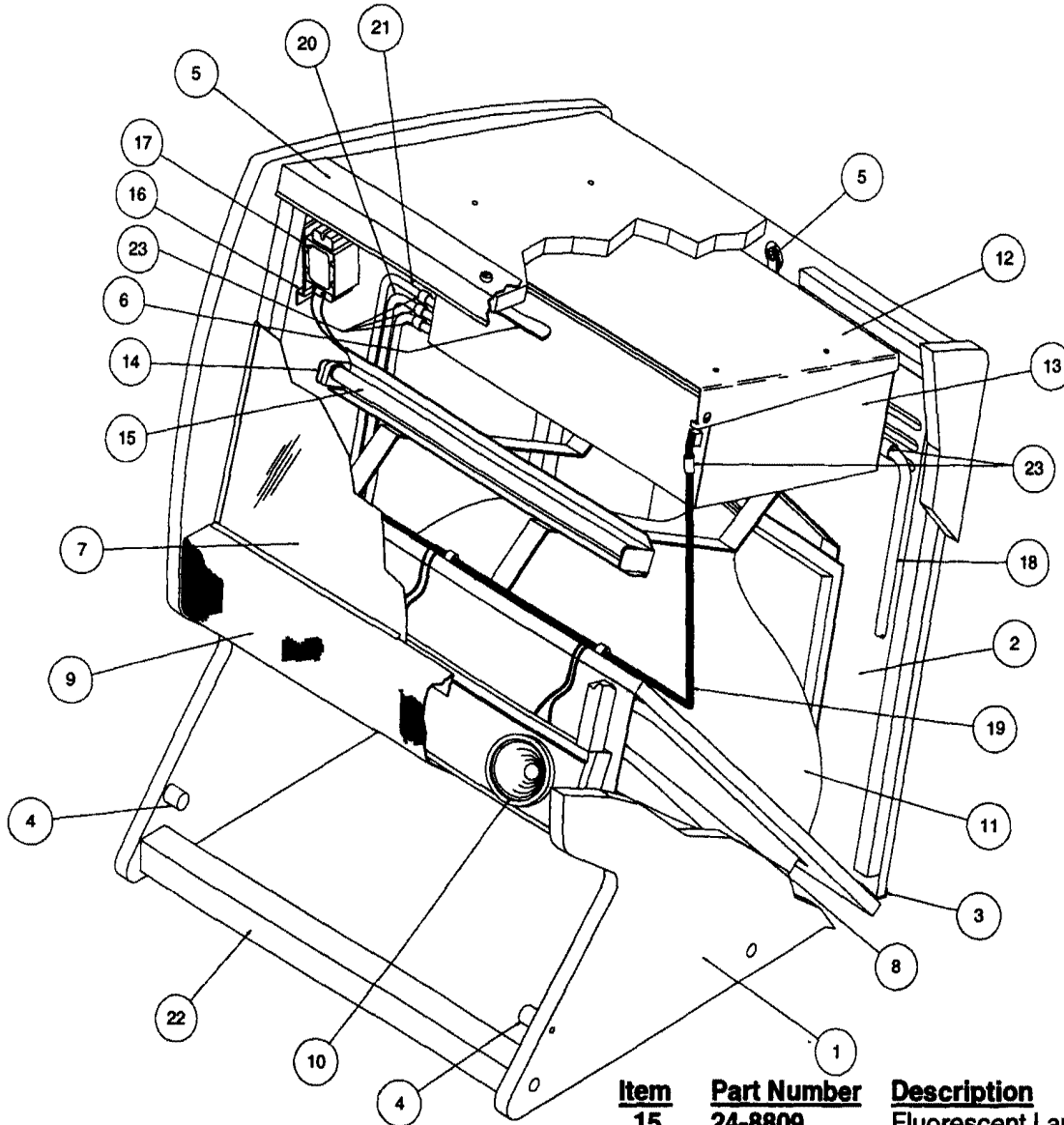
**Cabinet Cables:**

<u>Part Number</u>	<u>Description</u>
H-22740-2.1	Cabinet Cable
H-22740-1.2	Cabinet Cable
H-22736	Secondary power Cable
H-22737-2	Cabinet Power/Speaker Cable
H-22955	Cabinet Switch/Lamp Cable

---

\* See Power Interface/Cordset Application Chart on page 2-31

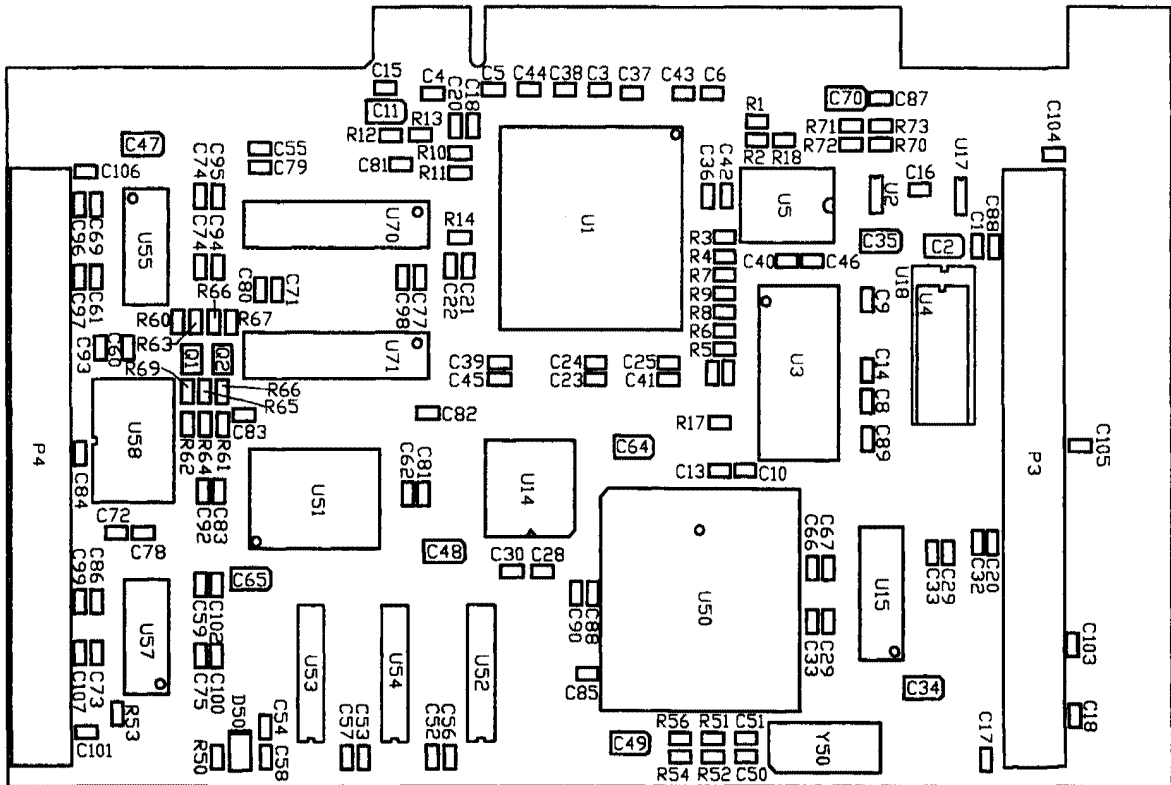
# 50070-BB Back Box Assembly



<u>Item</u>	<u>Part Number</u>	<u>Description</u>	<u>Item</u>	<u>Part Number</u>	<u>Description</u>
1	04-12489.4	Back Box	15	24-8809	Fluorescent Lamp 15W, 18"
2	A-22982	Back Door Assembly	16	04-12752	Ballast Mounting Bracket
3	01-15131	Door Channel	17	A-23155	Ballast Assembly
4	03-9992	Knob	18	A-23160	CPU/AC Power Cable
5	A-22981	Lock & Plate Assembly	19	H-22737-1	AC/Speaker Cable
6	01-15134	Front Lock Cam	20	20-10583	Extension Cable db09 – 10ft
7	A-22975-50070	Marquee Assembly	21	20-10584	Extension Cable db25 – 10ft
8	04-12607.1	Speaker Grill Bracket			
9	04-12606.1	Speaker Grill			
10	5555-16223-00	Speaker - 4Ω, 25W			
11	5675-16058-02	Monitor – 19"			
12	01-15130.2	Computer Case Mounting Bracket			
13	A-22724	Computer Case Assembly			
14	A-22980	Fluorescent Lamp Assembly			
			<b>Miscellaneous Parts:</b>		
			<u>Item</u>	<u>Part Number</u>	<u>Description</u>
			22	11-1464	Back Box Shipping Brace
			23	5556-15272-00	Ferrite
			*24	02-4352-2	Pivot Bushing
			*25	4322-10228-12	CS 3/8-16 x 3/4 Button Head – Nylon Patch
			*26	4700-00111-00	FW .390 x .875 x .062

\* Item not shown

# 04-12602 Prism PCB Assembly



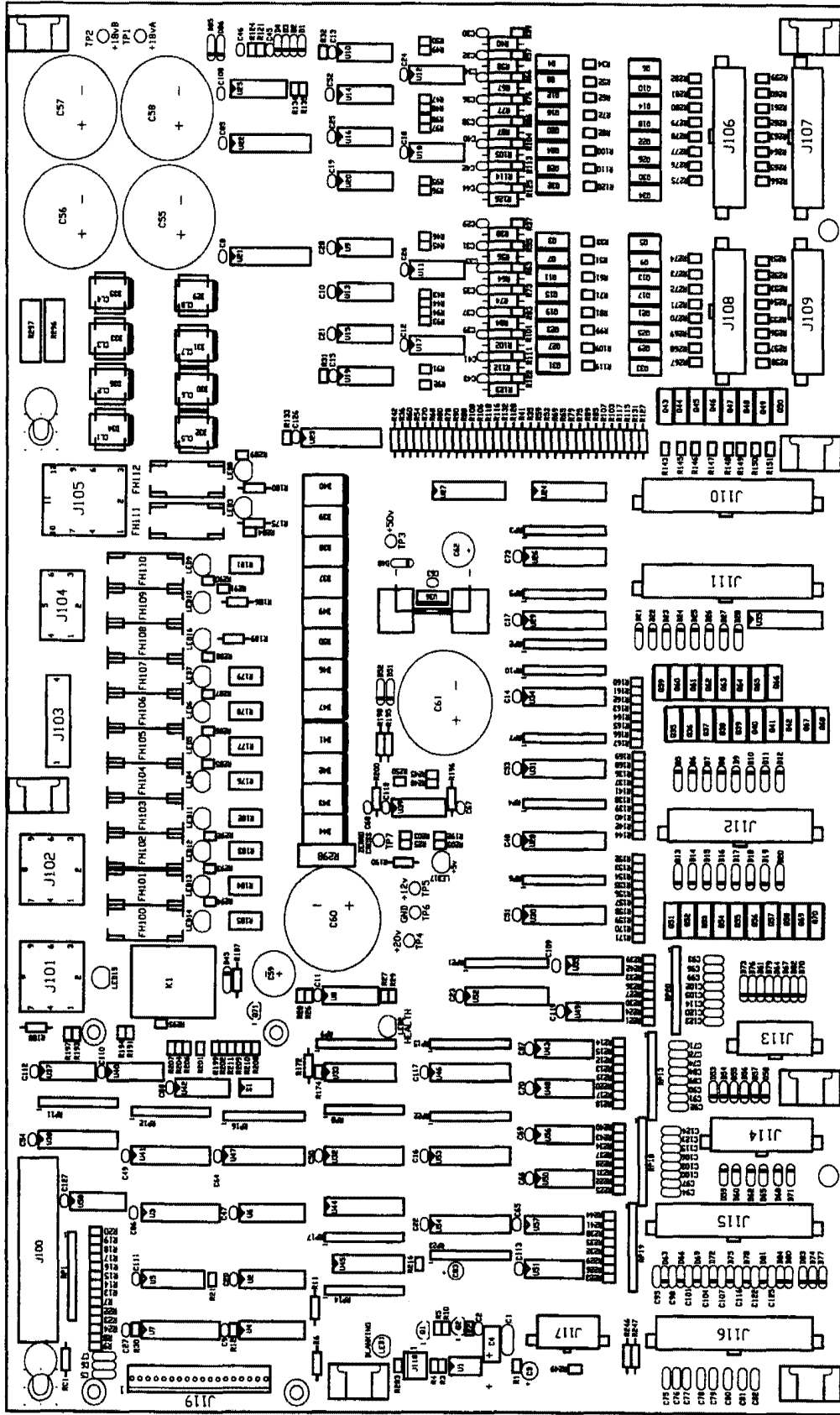
**Designator**

R1-R14, R17, R18, R52-R54, R56, R65, R66,  
R69-R73  
R50  
R62, R63, R64, R67, R68  
C2, C11, C34, C35, C47, C48 C49, C64, C65, C70  
C50, C51  
C1, C7-C10, C17, C19, C21 C24-C29, C36-C40,  
C52-C55, C67, C90-C100  
C3-C6, C12-C16, C20, C22, C23, C41-C46,  
C101-C107  
C18, C30-C33, C56-C63, C66, C68, C69, C78-C89  
Q1, Q2  
U15  
U55, U57  
U4  
U2  
U58  
U3  
U5  
U17  
U50  
U51  
U52, U53, U54  
U1  
U14  
Y50  
D50  
P3, P4

**Part Number**

**5020-14156-00** Resistor, 10K $\Omega$ , 5%, 1/10W, R0805  
  
**5020-14160-00** Resistor, 330 $\Omega$ , 5%, 1/10W, R0805  
**5020-14152-00** Resistor, 100 $\Omega$ , 5%, 1/10W, R0805  
**5051-14151-00** Capacitor, 10 $\mu$ f, 16V  $\pm$ 20%, SMD TANT  
**5052-14149-00** Capacitor, 22pf, 100V 10%, SMD  
**5052-14164-00** Capacitor, .01 $\mu$ f, 50V 20%, SMD  
  
**5052-14165-00** Capacitor, .1 $\mu$ f, 50V 20%, SMD Z5U  
  
**5052-14368-00** Capacitor, 22pf, 100V 10%, SMD  
**5160-16056-00** Transistor, NPN 2N3904 SC70  
**5283-16051-00** IC, Bus Transceiver, 74FCT162543T  
**5285-14601-00** IC, 74FCT162245  
**5340-16204-00** IC, SRAM, 32K x 8, 70ns, SOP28  
**5345-16049-00** IC, EE Serial PROM  
**5345-16053-00** IC, Flash 8Mbit TSOP48  
**5345-16196-00** IC, Flash EEPROM, 28F320J5 SSOP  
**5521-16050-00** OSC, 30MHz SMT  
**5432-16052-00** IC, NVRAM Controller SOIC8  
**5400-15450-00** ADSP-2104KP-40  
**5410-14590-00** IC, SDR ASIC Video  
**5349-14606-00** IC, SRAM, 32K x 8 - 15, 28PSOJ  
**5430-16048-00** IC, PCI Bus Interface, PCI9502  
**A-23290** IC, CPLD U14 Assembly  
**5520-16054-00** OSC, 16MHz Crystal SMT  
**5671-14653-00** LED, Yellow SMD  
**5792-16057-00** Connector, Dual Row 2 x 40 SMT

# 04-12329 Power Driver Board



04-12329

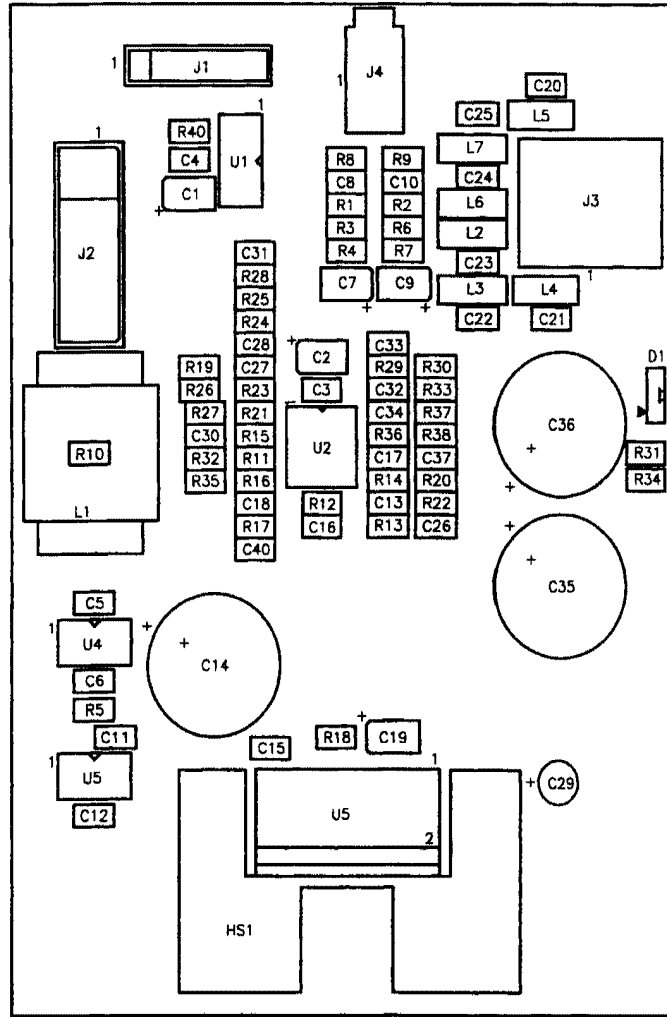
# Power Driver Board Parts List

Part Number	Description	Designator
5043-08996-00	Capacitor, 0.1 $\mu$ f, 50V $\pm$ 20% Axial	C1, C2, C8-C54, C63-C70, C73, C85-C88, C108-C113, C117-C119, C126, C127
5040-13098-00	Capacitor, 4.7 $\mu$ f, 35V $\pm$ 20%	C3, C83
5040-09365-00	Capacitor, 1 $\mu$ f, 63V +50%-10% Axial	C4
5048-11029-00	Capacitor, 100pf 50V $\pm$ 5% Axial	C5-C7
5040-15413-00	Capacitor, 1000 $\mu$ f, 35V, 25mm	C55-C58, C60, C61
5040-09537-00	Capacitor, 100 $\mu$ f, 100V $\pm$ 20% Radial	C59
5040-13102-00	Capacitor, 470 $\mu$ f, 35V $\pm$ 20% Radial	C62
5048-11030-00	Capacitor, 470pf, 50V Axial	C71, C72, C74-C82, C84, C89, C90-C107, C114-C116, C120-C125
5070-08919-00	Diode, 1N4148, 150mA	D1-D4, D53-D84
5070-09054-00	Diode, 1N4004, 1.0A	D5-D28, D45, D48, D51, D52
5070-14526-00	Diode, P600G, 6A, 400 PIV	D29-D44, D46, D47, D49, D50
5733-14528-00	Fuse Holder, 5x20mm, 10A	FH100-FH112
5731-14530-00	Fuse, 5x20mm, T4A, 250V	F100, F101, F102, F103, F104, F105, F106, F107, F108, F109
5731-14529-00	Fuse, 5X20mm, T6.3A, 250V	F110
5731-14046-00	Fuse, 5x20mm, SB T5A	F111, F112
5705-14562-00	Heatsink, 10-220 Wave Sol 287	HS1
5791-16065-00	25 Pin D-SUB Connector, R/A PCB Mount	J100
5792-13223-09	9 Pin Female, .084 MLX	J102, J101
5792-13223-04	4 Pin Female, .084 MLX	J103
5792-13223-06	6 Pin Female, .084 MLX	J104
5792-13223-12	12 Pin Female, .084 MLX	J105
5791-13356-18	Header-PCB Mount, 0.165 center 18P	J106, J107
5791-13356-16	Header-PCB Mount, 0.165 center 16P	J108, J109
5791-13356-24	Header-PCB Mount, 0.165 center 24P	J110, J111
5791-13356-20	Header-PCB Mount, 0.165 center 20P	J112
5791-13356-10	Header-PCB Mount, 0.165 center 10P	J113
5791-13356-14	Header-PCB Mount, 0.165 center 14P	J114
5791-13356-22	Header-PCB Mount, 0.165 center 22P	J115, J116
5791-13356-08	Header-PCB Mount, 0.165 center 8P(N)	J117
5791-13830-03	3H Straight Square Pin, .100 Solid Tab	J118
5792-15928-18	Connector, 18 Pin, 22-02-7183 Top EN	J119
5580-12782-00	Relay DPDT 12VDC	K1
5671-13732-00	LED, Display Red, T1 $\frac{1}{2}$	LED1-LED15, LED17
5190-10270-00	Transistor, 2N3906 PNP	Q1, Q2
5162-12635-00	Transistor, Tip 102	Q3, Q4, Q7, Q8, Q11, Q12, Q15, Q16, Q19, Q20, Q23, Q24, Q27, Q28, Q31, Q32
5192-12428-00	Transistor, Tip 107	Q5, Q6, Q9, Q10, Q13, Q14, Q17, Q18, Q21, Q22, Q25, Q26, Q29, Q30, Q33, Q34
5220-15710-00	Transistor-FET, STP20N10L, N-Channel	Q35-Q70
5160-10269-00	Transistor, 2N3904, NPN	Q71
5019-09669-00	SIP Resistor, 1K $\Omega$ , 9R 10, 5%	RP14
5019-16328-00	SIP Resistor, 2.2K $\Omega$ , 9R 10P, 5%	RP19
5019-10661-00	SIP Resistor, 10K $\Omega$ , 9R 10, 5%	RP1-RP13, RP15-RP18, RP20-RP23
5010-13517-00	Resistor, 15 $\Omega$ , 1/4W,	R247
5010-13594-00	Resistor, 1k $\Omega$ , 1/8W, 5% Film	R1, R22, R23, R31-R34, R51, R52, R61, R62, R71, R72, R81, R82, R99, R100, R109, R110, R119, R120, R121, R124, R191, R193, R194, R197, R201, R204, R205-R215, R217-R244
5010-13365-00	Resistor, 4.7k $\Omega$ , 1/8W, 5%	R2
5010-13366-00	Resistor, 470 $\Omega$ , 1/8W, 5%	R3, R4, R7, R8, R9, R136-R171
5010-13368-00	Resistor, 3.9k $\Omega$ , 1/8W, 5%	R5
5010-09160-00	Resistor, 220 $\Omega$ , 1/4W, 5%	R6, R11, R172, R190, R195, R196, R198, R200
5010-14395-00	Resistor, 6.8k $\Omega$ , 1/8W, 5%	R10, R284, R289, R291
5010-13593-00	Resistor, 10k $\Omega$ , 1/8W, 5% Film	R12, R21, R25-R28, R29, R43-R50, R91-R98, R134, R135, R192, R199, R245, R248-R282
5010-13364-00	Resistor, 33 $\Omega$ , 1/8W, 5%	R13-R20, R24, R30, R133, R174, R216
5010-09358-00	Resistor, 1k $\Omega$ , 1/4W, 5%	R35, R36, R53, R54, R65, R68, R75, R78, R85, R88, R103, R106, R115, R116, R127, R128
5010-13372-00	Resistor, 220 $\Omega$ , 1/8W, 5%	R37, R39, R55, R57, R63, R66, R73, R76, R83, R86, R101, R104, R111, R113, R122, R125, R283
5010-12427-00	Resistor, 22 $\Omega$ , 1W, 5%	R38, R40, R56, R58, R64, R67, R74, R77, R84, R87, R102, R105, R112, R114, R123, R126
5010-08992-00	Resistor, 560 $\Omega$ , 1/4W, 5%	R41, R42, R59, R60, R69, R70, R79, R80, R89, R90, R107, R108, R117, R118, R131, R132
5010-14093-00	Resistor, 0 $\Omega$ , 1/8W, 5%	R246
5010-09999-00	Resistor, 2K $\Omega$ , 1/4W, 5%	R175, R180, R186-R189
5010-14711-00	Resistor, 10k $\Omega$ , 1W, 5%	R176-R179, R181-R185
5010-13595-00	Resistor, 2.7k $\Omega$ , 1/8W, 5% Film	R202
5010-13843-00	Resistor, 22k $\Omega$ , 1/8W, 5% Film	R203
5010-13841-00	Resistor, 47k $\Omega$ , 1/8W, 5%	R285-R290, R292-R295
5011-13292-00	Resistor, 330 $\Omega$ , 2W, 5%	R296-R298
5645-12554-00	Switch DIP, 4 Position	S1
5824-09248-00	Test Point #1502-1	TP5, TP6
5431-10449-00	IC, 555 Timer	U1
5315-12812-00	IC, 74HCT138, 3 to 8 Decoder	U2, U4, U5, U6
5315-12813-00	IC, 74HCT245, Octal Transceiver	U3
5315-13079-00	IC, 74HCT574, Octal D-Latch	U7, U26, U28-U32, U34, U44
5281-09487-00	IC, 74LS74, Dual D F/F	U8-U10, U13-U16, U19, U20
5370-12272-00	IC, LM339, Quad Comp	U11, U12, U17, U18, U25, U37, U39, U40, U42, U43, U48, U49, U50, U51, U55, U56, U57
5315-12821-00	IC, 74HCT240, Octal Buffer	U21-U23, U38, U41, U46, U47, U52-U54
5162-12422-00	Trans, ULN 2803 Oc-Drl	U24, U27, U33, U35, U45
5250-09157-00	Reg, 7805, 1.0A, 5V	U36
5311-12538-00	IC, 74HC14, Hex S-T-	U58
5671-12993-00	LED, Green, 5mm, T1 $\frac{1}{2}$ Diffused	LED16
5070-09266-00	Diode, 1N5817, 1.0A, Schottky	D85, D86
DNP	Do Not Populate	TP1-TP4, TP7, RC1, CL1-CL8
MRD	Missing Reference Designators	R173, RP24-RP27, C126, R129, R130

04-12621

# 04-12621

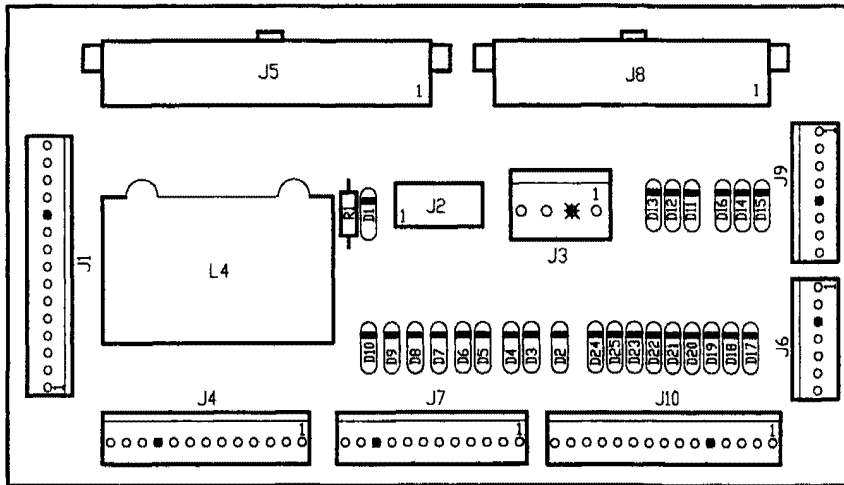
## P2000 Audio Amplifier PCB Assembly



<u>Designator</u>	<u>Part Number</u>	<u>Description</u>	<u>Designator</u>	<u>Part Number</u>	<u>Description</u>
R18	5020-14156-00	Resistor, 10K $\Omega$ , 1/10W 5% R0805	C5, C6, C11, C12	5052-15041-00	Capacitor, .22 $\mu$ f, 25V Y5V, 0805
R19, R29	5020-16081-00	Resistor, 18K $\Omega$ , 1/10W 5% 0805	C30, C32, C40		
R24, R36	5020-16082-00	Resistor, 68K $\Omega$ , 1/10W 5% 0805	C13, C27, C28,	5052-16078-00	Capacitor, .068 $\mu$ f, 25V $\pm$ 10%, 7R 0805
R14	5020-16080-00	Resistor, 82K $\Omega$ , 1/10W 5% 0805	C33, C34		
R1, R2, R4	5020-16079-00	Resistor, 56K $\Omega$ , 1/10W 5% 0805	C14, C35, C36	5040-14630-00	Capacitor, 2200 $\mu$ f, 25V Radial
R7			C29	5040-11036-00	Capacitor, 47 $\mu$ f, 16V Radial $\pm$ 20%, 105C
R13	5020-14383-00	Resistor, 9.1K $\Omega$ , 1/10W 1% SMD-0805	C26	5052-16221-00	Capacitor, 68 $\mu$ f, 16V Y5V +80% -20%, 0805
R10, R12, R20	5020-14349-00	Resistor, 0K $\Omega$ , 1/10W SMD-0805	D1	5671-16083-00	LED, Red Side View, SMT
R21, R26, R30			U4	5250-16069-00	IC, Regulator 78L05 SOIC8
R32			U5	5250-16070-00	IC, Regulator 78L08 SOIC8
R11, R15, R16	5020-16222-00	Resistor, 100K $\Omega$ , 1/10W 5% SMD-0805	U2	5370-16072-00	IC, LM324A Quad OpAmp SOIC14
R17			U3	5370-16073-00	IC, Audio Amp TDA7375
R3, R6	5020-15029-00	Resistor, 2.4K $\Omega$ , 1/10W 5% SMD-0805	U1	5371-16074-00	IC, DAC Stereo, 16Bit CS4333, SOP8
R25, R28, R31	5020-14157-00	Resistor, 1K $\Omega$ , 1/10W 5% SMD-0805	L2 - L7	5553-16075-00	Ferite BD, 60 $\Omega$ , 6A, 1806 SMD
R37, R38			J1	5791-16076-08	Connector, JST PH, Vertical 8-Pin Header, PCB Mount, R/A MiniFit 6-Pin
C1, C2, C7, C9	5051-14151-00	Capacitor, 10 $\mu$ f, 16V $\pm$ 20%, SMD TANT	J3	5791-16071-06	Connector, 4 CKT, Vertical Header 10A/250V
C3, C4, C15, C31	5052-14165-00	Capacitor, .1 $\mu$ f, 50V $\pm$ 20%, SMD Z5U	J2	5796-14955-00	Connector, 4 CKT, Vertical Header 10A/250V
C37			HS1	5705-16067-00	Heat Sink, Multiwatt 15, 2 Inch
C10, C8	5052-14166-00	Capacitor, 1000pf, 50V $\pm$ 5%, SMD			
C17	5052-14170-00	Capacitor, 6800pf, 50V $\pm$ 5%, SMD			
C20, C21, C22,	5052-14367-00	Capacitor, 150pf, 50V $\pm$ 5%			
C23, C24, C25					

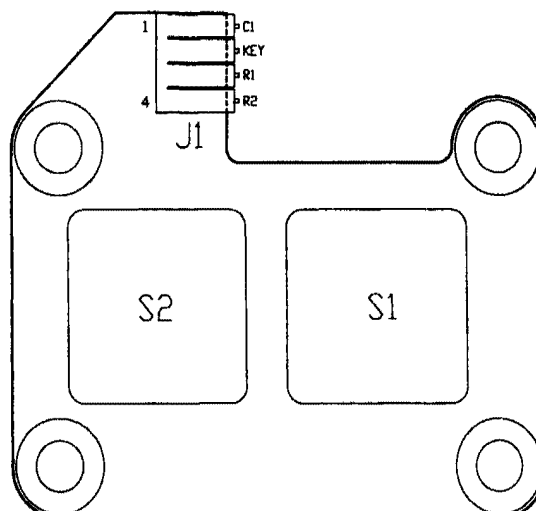


## 04-12492 Coin Door Interface PCB Assembly



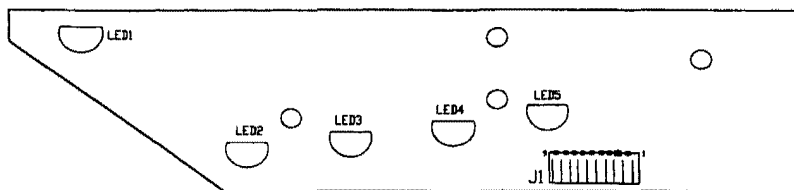
<u>Designator</u>	<u>Part Number</u>	<u>Description</u>
D1-D25	5070-09054-00	Diode, 1N4004, 1.0A
J5	5791-13356-24	Header, PCB Mount, 0.165 Center, 24 Pin
J8	5791-13356-20	Header, PCB Mount, 0.165 Center, 20 Pin
J9	5791-13830-08	8H, Straight Square Pin, .100 Solid Tab
J6	5791-13830-07	7H, Straight Square Pin, .100 Solid Tab
J1, J10	5791-13830-15	15H, Straight Square Pin, .100 Solid Tab
J7	5791-13830-12	12H, Straight Square Pin, .100 Solid Tab
J4	5791-13830-13	13H, Straight Square Pin, .100 Solid Tab
J3	5791-13830-04	4H, Straight Square Pin, .156
J2	5791-11000-10	10 Square Pin Straight Header, .100 w/Shroud
R1	5010-13517-00	Resistor, 15Ω, ¼W

## 04-12612 2 Switch Flipper PCB Assembly



<u>Designator</u>	<u>Part Number</u>	<u>Description</u>
J1	5791-12622-04	R/A Square Pin Header, .100 Solid Tab
S1, S2	5641-16194-00	Keyswitch w/Jumper

## A-18617-1 Trough IR LED PCB Assembly

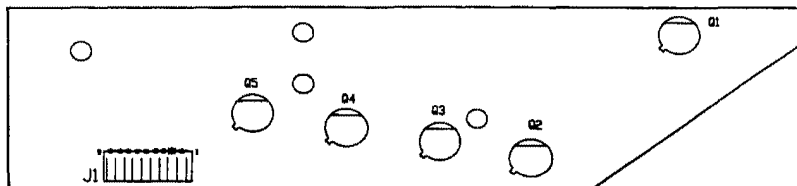


**Designator**  
LED1 – LED5  
J1

**Part Number**  
5671-12731-00  
5791-12622-09

**Description**  
Infra Red Diode  
Connector, 9-Pin Header Sq.

## A-18618-1 Trough IR Photo Transistor PCB Assembly



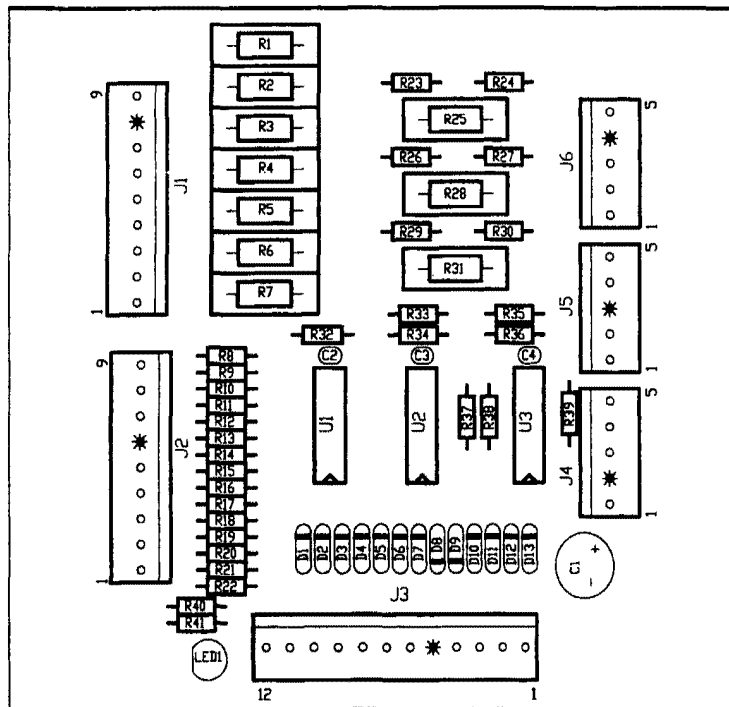
**Designator**  
Q1 – Q5  
J1

**Part Number**  
5163-14114-00  
5791-12622-09

**Description**  
Infra Red Photo Transistor  
Connector, 9-Pin Header Sq.

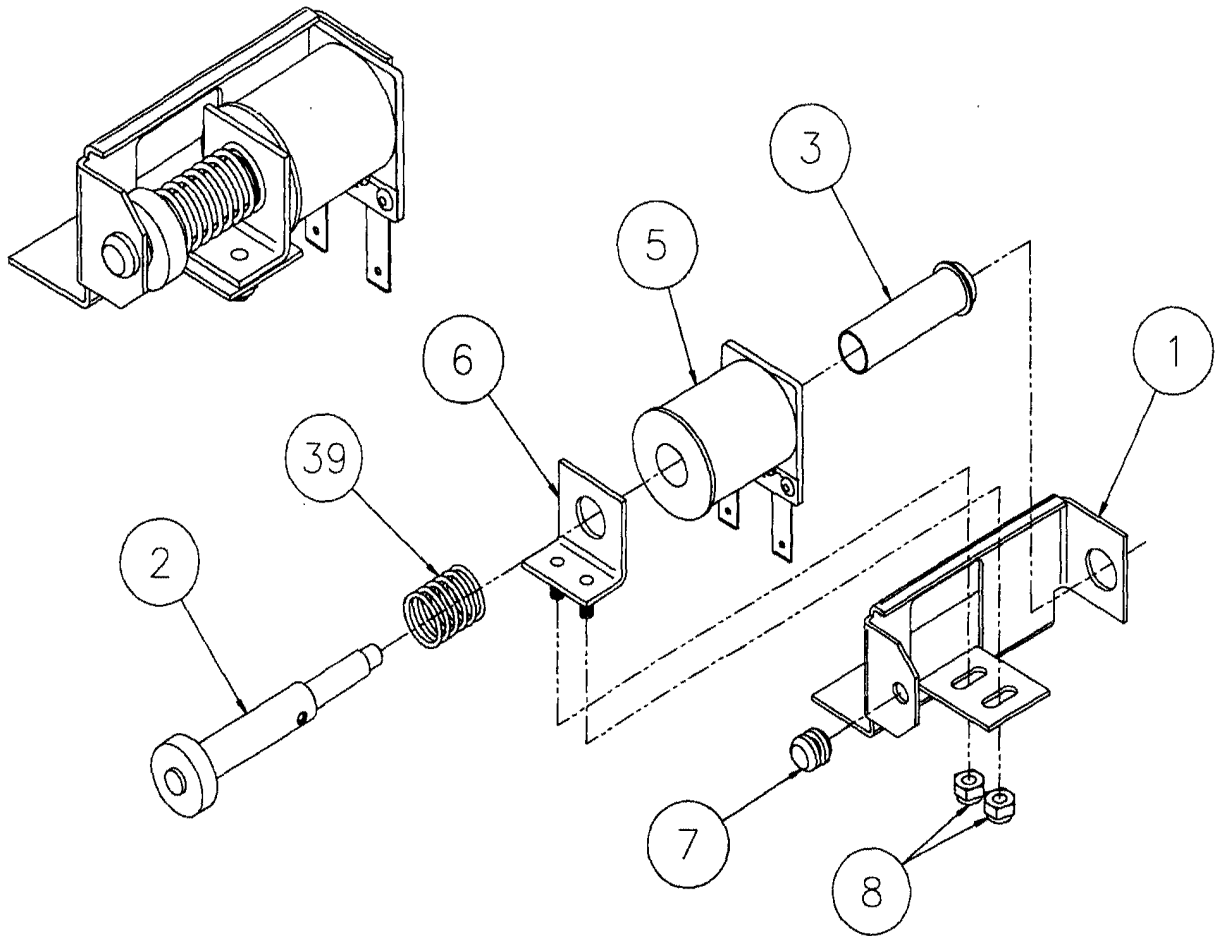
# A-20246

## 10-Opto PCB Assembly w/Bracket



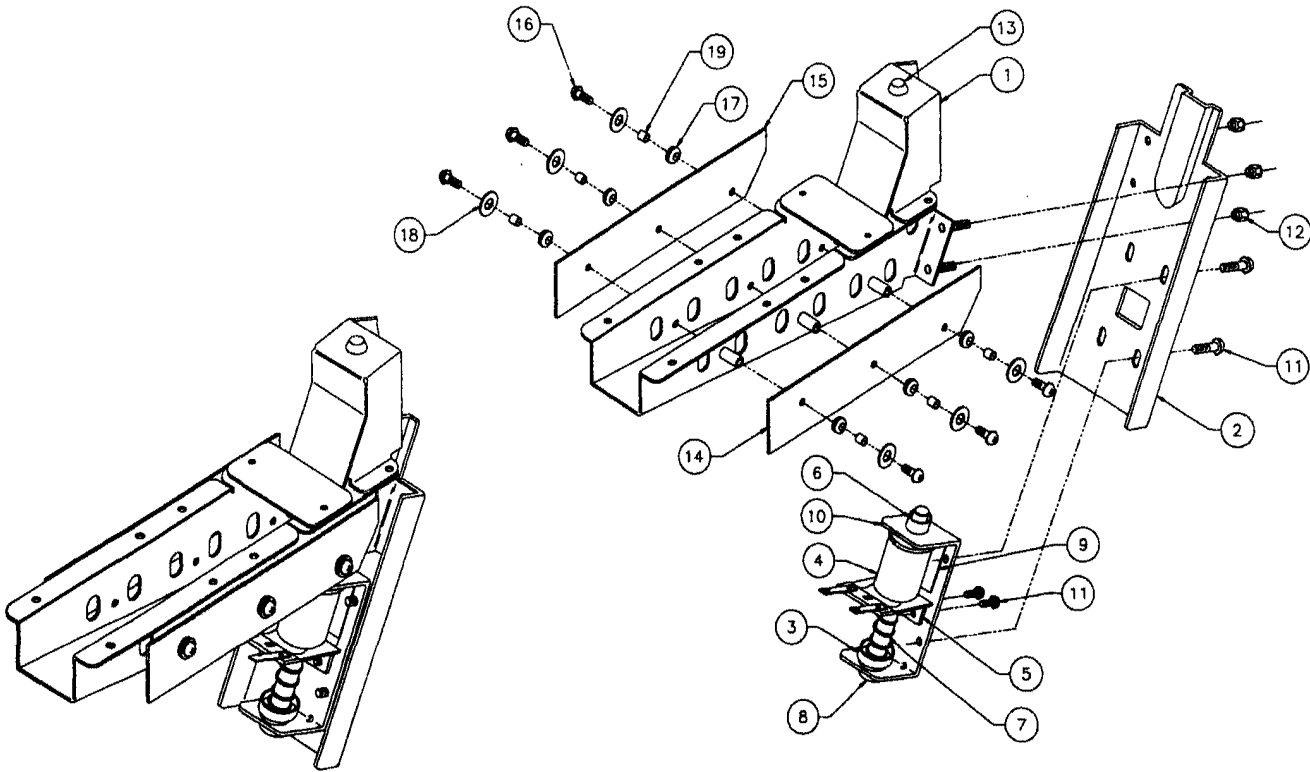
<u>Designator</u>	<u>Part Number</u>	<u>Description</u>
	<b>A-18159.1</b>	10-Opto PCB Assembly
C1	5040-10974-00	Capacitor, 100M, 35V radial
C2-C4	5043-08996-00	Capacitor, 0.1M, 50V ±20% Ax.
D1-D13	5070-09054-00	Diode 1N4004, 1.0A
J1, J2	5791-10862-09	Connector, 9-Pin Header
J3	5791-10862-12	Connector, 12-Pin Header
J4- J6	5791-10862-05	Connector, 5-Pin Header
LED1	5671-13732-00	LED, Display Red T-1 ¼
R1-R7, R28, R31, R50	5010-12928-00	Resistor, 270Ω, 2W, 5%
R8-R24, R26, R27, R29, R30	5010-09999-00	Resistor, 2KΩ, ¼W, 5%
R32, R35, R39-R41	5010-09162-00	Resistor, 100KΩ, ¼W, 5%
R34, R36-R38,	5010-08774-00	Resistor, 22KΩ, ¼W, 5%
R33	5010-08776-00	Resistor, 68KΩ, ¼W, 5%
U1-U3	5370-12272-00	IC, LM339 Quad Comp
-	01-10756	PCB Mounting Bracket
-	07-6688-18N	Rivet, 1/8" x 3/16"

# A-22429-4 Auto-Fire Assembly



<u>Item</u>	<u>Part Number</u>	<u>Description</u>
1	01-14618.1	Auto-Fire Bracket
2	A-6306-2	Plunger
3	03-7067	Coil Tubing
4	04-10910-1	Coil Centering Bracket
5	AE1-23-800	Coil Assembly
6	10-135	Spring
7	23-6420	Rubber Grommet
8	4408-01119-01	Nut 8-32 ESN/NTM

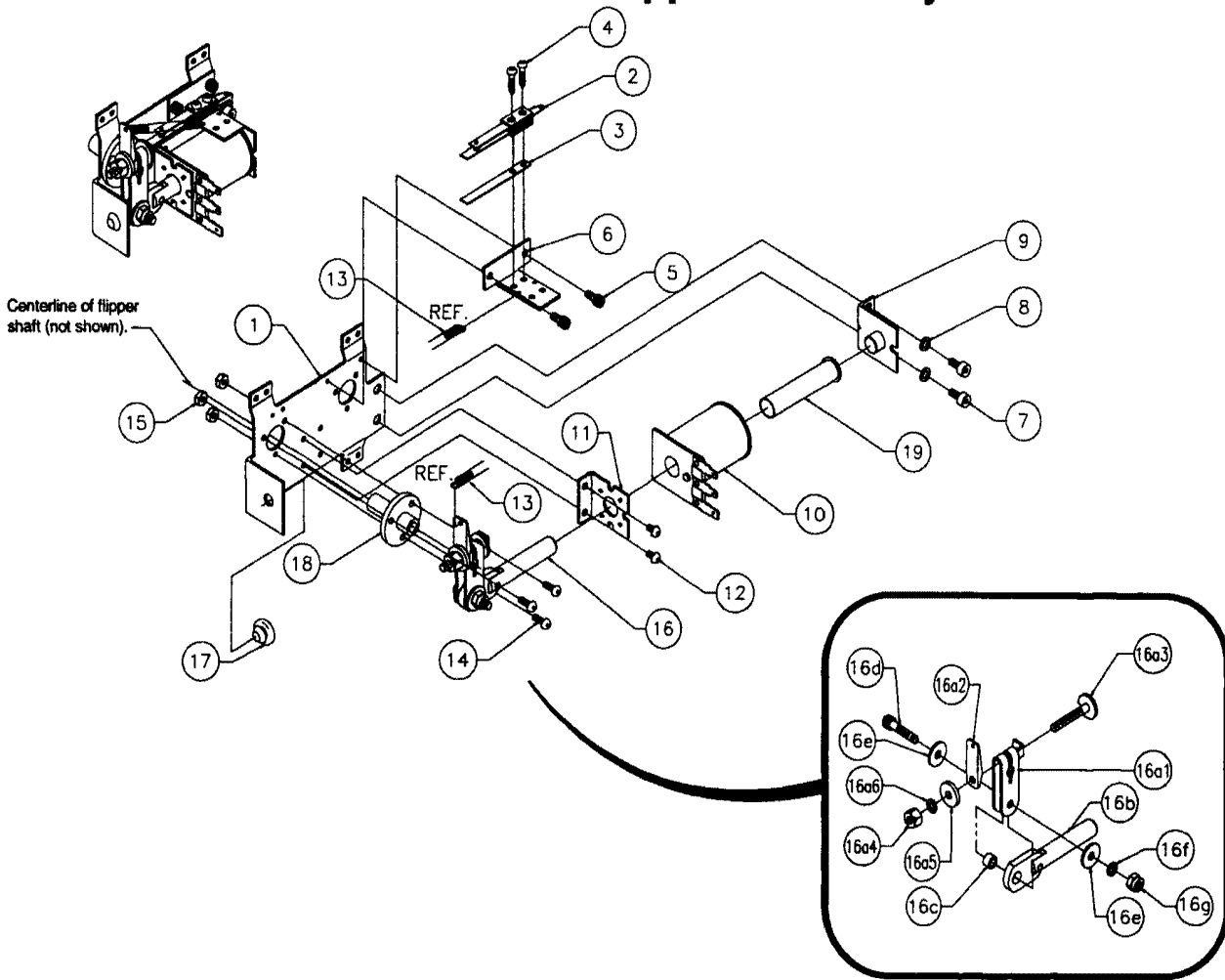
# A-19963-4 Ball Trough Assembly



<u>Item</u>	<u>Part Number</u>	<u>Description</u>
1	A-16809-2	Ball Trough Welded Assembly
2	01-11587	Ball Trough Front
3	A-6306-2	Bell Armature Assembly
4	AE1-26-1500	Coil
5	01-8-508-T	Coil Retainer Bracket
6	03-7067-5	Coil Tubing
7	10-135	Spring
8	23-6420	Rubber Grommet
9	03-8523	Insulator
10	01-11586	Coil Mounting Bracket
11	4008-01227-05	MS 8-32 x 5/16" Pin-Hd-S

<u>Item</u>	<u>Part Number</u>	<u>Description</u>
12	4408-01119-00	Nut 8-32 ESN
13	23-6702	Bumper Plug
14	A-18617-1	Trough IRED LED PCB Assembly
15	A-18618-1	Trough IRED Transistor PCB Assembly
16	4006-01003-10	MS 6-32 x 5/8" P-PH-S
17	23-6626	Rubber Grommet
18	4700-00004-00	FW .146 x .375 x .032
19	02-4975	Bushing

# A-23004-R-2 Flipper Assembly

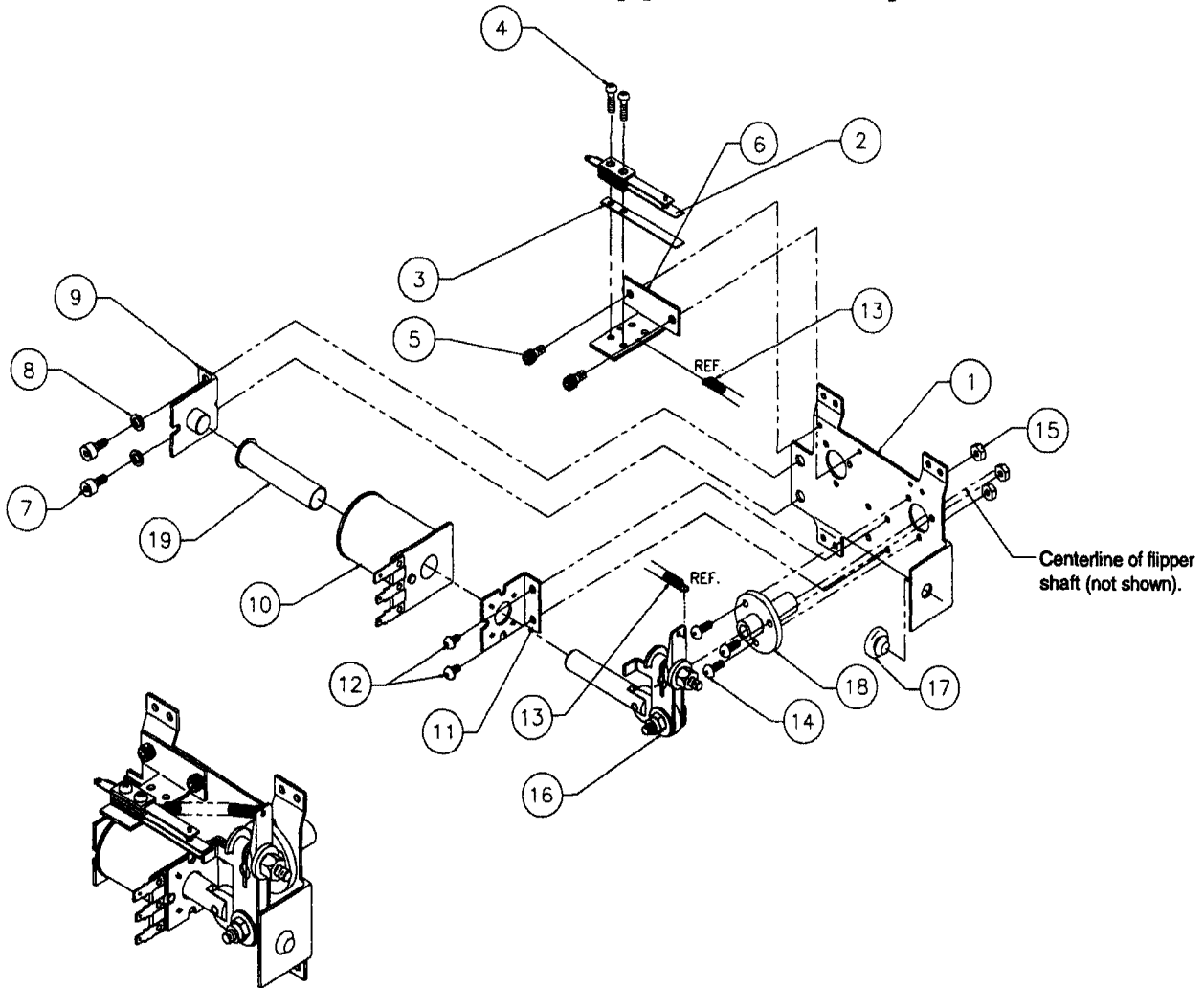


Item	Part Number	Description	Item	Part Number	Description
1	A-14877.1-R	Flipper Bracket Assembly, Right	16a)2.	01-9376	Bracket Retaining Spring
2	SW-1A-194	Switch Assembly	16a)3.	04-11222	Locking Stud
3	03-9878	Shock Deflector	16a)4.	4410-01127-00	Nut 10-32 Hex Heavy Duty
4	4006-01003-08	MS 6-32 x 1/2" P-PH-S	16a)5.	4700-00107-00	FW .203 x .625 x .104
5	4008-01227-05	MS 8-32 x 5/16" Pin Hd-SEMS	16a)6.	4701-00004-00	LW #10 Split
6	01-14998	Switch Bracket	16b)	A-15847	Flipper Link Assembly
7	4010-01066-06	CS-10-31 x 3/8" SH	16c)	02-4676	Bushing - Link Spacer
8	4701-00004-00	LW #10 Split	16d)	4010-01086-14	CS 10-32 x 7/8" SH
9	A-12390	Flipper Stop Bracket Assembly	16e)	4700-00023-00	FW .203 x .625 x .059
10	FL1-11629	Flipper Coil (Blue)	16f)	4701-00004-00	LW #10 Split
11	01-7695-1	Solenoid Bracket	16g)	4410-01132-00	Nut 10-32 ESNA
12	4006-01003-04	MS 6-32 x 1/4" P-PH-S	17	23-6577	Bumper Plug
13	10-364	Spring	18	03-7568	Flipper Bushing
14	4006-01005-06	MS 6-32 x 3/8" P-PH	19	03-7066-5	Coil Tubing
15	4406-01117-00	Nut 6-32 Hex	<b>Associated Parts: (Not Shown)</b>		
16	A-23000	Flipper Crank Link Assembly		23-6695	Flipper Ring
16a)	A-22999	Flipper Crank Assembly		20-10110-5	Flipper Bat w/Shaft
16a)1.	01-11764-R	Flipper Crank, Right			

## Notes...

- Each Flipper Assembly is mounted beneath the playfield, in conjunction with the Plastic Flipper & Shaft, and Flipper Rubber on the upper side of the playfield.
- With the flipper, in the non-activated position, the E.O.S. Switch contacts must have a gap of .062 (±.015) inch. When flipper is activated switch must close.
- Any adjustment of the E.O.S. switch must be made at a minimum distance of 0.25 inch from the switch body.
- Longer blade of E.O.S. switch must be made straight. Gap adjustment is done by adjusting shorter blade.
- All moving elements of the assembly must operate freely without any evidence of binding.
- Apply Loctite™ 245 when reattaching screws to the Flipper Stop Assembly, the Solenoid Bracket, and the Flipper Bushing.

# A-23001-L-2 Flipper Assembly



Item	Part Number	Description
1	B-13104.1-L	Flipper Bracket Assembly, Right
2	SW-1A-194	Switch Assembly
3	03-9878	Shock Deflector
4	4006-01003-08	MS 6-32 x 1/2" P-PH-S
5	4008-01227-05	MS 8-32 x 5/16" Pin Hd-SEMS
6	01-14998	Switch Bracket
7	4010-01066-06	CS-10-31 x 3/8" SH
8	4701-00004-00	LW #10 Split
9	A-12390	Flipper Stop Bracket Assembly
10	FL1-11629	Flipper Coil (Blue)
11	01-7695-1	Solenoid Bracket
12	4006-01003-04	MS 6-32 x 1/4" P-PH-S
13	10-364	Spring
14	4006-01005-06	MS 6-32 x 3/8" P-PH
15	4406-01117-00	Nut 6-32 Hex
*16	A-23000	Flipper Crank Link Assembly
16a)	A-22999	Flipper Crank Assembly
16a)1.	01-11764-R	Flipper Crank, Right

Item	Part Number	Description
16a)2.	01-9376	Bracket Retaining Spring
16a)3.	04-11222	Locking Stud
16a)4.	4410-01127-00	Nut 10-32 Hex Heavy Duty
16a)5.	4700-00107-00	FW .203 x .625 x .104
16a)6.	4701-00004-00	LW #10 Split
16b)	A-15847	Flipper Link Assembly
16c)	02-4676	Bushing - Link Spacer
16d)	4010-01086-14	CS 10-32 x 7/8" SH
16e)	4700-00023-00	FW .203 x .625 x .059
16f)	4701-00004-00	LW #10 Split
16g)	4410-01132-00	Nut 10-32 ESNA
17	23-6577	Bumper Plug
18	03-7568	Flipper Bushing
19	03-7066-5	Coil Tubing

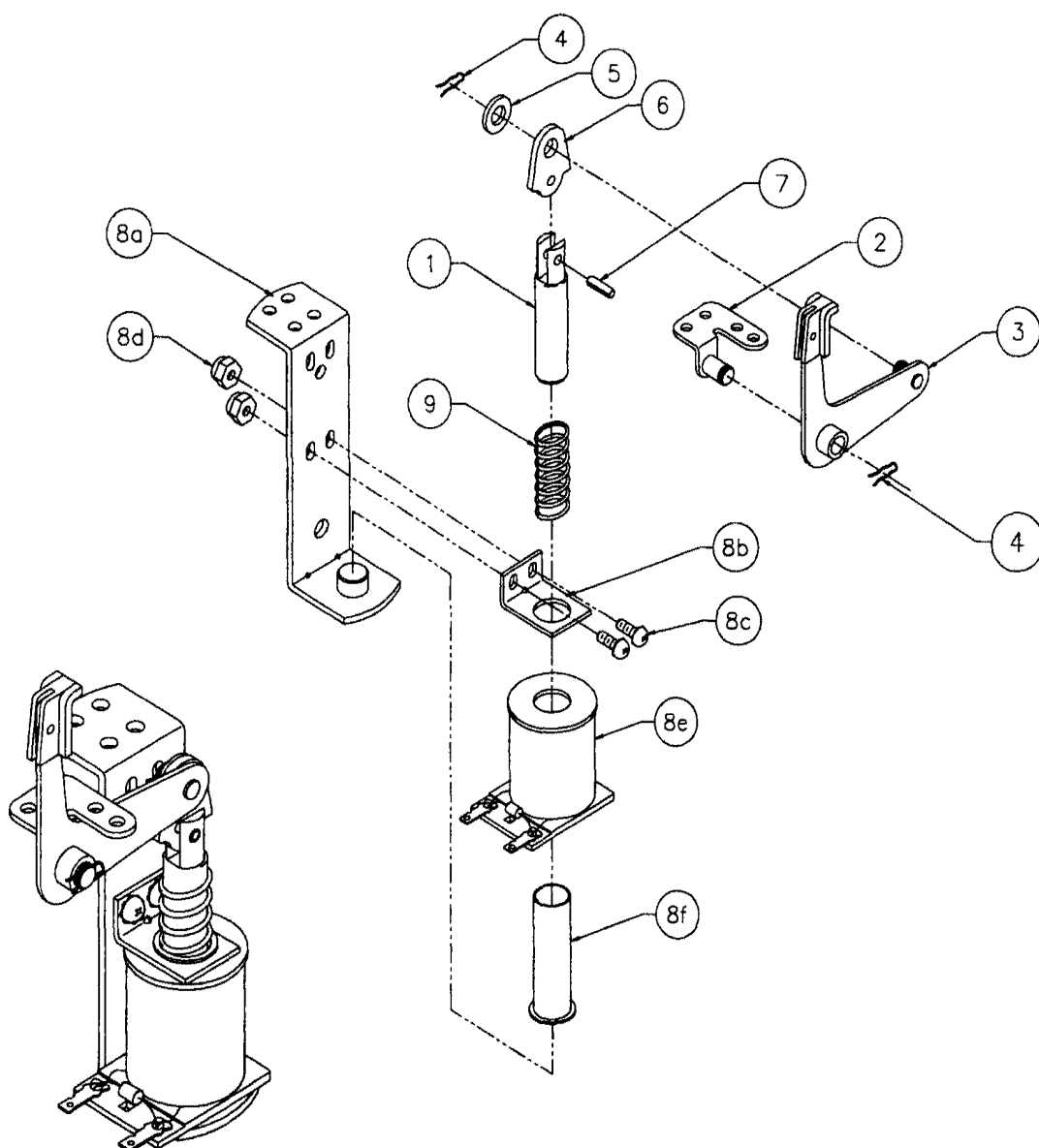
### Associated Parts: (Not Shown)

Part Number	Description
23-6695	Flipper Ring
20-10110-5	Flipper Bat w/Shaft

\*See A-23004-R, Flipper Assembly, for assembly detail drawing.

**Note: Switch Assembly to be attached to the Switch Bracket using the outermost threaded holes on the bracket**

## A-17811 Kicker Assembly

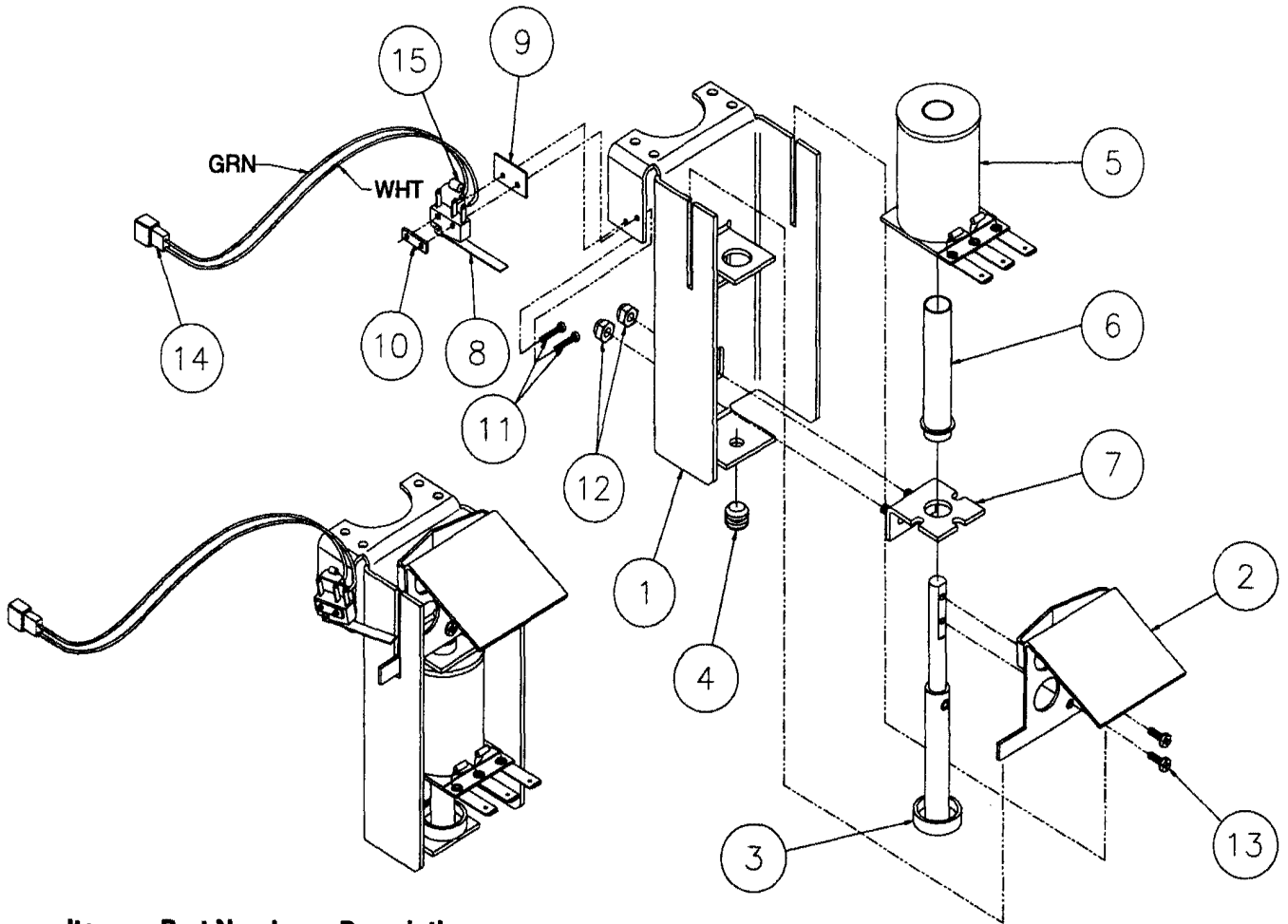


<u>Item</u>	<u>Part number</u>	<u>Description</u>
1	02-2364	Coil Plunger
2	A-17810	Kicker Mounting Bracket Assembly
3	A-12664	Crank Assembly
4	12-6227	Hair Pin Clip
5	4700-00030-00	FW .265 x .500 x .067
6	03-8085	Armature Link
7	20-8716-5	Roll Pin 1/8" x 7/16"

<u>Associated Parts:</u>		
<u>Item</u>	<u>Part number</u>	<u>Description</u>
8	A-22207-6	Coil & Bracket Assembly-Left
8a)	A-17808	Bracket & Stop Assembly
8b)	01-8-508-S	Coil Retainer Bracket
8c)	4006-01017-06	MS 6-32 x 3/8" P-RH-S
8d)	4406-01119-00	Nut 6-32 ESN
8e)	AE1-26-1200	Coil Assembly
8f)	03-7066	Coil Tubing
9	10-128	Kicker Spring



## A-22989 Skip Ramp Assembly

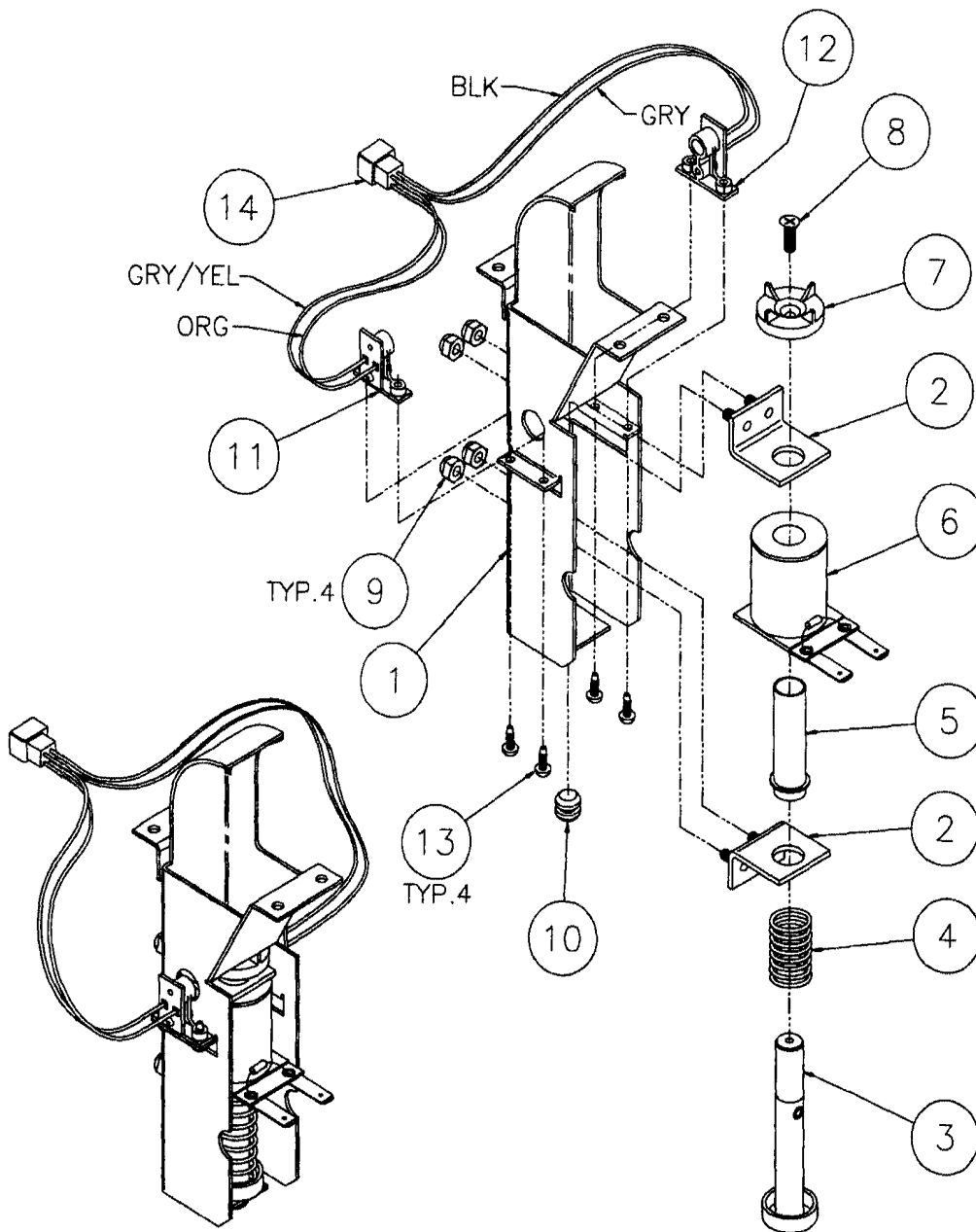


<u>Item</u>	<u>Part Number</u>	<u>Description</u>
1	01-15142	Main Bracket
2	04-12615	Ramp Bracket
3	04-12616.2	Skip Ramp Armature Assembly
4	23-6420	Grommet
5	FL1-11753	Flipper Coil – Yellow
6	03-7067-6	Coil Tubing
7	04-10911-1	Coil Centering Bracket
8	5647-12693-07	Sub-Mini Micro Switch
9	01-8600	Insulator
10	01-8240	Plate Nut 2-56
11	4002-01105-08	MS 2-56 x ½ P-PH-S
12	4408-01119-01	Nut 8-32 ESNA/NTM
13	4008-01227-06	MS 8-32 x 3/8 Pin Hd SEMS
14	H-23019-2	2 – Pin Cable
15	5070-09054-00	Diode – 1N4004 1.0A

### Associated Parts: (Not Shown)

<u>Part Number</u>	<u>Description</u>
A-22988	Skip Ramp Flap Assembly
01-15140	Flap Assembly Mounting Bracket

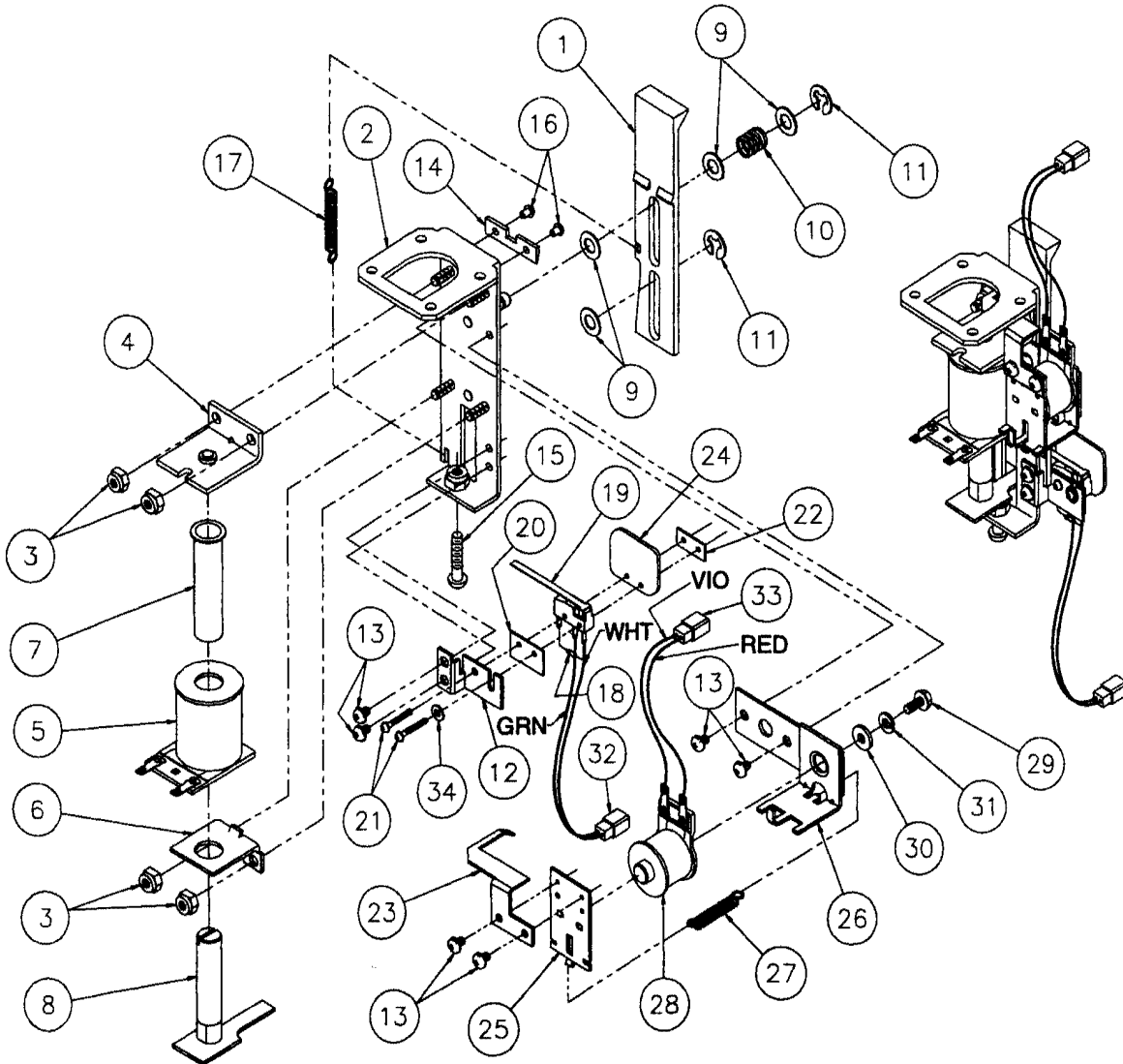
## A-23156 Popper Assembly



<u>Item</u>	<u>Part Number</u>	<u>Description</u>
1	04-12741	Popper Bracket
2	04-10322-2	Coil Bracket
3	04-10291	Armature & Extension Assembly
4	10-135	Plunger Spring
5	03-7067	Coil Tubing
6	AE1-25-1000	Coil Assembly
7	03-8561	Ball Popper Cup
8	4106-01152-08	SMS 6-32 x 1/2 TFP - FLH
9	4408-01119-01	Nut 8-32 ESNA - NTM
10	23-6420	Grommet
11	A-16909	Opto P/T Assembly
12	A-16908	Opto LED Assembly
13	4106-01013-06	SMS 6-32 x 3/8 P- PH T-25
14	H-23022-4	4-Pin Cable

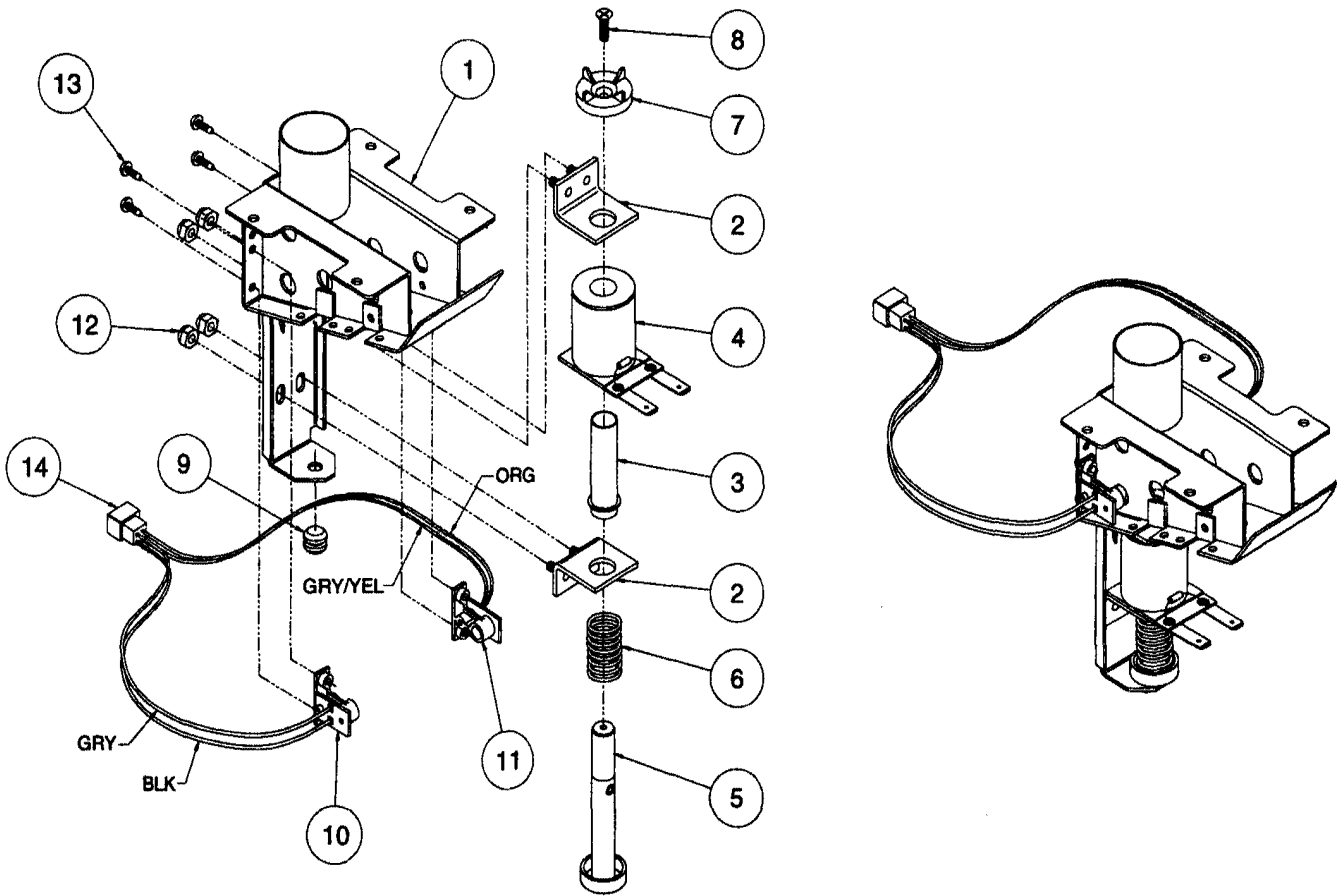
# A-15211-1

## 1 Bank Drop Target Assembly



Item	Part Number	Description	Item	Part Number	Description
1	03-8750	Flush Target	18	5070-09054-00	Diode 1N4004 1.0A
2	A-14617	Bracket & Post Assembly	19	5647-12693-31	Sub Mini Micro Switch
3	4408-01119-01	Nut 8-32 ESNA-NTM	20	01-8600	Insulator
4	A-11397	Drop Target Stop Bracket	21	4002-01105-10	MS 2-56 x 5/8" P-PH-S
5	AE1-26-1200	Coil Assembly	22	01-8240	Plate Nut 2-56
6	01-8413	Coil Mounting Bracket	23	01-8647-R	Actuator
7	03-7066-4	Coil Tubing	24	03-8630	Actuator Guide
8	A-11388-2	Plunger & Reset Plate Assembly	25	A-15821	Armature Assembly
9	4700-00072-00	FW .256 x .500 x .032	26	A-15209	Frame & Eyelet Assembly
10	10-392	Compression Spring	27	10-363	Extension Spring
11	20-8712-25	E Ring - 1/4" Shaft	28	SM1-26-600	Coil Assembly
12	01-10183	Switch Bracket	29	4008-01021-06	MS 8-32 x 3/8" P-RH Brass
13	4006-01003-03	MS 6-32 x 3/16" P-PH-S	30	4700-00089-00	FW .172 x .437 x .062 Brass
14	03-8034	Single Target Stop	31	4701-00003-00	LW #8 Split
15	4010-01025-14	MS 10-32 x 7/8" P-RH	32	H-23019-2	Switch 2 Pin Cable
16	07-6688-17N	Rivet 5/32" x 1/8" Nickel	33	H-19523	Solenoid 2 Pin Cable
17	10-433	Extension Spring	34	4700-00003-00	FW .125 x .281 x .032

## A-20680-1 3 Ball Popper Assembly

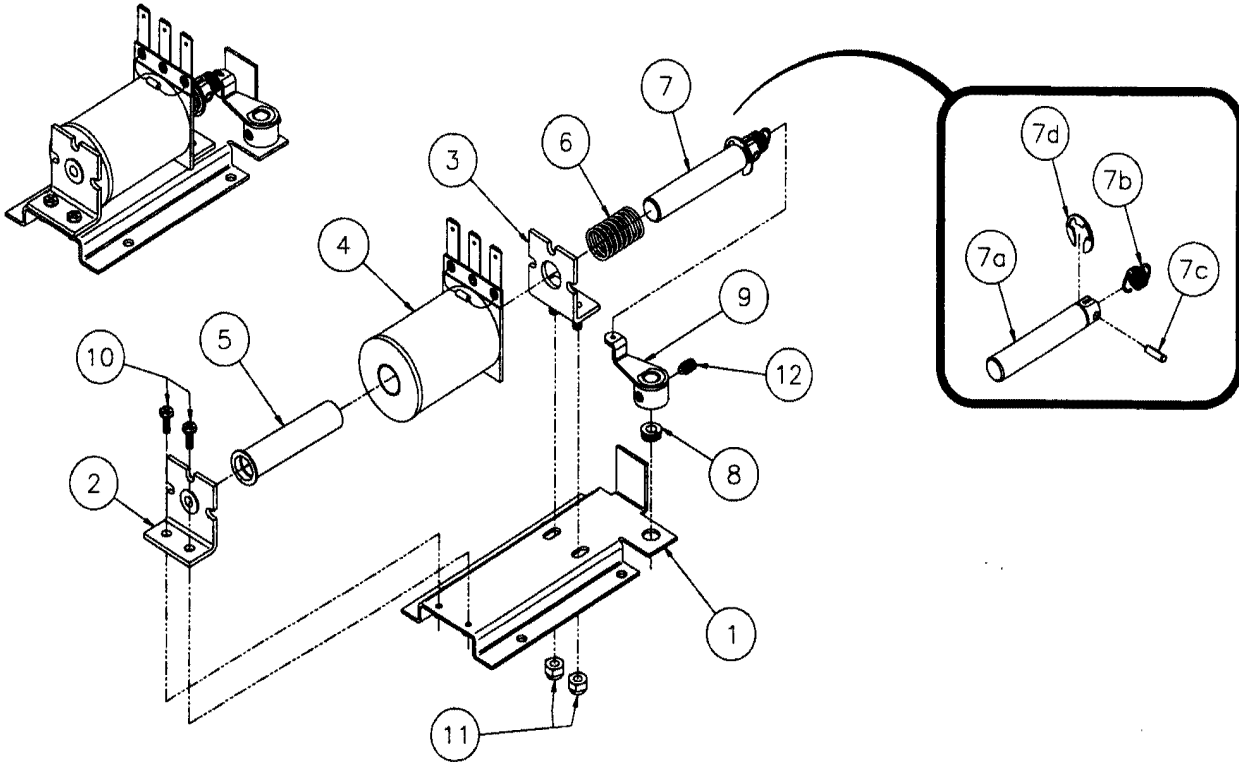


<u>Item</u>	<u>Part Number</u>	<u>Description</u>
1	04-10323	3 Ball Popper Frame
2	04-10322-2	Coil Bracket
3	03-7067	Coil Tubing
4	AE1-23-800	Coil Assembly
5	04-10291	Armature & Extension Assembly
6	10-135	Plunger Spring
7	03-8561	Ball Popper Cup
8	4106-01152-08	SMS 6-32 x 1/2" TFP-FLH
9	23-6420	Grommet
10	A-16908	OPTO LED Assembly
11	A-16909	OPTO P/T Assembly
12	4408-01119-01	Nut 8-32 ESNA/NTM
13	4106-01013-06	SMS 6-32 x 3/8 P-PH T-25
14	H-23022-5	4-Pin Cable

**Associated Parts:** (Not Shown)

<u>Part Number</u>	<u>Description</u>
04-12598	Popper Hood

# A-22993 Diverter Mechanism Assembly

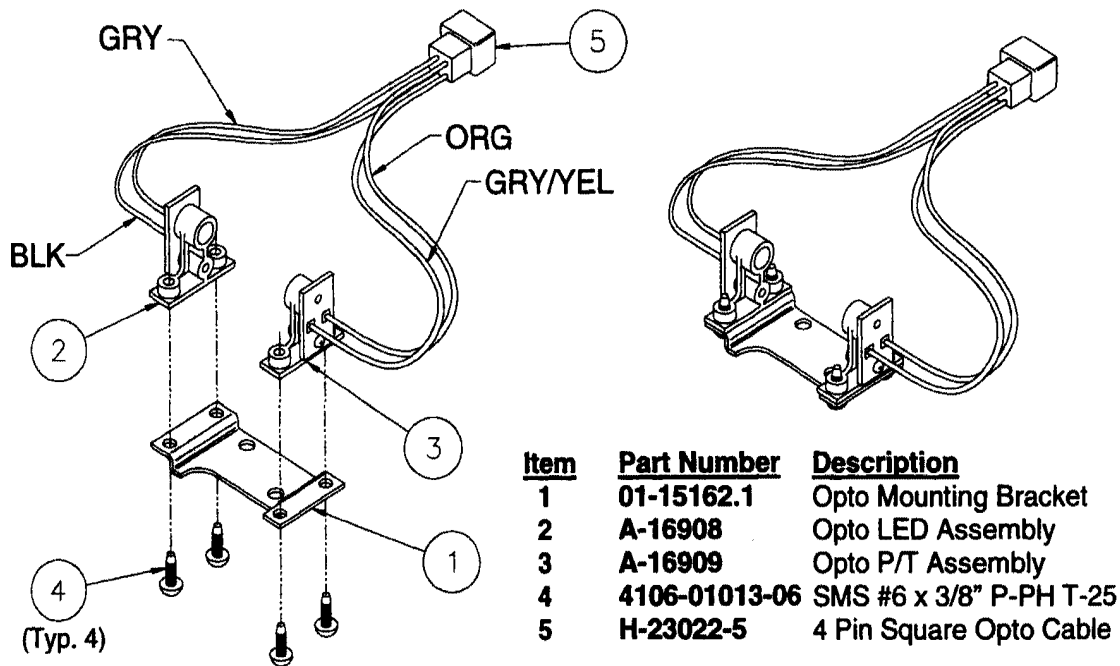


<u>Item</u>	<u>Part Number</u>	<u>Description</u>
1	04-12619	Diverter Mech Bracket
2	04-10911-6	3/4 Coil Centering Bracket
3	04-10911-1	3/4 Coil Centering Bracket
4	FL1-22241	Flipper Coil
5	03-7066-5	Coil Tubing
6	10-303	Master Spring
7	A-16636	Diverter Plunger Assembly
7a	02-4793	Diverter Plunger
7b	10-389	Gate Spring
7c	20-8716-5	Roll Pin, Ø1/8" x 7/16"
7d	20-8712-43	E-ring, Ø7/16" Shaft
8	20-8790	Nyliner Bearing
9	04-10408	Drive Arm Assembly
10	4008-01227-06	MS 8-32 x 3/8 PIN HD - S
11	4408-01119-01	Nut 8-32 ESNA - NTM
12	4010-01196-04	SS 10-32 x 1/4 SH - CP - N

**Associated Parts:** (Not Shown)

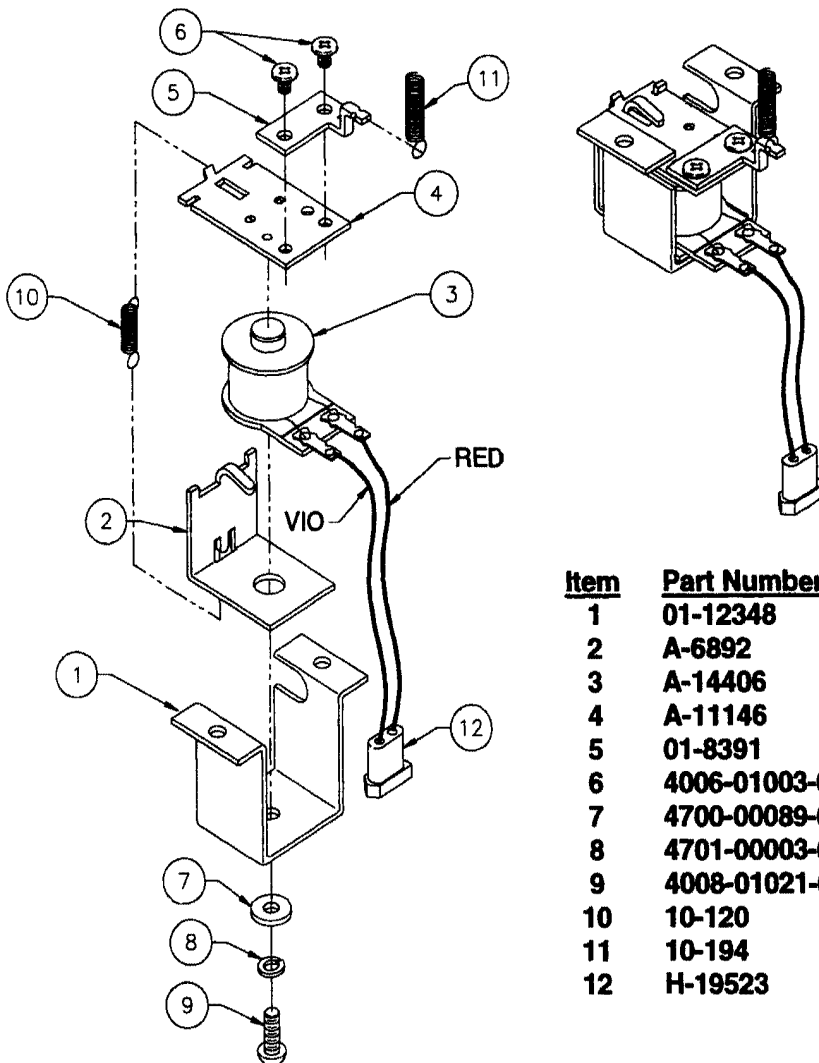
<u>Part Number</u>	<u>Description</u>
A-22970	Diverter Paddle Assembly

## A-23012 Opto Bracket Assembly



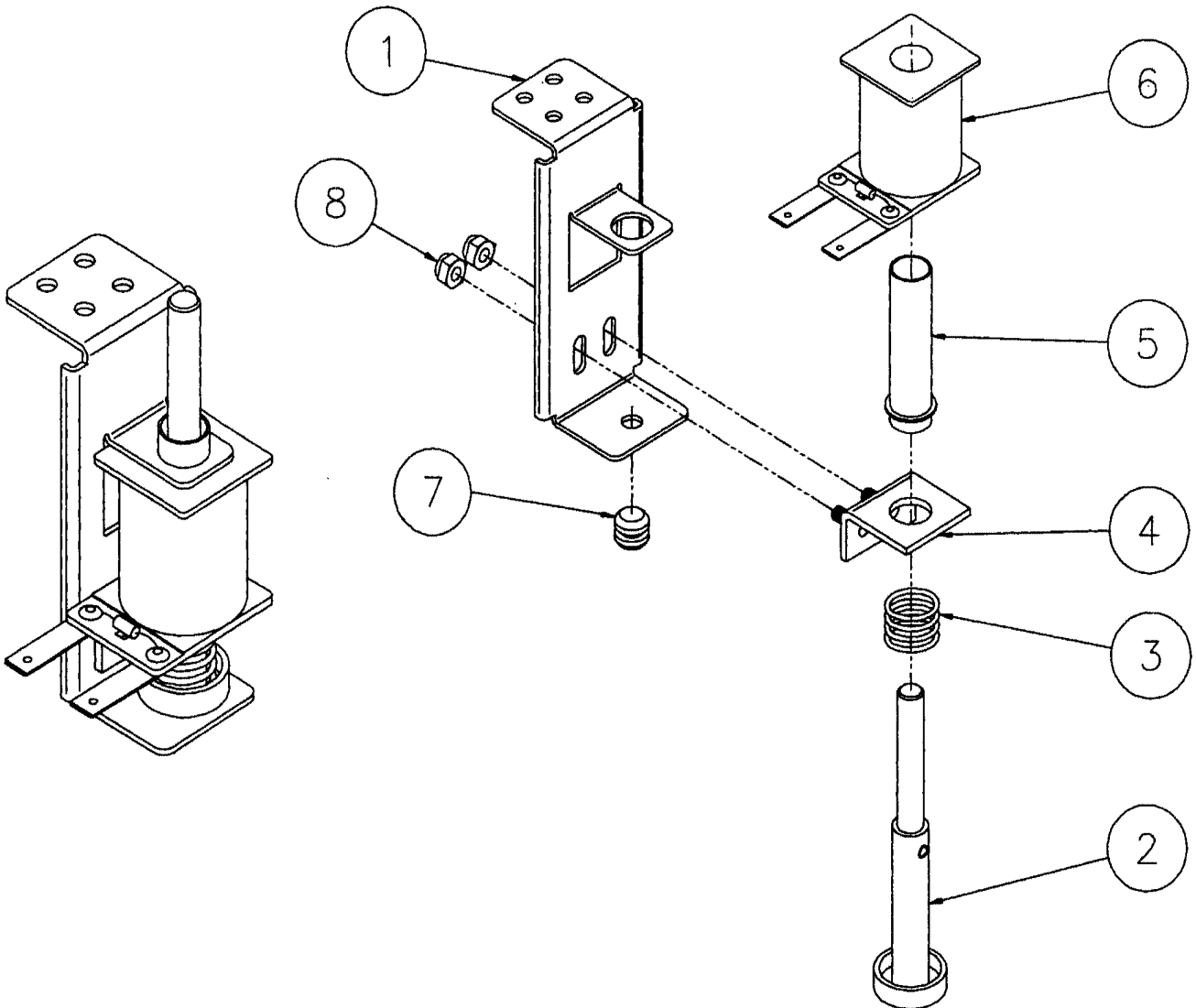
<u>Item</u>	<u>Part Number</u>	<u>Description</u>
1	01-15162.1	Opto Mounting Bracket
2	A-16908	Opto LED Assembly
3	A-16909	Opto P/T Assembly
4	4106-01013-06	SMS #6 x 3/8" P-PH T-25
5	H-23022-5	4 Pin Square Opto Cable

## A-17796 Ball Gate Actuator Assembly



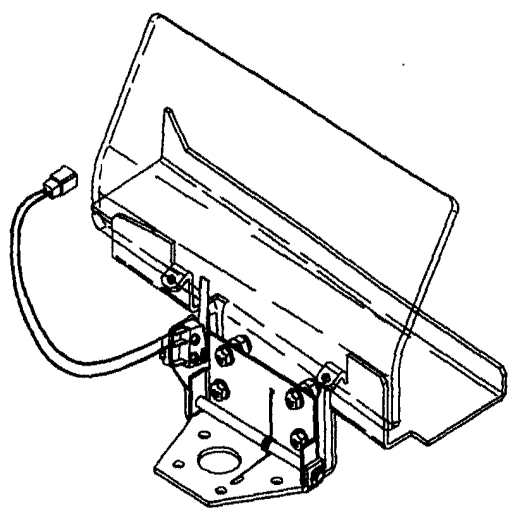
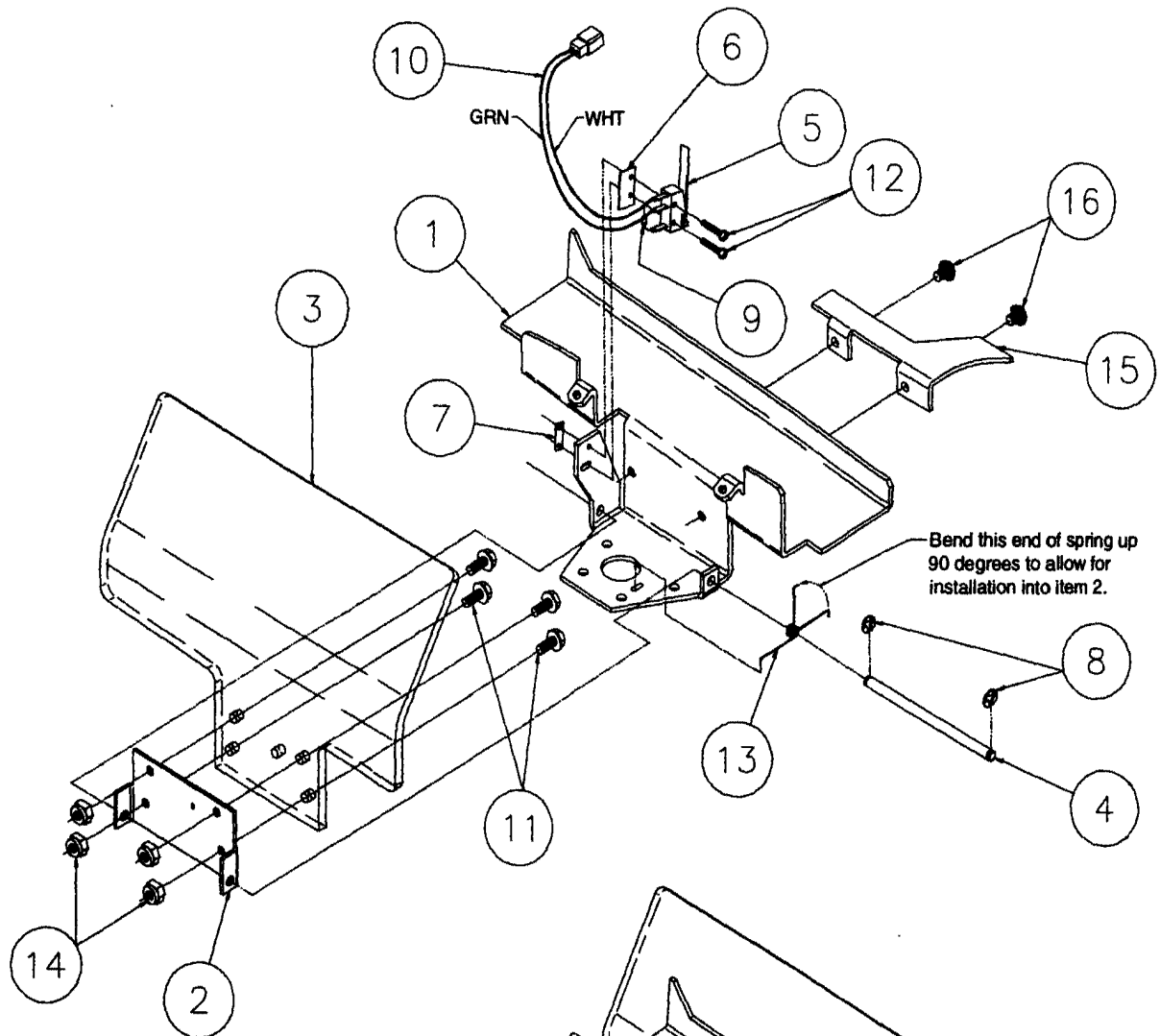
<u>Item</u>	<u>Part Number</u>	<u>Description</u>
1	01-12348	Ball Gate Coil Bracket
2	A-6892	Frame & Eyelet
3	A-14406	Coil Assembly
4	A-11146	Ball Gate Armature Assembly
5	01-8391	Armature Tip
6	4006-01003-03	MS 6-32 x 3/16" P-PH-S
7	4700-00089-00	FW .172 x 7/16 x .062 Brass
8	4701-00003-00	LW #8 Split
9	4008-01021-07	MS 8-32 x 7/16" P-RH-Brass
10	10-120	Spring
11	10-194	Extension Spring
12	H-19523	2 Pin Cable

## A-22977 Up/Down Post Assembly



<u>Item</u>	<u>Part Number</u>	<u>Description</u>
1	01-15122	Up/Down Post Assembly Bracket
2	A-17986	Bell Armature Assembly
3	10-135	Plunger Spring
4	04-10910-1	Coil Centering Bracket
5	03-7067-5	Coil Tubing
6	AE1-26-1500	Coil
7	23-6420	Grommet
8	4408-01119-01	Nut 8-32 ESN/NTM

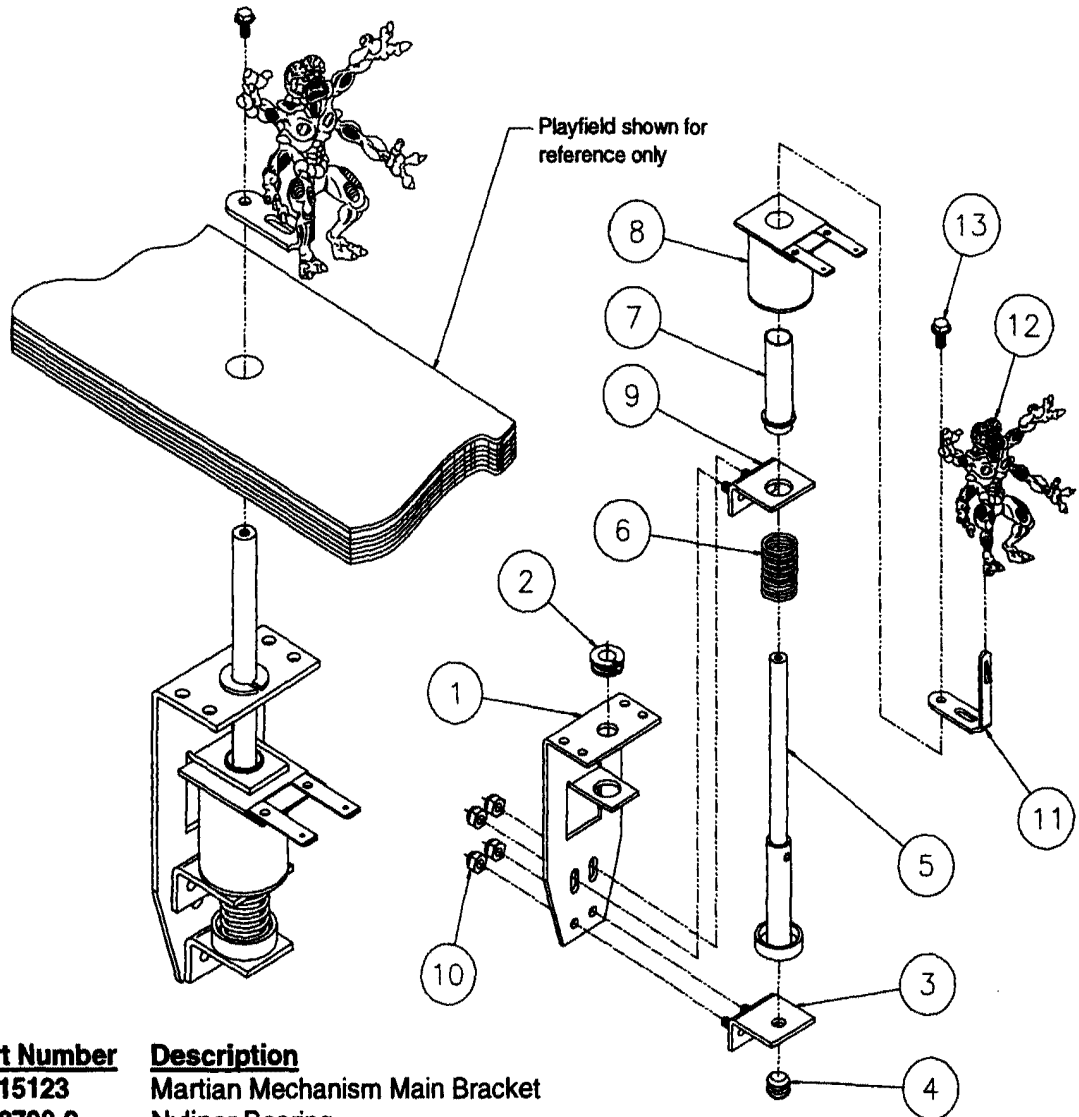
# A-22992 Ball Catcher Assembly



<b>Item</b>	<b>Part number</b>	<b>Description</b>
1	01-15193.2	Ball Catcher Main Bracket
2	01-15194	Backstop mounting Bracket
3	03-10008	Ball Catcher Backstop
4	02-5476	Ball Catcher Shaft
5	5647-12693-11	Sub Mini Micro Switch
6	01-8600	Insulator
7	01-8240	Plate Nut 2-56
8	20-8712-18	E-Ring 3/16" Shaft
9	5070-09054-00	Diode 1N4004 1.0A
10	H-23019-8	2 Pin Cable
11	4008-01220-08	MS 8-32 x 1/2" Pin Hd
12	4002-01105-08	MS 2-56 x 1/2" P-PH-S
13	10-562.1	Ball Catcher Spring
14	4408-01119-01	Nut 8-32 ESNA/NTM
15	01-15204.2	Ball Catcher Anti Ball Trap Bracket
16	4008-01227-04	MS 8-32 x 1/4" Pin Hd-SEMS



# A-22960 Martian Mechanism Assembly

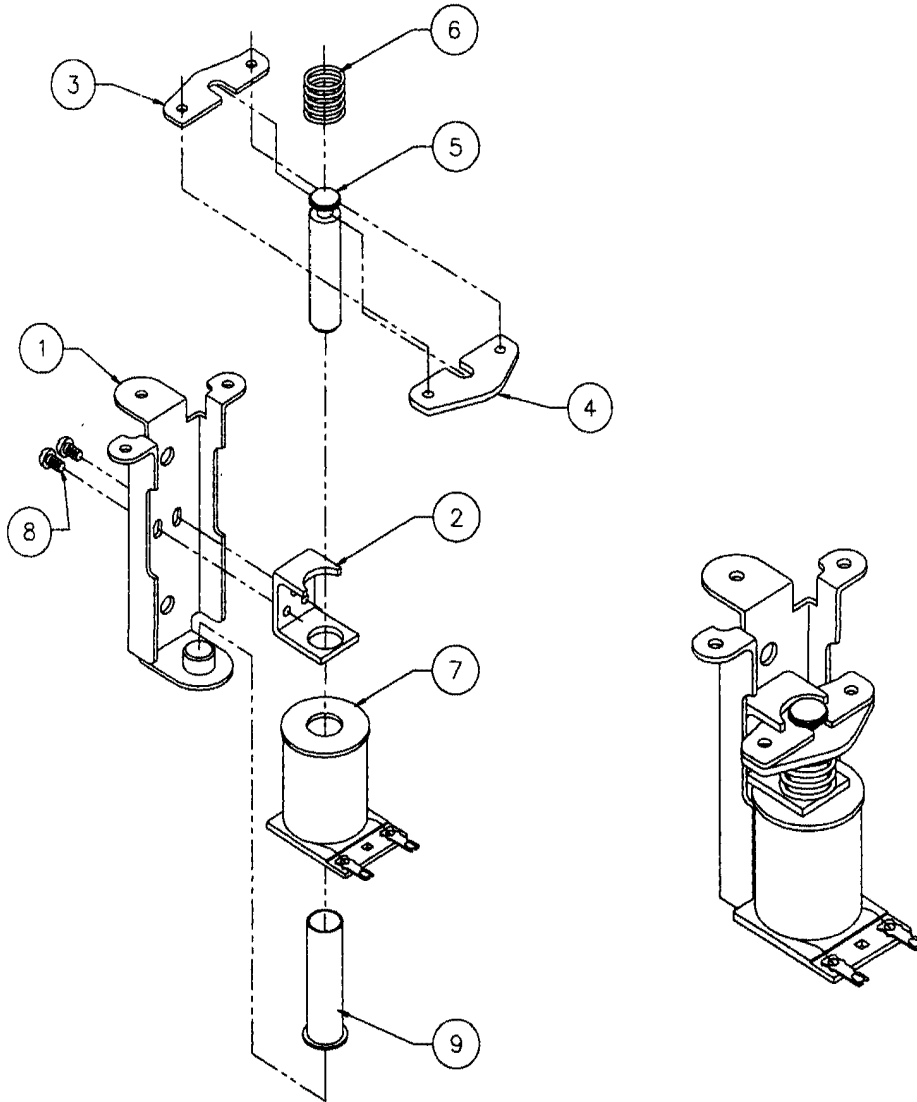


<u>Item</u>	<u>Part Number</u>	<u>Description</u>
1	01-15123	Martian Mechanism Main Bracket
2	20-8790-2	Nyliner Bearing
3	04-10910-7	Coil Centering Bracket
4	23-6420	Rubber Grommet
5	04-12595.2	Martian Plunger Assembly
6	10-135	Plunger Spring
7	03-7067	Coil Tubing
8	AE1-26-1500	Coil
9	04-10910-1	Coil Centering Bracket
10	4408-01119-01	Nut 8-32 ESNA-NTM

### Associated Parts:

<u>Item</u>	<u>Part Number</u>	<u>Description</u>
11	01-15124	Martian Retaining Bracket
12	23-6768	Martian Figurine
13	4008-01168-06	Machine Screw, 8-32 x 3/8"

## A-22205-4 Jet Coil & Bracket Assembly



<u>Item</u>	<u>Part Number</u>	<u>Description</u>
1	04-10888	Bracket and Stop Assembly
2	01-1747	Coil Retainer Bracket
3	01-5492	Armature Link (Steel)
4	01-5493	Armature Link (Bakelite)
5	02-3406-1	Coil Plunger
6	10-326	Jet Bumper Spring
7	AE1-26-1200	Coil Assembly
8	4006-01017-04	MS 6-32 x 1/4" P-RH-S
9	03-7066	Coil Tubing

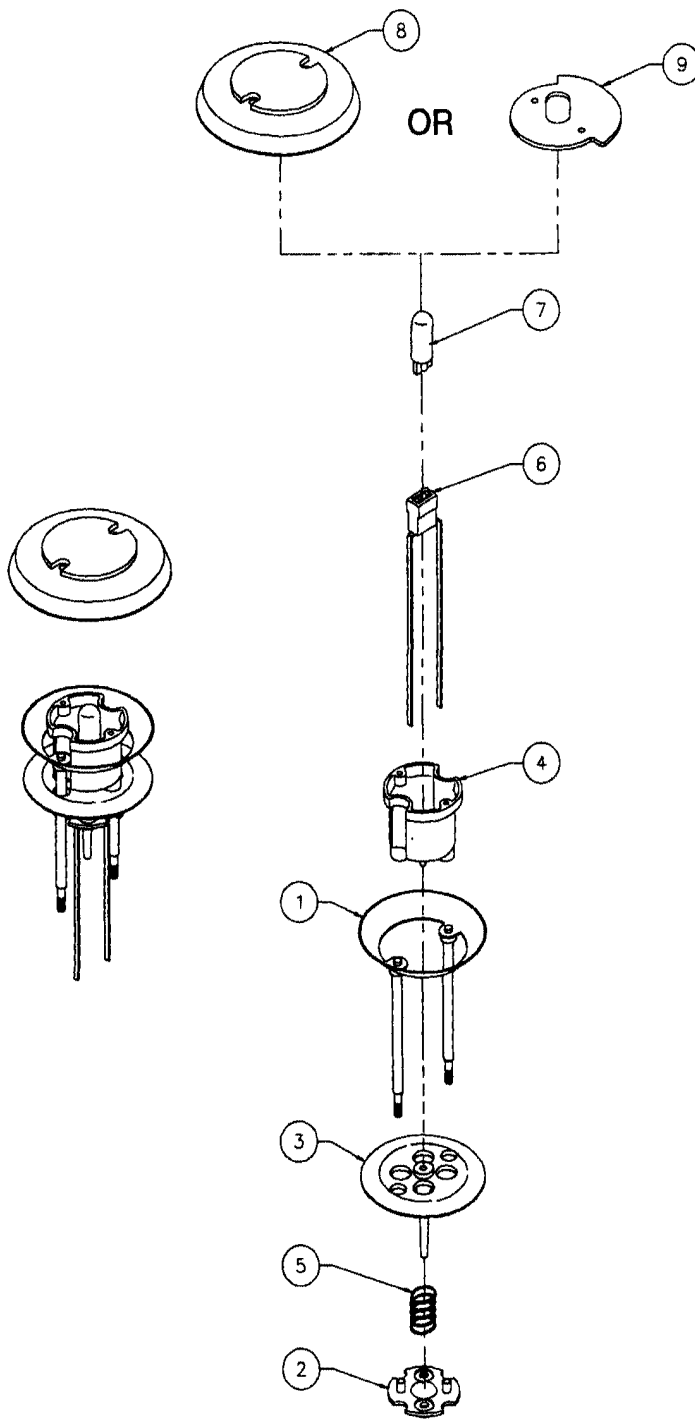
### Associated Parts: (Not Shown)

<u>Item</u>	<u>Part Number</u>	<u>Description</u>
10	A-12030-3	Jet Bumper Leaf Switch Assembly
10a)	A-16443-1	Jet Bumper Switch and Diode Assembly
10b)	01-1168	Bumper Switch Mounting Bracket
10c)	01-3670	Curved Switch Plate
10d)	03-7395	Switch Actuator
10e)	4005-01003-12	MS 5-40 x 3/4" P-PHS
10f)	4405-01117-00	Nut 5-40 Hex

# B-9414-6

## Jet Bumper Assembly

(Two B-9414-6 assemblies required. One to be used in conjunction with associated part number 03-8254-9, item 8, and the other to be used with item 9, part number 31-3437-24.)



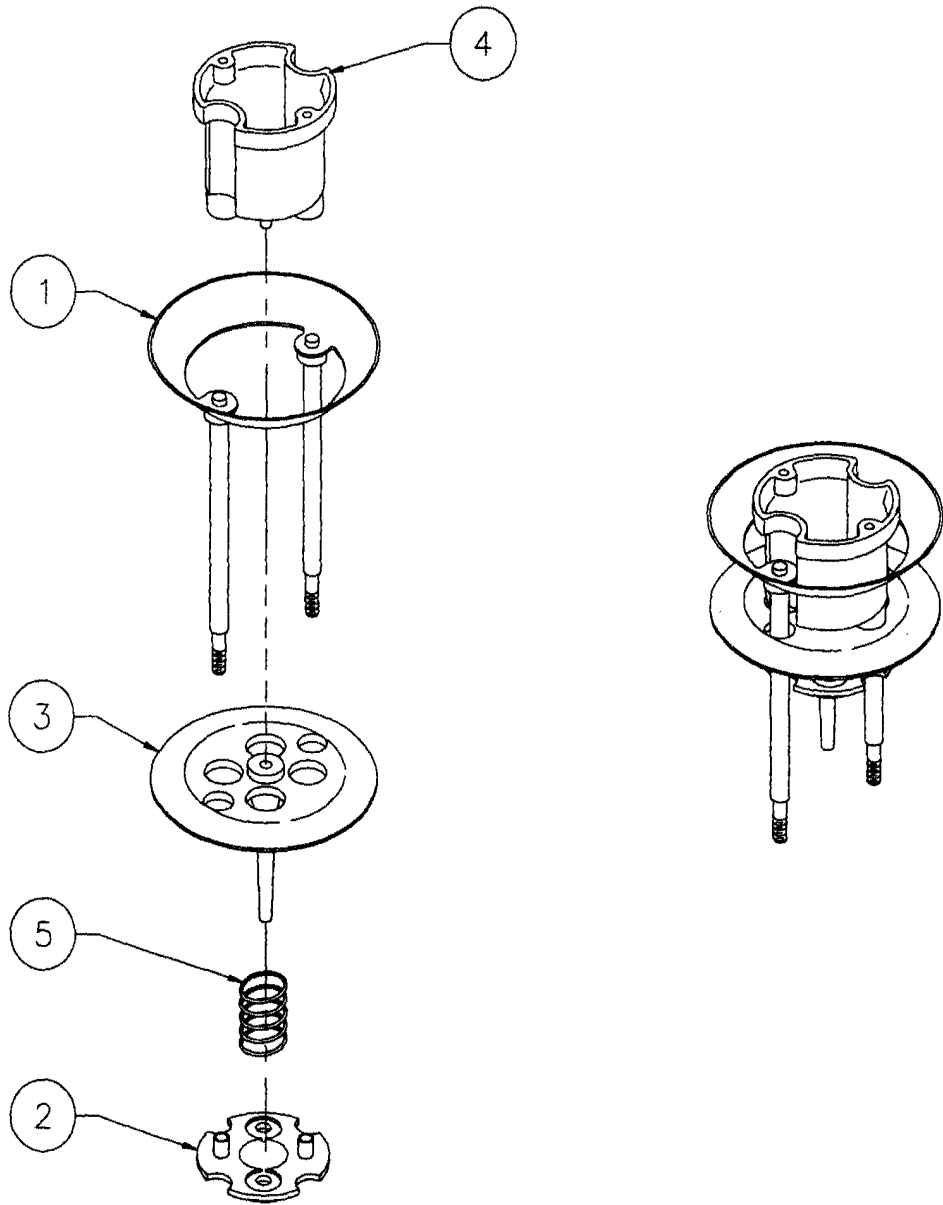
Item	Part Number	Description
1	A-4754	Bumper Ring Assembly
2	03-6009-A5	Bumper Base
3	03-6035-7	Bumper Wafer - Black
4	03-7443-5	Bumper Body
5	10-7	Spring
6	24-8776	Wedge Base Socket
7	24-8768	Bulb #555 (6.3V, 0.25A)

### Associated Parts

Item	Part Number	Description
8	03-8254-9	Jet Bumper Cap, Red
9	31-3437-24	Playfield Plastic (Ref. Only)

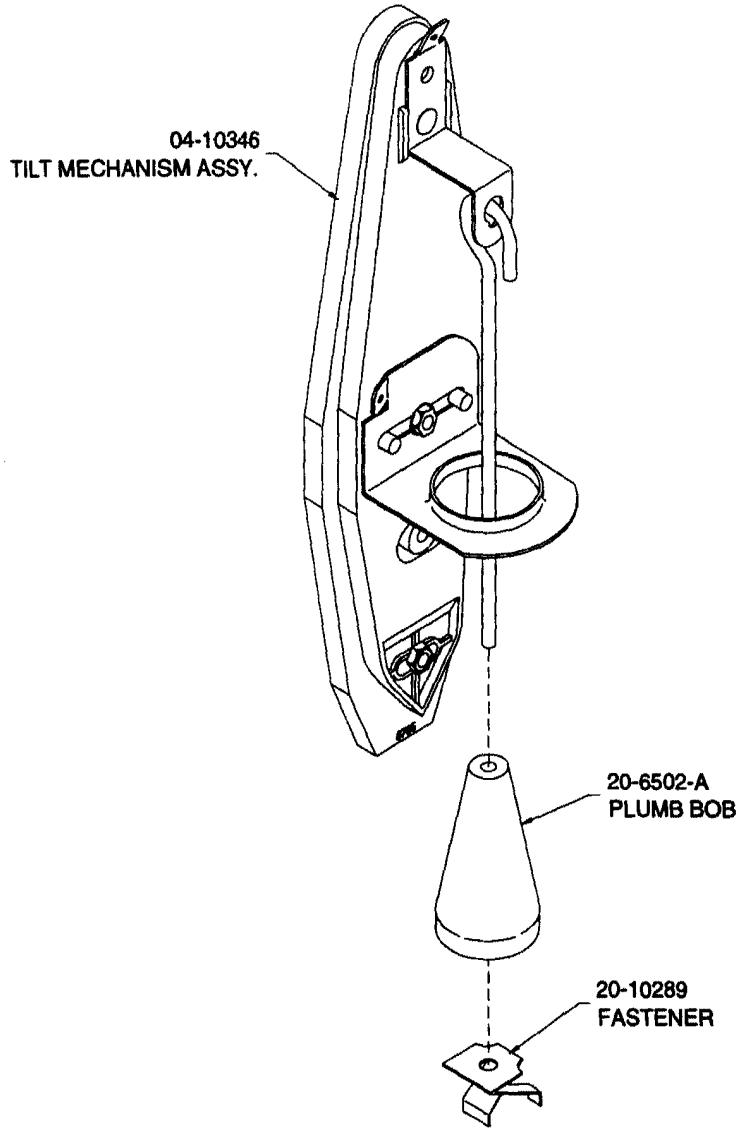
Playfield Plastic Part Shown for Reference Only.

## B-13123-2 Jet Bumper Assembly

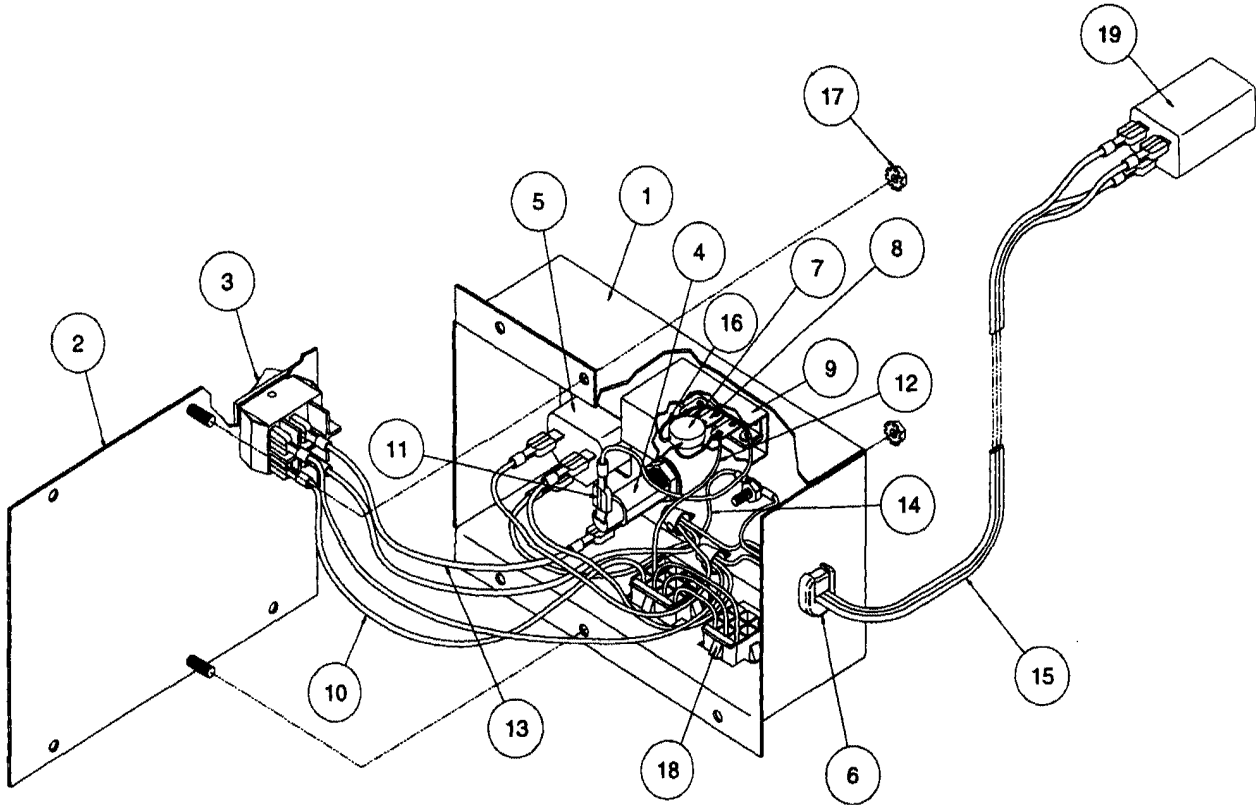


<u>Item</u>	<u>Part Number</u>	<u>Description</u>
1	A-4754	Bumper Ring Assembly
2	03-6009-A5	Bumper Base
3	03-6035-7	Bumper Wafer - Black
4	03-7443-5	Bumper Body
5	10-7	Spring

# 04-10346.1 Tilt Mechanism Assembly



## A-22966 Power Control Box Assembly



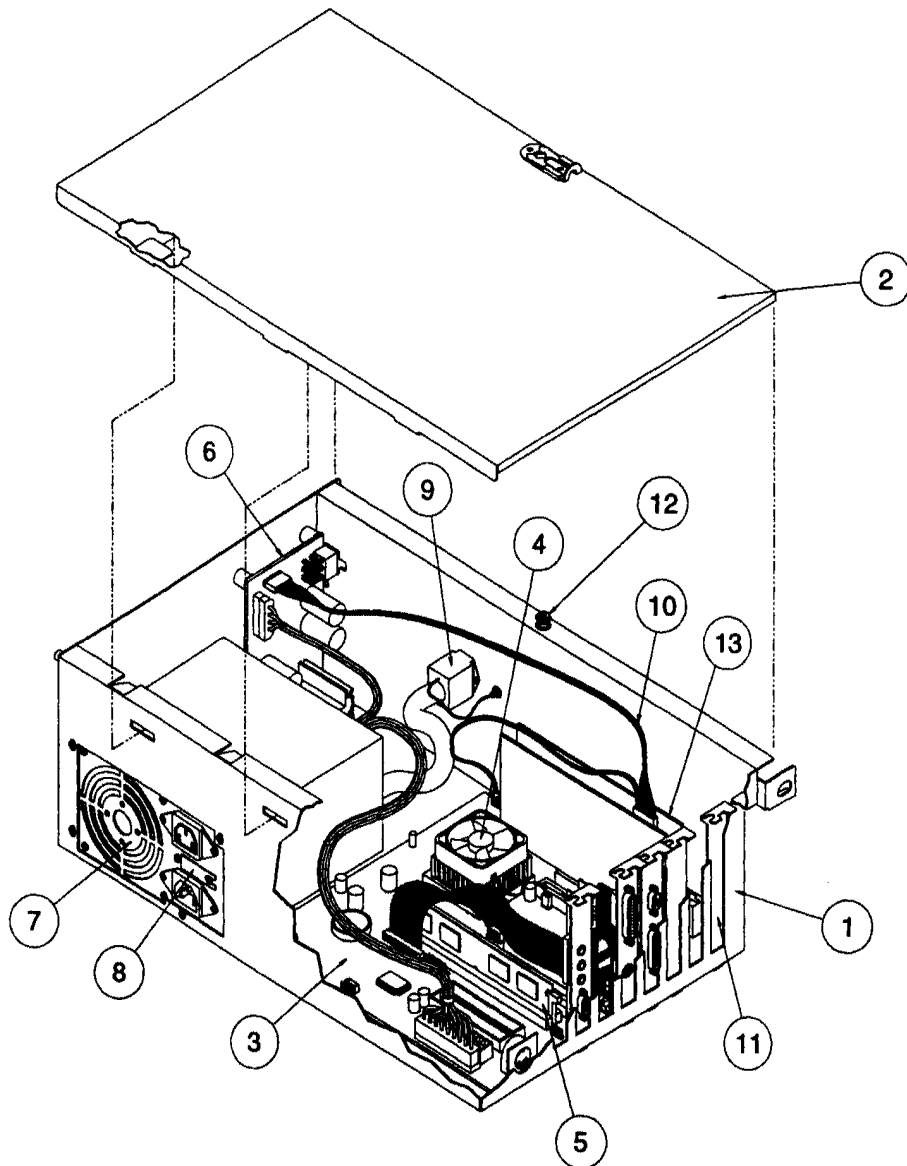
<u>Item</u>	<u>Part Number</u>	<u>Description</u>	<u>Item</u>	<u>Part Number</u>	<u>Description</u>
1	01-15126	Power Control Box	11	H-17543	Jumper, Hot Cable
2	04-12597	Switch Mounting Plate	12	H-23014	Jumper, Hot Interface
3	5642-13935-00	Rocker Switch – DPST	13	H-17545	Jumper, SW/Fuse Cable
4	5733-14734-00	Fuse Holder, 5 x 20mm	14	H-17542	Jumper, Ground Cable
5	5851-13867-00	Outlet, IEC Connector 237 Socket	15	H-23005	3 Conductor Power Cable Assembly
6	03-8712	Strain Relief Bushing	16	RM-21-06	#18 Vinyl Sleeve
7	5016-12978-00	Thermistor, 8A, 2.5R25	17	4408-01128-00	Nut, 8-32 KEPS
8	5822-13865-00	Terminal Strip, 3 CKT, 2 Mounting	18	H-22991	Transformer Programming Cable
9	01-12299	Terminal Strip Insulator	19	5102-14793-00	Line Filter
10	H-23015	Jumper, Neutral SW/1FC			

*Note: This drawing is not to be used for the purpose of wiring the Power Control box Assembly. Refer to the appropriate schematic diagram when attempting the wiring of this assembly.*

## Power Interface/Cordset Application Chart

COUNTRY	UNIVERSAL PWR. INTERFACE ASSEMBLY	VOLTAGE PROGRAMMING JUMP CABLE			4AMP FUSE	5AMP FUSE	POWER ADAPTER CORD	CORDSET											
		H-22990-1	H-22990-2	H-22990-3				5731-14530-00	5731-14046-00	5850-14052-00	5850-13271-00	5850-13272-00	5850-13273-00	5850-13274-00	5850-13275-00	5850-13276-00	5850-13277-00	5850-13278-00	A-17175-2
UNITED STATES	X	X				X	X												
CANADA	X	X				X	X												
TAIWAN	X	X				X	X												
MEXICO	X	X				X	X												
CENTRAL AMERICA	X	X				X	X												
SOUTH KOREA	X	X				X	X												
PUERTO RICO	X	X				X	X												
AUSTRIA	X		X		X						X								
BELGIUM	X		X		X						X								
FINLAND	X		X		X						X								
FRANCE	X		X		X						X								
GREECE	X		X		X						X								
HOLLAND	X		X		X						X								
HUNGARY	X		X		X						X								
NETHERLANDS	X		X		X						X								
NETH. ANTILLES	X		X		X						X								
NORWAY	X		X		X						X								
POLAND	X		X		X						X								
PORTUGAL	X		X		X						X								
SPAIN	X		X		X						X								
SWEDEN	X		X		X						X								
TURKEY	X		X		X						X								
WEST GERMANY	X		X		X						X								
UNITED KINGDOM	X		X		X							X							
IRELAND	X		X		X							X							
HONG KONG	X		X		X							X							
DENMARK	X		X		X								X						
ITALY	X		X		X									X					
CHILE	X		X		X									X					
PEOPLE'S REP. OF CHINA	X		X		X									X					
SWITZERLAND	X		X		X										X				
AUSTRALIA	X		X		X													X	
NEW ZEALAND	X		X		X													X	
ARGENTINA	X		X		X													X	
JAPAN	X			X		X												X	X
CROATIA	X		X		X						X								

# A-22724 Computer Case Assembly



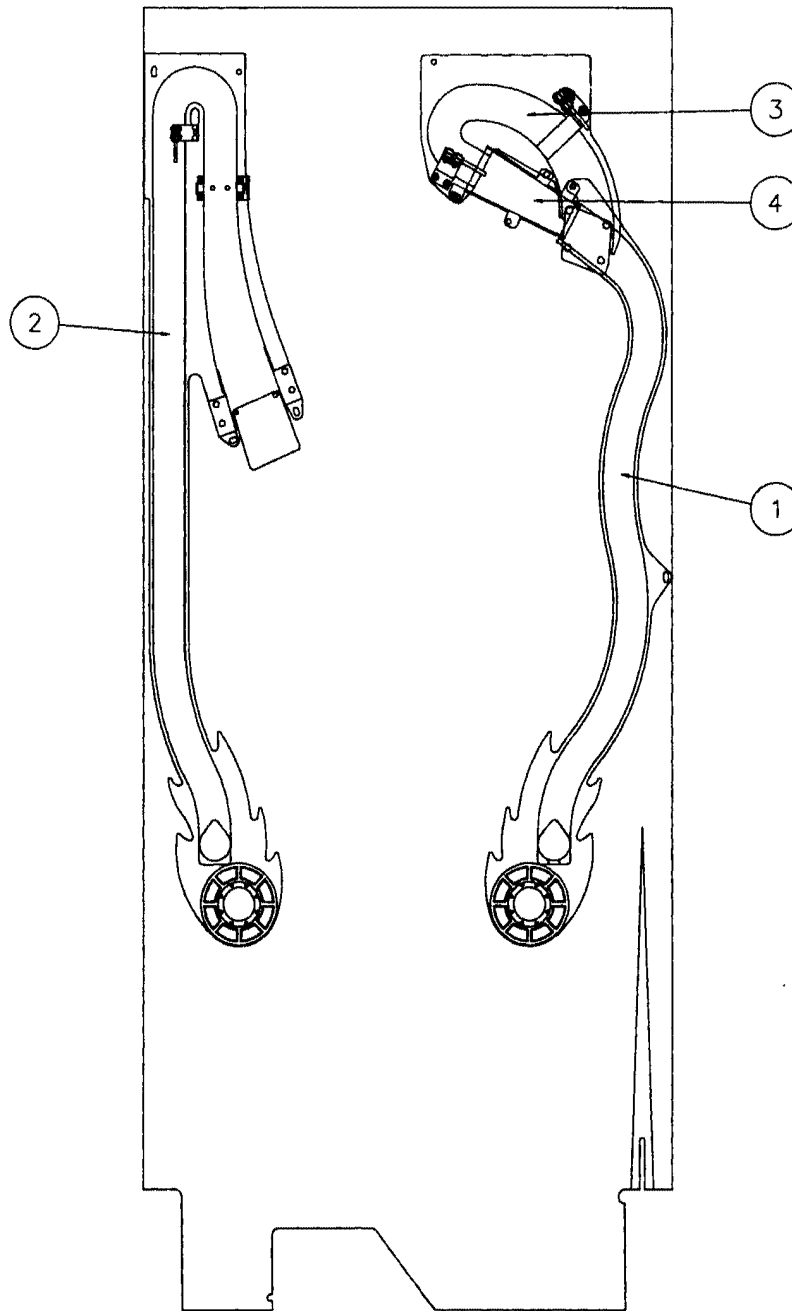
<u>Item</u>	<u>Part Number</u>	<u>Description</u>
1	04-12370.1A	Computer Case
2	A-23301	Computer Case Top Assembly
3	04-12604	Mother Board
4	20-10698	Fan/Heat Sink - Socket 7
5	04-12618	SDRAM DIMM Memory Module - 168 Pin
6	04-12621	Audio Amp Assembly
7	20-10578	Power Supply
8	01-15195	Power Supply Switch Cover
9	03-7601-4	Button Switch - Red
10	H-22978	Audio/Reset Cable
11	01-15165	Computer Case Slot Cover
12	02-5477	Bushing

### Associated Parts

<u>Item</u>	<u>Part Number</u>	<u>Description</u>
13	A-22994-50070	Prism Card Sandwich Assembly
13a	A-23171-50070	Programmed Prism Card
13b	A-22995-50070	Daughter Card w/ROM

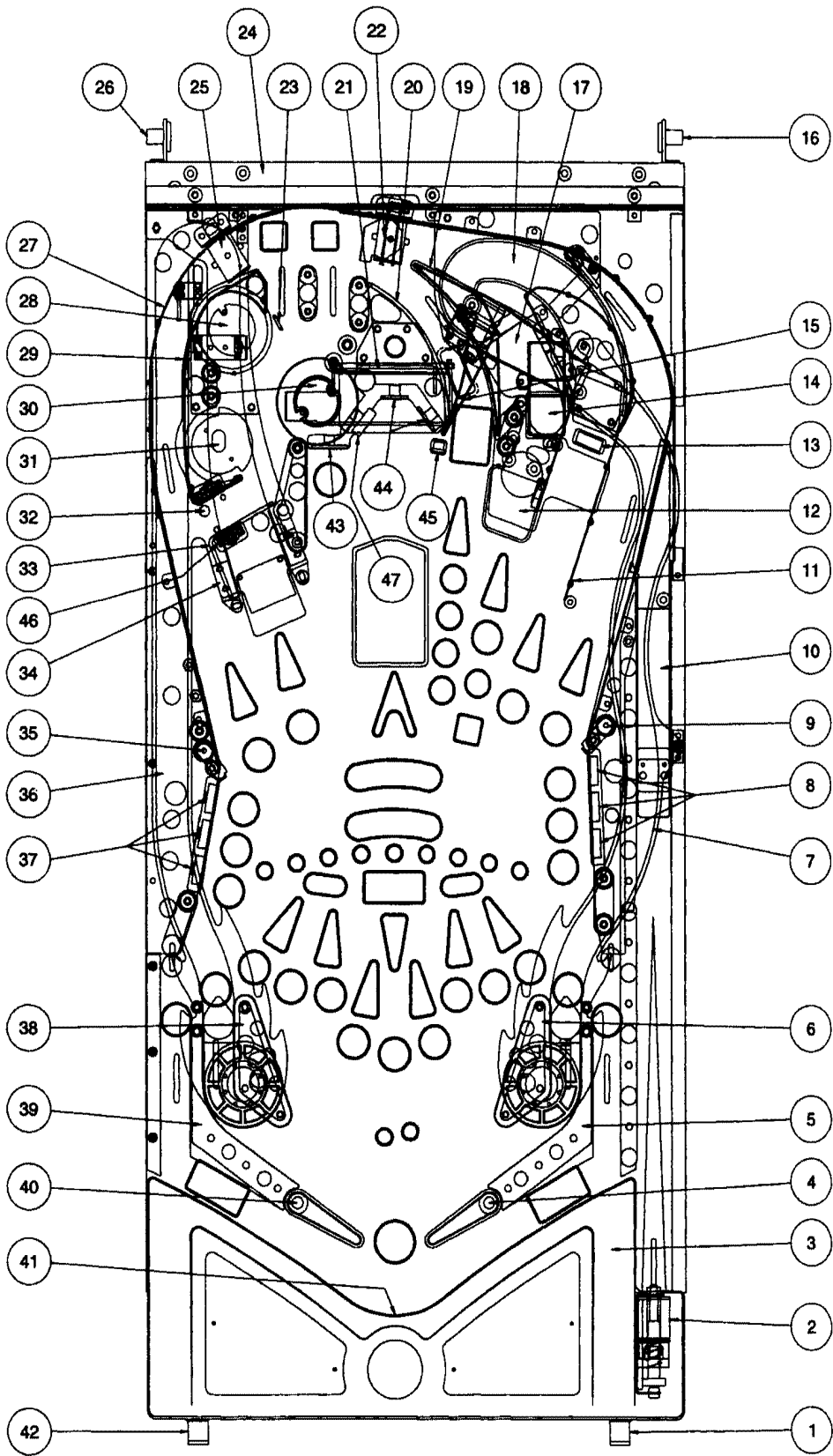


# 50070-PL Upper Playfield Ramps



<u>Item</u>	<u>Part Number</u>	<u>Description</u>
1	A-23017	Lower Right Ramp Assembly
2	A-23013	Left ramp Assembly
3	A-23016	Upper Right Ramp Assembly
4	01-15166	Bridge

# 50070-PL Upper Playfield Parts



## Upper Playfield Parts

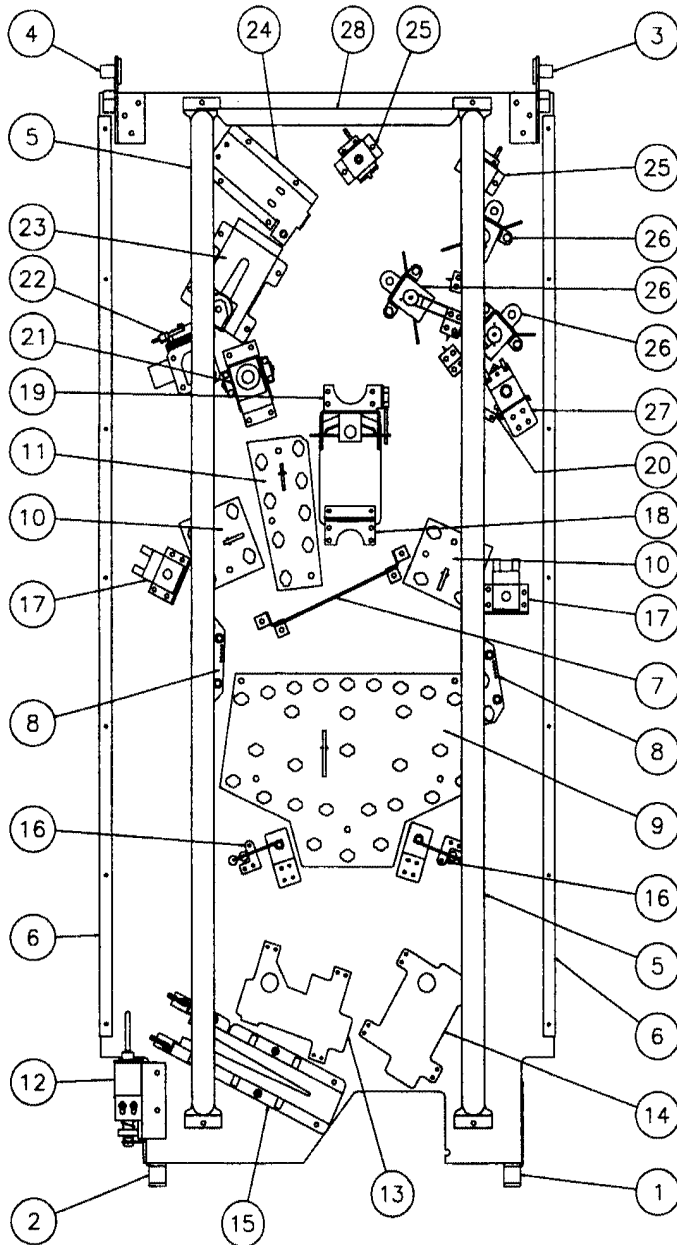
Item #	Part Number	Description
1	01-14003-2	Right Playfield Hanger
2	A-22429-4 AE1-23-800	Auto-fire Kicker Coil
3	A-23006 03-8544-1 03-9883.1-2	Bottom Arch Plastic Stud Grommet Transparent Red Arch
4	20-10110-5 A-23004-R-2 FL1-11629 SW-1A-194	Flipper Bat & Shaft Right Flipper Assembly Coil Switch
5	A-22739-1	Right Flipper Ball Guide
6	A-22207-6 AE1-26-1200 A-17801 A-17811	Slingshot Coil & Bracket Coil Slingshot Switch Assembly Slingshot Kicker Assembly
7	A-23017 03-9481-1	Right Ramp Saucer Disk w/Grn Dome
8	A-18018-21	Green Standup Targets (3)
9	A-22960 AE1-26-1500 23-6768 01-15124	Alien Mechanism Coil Alien Figurine (not shown) Retaining Bracket
10	A-23136	Shooter Ramp
11	A-22969	Ball Guide #4
12	A-23156 AE1-25-1000 A-16908 A-16909	Right Popper Assembly Coil LED Board Photo Trans. Board
13	A-15211-1 AE1-26-1200 SM1-26-600 5647-12693-31	Drop Target Assembly Up Coil Down Coil Switch
14	A-20680-1 AE1-23-800 A-16908 A-16909 04-12598	Right Lockup Popper Coil LED Board Photo Trans. Board Popper Hood
15	A-22993 FL1-22241 A-22970	Diverter Mechanism Flipper Coil-Brown Diverter Paddle Assembly
16	04-12608.1-1	Right Playfield Foot
17	01-15166	Bridge
18	A-23016 A-23140 5647-12693-36 12-7436.1 5647-12693-21	Upper Right Ramp Rollunder Gate Switch Wireform Switch
19	04-12600	Ball Guide #3
20	12-7448	Wire Ball Guide #2
21	A-22992 5647-12693-11 03-10008	Ball Catcher Switch Ball Catcher Backstop
22	A-17796 A-14406 A-17797-2 12-6657.1-R	Gate Actuator Assembly Coil Ball Gate Special Assy. Wireform
23	12-7455	Pound-in Wireform
24	A-22852	Back Panel
25	A-17796 A-14406 A-19001 12-6657.1-L	Gate Actuator Assembly Coil Ball Gate Special Assy. Wireform
26	04-12608.1-2	Left Playfield Foot
27	04-12486.2	Ball Guide #1

Item #	Part Number	Description
28	A-22205-4 AE1-26-1200 A-12030-3 B-9414-6 03-8254-9	Jet Bumper Coil Assembly Coil Jet Bumper Switch Assy. Jet Bumper Assembly Red Cap
29	04-12599	Ball Guide #2
30	A-22205-4 AE1-26-1200 A-12030-3 B-13123-2	Jet Bumper Coil Assembly Coil Jet Bumper Switch Assy. Jet Bumper Assembly
31	A-22205-4 AE1-26-1200 A-12030-3 B-9414-6	Jet Bumper Coil Assembly Coil Jet Bumper Switch Assy. Jet Bumper Assembly
32	A-22977 AE1-26-1500 A-17986	Up/Down Post Assembly Coil Bell Armature
33	12-7447	Wire Ball Guide #1
34	A-23161 12-7454	One-way Gate Assembly Wireform
35	A-22960 AE1-26-1500 23-6768 01-15124	Alien Mechanism Coil Alien Figurine (not shown) Retaining Bracket
36	A-23013 5647-12693-21 A-16908 A-16909	Left Ramp Switch LED Board Photo Trans. Board
37	A-21576-21	Green Standup Targets (3)
38	A-22207-6 AE1-26-1200 A-17801 A-17811	Slingshot Coil & Bracket Coil Slingshot Switch Assembly Slingshot Kicker Assembly
39	A-22739-2	Left Flipper Ball Guide
40	20-10110-5 A-23001-L-2 FL1-11629 SW-1A-194	Flipper Bat & Shaft Right Flipper Assembly Coil Switch
41	04-12477.1	Bottom Arch Handle
42	01-14003-2	Left Playfield Hanger
43	A-18019-11	Green Standup Target
44	A-18060-4	Red Standup Targets (2)
45	A-18530-4	Red Standup Target
46	A-23012 A-16908 A-16909	Opto Bracket LED Board Photo Trans. Board
47	A-20846-4	Red Standup Target

### Not Shown:

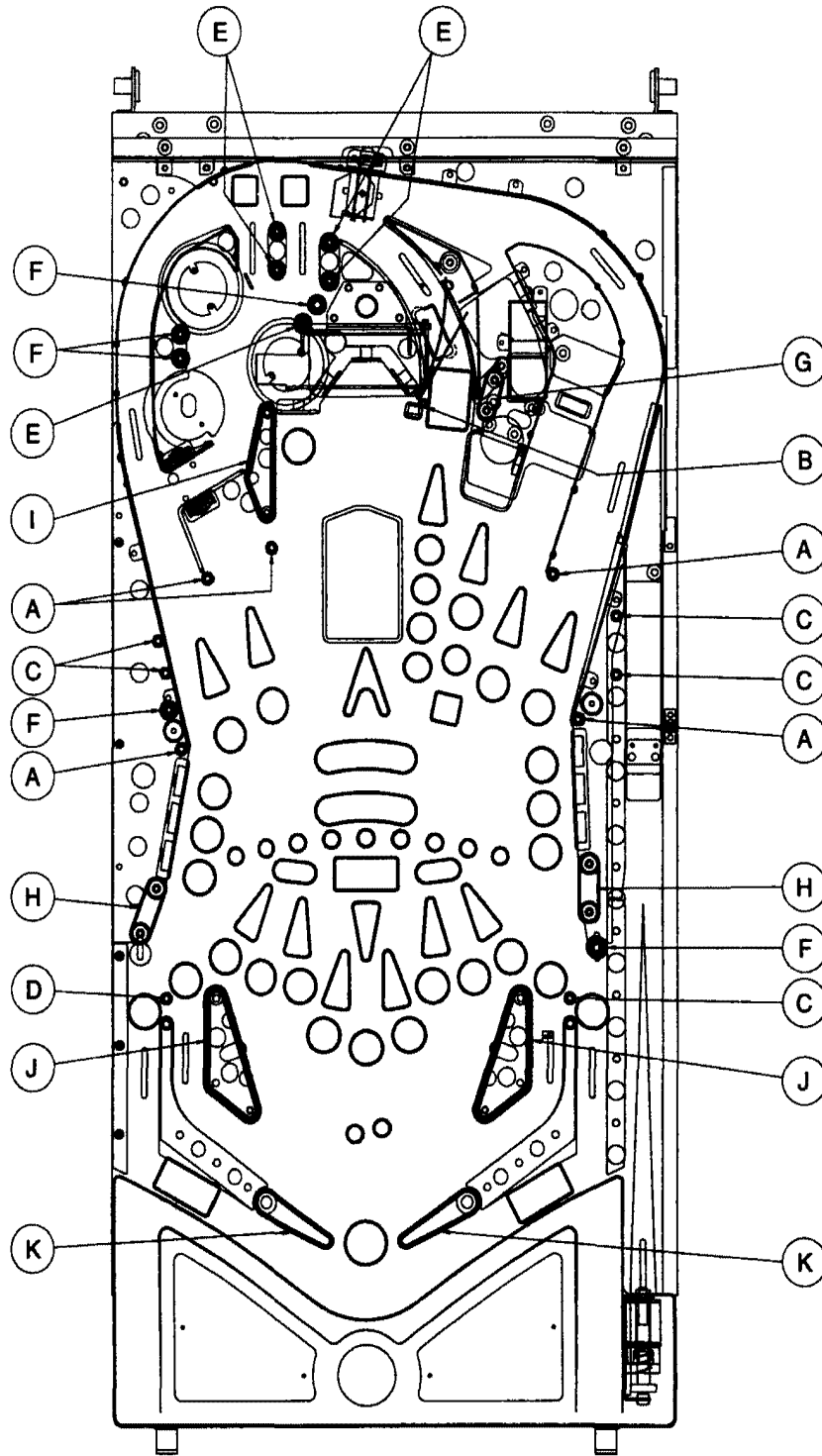
A-23167	Bottom Arch Support Bracket
01-15201.1	Playfield Side Rails (2)
03-8633	Level Mount
04-12739.1	Tinted Playfield Glass w/Decal
20-6500	1-1/16" Steel Ball (4)
20-9691	Level

# 50070-PL Lower Playfield Parts



<u>Item</u>	<u>Part Number</u>	<u>Description</u>
1	01-14003-1	Playfield Hanging Bracket - Right
2	01-14003-2	Playfield Hanging Bracket - Left
3	04-12608-1	Playfield Slide Foot - Right
4	04-12608-2	Playfield slide Foot - Left
5	01-15133.2	Playfield Support Bracket
6	01-15201.1	Playfield Side Rails
7	A-20246	10 Opto PCB Assembly w/Brackets
8	A21808-1	3-Lamp PCB Assembly w/Spacer
9	A-22987	28-Lamp PCB Assembly w/Feet
10	A-22983	4-Lamp PCB Assembly w/Feet
11	A-22986	8-Lamp PCB Assembly w/Feet
12	A-22429-4	Auto-Fire Assembly
13	A-23004-R-2	Flipper Assembly - Right
14	A-23001-L-2	Flipper Assembly - Left
15	A-19963-4	Ball Trough Assembly
16	A-17811	Kicker Assembly
	A-22206-6	Coil & Bracket Assembly
	10-128	Spring
17	A-22960	Martian Mechanism Assembly
18	A-22988	Skip Ramp Flap Assembly
	01-15140	Flap Assembly Mounting Bracket
19	A-22989	Skip Ramp Assembly
20	A-23012	Opto Bracket Assembly
21	A-23156	Popper Assembly
22	A-15211-1	1 Bank Drop Target Assembly
23	A-20680-1	3 Ball Popper Assembly
24	A-22993	Diverter Mechanism Assembly
25	A-17796	Ball Gate Actuator Assembly
26	A-22205-4	Jet Coil & Bracket Assembly
27	A-22977	Up/Down post Assembly
28	01-15125.4	Playfield Cable Bracket

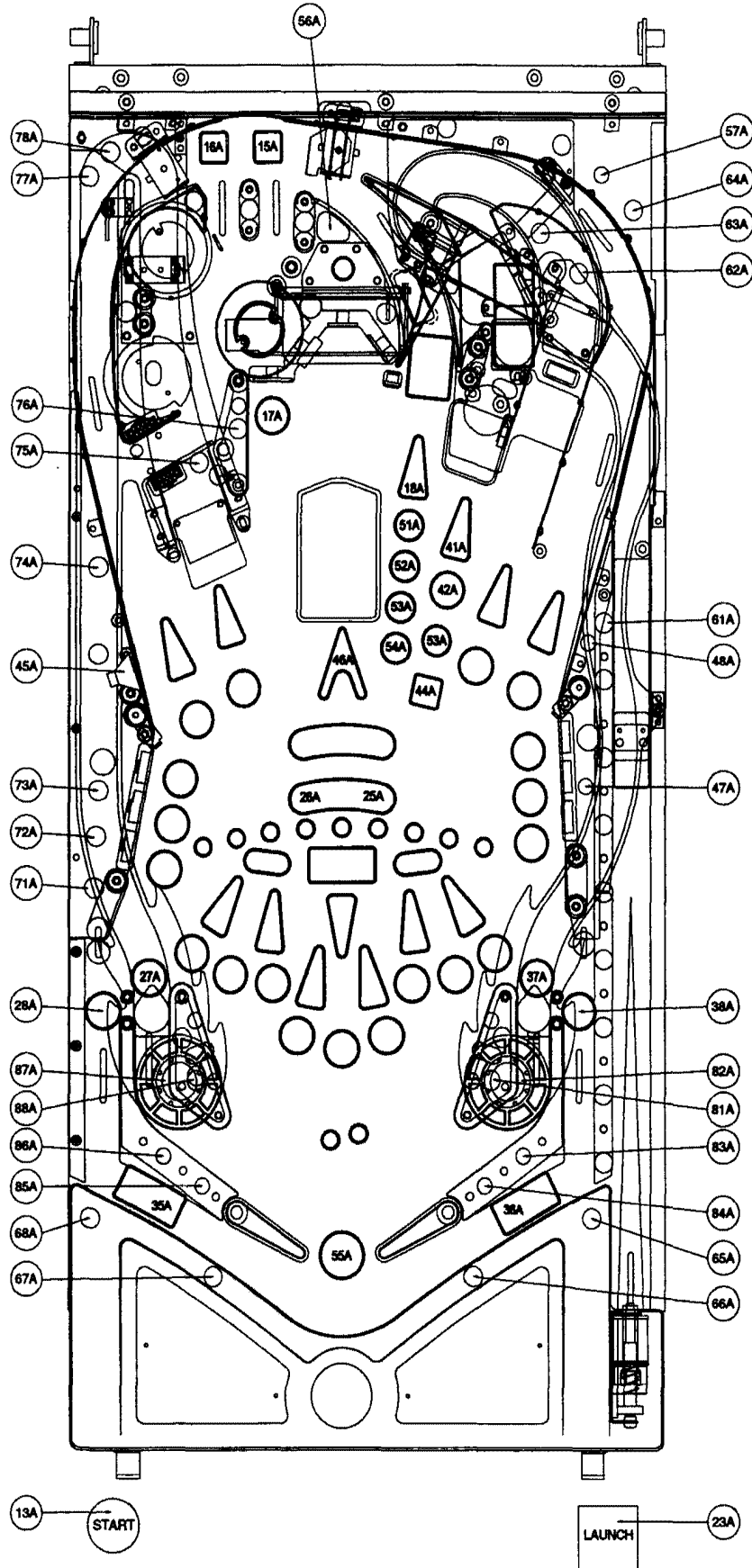
# 50070-PL Rubber Parts



<u>Item</u>	<u>Part Number</u>	<u>Description</u>	<u>Qty.</u>	<u>Item</u>	<u>Part Number</u>	<u>Description</u>	<u>Qty.</u>
A	23-6552	Yellow Rubber Bumper Sleeve	5	G	23-6694-6	1" Black Rubber Ring	1
B	23-6556	Black Rubber Bumper Sleeve	1	H	23-6694-7	1-1/4" Black Rubber Ring	2
C	23-6641	Black Rubber Bumper	5	I	23-6694-9	2" Black Rubber Ring	1
D	23-6694-1	3/32" Black Rubber Grommet	1	J	23-6694-10	2-1/2" Black Rubber Ring	2
E	23-6694-3	5/16" Black Rubber Ring	5	K	23-6695	Black Flipper Rubber Ring	2
F	23-6694-5	3/4" Black Rubber Ring	5				

# 50070-PL Lamp Locations (Matrix A)

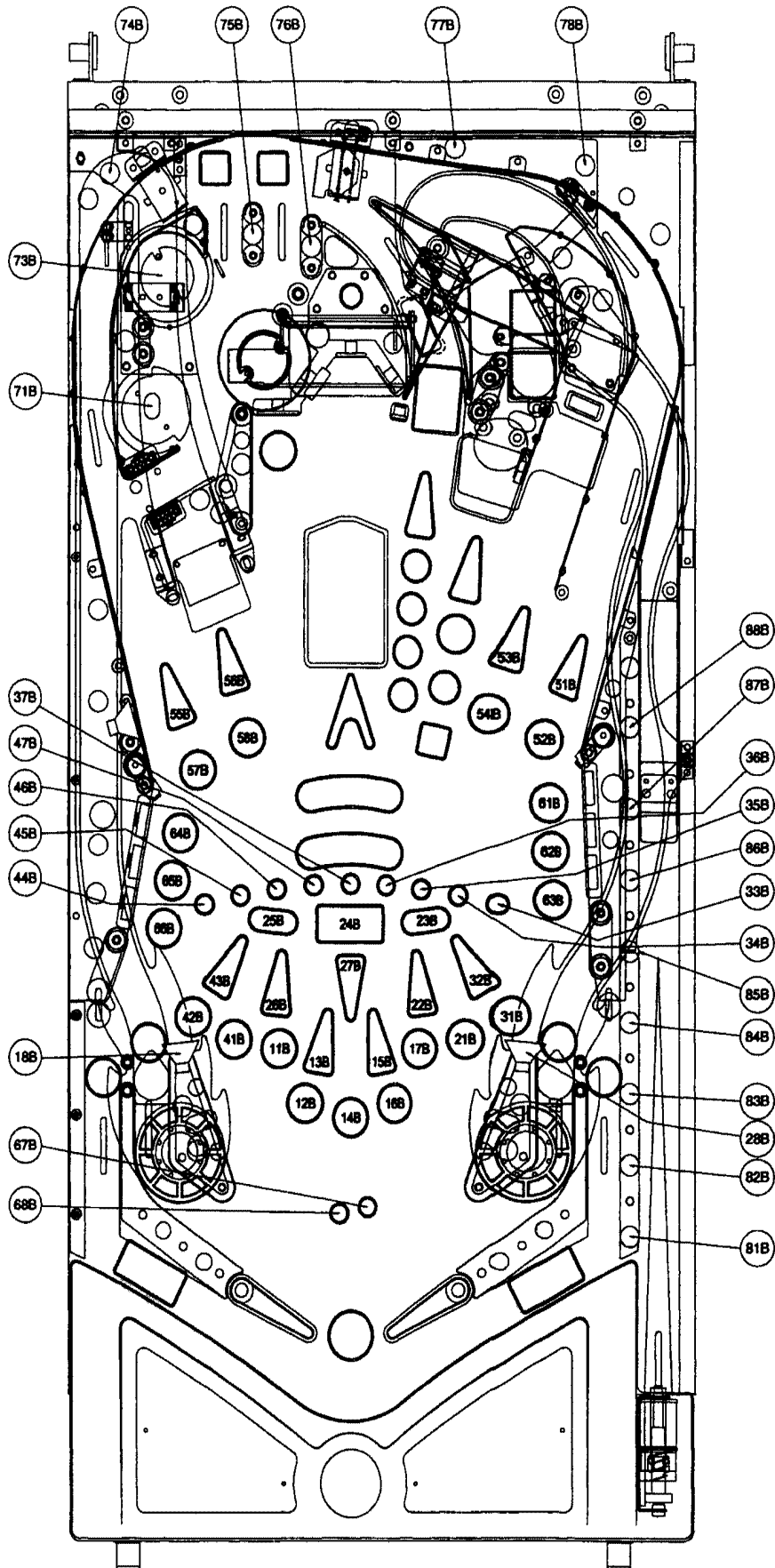
**Note:**  
Lamp, item number  
24A not shown.



## Lamp Matrix A Locations

Item Number	Lamp Assembly Part Number	Bulb Type	Bulb Part Number	Socket Part Number	Description
11A	Not Used	Not Used	Not Used	Not Used	NOT USED
12A	Not Used	Not Used	Not Used	Not Used	NOT USED
13A	20-10696	Not Sold Separate	Not Sold Separate	Not Sold Separate	START BUTTON
14A	Not Used	Not Used	Not Used	Not Used	NOT USED
15A	A-17835	#44	24-6549	Not Sold Separate	RIGHT TOP LANE
16A	A-17807	#44	24-6549	Not Sold Separate	LEFT TOP LANE
17A	A-17807	#44	24-6459	Not Sold Separate	MARTIAN TARGET 4 (CENTER)
18A	A-17835	#44	24-6549	Not Sold Separate	CENTER LOOP ARROW
21A	Not Used	Not Used	Not Used	Not Used	TICKETS LOW
22A	Not Used	Not Used	Not Used	Not Used	NOT USED
23A	20-10692-1	Not Sold Separate	Not Sold Separate	Not Sold Separate	LAUNCH BUTTON
24A	Not Sold Separate	Not Sold Separate	Not Sold Separate	Not Sold Separate	COIN DOOR ILLUMINATION
25A	A-17807	#44	24-6549	Not Sold Separate	MOTHERSHIP MULTIBALL (RIGHT)
26A	A-17807	#44	24-6549	Not Sold Separate	MOTHERSHIP MULTIBALL (LEFT)
27A	A-17835	#44	24-6549	Not Sold Separate	LEFT RETURN LANE
28A	A-17807	#44	24-6549	Not Sold Separate	LEFT OUTLANE
31A	Not Used	Not Used	Not Used	Not Used	NOT USED
32A	Not Used	Not Used	Not Used	Not Used	NOT USED
33A	Not Used	Not Used	Not Used	Not Used	NOT USED
34A	Not Used	Not Used	Not Used	Not Used	NOT USED
35A	A-17807	#44	24-6549	Not Sold Separate	LEFT DRAIN TO TROUGH
36A	A-17807	#44	24-6549	Not Sold Separate	RIGHT DRAIN TO TROUGH
37A	A-17835	#44	24-6549	Not Sold Separate	RIGHT RETURN LANE
38A	A-17835	#44	24-6549	Not Sold Separate	RIGHT OUTLANE
41A	04-12613	#555	24-8768	24-8767	RIGHT POPPER ARROW
42A	04-12613	#555	24-8768	24-8767	EXTRA BALL
43A	04-12613	#555	24-8768	24-8767	MARTIAN ATTACK
44A	04-12613	#555	24-8768	24-8767	STROKE OF LUCK
45A	04-11037-8	#555	24-8768	Not Sold Separate	LEFT SIDE SPOTLIGHT
46A	A-17807	#44	24-6549	Not Sold Separate	CENTER ARROW
47A	A-23163	#44	24-6549	Not Sold Separate	RIGHT MARTIAN (HIGH)
48A	A-23163	#44	24-6549	Not Sold Separate	RIGHT MARTIAN (LOW)
51A	04-12613	#555	24-8768	24-8767	MULTIBALL
52A	04-12613	#555	24-8768	24-8767	CAPTURE 2
53A	04-12613	#555	24-8768	24-8767	CAPTURE 1
54A	04-12613	#555	24-8768	24-8767	CATURE ZONE ACTIVE
55A	A-17807	#44	24-6549	Not Sold Separate	SHOOT AGAIN
56A	A-23163	#44	24-6549	Not Sold Separate	BEHIND CENTER TARGETS
57A	A-23163	#44	24-6549	Not Sold Separate	UPPER RIGHT CORNER (MIDDLE)
58A	Not Used	Not Used	Not Used	Not Used	NOT USED
61A	A-23163	#44	24-6549	Not Sold Separate	SHOOTER LANE 9 (TOP)
62A	A-23163	#44	24-6549	Not Sold Separate	UNDER RIGHT RAMP (LOW)
63A	A-23163	#44	24-6549	Not Sold Separate	UNDER RIGHT RAMP (HIGH)
64A	A-23163	#44	24-6549	Not Sold Separate	UPPER RIGHT CORNER (LOW)
65A	A-23163	#44	24-6549	Not Sold Separate	RIGHT ARCH (RIGHT)
66A	A-23164	#44	24-6549	Not Sold Separate	RIGHT ARCH (LEFT)
67A	A-23163	#44	24-6549	Not Sold Separate	LEFT ARCH (RIGHT)
68A	A-23163	#44	24-6549	Not Sold Separate	LEFT ARCH (LEFT)
71A	A-23163	#44	24-6549	Not Sold Separate	LEFT SIDE 1 (BOTTOM)
72A	A-23163	#44	24-6549	Not Sold Separate	LEFT SIDE 2
73A	A-23163	#44	24-6549	Not Sold Separate	LEFT SIDE 3
74A	A-23163	#44	24-6549	Not Sold Separate	LEFT SIDE 4 (TOP)
75A	A-23163	#44	24-6549	Not Sold Separate	UNDER LEFT RAMP (BOTTOM)
76A	A-23163	#44	24-6549	Not Sold Separate	UNDER LEFT RAMP (TOP)
77A	A-23163	#44	24-6549	Not Sold Separate	BETWEEN LEFT & BOTTOM JETS
78A	A-23163	#44	24-6549	Not Sold Separate	UPPER LEFT CORNER
81A	A-23163	#44	24-6549	Not Sold Separate	RIGHT SLINGSHOT (BOTTOM)
82A	A-23163	#44	24-6549	Not Sold Separate	RIGHT SLINGSHOT (SAUCER)
83A	A-23163	#44	24-6549	Not Sold Separate	RIGHT RETURN LANE (RIGHT)
84A	A-23163	#44	24-6549	Not Sold Separate	RIGHT RETURN LANE (LEFT)
85A	A-23163	#44	24-6549	Not Sold Separate	LEFT RETURN LANE (RIGHT)
86A	A-23163	#44	24-6549	Not Sold Separate	LEFT RETURN LANE (LEFT)
87A	A-23163	#44	24-6549	Not Sold Separate	LEFT SLINGSHOT (SAUCER)
88A	A-23163	#44	24-6549	Not Sold Separate	LEFT SLINGSHOT (BOTTOM)

# 50070-PL Lamp Locations (Matrix B)

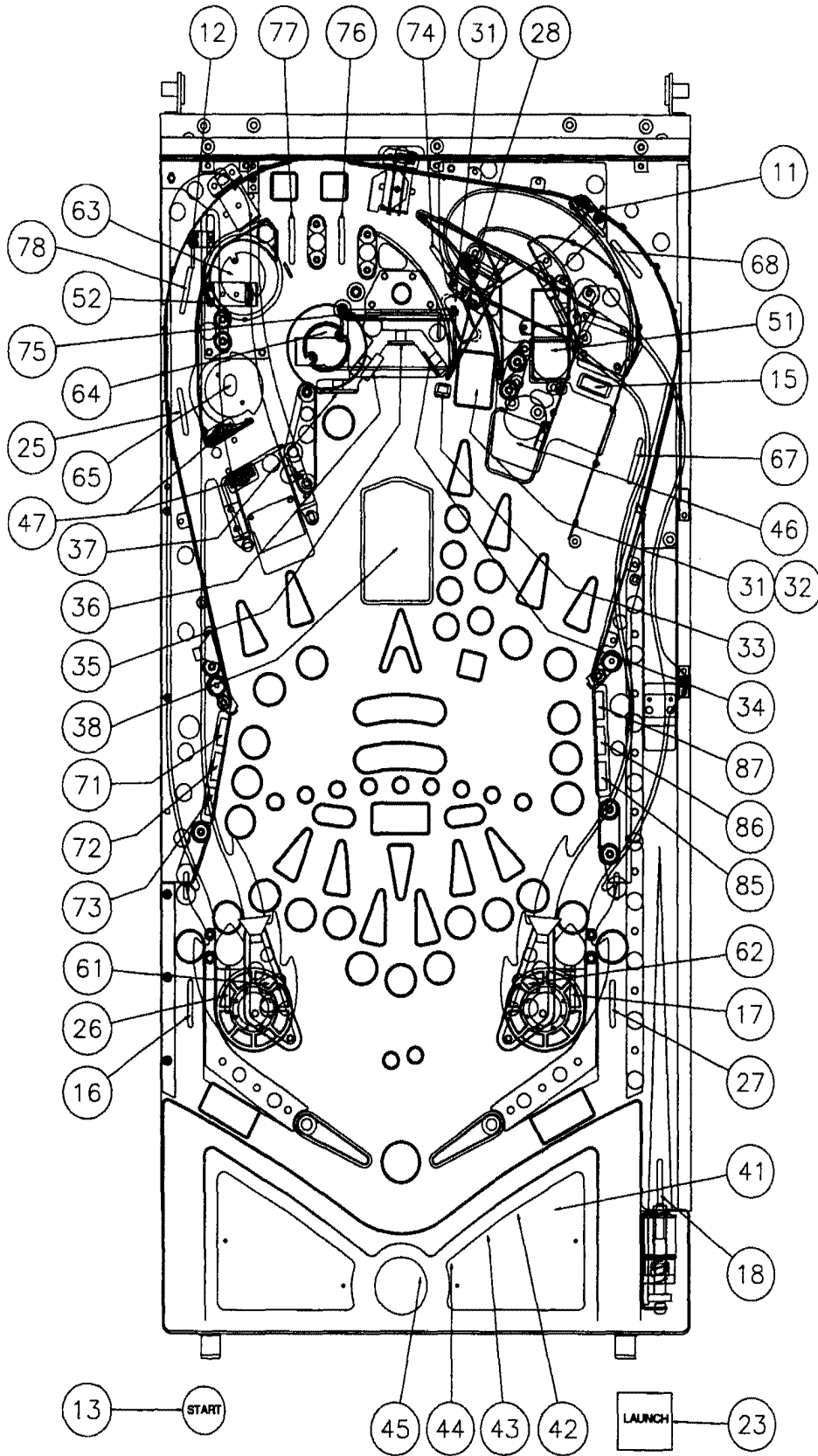




## Lamp Matrix B Locations

Item Number	Lamp Assembly Part Number	Bulb Type	Bulb Part Number	Socket Part Number	Description
11B	04-12614	#555	24-8768	24-8767	SECRET WEAPON
12B	04-12614	#555	24-8768	24-8767	TOWER STRUGGLE
13B	04-12614	#555	24-8768	24-8767	CENTER SAUCER BEAM (LEFT)
14B	04-12614	#555	24-8768	24-8767	QUESTION MARK
15B	04-12614	#555	24-8768	24-8767	CENTER SAUCER BEAM (RIGHT)
16B	04-12614	#555	24-8768	24-8767	DRIVE-IN DEMOLITION
17B	04-12614	#555	24-8768	24-8767	PARIS IN PERIL
18B	04-12860-2	#555	24-8768	Not Sold Separate	LEFT SLINGSHOT SPOTLIGHT
21B	04-12614	#555	24-8768	24-8767	BIG-O-BEAM
22B	04-12614	#555	24-8768	24-8767	RIGHT SAUCER BEAM (LEFT)
23B	04-12614	#555	24-8768	24-8767	WEAPONS
24B	04-12614	#555	24-8768	24-8767	SAUCER
25B	04-12614	#555	24-8768	24-8767	FUEL
26B	04-12614	#555	24-8768	24-8767	LEFT SAUCER BEAM (RIGHT)
27B	04-12614	#555	24-8768	24-8767	CENTER SAUCER BEAM (CENTER)
28B	04-12860-2	#555	24-8768	Not Sold Separate	RIGHT SLINGSHOT SPOTLIGHT
31B	04-12614	#555	24-8768	24-8767	MARS KNEADS WOMEN
32B	04-12614	#555	24-8768	24-8767	RIGHT SAUCER BEAM (RIGHT)
33B	04-12614	#555	24-8768	24-8767	SAUCER RIM 9 (RIGHT)
34B	04-12614	#555	24-8768	24-8767	SAUCER RIM 8
35B	04-12614	#555	24-8768	24-8767	SAUCER RIM 7
36B	04-12614	#555	24-8768	24-8767	SAUCER RIM 6
37B	04-12614	#555	24-8768	24-8767	SAUCER RIM 5
38B	Not Used	Not Used	Not Used	Not Used	NOT USED
41B	04-12614	#555	24-8768	24-8767	MARTIAN HAPPY HOUR
42B	04-12614	#555	24-8768	24-8767	ALIEN ABDUCTION
43B	04-12614	#555	24-8768	24-8767	LEFT SAUCER BEAM (LEFT)
44B	04-12614	#555	24-8768	24-8767	SAUCER RIM 1 (LEFT)
45B	04-12614	#555	24-8768	24-8767	SAUCER RIM 2
46B	04-12614	#555	24-8768	24-8767	SAUCER RIM 3
47B	04-12614	#555	24-8768	24-8767	SAUCER RIM 4
48B	Not Used	Not Used	Not Used	Not Used	NOT USED
51B	04-12611	#555	24-8768	24-8767	RIGHT LOOP ARROW
52B	04-12611	#555	24-8768	24-8767	RIGHT LOOP CIRCLE
53B	04-12611	#555	24-8768	24-8767	RIGHT RAMP ARROW
54B	04-12611	#555	24-8768	24-8767	RIGHT RAMP CIRCLE
55B	04-12611	#555	24-8768	24-8767	LEFT LOOP ARROW
56B	04-12611	#555	24-8768	24-8767	LEFT RAMP ARROW
57B	04-12611	#555	24-8768	24-8767	LEFT LOOP CIRCLE
58B	04-12611	#555	24-8768	24-8767	LEFT RAMP CIRCLE
61B	A-21808	#555	24-8768	24-8767	MARTIAN TARGET 5 (RIGHT TOP)
62B	A-21808	#555	24-8768	24-8767	MARTIAN TARGET 6 (RIGHT MID.)
63B	A-21808	#555	24-8768	24-8767	MARTIAN TARGET 7 (RIGHT BOT.)
64B	A-21808	#555	24-8768	24-8767	MARTIAN TARGET 3 (LEFT TOP)
65B	A-21808	#555	24-8768	24-8767	MARTIAN TARGET 2 (LEFT MID.)
66B	A-21808	#555	24-8768	24-8767	MARTIAN TARGET 1 (LEFT BOT.)
67B	A-17835	#44	24-6549	Not Sold Separate	RIGHT MARTIAN EYE
68B	A-17835	#44	24-6549	Not Sold Separate	LEFT MARTIAN EYE
71B	---	#555	24-8768	24-8776	BOTTOM JET BUMPER
72B	Not Used	Not Used	Not Used	Not Used	NOT USED
73B	---	#555	24-8768	24-8776	LEFT JET BUMPER
74B	A-23163	#44	24-6549	Not Sold Separate	LEFT OF LEFT TOP LANE
75B	A-23163	#44	24-6549	Not Sold Separate	BETWEEN LEFT/RIGHT TOP LANES
76B	A-23163	#44	24-6549	Not Sold Separate	RIGHT OF RIGHT TOP LANES
77B	A-23163	#44	24-6549	Not Sold Separate	TOP OF CENTER LOOP
78B	A-23163	#44	24-6549	Not Sold Separate	UPPER RIGHT CORNER (HIGH)
81B	A-23163	#44	24-6549	Not Sold Separate	SHOOTER LANE 1 (BOTTOM)
82B	A-23163	#44	24-6549	Not Sold Separate	SHOOTER LANE 2
83B	A-23163	#44	24-6549	Not Sold Separate	SHOOTER LANE 3
84B	A-23163	#44	24-6549	Not Sold Separate	SHOOTER LANE 4
85B	A-23163	#44	24-6549	Not Sold Separate	SHOOTER LANE 5
86B	A-23163	#44	24-6549	Not Sold Separate	SHOOTER LANE 6
87B	A-23163	#44	24-6549	Not Sold Separate	SHOOTER LANE 7
88B	A-17807	#44	24-6549	Not Sold Separate	SHOOTER LANE 8

# 50070-PL Playfield Switch Locations

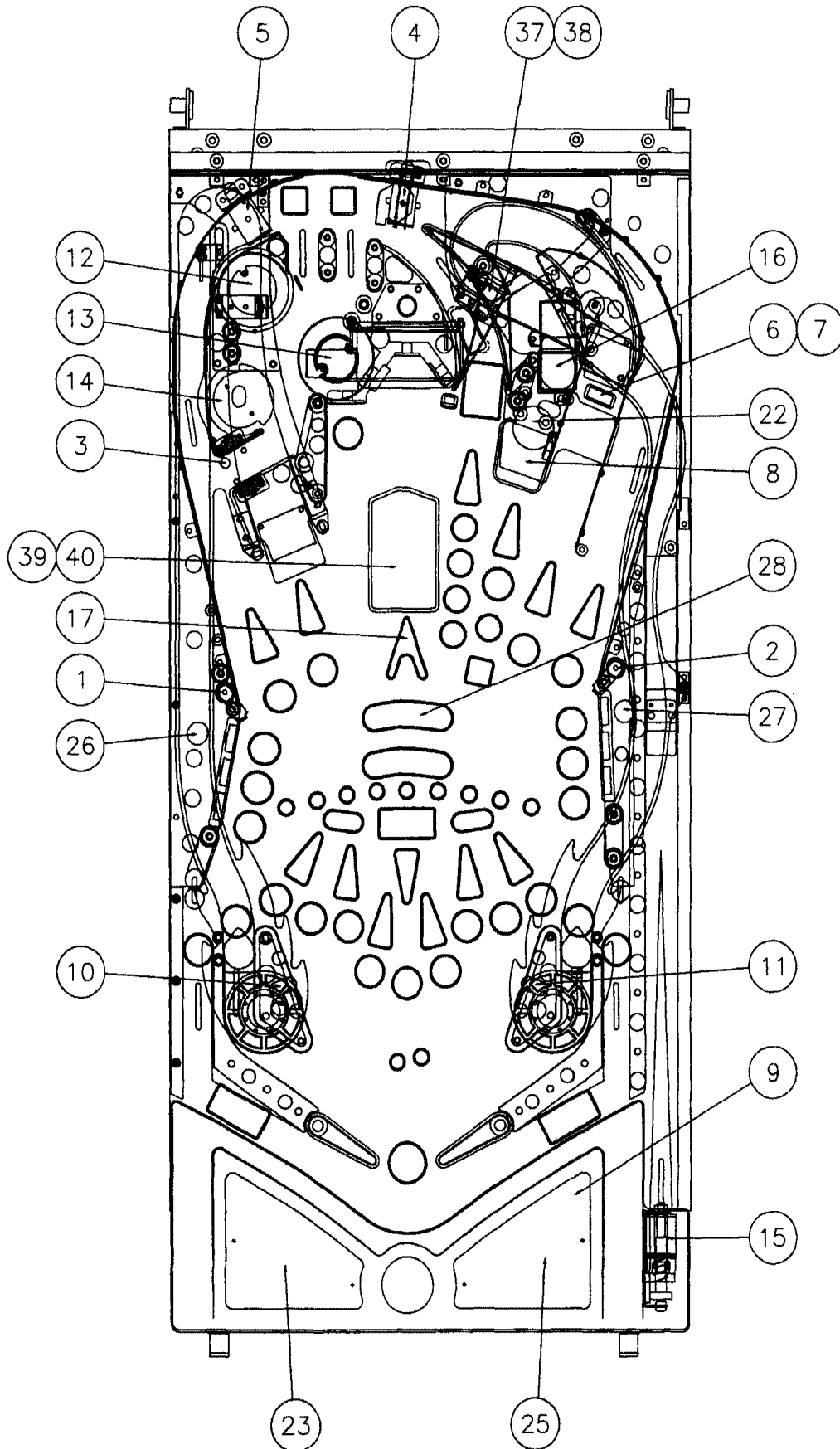


## Switch Locations

Item Number	Switch Assembly Part Number <i>OR</i> Opto Assembly Part Number	Switch Part Number	Description
D13	---	SW-1A-194	*LOWER RIGHT FLIPPER E.O.S.
D14	---	SW-1A-194	*LOWER LEFT FLIPPER E.O.S.
D15	NOT USED	NOT USED	UPPER RIGHT FLIPPER E.O.S.
D16	NOT USED	NOT USED	UPPER LEFT FLIPPER E.O.S.
D21	A-22984	---	*LOWER RIGHT FLIPPER CABINET BUTTON
D22	A-22984	---	*LOWER LEFT FLIPPER CABINET BUTTON
D23	A-22984	---	RIGHT ACTION BUTTON
D24	A-22984	---	LEFT ACTION BUTTON
11	A-23140	5647-12693-36	RIGHT RAMP ENTRANCE
12	---	5647-12693-21	LEFT RAMP EXIT
13	20-10696	---	START BUTTON
14	NOT USED	NOT USED	NOT USED
15	---	5647-12693-31	DROP TARGET DOWN
16	A-17813-1	5647-12693-19	LEFT OUTLANE
17	A-17813	5647-12693-19	RIGHT RETURN LANE
18	A-18973	5647-12693-32	SHOOTER LANE
21	NOT USED	NOT USED	NOT USED
22	NOT USED	NOT USED	NOT USED
23	20-10692-1	---	LAUNCH BUTTON
24	NOT USED	NOT USED	NOT USED
25	A-17813-1	5647-12693-19	LEFT LOOP (LOW)
26	A-17813	5647-12693-19	LEFT RETURN LANE
27	A-17813	5647-12693-19	RIGHT OUTLANE
28	---	5647-12693-21	RIGHT RAMP EXIT
31	20-10293	---	CENTER LOOP REED (BOTTOM)
32	20-10293	---	CENTER LOOP REED (TOP)
33	A-18530-4	---	CENTER TARGET 4
34	A-18060-4	---	CENTER TARGET 3
35	A-18060-4	---	CENTER TARGET 2
36	A-20848-4	---	CENTER TARGET 1
37	A-18019-11	---	MARTIAN TARGET 4 (CENTER)
38	---	5647-12693-07	UP/DOWN RAMP UP
41	A-18617-1 (LED) A-18618-1 (PHOTO TRANS)	---	TROUGH EJECT
42	A-18617-1 (LED) A-18618-1 (PHOTO TRANS)	---	TROUGH BALL 1
43	A-18617-1 (LED) A-18618-1 (PHOTO TRANS)	---	TROUGH BALL 2
44	A-18617-1 (LED) A-18618-1 (PHOTO TRANS)	---	TROUGH BALL 3
45	A-18617-1 (LED) A-18618-1 (PHOTO TRANS)	---	TROUGH BALL 4
46	A-16908 (LED) A-16909 (PHOTO TRANS)	---	RIGHT POPPER
47	A-16908 (LED) A-16909 (PHOTO TRANS)	---	JET EXIT
48	NOT USED	NOT USED	NOT USED
51	A-16908 (LED) A-16909 (PHOTO TRANS)	---	RIGHT LOCKUP 1
52	A-16908 (LED) A-16909 (PHOTO TRANS)	---	LEFT RAMP ENTRANCE
53	NOT USED	NOT USED	NOT USED
54	NOT USED	NOT USED	NOT USED
55	NOT USED	NOT USED	NOT USED
56	NOT USED	NOT USED	NOT USED
57	NOT USED	NOT USED	NOT USED
58	NOT USED	NOT USED	NOT USED
61	A-17801	A-17800 (KICK) A-17794 (SCORE)**	LEFT SLINGSHOT
62	A-17801	A-17800 (KICK) A-17794 (SCORE)**	RIGHT SLINGSHOT
63	B-12030-3	A-16443-1	LEFT JET BUMPER
64	B-12030-3	A-16443-1	RIGHT JET BUMPER
65	B-12030-3	A-16443-1	BOTTOM JET BUMPER
66	NOT USED	NOT USED	NOT USED
67	A-17813	5647-12693-19	RIGHT LOOP (LOW)
68	A-17813	5647-12693-19	RIGHT LOOP (HIGH)
71	A-21576-21	---	MARTIAN TARGET 3 (LEFT TOP)
72	A-21576-21	---	MARTIAN TARGET 2 (LEFT MIDDLE)
73	A-21576-21	---	MARTIAN TARGET 1 (LEFT BOTTOM)
74	A-17813-1	5647-12693-19	CENTER LOOP ROLLOVER
75	---	5647-12693-11	CENTER DEFLECTOR PANEL
76	A-17813	5647-12693-19	RIGHT TOP LANE
77	A-17813	5647-12693-19	LEFT TOP LANE
78	A-17813	5647-12693-19	LEFT LOOP (HIGH)
81	NOT USED	NOT USED	NOT USED
82	NOT USED	NOT USED	NOT USED
83	NOT USED	NOT USED	NOT USED
84	NOT USED	NOT USED	NOT USED
85	A-18018-21	---	MARTIAN TARGET 7 (RIGHT BOTTOM)
86	A-18018-21	---	MARTIAN TARGET 6 (RIGHT MIDDLE)
87	A-18018-21	---	MARTIAN TARGET 5 (RIGHT TOP)
88	NOT USED	NOT USED	NOT USED

\*NOT SHOWN. \*\*SCORE SWITCHES HAVE DIODES ATTACHED.

# 50070-PL Solenoid/Flasher Locations



## Solenoid/Flasher Locations

Item Number	Assembly Part Number	Coil or Flasher Part Number	Description
01	A-22960	AE1-26-1500	LEFT MARTIAN
02	A-22960	AE1-26-1500	RIGHT MARTIAN
03	A-22977	AE1-26-1500	JET EXIT POST
04	A-17796	A-14406	RIGHT GATE
05	A-17796	A-14406	LEFT GATE
06	A-15211-1	SM1-26-600	DROP TARGET DOWN
07	A-15211-1	AE1-26-1200	DROP TARGET UP
08	A-23156	AE1-25-1000	RIGHT POPPER
09	A-19963-4	AE1-26-1500	TROUGH EJECT
10	A-22207-6	AE1-26-1200	LEFT SLINGSHOT
11	A-22207-6	AE1-26-1200	RIGHT SLINGSHOT
12	A-22205-4	AE1-26-1200	LEFT JET BUMPER
13	A-22205-4	AE1-26-1200	RIGHT JET BUMPER
14	A-22205-4	AE1-26-1200	BOTTOM JET BUMPER
15	A-22429-4	AE1-23-800	AUTO PLUNGER
16	A-20680-1	AE1-23-800	RIGHT LOCKUP
17	A-17802	24-8802 (#906)	CENTER ARROW FLASHER
18	NOT USED	NOT USED	NOT USED
19	NOT USED	NOT USED	NOT USED
20	NOT USED	NOT USED	NOT USED
21	NOT USED	NOT USED	NOT USED
22	----	24-8802 (#906)	RIGHT POPPER FLASHER
23	A-17983	24-8704 (#89)	LEFT ARCH FLASHER
24	NOT USED	NOT USED	NOT USED
25	A-17983	24-8704 (#89)	RIGHT ARCH FLASHER
26	A-17983	24-8704 (#89)	LEFT MARTIAN FLASHER
27	A-17983	24-8704 (#89)	RIGHT MARTIAN FLASHER
28	A-17802	24-8802 (#906)	ATTACK MARS FLASHER

### Flipper Circuits

	Assembly Part Number	Coil Part Number	Description
33-34	A-23004-R-2	FL1-11629	LOWER RIGHT FLIPPER
35-36	A-23001-L-2	FL1-11629	LOWER LEFT FLIPPER
37-38	A-22993	FL1-22241	LOCK DIVERTER
39-40	A-22989	FL1-11753	UP/DOWN RAMP

## LAMP MATRIX A

COLUMN	1A YEL-BRN J108-9 Q5	2A YEL-RED J108-10 Q9	3A YEL-ORG J108-11 Q13	4A YEL-BLK J108-12 Q17	5A YEL-GRN J108-13 Q21	6A YEL-BLU J108-14 Q25	7A YEL-VIO J108-15 Q29	8A YEL-GRY J108-16 Q33
ROW								
1A BRN-BLK J108-1 Q3	NOT USED 11A	TICKETS LOW 21A	NOT USED 31A	RIGHT POPPER ARROW 41A	MULTIBALL 51A	SHOOTER LANE 9 (TOP) 61A	LEFT SIDE 1 (BOTTOM) 71A	RIGHT SLINGSHOT (BOTTOM) 81A
2A BRN-RED J108-2 Q7	NOT USED 12A	NOT USED 22A	NOT USED 32A	EXTRA BALL 42A	CAPTURE 2 52A	UNDER RIGHT RAMP (LOW) 62A	LEFT SIDE 2 72A	RIGHT SLINGSHOT (SAUCER) 82A
3A BRN-ORG J108-3 Q11	START BUTTON 13A	LAUNCH BUTTON 23A	NOT USED 33A	MARTIAN ATTACK 43A	CAPTURE 1 53A	UNDER RIGHT RAMP (HIGH) 63A	LEFT SIDE 3 73A	RIGHT RETURN LANE (RIGHT) 83A
4A BRN-YEL J108-4 Q15	NOT USED 14A	COIN DOOR ILLUMINA. 24A	NOT USED 34A	STROKE OF LUCK 44A	CAPTURE ZONE ACTIVE 54A	UPPER RT. CORNER (LOW) 64A	LEFT SIDE 4 (TOP) 74A	RIGHT RETURN LANE (LEFT) 84A
5A BRN-GRN J108-5 Q19	RIGHT TOP LANE 15A	MOTHERSHIP MULTIBALL (RIGHT) 25A	LEFT DRAIN TO TROUGH 35A	LEFT SIDE SPOTLIGHT 45A	SHOOT AGAIN 55A	RIGHT ARCH (RIGHT) 65A	UNDER LEFT RAMP (BOTTOM) 75A	LEFT RETURN LANE (RIGHT) 85A
6A BRN-BLU J108-6 Q23	LEFT TOP LANE 16A	MOTHERSHIP MULTIBALL (LEFT) 26A	RIGHT DRAIN TO TROUGH 36A	CENTER ARROW 46A	BEHIND CENTER TARGETS 56A	RIGHT ARCH (LEFT) 66A	UNDER LEFT RAMP (TOP) 76A	LEFT RETURN LANE (LEFT) 86A
7A BRN-VIO J108-7 Q27	MARTIAN TARGET 4 (CENTER) 17A	LEFT RETURN LANE 27A	RIGHT RETURN LANE 37A	RIGHT MARTIAN (HIGH) 47A	UPPER RT. CORNER (MIDDLE) 57A	LEFT ARCH (RIGHT) 67A	BETWEEN L/B JETS 77A	LEFT SLINGSHOT (SAUCER) 87A
8A BRN-GRY J108-8 Q31	CENTER LOOP ARROW 18A	LEFT OUTLANE 28A	RIGHT OUTLANE 38A	RIGHT MARTIAN (LOW) 48A	NOT USED 58A	LEFT ARCH (LEFT) 68A	UPPER LEFT CORNER 78A	LEFT SLINGSHOT (BOTTOM) 88A

## LAMP MATRIX B

COLUMN	1B YEL-BRN J107-10 Q6	2B YEL-RED J107-11 Q10	3B YEL-ORG J107-12 Q14	4B YEL-BLK J107-13 Q18	5B YEL-GRN J107-14 Q22	6B YEL-BLU J107-15 Q26	7B YEL-VIO J107-16 Q30	8B YEL-GRY J107-17 Q34
ROW								
1B RED-BRN J107-1 Q4	SECRET WEAPON 11B	BIG-O-BEAM 21B	MARS KNEADS WOMEN 31B	MARTIAN HARRY HOUR 41B	RIGHT LOOP ARROW 51B	MARTIAN TARGET 5 (RT. TOP) 61B	BOTTOM JET BUMPER 71B	SHOOTER LANE 1 (BOTTOM) 81B
2B RED-BLK J107-2 Q8	TOWER STRUGGLE 12B	RIGHT SAUCER BEAM (LEFT) 22B	RIGHT SAUCER BEAM (RT) 32B	ALIEN ABDUCTION 42B	RIGHT LOOP CIRCLE 52B	MARTIAN TARGET 6 (RT. MID.) 62B	NOT USED 72B	SHOOTER LANE 2 82B
3B RED-ORG J107-3 Q12	CENTER SAUCER BEAM (LEFT) 13B	WEAPONS 23B	SAUCER RIM 9 (RIGHT) 33B	LEFT SAUCER BEAM (LEFT) 43B	RIGHT RAMP ARROW 53B	MARTIAN TARGET 7 (RT. BOT.) 63B	LEFT JET BUMPER 73B	SHOOTER LANE 3 83B
4B RED-YEL J107-4 Q16	QUESTION MARK 14B	SAUCER 24B	SAUCER RIM 8 34B	SAUCER RIM 1 (LEFT) 44B	RIGHT RAMP CIRCLE 54B	MARTIAN TARGET 3 (LEFT TOP) 64B	LEFT OF LEFT TOP LANE 74B	SHOOTER LANE 4 84B
5B RED-GRN J107-5 Q20	CENTER SAUCER BEAM (RT.) 15B	FUEL 25B	SAUCER RIM 7 35B	SAUCER RIM 2 45B	LEFT LOOP ARROW 55B	MARTIAN TARGET 2 (LEFT MID.) 65B	BETWEEN L/R TOP LANES 75B	SHOOTER LANE 5 85B
6B RED-BLU J107-6 Q24	DRIVE-IN DEMOLITION 16B	LEFT SAUCER BEAM (RT.) 26B	SAUCER RIM 6 36B	SAUCER RIM 3 46B	LEFT RAMP ARROW 56B	MARTIAN TARGET 1 (LEFT BOT.) 66B	RIGHT OF RIGHT TOP LANE 76B	SHOOTER LANE 6 86B
7B RED-VIO J107-7 Q28	PARIS IN PERIL 17B	CENTER SAUCER BEAM (CNTR) 27B	SAUCER RIM 5 37B	SAUCER RIM 4 47B	LEFT LOOP CIRCLE 57B	RIGHT MARTIAN EYE 67B	TOP OF CENTER LOOP 77B	SHOOTER LANE 7 87B
8B RED-GRY J107-8 Q32	LEFT SLINGSHOT SPOTLIGHT 18B	RIGHT SLINGSHOT SPOTLIGHT 28B	NOT USED 38B	NOT USED 48B	LEFT RAMP CIRCLE 58B	LEFT MARTIAN EYE 68B	UPPER RT. CORNER (HIGH) 78B	SHOOTER LANE 8 88B

## SWITCH MATRIX

COLUMN	1 GRN-BRN J116-1 U45-18	2 GRN-RED J116-2 U45-17	3 GRN-ORG J116-3 U45-16	4 GRN-WHT J116-4 U45-15	5 GRN-BLK J116-5 U45-14	6 GRN-BLU J116-6 U45-13	7 GRN-VIO J116-7 U45-12	8 GRN-GRY J116-8 U45-11
ROW	1 WHT-BRN J116-12 U51-7	2 WHT-RED J116-13 U51-5	3 WHT-ORG J116-14 U51-9	4 WHT-YEL J116-15 U51-11	5 WHT-GRN J116-16 U57-7	6 WHT-BLU J116-17 U57-5	7 WHT-VIO J116-18 U57-9	8 WHT-GRY J116-19 U57-11
	RIGHT RAMP ENTRANCE 11	NOT USED 21	CENTER LOOP REED (BOTTOM) 31	TROUGH JAM 41	RIGHT LOCKUP 1 51	LEFT SLINGSHOT 61	MARTIAN TARGET 3 (LEFT TOP) 71	NOT USED 81
	LEFT RAMP EXIT 12	NOT USED 22	CENTER LOOP REED (TOP) 32	TROUGH BALL 1 42	LEFT RAMP ENTRANCE 52	RIGHT SLINGSHOT 62	MARTIAN TARGET 2 (LEFT MID.) 72	NOT USED 82
	START BUTTON 13	LAUNCH BUTTON 23	CENTER TARGET 4 33	TROUGH BALL 2 43	NOT USED 53	LEFT JET BUMPER 63	MARTIAN TARGET 1 (LEFT BOT.) 73	NOT USED 83
	NOT USED 14	NOT USED 24	CENTER TARGET 3 34	TROUGH BALL 3 44	NOT USED 54	RIGHT JET BUMPER 64	CENTER LOOP ROLLOVER 74	NOT USED 84
	DROP TARGET DOWN 15	LEFT LOOP (LOW) 25	CENTER TARGET 2 35	TROUGH BALL 4 45	NOT USED 55	BOTTOM JET BUMPER 65	CENTER DEFLECTOR PANEL 75	MARTIAN TARGET 7 (RT. BOT.) 85
	LEFT OUTLANE 16	LEFT RETURN LANE 26	CENTER TARGET 1 36	RIGHT POPPER 46	NOT USED 56	NOT USED 66	RIGHT TOP LANE 76	MARTIAN TARGET 6 (RT. MID.) 86
	RIGHT RETURN LANE 17	RIGHT OUTLANE 27	MARTIAN TARGET 4 (CENTER) 37	JET EXT 47	NOT USED 57	RIGHT LOOP (LOW) 67	LEFT TOP LANE 77	MARTIAN TARGET 5 (RT. TOP) 87
	SHOOTER LANE 18	RIGHT RAMP EXIT 28	UP/DOWN RAMP UP 38	NOT USED 48	NOT USED 58	RIGHT LOOP (HIGH) 68	LEFT LOOP (HIGH) 78	NOT USED 88

= OPTO, TYPICALLY CLOSED

## COIN SLOT SWITCHES

DIRECT GROUND	ORN-BRN J114-1 U43-7	ORG-RED J114-2 U43-5	ORG-BLK J114-3 U43-9	ORG-YEL J114-4 U43-11	ORG-GRN J114-5 U48-7	ORG-BLU J114-6 U48-5	ORG-VIO J114-8 U48-9	ORG-GRY J114-9 U48-11
BLACK J114-14	LEFT COIN SLOT D1	CENTER COIN SLOT D2	RIGHT COIN SLOT D3	4 <sup>TH</sup> COIN OPTION D4	NOT USED D5	NOT USED D6	NOT USED D7	NOT USED D8

## DIAGNOSTIC SWITCHES SWITCHES (E.O.S.)

DIRECT GROUND	GRY-BLK J114-10 U50-7	GRY-ORG J114-11 U50-5	GRY-RED J114-12 U50-9	GRY-BRN J114-13 U50-11
BLACK J114-14	'ESCAPE' BUTTON D9	'DOWN' BUTTON D10	'UP' BUTTON D11	'ENTER' BUTTON D12

## PLAYFIELD FLIPPER

DIRECT GROUND	BLK-GRN J115-9 U56-7	BLK-BLU J115-10 U56-5	BLK-VIO J115-20 U56-9	BLK-GRY J115-21 U56-11
BLACK J115-22	LOWER RIGHT FLIPPER E.O.S. D13	LOWER LEFT FLIPPER E.O.S. D14	NOT USED D15	NOT USED D16

## CABINET FLIPPER SWITCHES

DIRECT GROUND	BLK-BRN J113-1 U49-7	BLK-RED J113-2 U49-5	BLK-ORG J113-3 U49-9	BLK-YEL J113-4 U49-11	BLK-GRN J113-6 U55-7	BLK-BLU J113-7 U55-5	BLK-VIO J113-8 U55-9	BLK-GRY J113-9 U55-11
BLACK J113-10	SLAM TILT D17	COIN DOOR CLOSED D18	PLUMB BOB TILT D19	NOT USED D20	RIGHT FLIPPER BUTTON D21	LEFT FLIPPER BUTTON D22	RIGHT ACTION BUTTON D23	LEFT ACTION BUTTON D24

## SOLENOID TABLE

Sol No.	Solenoid Function	Fuse	Power to Playfield	Power Wire Color	Drive Transistor	Drive to Playfield	Drive Wire Color	Solenoid Part Number or Flasher Type
01	LEFT MARTIAN	F101	J102-1	RED-BRN	Q59	J110-13	VIO-BRN	AE1-26-1500
02	RIGHT MARTIAN	F101	J102-1	RED-BRN	Q60	J110-14	VIO-RED	AE1-26-1500
03	JET EXIT POST	F101	J102-1	RED-BRN	Q61	J110-15	VIO-ORG	AE1-26-1500
04	RIGHT GATE	F101	J102-1	RED-BRN	Q62	J110-16	VIO-YEL	A-14406
05	LEFT GATE	F102	J102-2	RED-BLK	Q63	J110-17	VIO-GRN	A-14406
06	DROP TARGET DOWN	F102	J102-2	RED-BLK	Q64	J110-18	VIO-BLU	SM1-26-600
07	DROP TARGET UP	F102	J102-2	RED-BLK	Q65	J110-19	VIO-BLK	AE1-26-1200
08	RIGHT POPPER	F102	J102-2	RED-BLK	Q66	J110-20	VIO-GRY	AE1-25-1000
09	TROUGH EJECT	F103	J102-3	RED-ORG	Q51	J112-11	BRN-BLK	AE1-26-1500
10	LEFT SLINGSHOT	F103	J102-3	RED-ORG	Q52	J112-12	BRN-RED	AE1-26-1200
11	RIGHT SLINGSHOT	F103	J102-3	RED-ORG	Q53	J112-13	BRN-ORG	AE1-26-1200
12	LEFT JET BUMPER	F103	J102-3	RED-ORG	Q54	J112-14	BRN-YEL	AE1-26-1200
13	RIGHT JET BUMPER	F100	J102-7	RED-YEL	Q55	J112-15	BRN-GRN	AE1-26-1200
14	BOTTOM JET BUMPER	F100	J102-7	RED-YEL	Q56	J112-16	BRN-BLU	AE1-26-1200
15	AUTO PLUNGER	F100	J102-7	RED-YEL	Q57	J112-17	BRN-VIO	AE1-23-800
16	RIGHT LOCKUP	F100	J102-7	RED-YEL	Q58	J112-18	BRN-GRY	AE1-23-800
17	CENTER ARROW FLASHER	F109	J102-8	RED-WHT	Q43	J110-1	BLU-BRN	#906
18	NOT USED	F109			Q44	J110-2	BLU-RED	
19	NOT USED	F109			Q45	J110-3	BLU-ORG	
20	NOT USED	F109			Q46	J110-4	BLU-YEL	
21	NOT USED	F109			Q47	J110-5	BLU-GRN	
22	RIGHT POPPER FLASHER	F109	J102-8	RED-WHT	Q48	J110-6	BLU-BLK	#906
23	LEFT ARCH FLASHER	F109	J102-8	RED-WHT	Q49	J110-7	BLU-VIO	#89
24	NOT USED	F109			Q50	J110-8	BLU-GRY	
25	RIGHT ARCH FLASHER	F109	J102-8	RED-WHT	Q67	J112-9	BLK-BRN	#89
26	LEFT MARTIAN FLASHER	F109	J102-8	RED-WHT	Q68	J112-10	BLK-RED	#89
27	RIGHT MARTIAN FLASHER	F109	J102-8	RED-WHT	Q69	J112-19	BLK-ORG	#89
28	ATTACK MARS FLASHER	F109	J102-8	RED-WHT	Q70	J112-20	BLK-YEL	#906
	<b>Flipper Circuits</b>							
33	LOW RIGHT FLIPPER PWR				Q35	J112-1	YEL-GRN	
34	LOW RIGHT FLIPPER HOLD	F104	J103-1	RED-GRN	Q36	J112-2	ORG-GRN	FL1-11629
35	LOW LEFT FLIPPER PWR				Q37	J112-3	YEL-BLU	
36	LOW LEFT FLIPPER HOLD	F105	J103-2	RED-BLU	Q38	J112-4	ORG-BLU	FL1-11629
37	LOCK DIVERTER POWER				Q39	J112-5	YEL-VIO	
38	LOCK DIVERTER HOLD	F106	J103-3	RED-VIO	Q40	J112-6	ORG-VIO	FL1-22241
39	UP/DOWN RAMP POWER				Q41	J112-7	YEL-GRY	
40	UP/DOWN RAMP HOLD	F107	J103-4	RED-GRY	Q42	J112-8	ORG-GRY	FL1-11753



# **SECTION THREE**

## **GAME WIRING AND SCHEMATICS**

**Schematics for standard PINBALL 2000 PC boards that are located in the cabinet and backbox are found in the PINBALL 2000 Schematic Manual. Schematics for PC boards attached to the playfield are found in this section.**

# LAMP MATRIX A

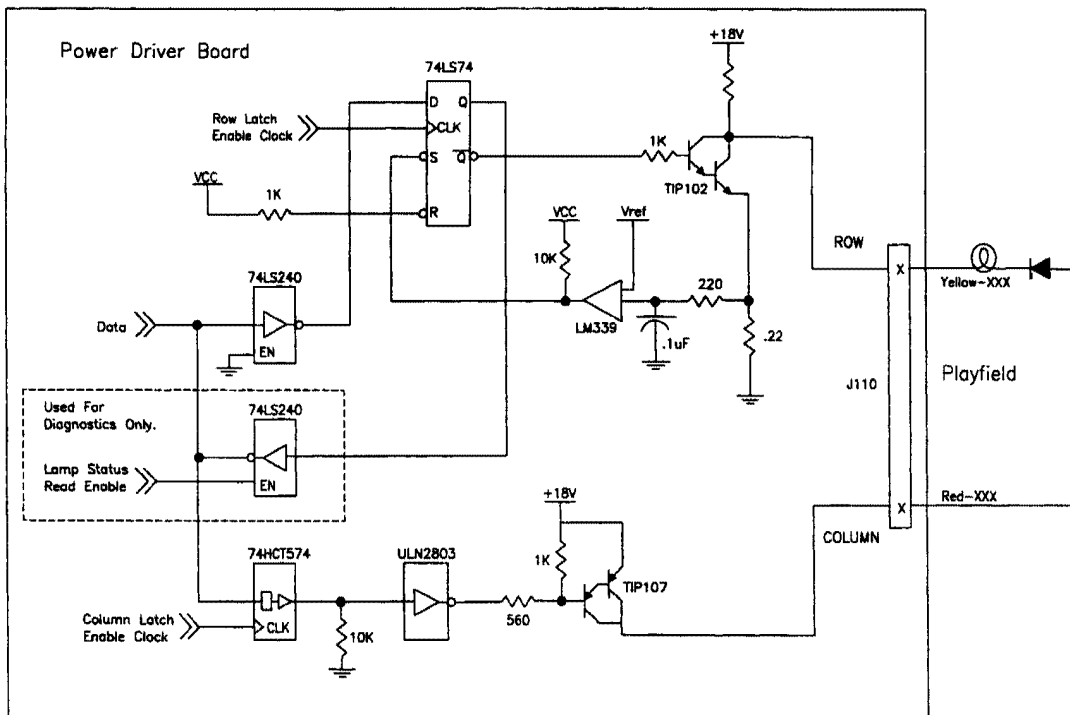
COLUMN	1A YEL-BRN J108-9 Q5	2A YEL-RED J108-10 Q9	3A YEL-ORG J108-11 Q13	4A YEL-BLK J108-12 Q17	5A YEL-GRN J108-13 Q21	6A YEL-BLU J108-14 Q25	7A YEL-VIO J108-15 Q29	8A YEL-GRY J108-16 Q33
ROW								
1A BRN-BLK J108-1 Q3	NOT USED 11A	TICKETS LOW 21A	NOT USED 31A	RIGHT POPPER ARROW 41A	MULTIBALL 51A	SHOOTER LANE 9 (TOP) 61A	LEFT SIDE 1 (BOTTOM) 71A	RIGHT SLINGSHOT (BOTTOM) 81A
2A BRN-RED J108-2 Q7	NOT USED 12A	NOT USED 22A	NOT USED 32A	EXTRA BALL 42A	CAPTURE 2 52A	UNDER RIGHT RAMP (LOW) 62A	LEFT SIDE 2 72A	RIGHT SLINGSHOT (SAUCER) 82A
3A BRN-ORG J108-3 Q11	START BUTTON 13A	LAUNCH BUTTON 23A	NOT USED 33A	MARTIAN ATTACK 43A	CAPTURE 1 53A	UNDER RIGHT RAMP (HIGH) 63A	LEFT SIDE 3 73A	RIGHT RETURN LANE (RIGHT) 83A
4A BRN-YEL J108-4 Q15	NOT USED 14A	COIN DOOR ILLUMINA. 24A	NOT USED 34A	STROKE OF LUCK 44A	CAPTURE ZONE ACTIVE 54A	UPPER RT. CORNER (LOW) 64A	LEFT SIDE 4 (TOP) 74A	RIGHT RETURN LANE (LEFT) 84A
5A BRN-GRN J108-5 Q19	RIGHT TOP LANE 15A	MOTHERSHIP MULTIBALL (RIGHT) 25A	LEFT DRAIN TO TROUGH 35A	LEFT SIDE SPOTLIGHT 45A	SHOOT AGAIN 55A	RIGHT ARCH (RIGHT) 65A	UNDER LEFT RAMP (BOTTOM) 75A	LEFT RETURN LANE (RIGHT) 85A
6A BRN-BLU J108-6 Q23	LEFT TOP LANE 16A	MOTHERSHIP MULTIBALL (LEFT) 26A	RIGHT DRAIN TO TROUGH 36A	CENTER ARROW 46A	BEHIND CENTER TARGETS 56A	RIGHT ARCH (LEFT) 66A	UNDER LEFT RAMP (TOP) 76A	LEFT RETURN LANE (LEFT) 86A
7A BRN-VIO J108-7 Q27	MARTIAN TARGET 4 (CENTER) 17A	LEFT RETURN LANE 27A	RIGHT RETURN LANE 37A	RIGHT MARTIAN (HIGH) 47A	UPPER RT. CORNER (MIDDLE) 57A	LEFT ARCH (RIGHT) 67A	BETWEEN L/B JETS 77A	LEFT SLINGSHOT (SAUCER) 87A
8A BRN-GRY J108-8 Q31	CENTER LOOP ARROW 18A	LEFT OUTLANE 28A	RIGHT OUTLANE 38A	RIGHT MARTIAN (LOW) 48A	NOT USED 58A	LEFT ARCH (LEFT) 68A	UPPER LEFT CORNER 78A	LEFT SLINGSHOT (BOTTOM) 88A

J1XX = Power Driver Board

# LAMP MATRIX B

COLUMN	1B YEL-BRN J107-10 Q6	2B YEL-RED J107-11 Q10	3B YEL-ORG J107-12 Q14	4B YEL-BLK J107-13 Q18	5B YEL-GRN J107-14 Q22	6B YEL-BLU J107-15 Q26	7B YEL-VIO J107-16 Q30	8B YEL-GRY J107-17 Q34
1B RED-BRN J107-1 Q4	SECRET WEAPON 11B	BIG-O-BEAM 21B	MARS KNEADS WOMEN 31B	MARTIAN HARRY HOUR 41B	RIGHT LOOP ARROW 51B	MARTIAN TARGET 5 (RT. TOP) 61B	BOTTOM JET BUMPER 71B	SHOOTER LANE 1 (BOTTOM) 81B
2B RED-BLK J107-2 Q8	TOWER STRUGGLE 12B	RIGHT SAUCER BEAM (LEFT) 22B	RIGHT SAUCER BEAM (RT) 32B	ALIEN ABDUCTION 42B	RIGHT LOOP CIRCLE 52B	MARTIAN TARGET 6 (RT. MID.) 62B	NOT USED 72B	SHOOTER LANE 2 82B
3B RED-ORG J107-3 Q12	CENTER SAUCER BEAM (LEFT) 13B	WEAPONS 23B	SAUCER RIM 9 (RIGHT) 33B	LEFT SAUCER BEAM (LEFT) 43B	RIGHT RAMP ARROW 53B	MARTIAN TARGET 7 (RT. BOT.) 63B	LEFT JET BUMPER 73B	SHOOTER LANE 3 83B
4B RED-YEL J107-4 Q16	QUESTION MARK 14B	SAUCER 24B	SAUCER RIM 8 34B	SAUCER RIM 1 (LEFT) 44B	RIGHT RAMP CIRCLE 54B	MARTIAN TARGET 3 (LEFT TOP) 64B	LEFT OF LEFT TOP LANE 74B	SHOOTER LANE 4 84B
5B RED-GRN J107-5 Q20	CENTER SAUCER BEAM (RT.) 15B	FUEL 25B	SAUCER RIM 7 35B	SAUCER RIM 2 45B	LEFT LOOP ARROW 55B	MARTIAN TARGET 2 (LEFT MID.) 65B	BETWEEN L/R TOP LANES 75B	SHOOTER LANE 5 85B
6B RED-BLU J107-6 Q24	DRIVE-IN DEMOLITION 16B	LEFT SAUCER BEAM (RT.) 26B	SAUCER RIM 6 36B	SAUCER RIM 3 46B	LEFT RAMP ARROW 56B	MARTIAN TARGET 1 (LEFT BOT.) 66B	RIGHT OF RIGHT TOP LANE 76B	SHOOTER LANE 6 86B
7B RED-VIO J107-7 Q28	PARIS IN PERIL 17B	CENTER SAUCER BEAM (CNTR) 27B	SAUCER RIM 5 37B	SAUCER RIM 4 47B	LEFT LOOP CIRCLE 57B	RIGHT MARTIAN EYE 67B	TOP OF CENTER LOOP 77B	SHOOTER LANE 7 87B
8B RED-GRY J107-8 Q32	LEFT SLINGSHOT SPOTLIGHT 18B	RIGHT SLINGSHOT SPOTLIGHT 28B	NOT USED 38B	NOT USED 48B	LEFT RAMP CIRCLE 58B	LEFT MARTIAN EYE 68B	UPPER RT. CORNER (HIGH) 78B	SHOOTER LANE 8 88B

## LAMP MATRIX CIRCUIT



## SWITCH MATRIX

COLUMN	1 GRN-BRN J116-1 U45-18	2 GRN-RED J116-2 U45-17	3 GRN-ORG J116-3 U45-16	4 GRN-WHT J116-4 U45-15	5 GRN-BLK J116-5 U45-14	6 GRN-BLU J116-6 U45-13	7 GRN-VIO J116-7 U45-12	8 GRN-GRY J116-8 U45-11
1 WHT-BRN J116-12 U51-7	RIGHT RAMP ENTRANCE 11	NOT USED 21	CENTER LOOP REED (BOTTOM) 31	TROUGH JAM 41	RIGHT LOCKUP 1 51	LEFT SLINGSHOT 61	MARTIAN TARGET 3 (LEFT TOP) 71	NOT USED 81
2 WHT-RED J116-13 U51-5	LEFT RAMP EXIT 12	NOT USED 22	CENTER LOOP REED (TOP) 32	TROUGH BALL 1 42	LEFT RAMP ENTRANCE 52	RIGHT SLINGSHOT 62	MARTIAN TARGET 2 (LEFT MID.) 72	NOT USED 82
3 WHT-ORG J116-14 U51-9	START BUTTON 13	LAUNCH BUTTON 23	CENTER TARGET 4 33	TROUGH BALL 2 43	NOT USED 53	LEFT JET BUMPER 63	MARTIAN TARGET 1 (LEFT BOT.) 73	NOT USED 83
4 WHT-YEL J116-15 U51-11	NOT USED 14	NOT USED 24	CENTER TARGET 3 34	TROUGH BALL 3 44	NOT USED 54	RIGHT JET BUMPER 64	CENTER LOOP ROLLOVER 74	NOT USED 84
5 WHT-GRN J116-16 U57-7	DROP TARGET DOWN 15	LEFT LOOP (LOW) 25	CENTER TARGET 2 35	TROUGH BALL 4 45	NOT USED 55	BOTTOM JET BUMPER 65	CENTER DEFLECTOR PANEL 75	MARTIAN TARGET 7 (RT. BOT.) 85
6 WHT-BLU J116-17 U57-5	LEFT OUTLANE 16	LEFT RETURN LANE 26	CENTER TARGET 1 36	RIGHT POPPER 46	NOT USED 56	NOT USED 66	RIGHT TOP LANE 76	MARTIAN TARGET 6 (RT. MID.) 86
7 WHT-VIO J116-18 U57-9	RIGHT RETURN LANE 17	RIGHT OUTLANE 27	MARTIAN TARGET 4 (CENTER) 37	JET EXT 47	NOT USED 57	RIGHT LOOP (LOW) 67	LEFT TOP LANE 77	MARTIAN TARGET 5 (RT. TOP) 87
8 WHT-GRY J116-19 U57-11	SHOOTER LANE 18	RIGHT RAMP EXIT 28	UP/DOWN RAMP UP 38	NOT USED 48	NOT USED 58	RIGHT LOOP (HIGH) 68	LEFT LOOP (HIGH) 78	NOT USED 88

= OPTO, TYPICALLY CLOSED

## COIN SLOT SWITCHES

DIRECT GROUND	ORN-BRN J114-1 U43-7	ORG-RED J114-2 U43-5	ORG-BLK J114-3 U43-9	ORG-YEL J114-4 U43-11	ORG-GRN J114-5 U48-7	ORG-BLU J114-6 U48-5	ORG-VIO J114-8 U48-9	ORG-GRY J114-9 U48-11
BLACK J114-14	LEFT COIN SLOT D1	CENTER COIN SLOT D2	RIGHT COIN SLOT D3	4 <sup>TH</sup> COIN OPTION D4	NOT USED D5	NOT USED D6	NOT USED D7	NOT USED D8

## DIAGNOSTIC SWITCHES

DIRECT GROUND	GRY-BLK J114-10 U50-7	GRY-ORG J114-11 U50-5	GRY-RED J114-12 U50-9	GRY-BRN J114-13 U50-11
BLACK J114-14	'ESCAPE' BUTTON D9	'DOWN' BUTTON D10	'UP' BUTTON D11	'ENTER' BUTTON D12

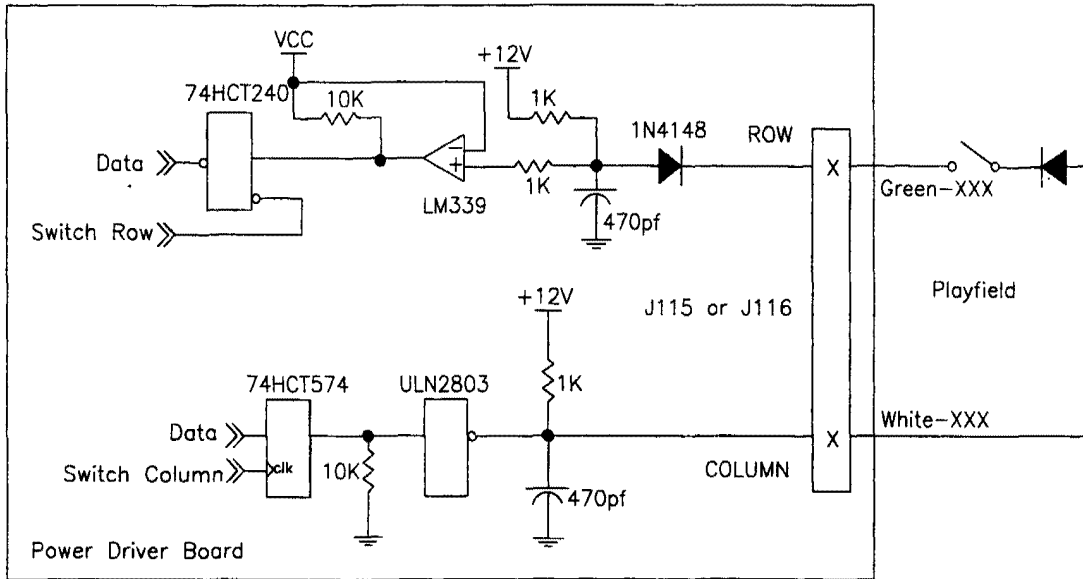
## PLAYFIELD FLIPPER SWITCHES (E.O.S.)

DIRECT GROUND	BLK-GRN J115-9 U56-7	BLK-BLU J115-10 U56-5	BLK-VIO J115-20 U56-9	BLK-GRY J115-21 U56-11
BLACK J115-22	LOWER RIGHT FLIPPER E.O.S. D13	LOWER LEFT FLIPPER E.O.S. D14	NOT USED D15	NOT USED D16

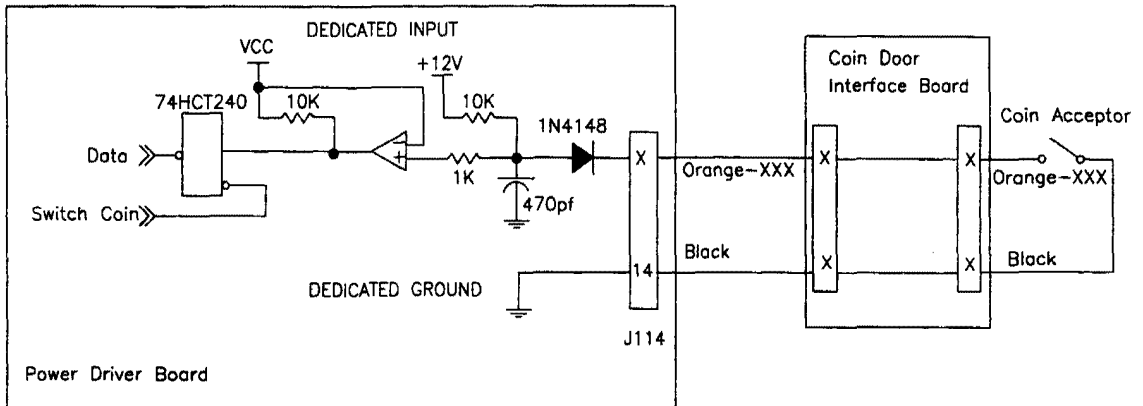
## CABINET FLIPPER SWITCHES

DIRECT GROUND	BLK-BRN J113-1 U49-7	BLK-RED J113-2 U49-5	BLK-ORG J113-3 U49-9	BLK-YEL J113-4 U49-11	BLK-GRN J113-6 U55-7	BLK-BLU J113-7 U55-5	BLK-VIO J113-8 U55-9	BLK-GRY J113-9 U55-11
BLACK J113-10	SLAM TILT D17	COIN DOOR CLOSED D18	PLUMB BOB TILT D19	NOT USED D20	RIGHT FLIPPER BUTTON D21	LEFT FLIPPER BUTTON D22	RIGHT ACTION BUTTON D23	LEFT ACTION BUTTON D24

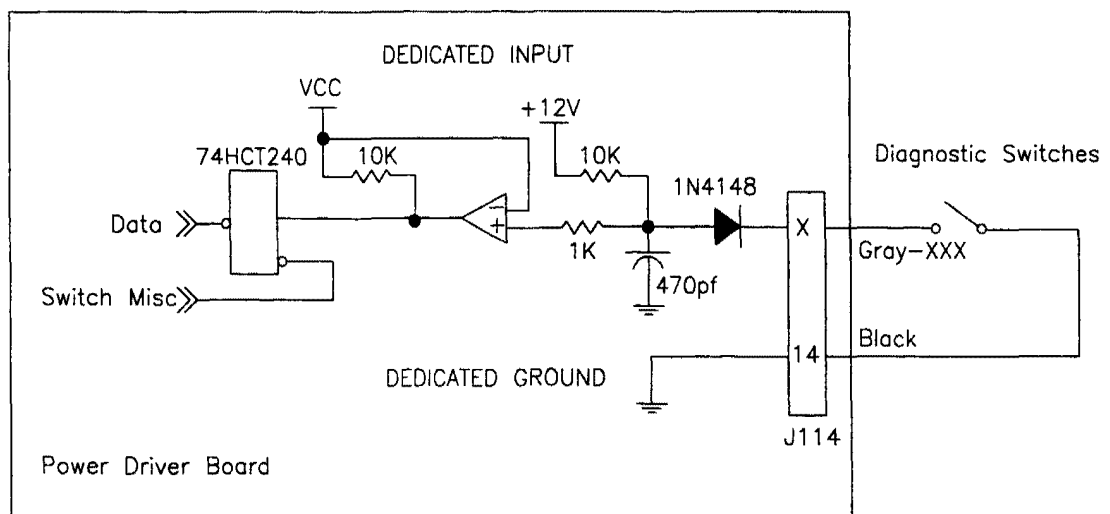
### SWITCH MATRIX CIRCUIT



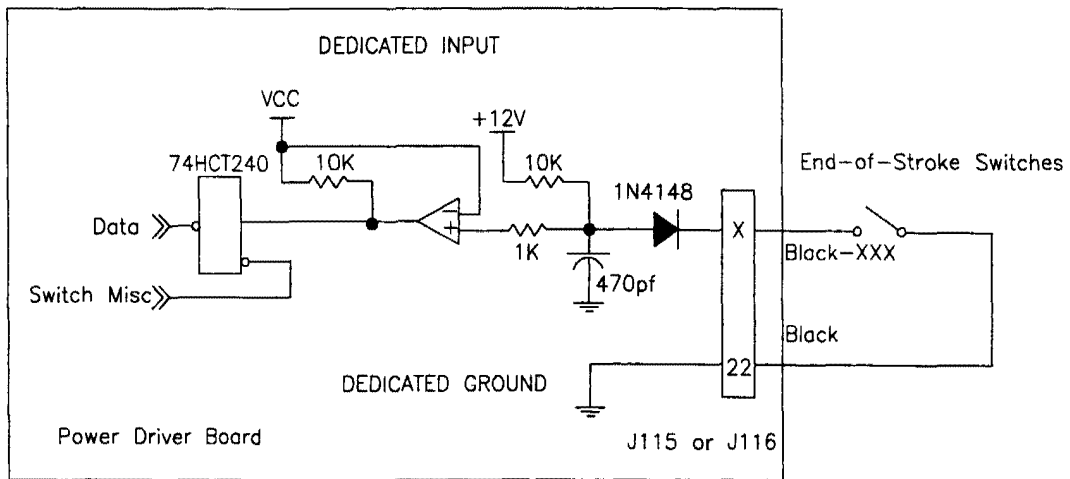
### COIN SLOT SWITCH CIRCUIT



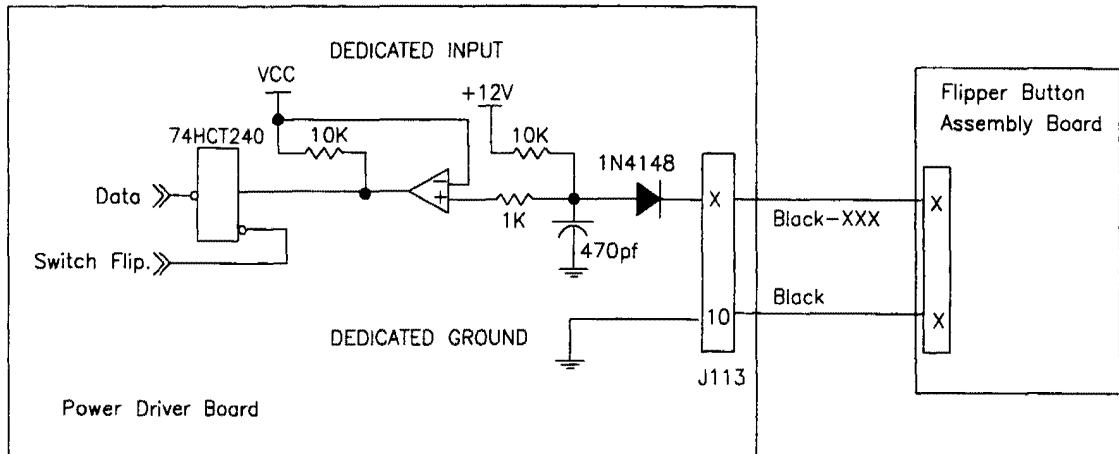
### DIAGNOSTIC SWITCH CIRCUIT



### PLAYFIELD FLIPPER SWITCH (E.O.S.) CIRCUIT



### CABINET FLIPPER SWITCH CIRCUIT

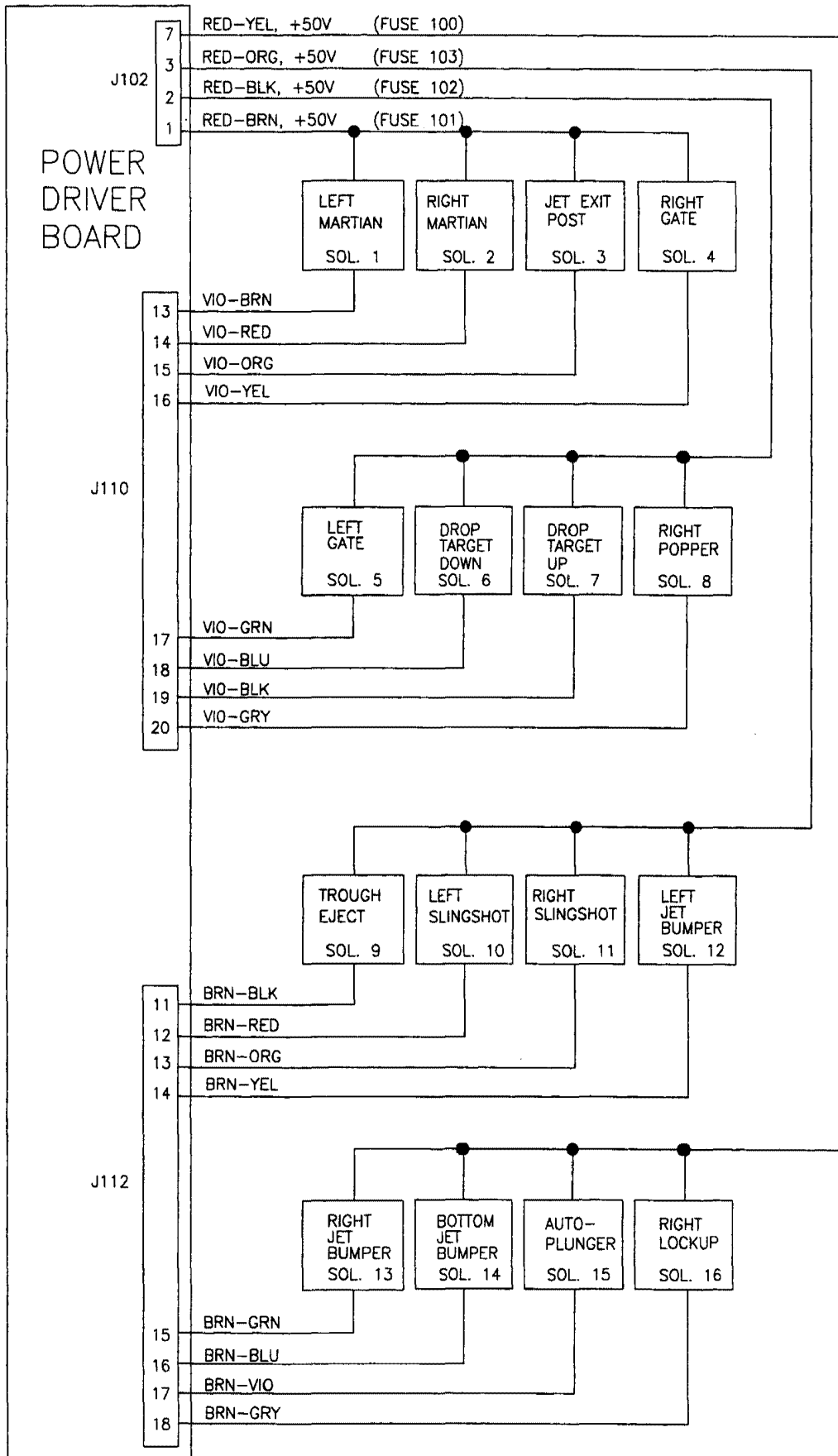


## SOLENOID TABLE

Sol No.	Solenoid Function	Fuse	Power to Playfield	Power Wire Color	Drive Transistor	Drive to Playfield	Drive Wire Color	Solenoid Part Number or Flasher Type
01	LEFT MARTIAN	F101	J102-1	RED-BRN	Q59	J110-13	VIO-BRN	AE1-26-1500
02	RIGHT MARTIAN	F101	J102-1	RED-BRN	Q60	J110-14	VIO-RED	AE1-26-1500
03	JET EXIT POST	F101	J102-1	RED-BRN	Q61	J110-15	VIO-ORG	AE1-26-1500
04	RIGHT GATE	F101	J102-1	RED-BRN	Q62	J110-16	VIO-YEL	A-14406
05	LEFT GATE	F102	J102-2	RED-BLK	Q63	J110-17	VIO-GRN	A-14406
06	DROP TARGET DOWN	F102	J102-2	RED-BLK	Q64	J110-18	VIO-BLU	SM1-26-600
07	DROP TARGET UP	F102	J102-2	RED-BLK	Q65	J110-19	VIO-BLK	AE1-26-1200
08	RIGHT POPPER	F102	J102-2	RED-BLK	Q66	J110-20	VIO-GRY	AE1-25-1000
09	TROUGH EJECT	F103	J102-3	RED-ORG	Q51	J112-11	BRN-BLK	AE1-26-1500
10	LEFT SLINGSHOT	F103	J102-3	RED-ORG	Q52	J112-12	BRN-RED	AE1-26-1200
11	RIGHT SLINGSHOT	F103	J102-3	RED-ORG	Q53	J112-13	BRN-ORG	AE1-26-1200
12	LEFT JET BUMPER	F103	J102-3	RED-ORG	Q54	J112-14	BRN-YEL	AE1-26-1200
13	RIGHT JET BUMPER	F100	J102-7	RED-YEL	Q55	J112-15	BRN-GRN	AE1-26-1200
14	BOTTOM JET BUMPER	F100	J102-7	RED-YEL	Q56	J112-16	BRN-BLU	AE1-26-1200
15	AUTO PLUNGER	F100	J102-7	RED-YEL	Q57	J112-17	BRN-VIO	AE1-23-800
16	RIGHT LOCKUP	F100	J102-7	RED-YEL	Q58	J112-18	BRN-GRY	AE1-23-800
17	CENTER ARROW FLASHER	F109	J102-8	RED-WHT	Q43	J110-1	BLU-BRN	#906
18	NOT USED	F109			Q44	J110-2	BLU-RED	
19	NOT USED	F109			Q45	J110-3	BLU-ORG	
20	NOT USED	F109			Q46	J110-4	BLU-YEL	
21	NOT USED	F109			Q47	J110-5	BLU-GRN	
22	RIGHT POPPER FLASHER	F109	J102-8	RED-WHT	Q48	J110-6	BLU-BLK	#906
23	LEFT ARCH FLASHER	F109	J102-8	RED-WHT	Q49	J110-7	BLU-VIO	#89
24	NOT USED	F109			Q50	J110-8	BLU-GRY	
25	RIGHT ARCH FLASHER	F109	J102-8	RED-WHT	Q67	J112-9	BLK-BRN	#89
26	LEFT MARTIAN FLASHER	F109	J102-8	RED-WHT	Q68	J112-10	BLK-RED	#89
27	RIGHT MARTIAN FLASHER	F109	J102-8	RED-WHT	Q69	J112-19	BLK-ORG	#89
28	ATTACK MARS FLASHER	F109	J102-8	RED-WHT	Q70	J112-20	BLK-YEL	#906
	<b>Flipper Circuits</b>							
33	LOW RIGHT FLIPPER PWR				Q35	J112-1	YEL-GRN	
34	LOW RIGHT FLIPPER HOLD	F104	J103-1	RED-GRN	Q36	J112-2	ORG-GRN	FL1-11629
35	LOW LEFT FLIPPER PWR				Q37	J112-3	YEL-BLU	
36	LOW LEFT FLIPPER HOLD	F105	J103-2	RED-BLU	Q38	J112-4	ORG-BLU	FL1-11629
37	LOCK DIVERter POWER				Q39	J112-5	YEL-VIO	
38	LOCK DIVERter HOLD	F106	J103-3	RED-VIO	Q40	J112-6	ORG-VIO	FL1-22241
39	UP/DOWN RAMP POWER				Q41	J112-7	YEL-GRY	
40	UP/DOWN RAMP HOLD	F107	J103-4	RED-GRY	Q42	J112-8	ORG-GRY	FL1-11753

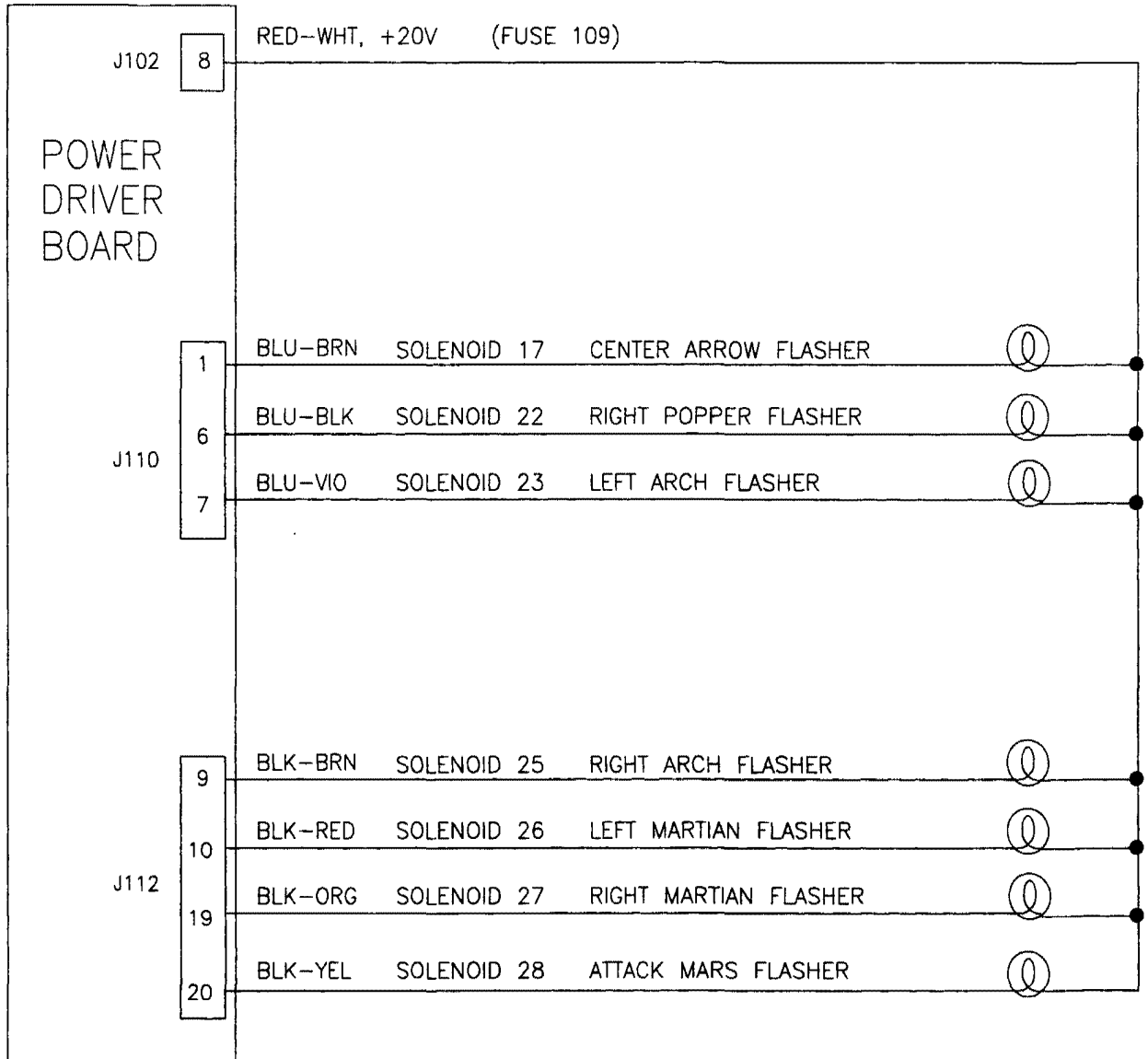
**COILS**

**SOLENOID WIRING**

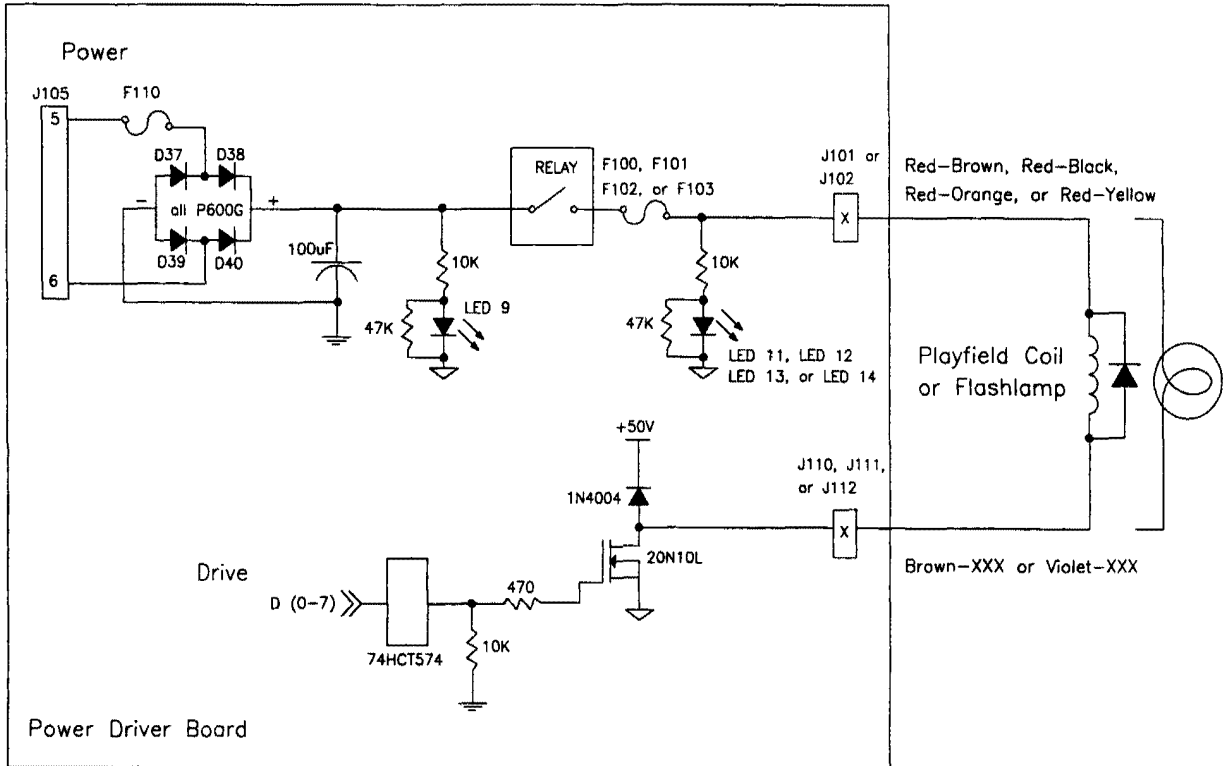




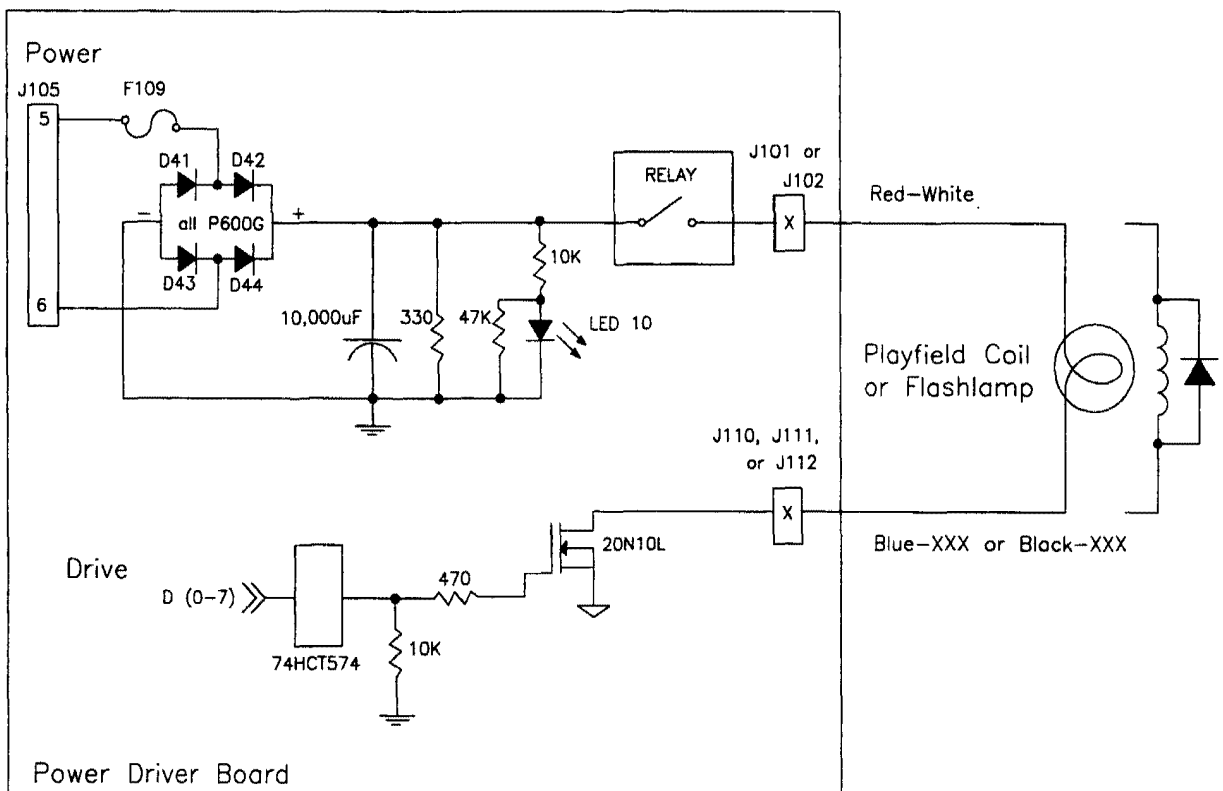
**FLASHLAMPS**



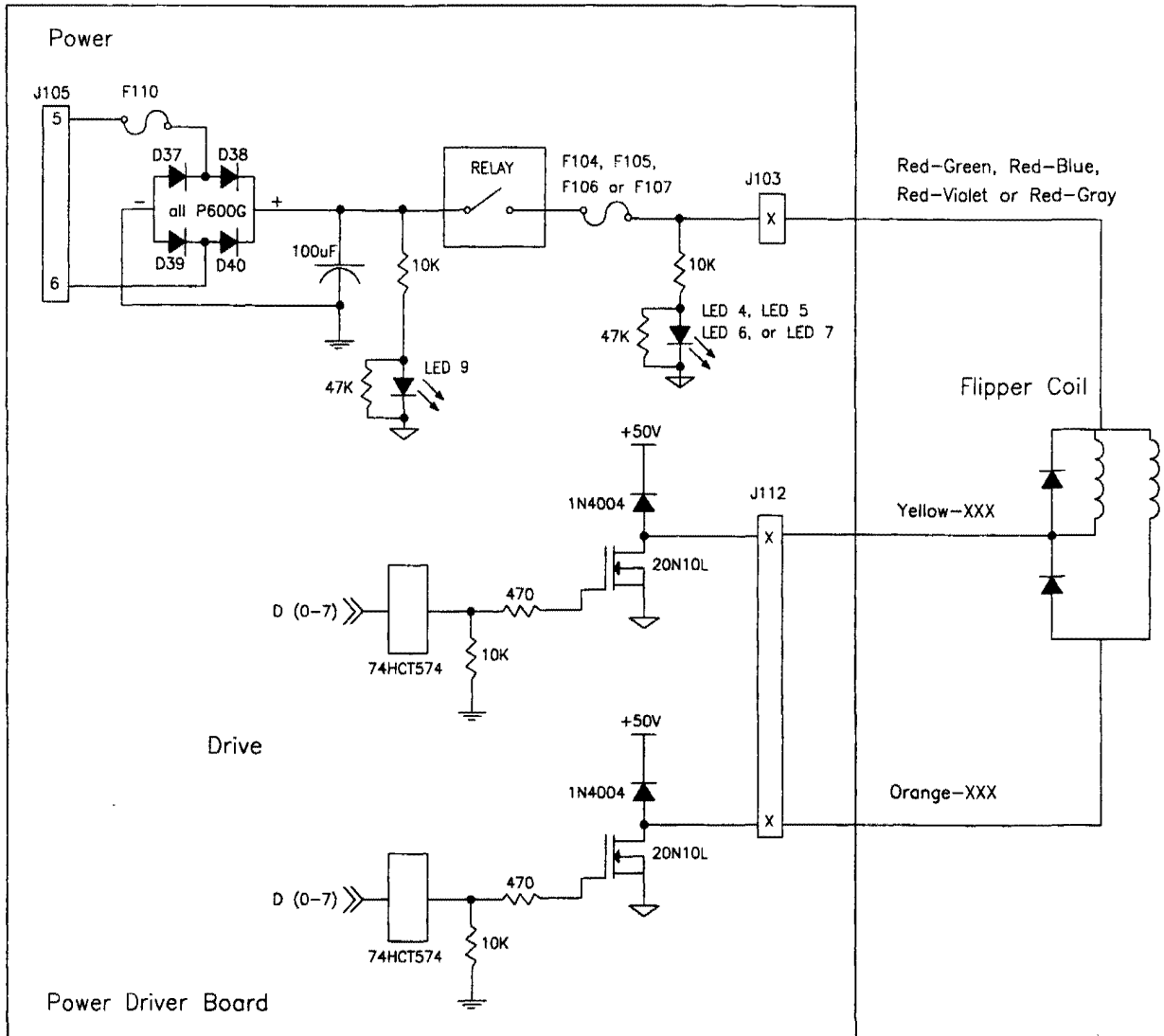
**CIRCUIT for SOLENOIDS 1 to 16**



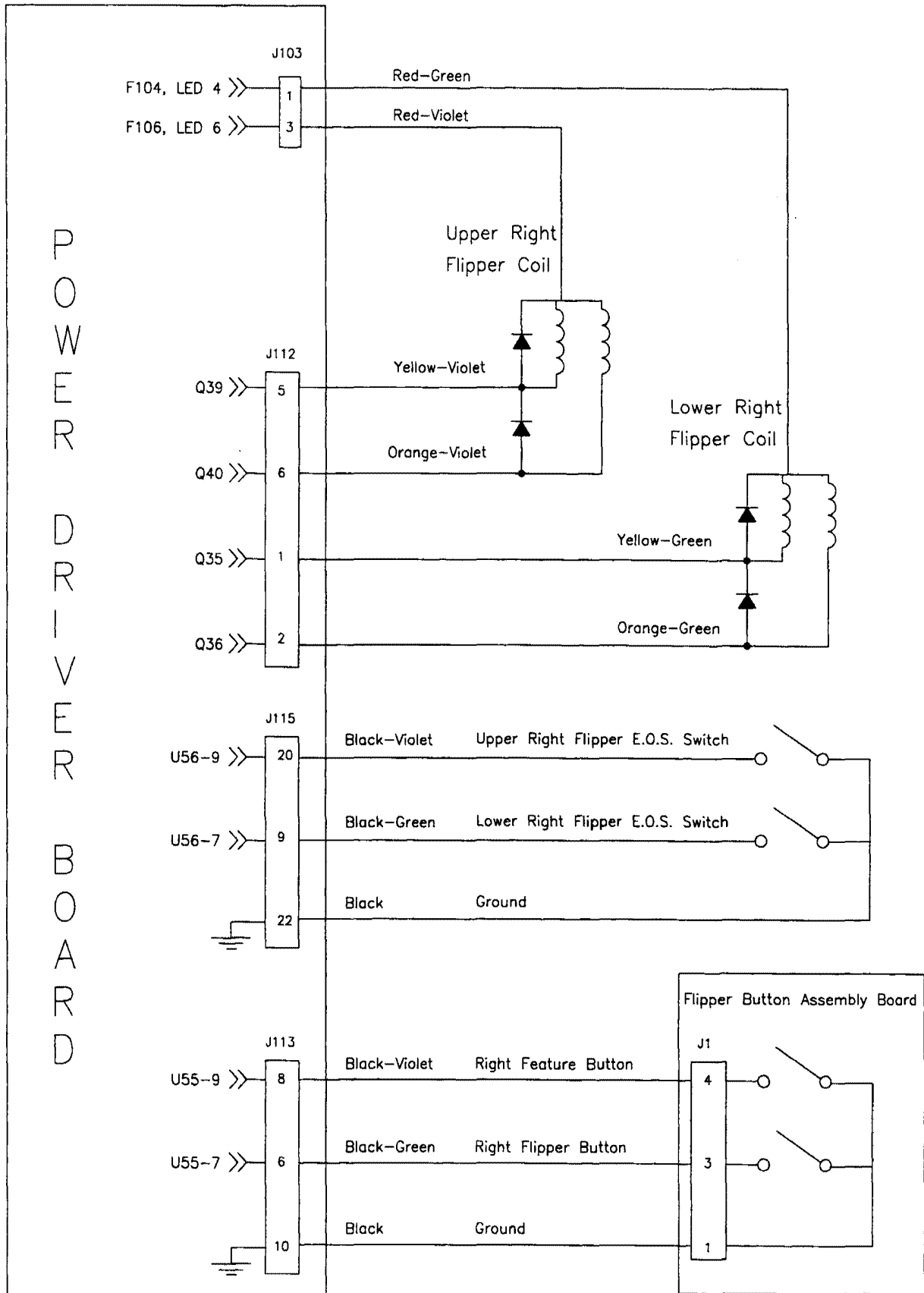
**CIRCUIT for SOLENOIDS 17 to 28**



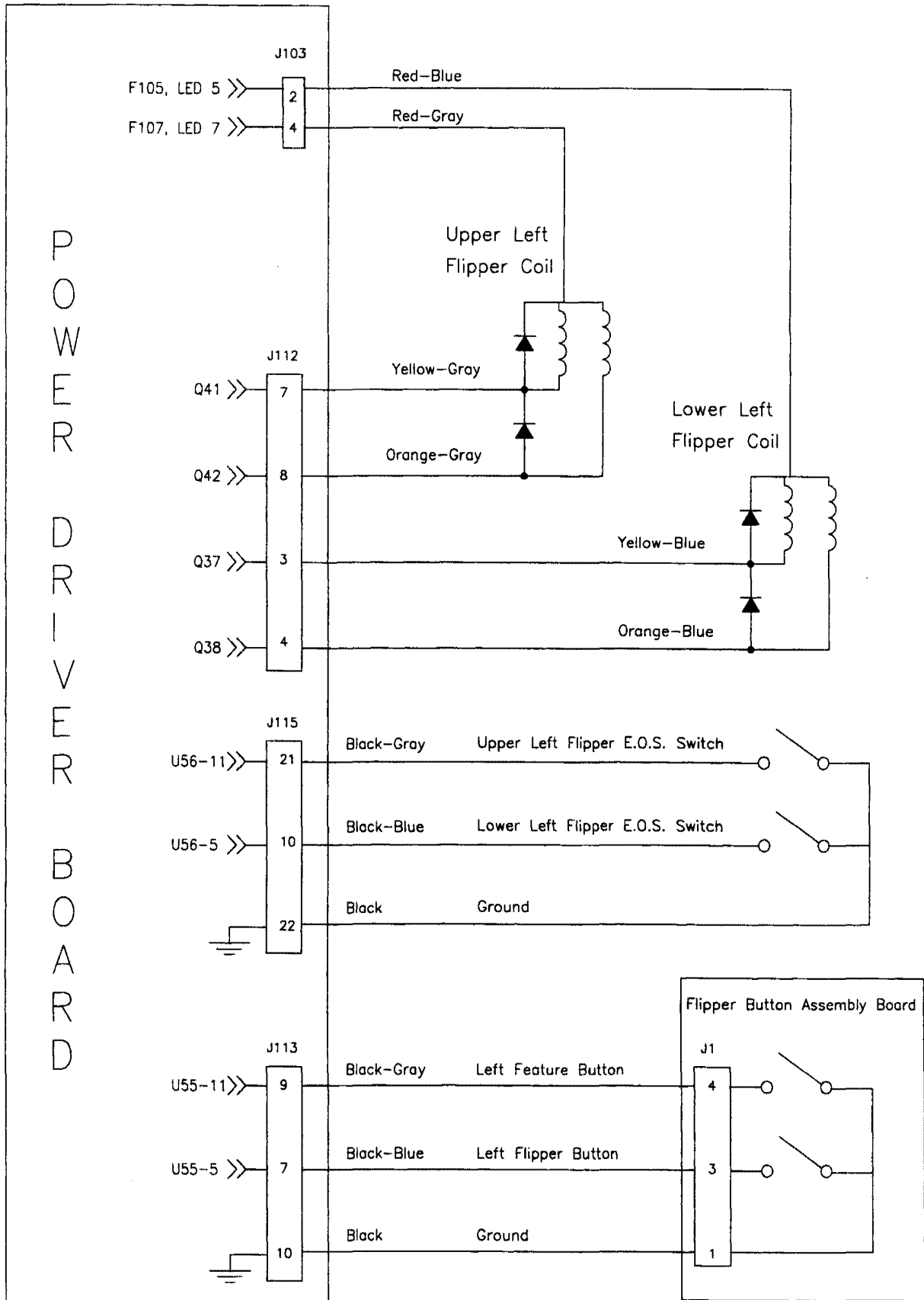
# FLIPPER COIL CIRCUIT



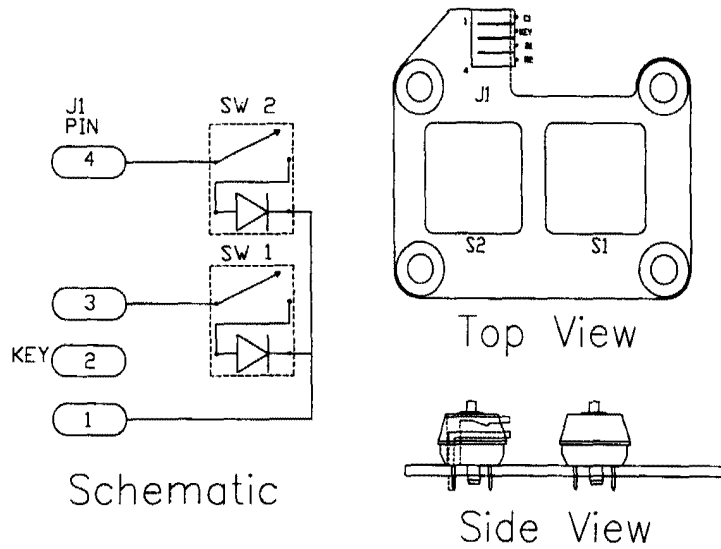
# UPPER AND LOWER RIGHT FLIPPER CIRCUITS



# UPPER AND LOWER LEFT FLIPPER CIRCUITS



## 2 SWITCH FLIPPER BUTTON ASSEMBLY 04-12612



### Left Side Flipper

J1-1 Black, Ground from Power Driver Board at J113-10

J1-2 Key

J1-3 Black-Blue, Flipper Button from Power Driver Board at J113-7

J1-4 Black-Gray, Feature Button from Power Driver Board at J113-9

### Right Side Flipper

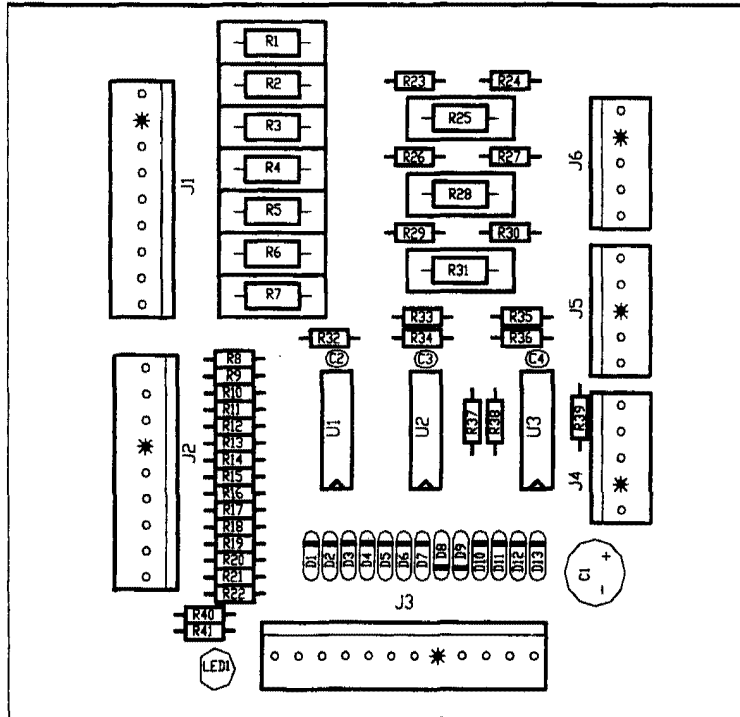
J1-1 Black, Ground from Power Driver Board at J113-10

J1-2 Key

J1-3 Black-Green, Flipper Button from Power Driver Board at J113-6

J1-4 Black-Violet, Feature Button from Power Driver Board at J113-8

## 10-Opto Switch Board Assembly A-18159.1



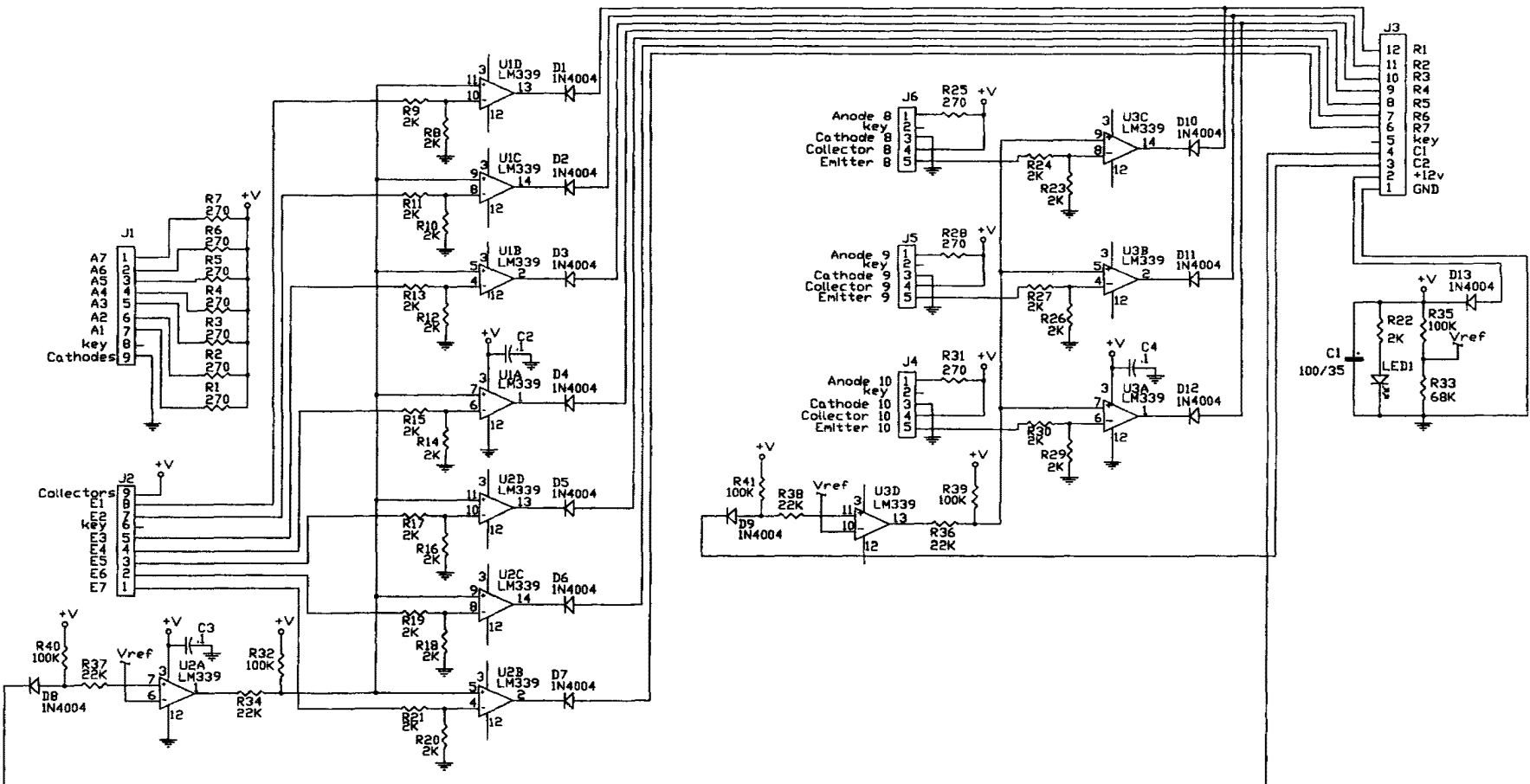
**J1-1** GRY-VIO To switch #47 LED board  
**J1-2** GRY-BLU To switch #46 LED board  
**J1-3** GRY-GRN To switch #45 LED board  
**J1-4** GRY-BLK To switch #44 LED board  
**J1-5** GRY-ORG To switch #43 LED board  
**J1-6** GRY-RED To switch #42 LED board  
**J1-7** GRY-BRN To switch #41 LED board  
**J1-8** KEY  
**J1-9** BLK Ground to LED boards

**J2-1** ORG-VIO To switch #47 Photo Trans. board  
**J2-2** ORG-BLU To switch #46 Photo Trans. board  
**J2-3** ORG-GRN To switch #45 Photo Trans. board  
**J2-4** ORG-YEL To switch #44 Photo Trans. board  
**J2-5** ORG-BLK To switch #43 Photo Trans. board  
**J2-6** KEY  
**J2-7** ORG-RED To switch #42 Photo Trans. board  
**J2-8** ORG-BRN To switch #41 Photo Trans. board  
**J2-9** GRY-YEL +12V to Photo Trans. boards

**J3-1** BLK Ground from Power Driver board J116-22  
**J3-2** GRY-YEL +12V from Power Driver board J116-11  
**J3-3** GRN-BLK Switch Row 5 from Power Driver board J116-5  
**J3-4** GRN-WHT Switch Row 4 from Power Driver board J116-4  
**J3-5** KEY  
**J3-6** WHT-VIO Switch Column #7 from Power Driver board J116-18  
**J3-7** WHT-BLU Switch Column #6 from Power Driver board J116-17  
**J3-8** WHT-GRN Switch Column #5 from Power Driver board J116-16  
**J3-9** WHT-YEL Switch Column #4 from Power Driver board J116-15  
**J3-10** WHT-ORG Switch Column #3 from Power Driver board J116-14  
**J3-11** WHT-RED Switch Column #2 from Power Driver board J116-13  
**J3-12** WHT-BRN Switch Column #1 from Power Driver board J116-12

**J4** NOT USED

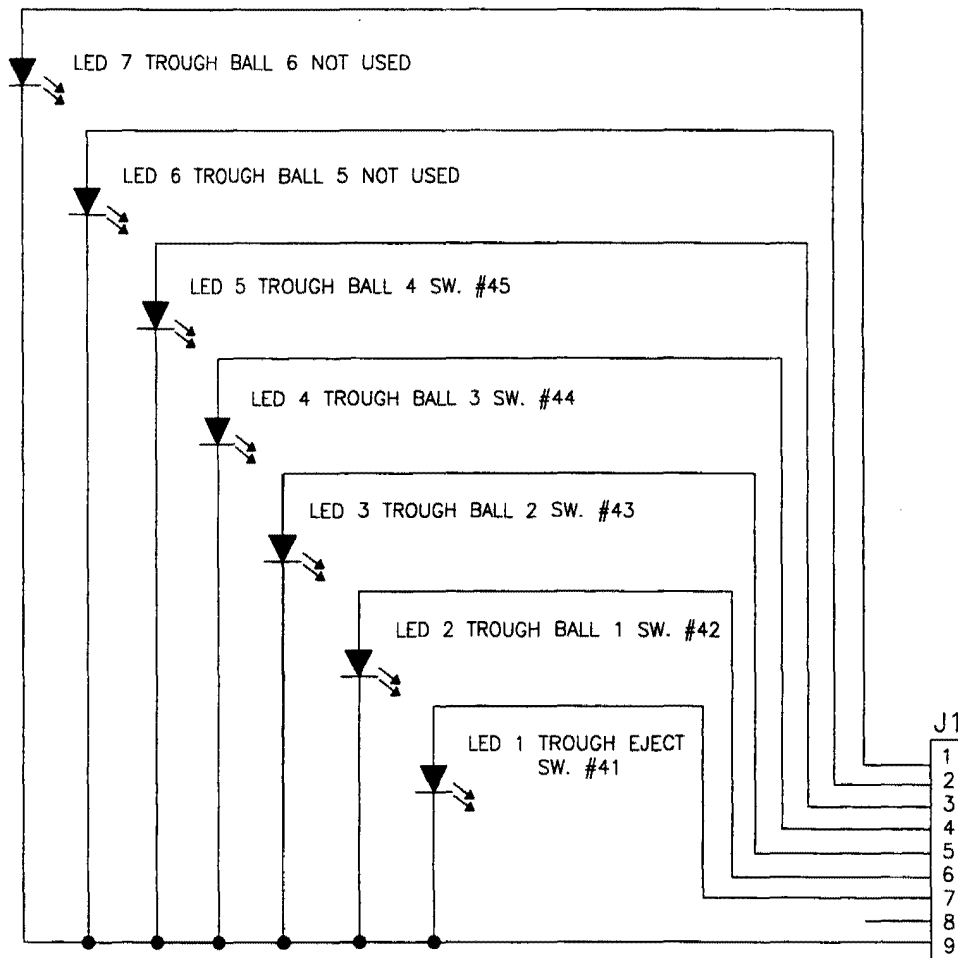
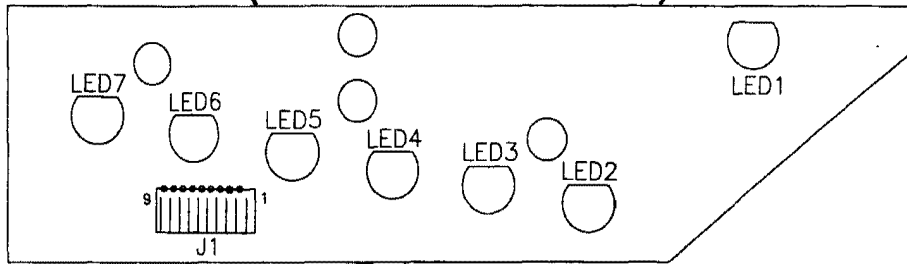
**J5-1** GRN-RED To switch #52 LED board  
**J5-2** BLK Ground to switch #52 LED board  
**J5-3** KEY  
**J5-4** GRY-YEL +12V to sw. #52 Photo Trans board  
**J5-5** WHT-RED To switch #52 Photo Trans. board  
**J6-1** GRN-BRN To switch #51 LED board  
**J6-2** KEY  
**J6-3** BLK Ground to switch #51 LED board  
**J6-4** GRY-YEL +12V to sw. #51 Photo Trans board  
**J6-5** WHT-BRN To switch #51 Photo Trans. board



10-Opto Switch Board Schematic  
A-18159.1

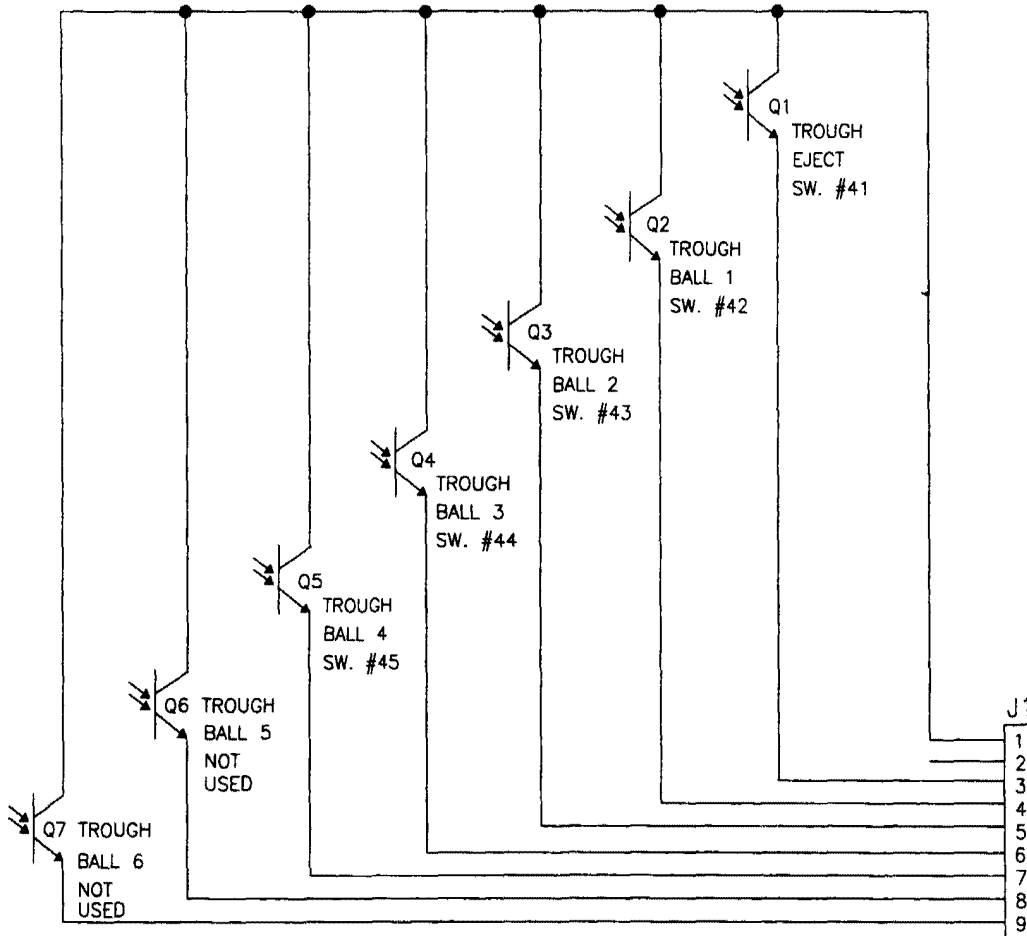
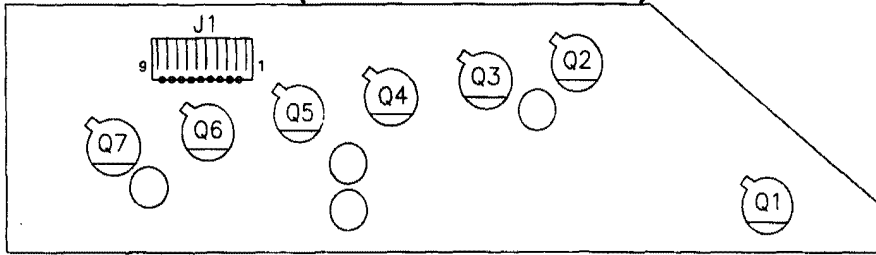


**Ball Trough Infrared LED Board Assembly  
A-18617-1  
(Transmitter - Green Board)**



- J1-1** N/C
- J1-2** N/C
- J1-3** GRY-GRN, For TROUGH BALL 4 switch #45 from 10-Opto Switch Board J1-3
- J1-4** GRY-BLK, For TROUGH BALL 3 switch #44 from 10-Opto Switch Board J1-4
- J1-5** GRY-ORG, For TROUGH BALL 2 switch #43 from 10-Opto Switch Board J1-5
- J1-6** GRY-RED, For TROUGH BALL 1 switch #42 from 10-Opto Switch Board J1-6
- J1-7** GRY-BRN, For TROUGH EJECT switch #41 from 10-Opto Switch Board J1-7
- J1-8** KEY
- J1-9** BLK, Ground from 10-Opto Switch Board J1-9

**Ball Trough Infrared Photo Transistor Board Assembly  
A-18618-1  
(Receiver - Blue Board)**



- J1-1** GRY-YEL, +12V from 10-Opto Switch Board J2-9
- J1-2** KEY
- J1-3** ORG-BRN, For TROUGH EJECT switch #41 from 10-Opto Switch Board J2-8
- J1-4** ORG-RED, For TROUGH BALL 1 switch #42 from 10-Opto Switch Board J2-7
- J1-5** ORG-BLK, For TROUGH BALL 2 switch #43 from 10-Opto Switch Board J2-5
- J1-6** ORG-YEL, For TROUGH BALL 3 switch #44 from 10-Opto Switch Board J2-4
- J1-7** ORG-GRN, For TROUGH BALL 4 switch #45 from 10-Opto Switch Board J2-3
- J1-8** N/C
- J1-9** N/C

## Wiring Diagram for the Ball Trough Assembly Opto Switches

This diagram shows the opto switches in the Ball Trough Assembly only. See page 3-21 for the individual playfield opto switches.

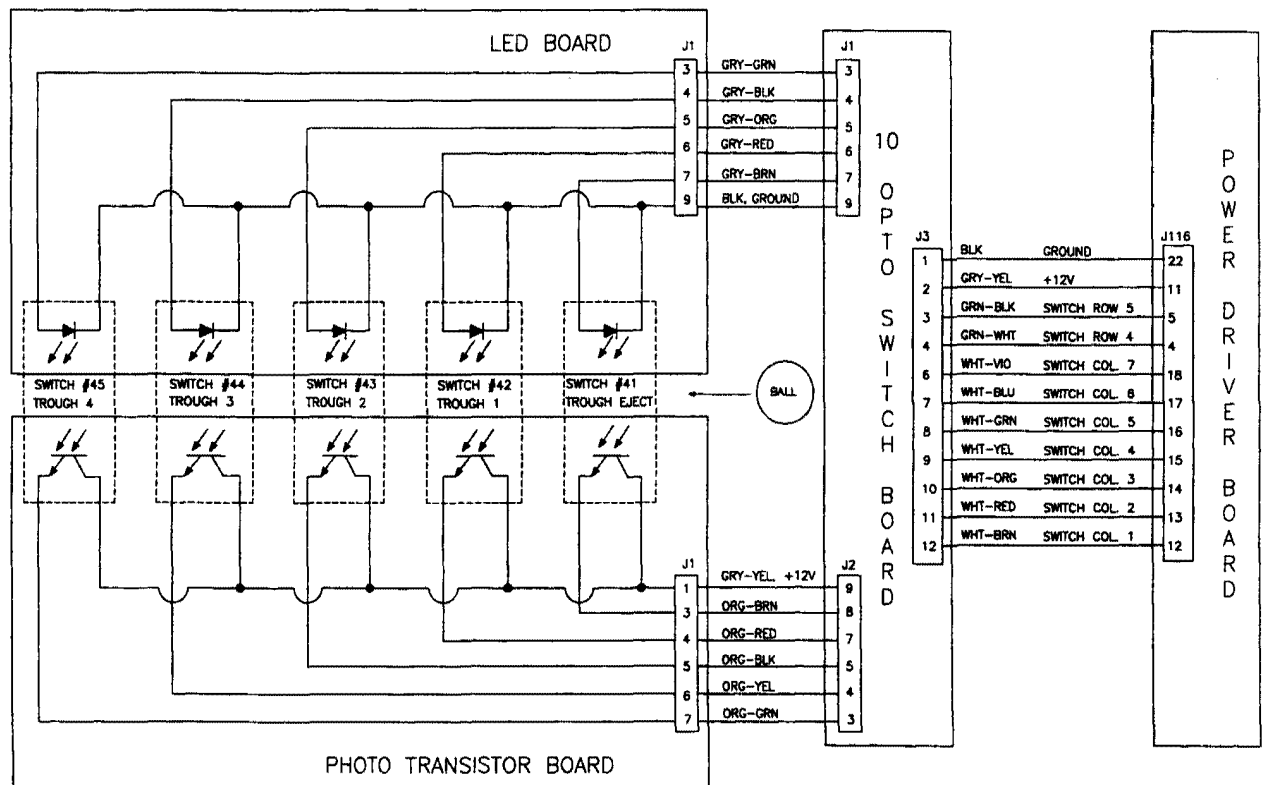
### The Ball Trough Assembly opto switches are:

- Switch #41 Trough Eject
- Switch #42 Trough Ball 1
- Switch #43 Trough Ball 2
- Switch #44 Trough Ball 3
- Switch #45 Trough Ball 4

The Ball Trough Assembly opto switches use a green Ball Trough LED board (P/N A-18617-1), and a blue Ball Trough Photo Transistor board (P/N A-18618-1).

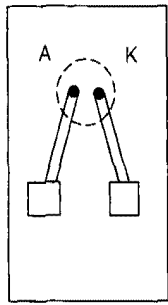
### OPTO SWITCH OPERATION:

The ball rolls between the Ball Trough LED board and the Ball Trough Photo Transistor board and breaks the beam. The broken beam 'makes' the switch.

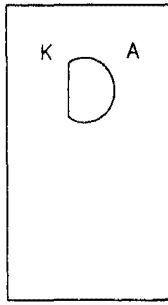


## Individual LED Board Assembly A-16908

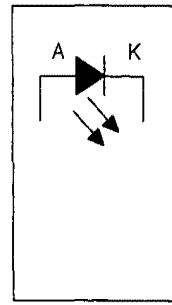
(Transmitter-Green Board)



solder side



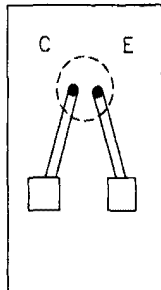
component side



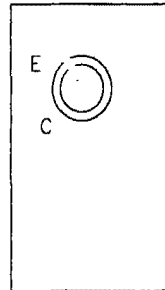
schematic

## Individual Photo Transistor Board Assembly A-16909

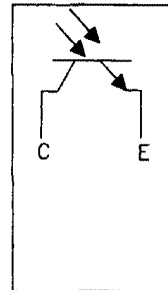
(Receiver-Blue Board)



solder side



component side



schematic

### Typical Circuit Diagram

LED BOARD  
Transmitter  
1.0-1.4 volts

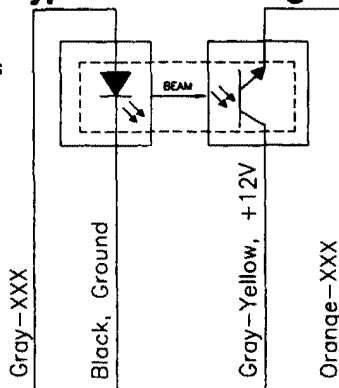
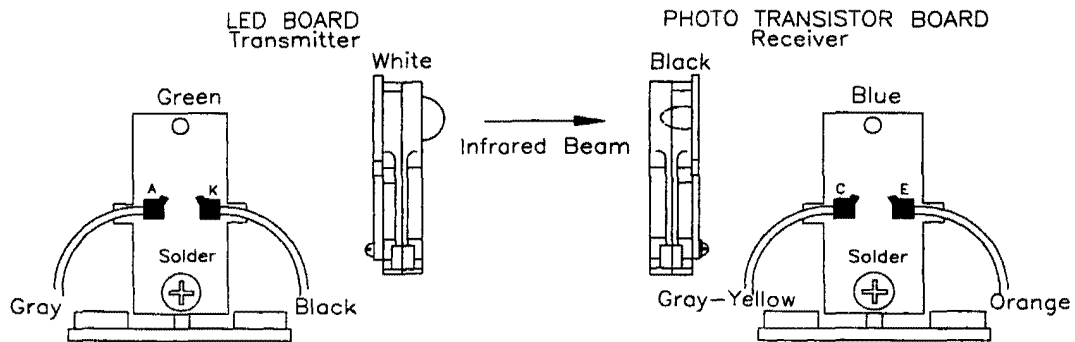


PHOTO TRANSISTOR BOARD  
Receiver  
0.1-0.7 volts unblocked  
11-13 volts blocked



## Wiring Diagram for Individual Playfield Opto Switches

This diagram shows the wiring for individual playfield opto switches only. See page 3-19 for the wiring diagram for the Ball Trough Assembly opto switches.

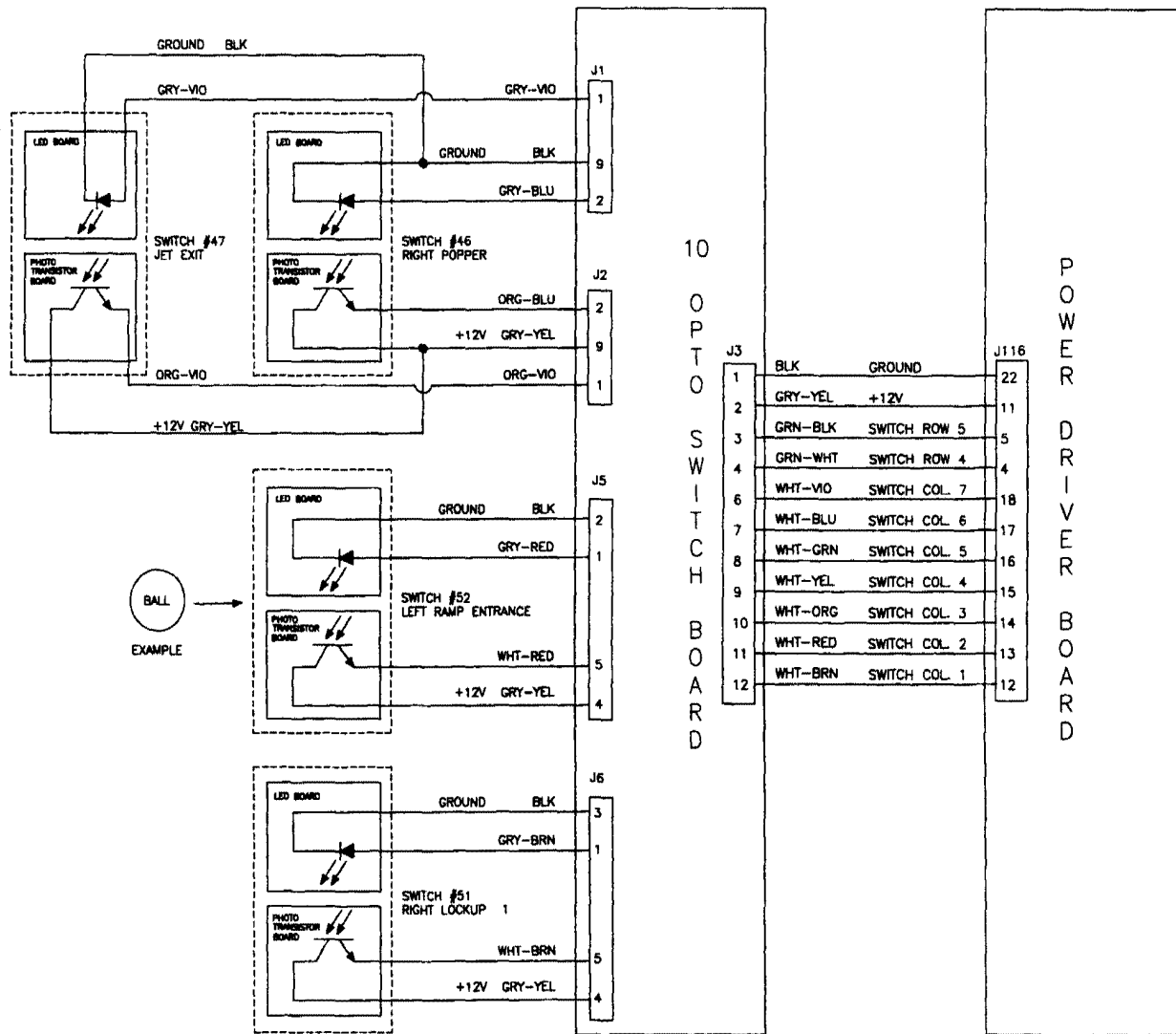
### The individual playfield opto switches are:

- Switch #46 Right Popper
- Switch #47 Jet Eject
- Switch #51 Right Lockup 1
- Switch #52 Left Ramp Entrance

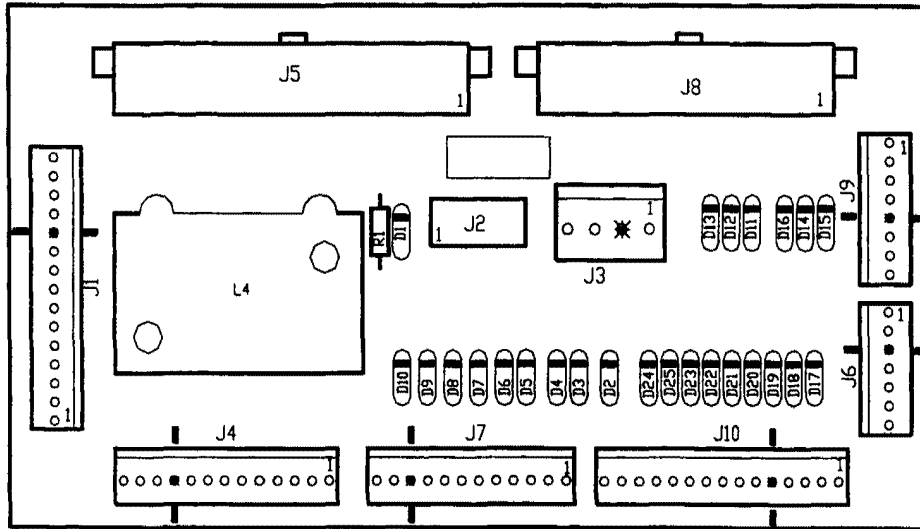
Each of these switches uses a green Individual LED board (P/N A-16908), and a blue Individual Photo Transistor board (P/N A-16909).

### OPTO SWITCH OPERATION:

The ball rolls between the Individual LED board and the Individual Photo Transistor board and breaks the beam. The broken beam 'makes' the switch.



## Coin Door Interface Board 04-12492



J1-1	BLK-YEL	Slam Tilt	J5-1	BLK-BRN	Slam Switch
J1-2	BLK-RED	Interlock Switch	J5-2	BLK-RED	Interlock Switch
J1-3	BLK-ORG	Plumb Bob Tilt	J5-3	BLK-ORG	Plumb Bob Tilt
J1-4	N/C		J5-4	BLK-YEL	Misc.
J1-5	BLK-GRN	Right Flipper 1	J5-5	BLK-GRN	Right Flipper 1
J1-6	BLK-BLU	Left Flipper 1	J5-6	BLK-BLU	Left Flipper 1
J1-7	BLK-VIO	Right Flipper 2	J5-7	BLK-VIO	Right Flipper 2
J1-8	BLK-GRY	Left Flipper 2	J5-8	BLK-GRY	Left Flipper 2
J1-9	N/C		J5-9	GRY-BRN	Enter Button
J1-10	N/C		J5-10	GRY-RED	Up Button
J1-11	Key		J5-11	BLU	Counter Signal
J1-12	N/C		J5-12	GRY-YEL	+12V
J1-13	BLK	Flipper Switch Ground	J5-13	ORG-BRN	Coin 1
J1-14	GRY-YEL	+12V	J5-14	ORG-RED	Coin 2
J1-15	N/C	Ground	J5-15	ORG-BLK	Coin 3
J2	Ribbon Cable		J5-16	ORG-YEL	Coin 4
J3-1	BLU	For DBV	J5-17	ORG-GRN	Coin 5
J3-2	Key		J5-18	ORG-BLU	Coin 6
J3-3	N/C		J5-19	ORG-VIO	Coin 7
J3-4	BRN	For DBV	J5-20	ORG-GRY	Coin 8
J4-1	WHT-YEL	Lamp Row 4	J5-21	GRY-ORG	Down Button
J4-2	YEL-WHT	Lamp Column 2	J5-22	GRY-BLK	Escape Button
J4-3	BLK	Switch Ground	J5-23	VIO-GRY	Counter Power
J4-4	BLK-BRN	Coin 1 Left	J5-24	BLK	Ground
J4-5	N/C	Coin 2 Center	J6	Not Used	
J4-6	BLK-RED	Coin 3 Right	J7-1	GRN-BRN	Switch Column 1
J4-7	WHT-GRY	Escape Button	J7-2	GRN-RED	Switch Column 2
J4-8	ORG-RED	Down Button	J7-3	N/C	
J4-9	ORG-GRN	Up Button	J7-4	N/C	
J4-10	Key		J7-5	N/C	
J4-11	BLK-BLU	Enter Button	J7-6	N/C	
J4-12	GRN-BRN	Slam Column	J7-7	N/C	
J4-13	BLK-GRN	Slam Row	J7-8	WHT-ORG	Start Button
			J7-9	WHT-ORG	Switch #23
			J7-10	Key	
			J7-11	N/C	
			J7-12	N/C	

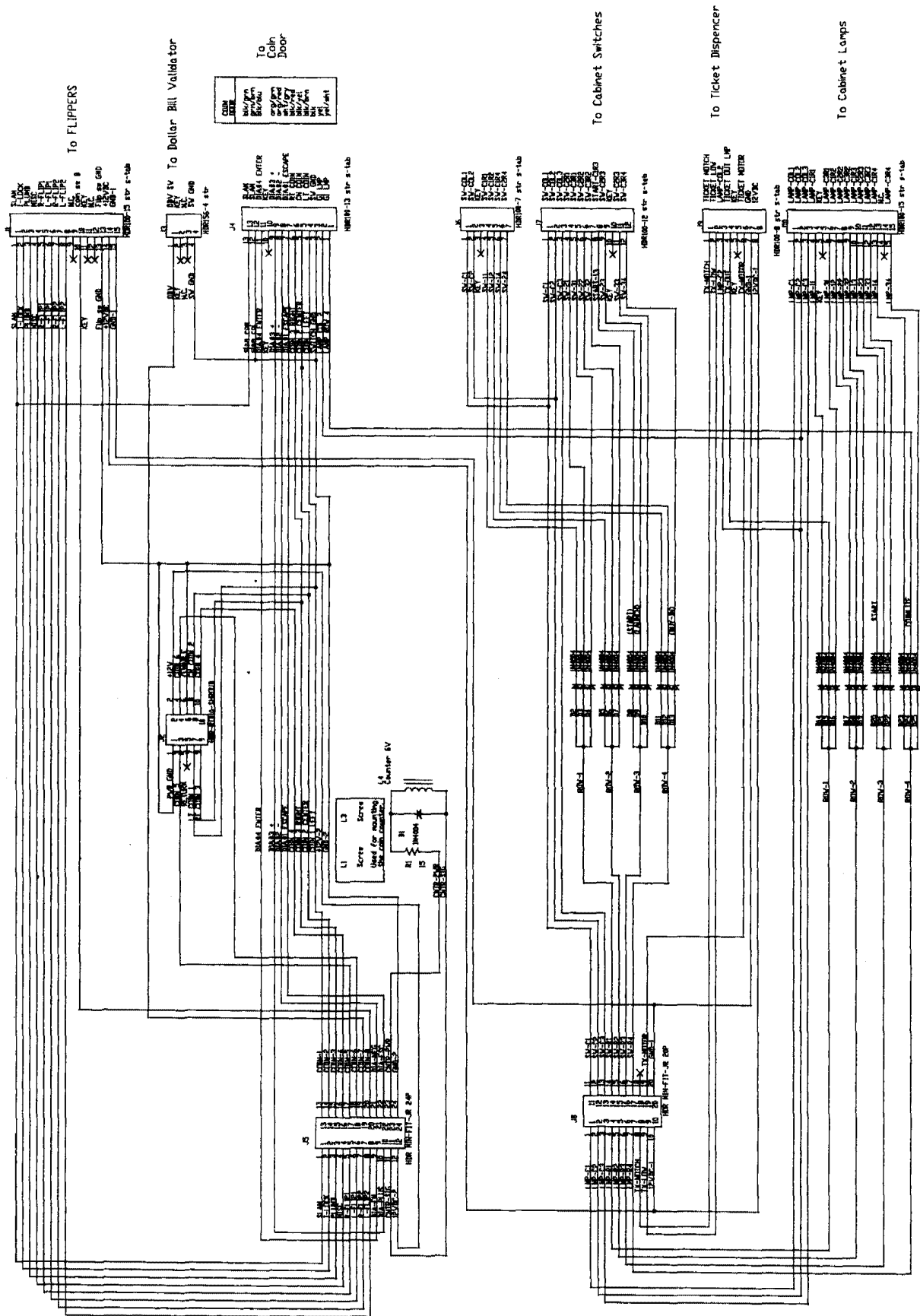
**Coin Door Interface Board Continued...**

J8-1 YEL-VIO Lamp Column 1  
J8-2 YEL-RED Lamp Column 2  
J8-3 YEL-ORG Lamp Column 3  
J8-4 BRN-BLK Lamp Row 1  
J8-5 BRN-RED Lamp Row 2  
J8-6 BRN-ORG Lamp Row 3  
J8-7 BRN-YEL Lamp Row 4  
J8-8 GRY-GRN Ticket Notch  
J8-9 GRY-BLU Ticket Low  
J8-10 GRY-YEL +12V  
J8-11 GRN-BRN Switch Column 1  
J8-12 GRN-RED Switch Column 2  
J8-13 GRN-ORG Switch Column 3  
J8-14 WHT-BRN Switch Row 1  
J8-15 WHT-RED Switch Row 2  
J8-16 WHT-ORG Switch Row 3  
J8-17 WHT-YEL Switch Row 4  
J8-18 Key  
J8-19 WHT Ticket Motor  
J8-20 BLK Ground

J9 Not Used

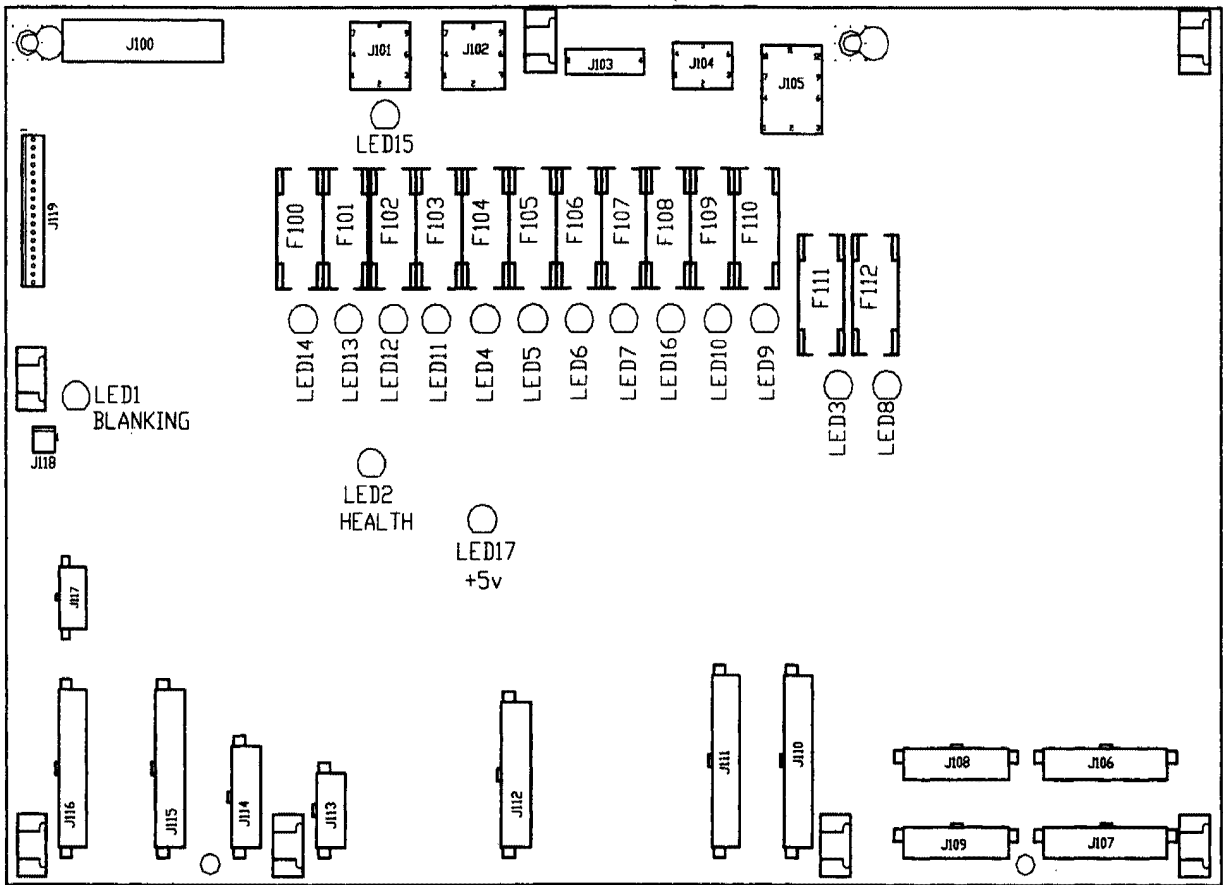
J10-1 N/C  
J10-2 YEL-RED Lamp Column 2  
J10-3 YEL-BRN Lamp Column 3  
J10-4 Key  
J10-5 N/C  
J10-6 N/C  
J10-7 N/C  
J10-8 N/C  
J10-9 N/C  
J10-10 BRN-ORG Lamp 13  
J10-11 ORG-BRN Lamp 23  
J10-12 N/C  
J10-13 N/C  
J10-14 N/C  
J10-15 N/C

# Coin Door Interface Board Schematic 04-12492





## Power Driver Board Assembly 04-12329



**J100** DB25 Parallel Port Extension Cable for Data to/from CPU motherboard

J101-1/J102-1	RED-BRN	Power for solenoids 1 to 4
J101-2/J102-2	RED-BLK	Power for solenoids 5 to 8
J101-3/J102-3	RED-ORG	Power for solenoids 9 to 12
J101-4/J102-4	BLK	Ground
J101-5/J102-5	BLK	Ground
J101-6/J102-6	ORG	Signal Ground
J101-7/J102-7	RED-YEL	Power for solenoids 13 to 16
J101-8/J102-8	RED-WHT	+20V flashlamp power
J101-9/J102-9	GRY-YEL	+12V unregulated power

J103-1	RED-GRN	Power for lower right flipper
J103-2	RED-BLU	Power for lower left flipper
J103-3	RED-VIO	Power for upper right flipper
J103-4	RED-GRY	Power for upper left flipper

J104-1	50V AC
J104-2	50V AC
J104-3	No Connection
J104-4	20V AC
J104-5	20V AC
J104-6	No Connection

**Power Driver Board Continued...**

J105-1	BLU-WHT	18V AC Secondary for Lamp Matrix A
J105-2	BLU-WHT	18V AC Secondary for Lamp Matrix A
J105-3	WHT-BLU	18V AC Secondary for Lamp Matrix B
J105-4	WHT-BLU	18V AC Secondary for Lamp Matrix B
J105-5	BLK-YEL	51.4V AC Secondary
J105-6	BLK-YEL	51.4V AC Secondary
J105-7	WHT-RED	16V AC Secondary
J105-8	WHT-RED	16V AC Secondary
J105-9	WHT-GRN	9.8V AC Secondary
J105-10	WHT-GRN	9.8V AC Secondary
J105-11		No Connection
J105-12		No Connection

J106-1/J107-1	RED-BRN	Lamp Row 1B
J106-2/J107-2	RED-BLK	Lamp Row 2B
J106-3/J107-3	RED-ORG	Lamp Row 3B
J106-4/J107-4	RED-YEL	Lamp Row 4B
J106-5/J107-5	RED-GRN	Lamp Row 5B
J106-6/J107-6	RED-BLU	Lamp Row 6B
J106-7/J107-7	RED-VIO	Lamp Row 7B
J106-8/J107-8	RED-GRY	Lamp Row 8B
J106-9/J107-9		No Connection
J106-10/J107-10	YEL-BRN	Lamp Column 1B
J106-11/J107-11	YEL-RED	Lamp Column 2B
J106-12/J107-12	YEL-ORG	Lamp Column 3B
J106-13/J107-13	YEL-BLK	Lamp Column 4B
J106-14/J107-14	YEL-GRN	Lamp Column 5B
J106-15/J107-15	YEL-BLU	Lamp Column 6B
J106-16/J107-16	YEL-VIO	Lamp Column 7B
J106-17/J107-17	YEL-GRY	Lamp Column 8B
J106-18/J107-18		No Connection

J108-1/J109-1	BRN-BLK	Lamp Row 1A
J108-2/J109-2	BRN-RED	Lamp Row 2A
J108-3/J109-3	BRN-ORG	Lamp Row 3A
J108-4/J109-4	BRN-YEL	Lamp Row 4A
J108-5/J109-5	BRN-GRN	Lamp Row 5A
J108-6/J109-6	BRN-BLU	Lamp Row 6A
J108-7/J109-7	BRN-VIO	Lamp Row 7A
J108-8/J109-8	BRN-GRY	Lamp Row 8A
J108-9/J109-9	YEL-BRN	Lamp Column 1A
J108-10/J109-10	YEL-RED	Lamp Column 2A
J108-11/J109-11	YEL-ORG	Lamp Column 3A
J108-12/J109-12	YEL-BLK	Lamp Column 4A
J108-13/J109-13	YEL-GRN	Lamp Column 5A
J108-14/J109-14	YEL-BLU	Lamp Column 6A
J108-15/J109-15	YEL-VIO	Lamp Column 7A
J108-16/J109-16	YEL-GRY	Lamp Column 8A

**Power Driver Board Continued...**

J110-1/J111-1	BLU-BRN	Solenoid Drive 17
J110-2/J111-2	BLU-RED	Solenoid Drive 18
J110-3/J111-3	BLU-ORG	Solenoid Drive 19
J110-4/J111-4	BLU-YEL	Solenoid Drive 20
J110-5/J111-5	BLU-GRN	Solenoid Drive 21
J110-6/J111-6	BLU-BLK	Solenoid Drive 22
J110-7/J111-7	BLU-VIO	Solenoid Drive 23
J110-8/J111-8	BLU-GRY	Solenoid Drive 24
J110-9/J111-9	BRN-WHT	Solenoid Drive 41-Logic
J110-10/J111-10	ORG-WHT	Solenoid Drive 42-Logic
J110-11/J111-11	YEL-WHT	Solenoid Drive 43-Logic
J110-12/J111-12	BLU-WHT	Solenoid Drive 44-Logic
J110-13/J111-13	VIO-BRN	Solenoid Drive 1
J110-14/J111-14	VIO-RED	Solenoid Drive 2
J110-15/J111-15	VIO-ORG	Solenoid Drive 3
J110-16/J111-16	VIO-YEL	Solenoid Drive 4
J110-17/J111-17	VIO-GRN	Solenoid Drive 5
J110-18/J111-18	VIO-BLU	Solenoid Drive 6
J110-19/J111-19	VIO-BLK	Solenoid Drive 7
J110-20/J111-20	VIO-GRY	Solenoid Drive 8
J110-21/J111-21	VIO-WHT	Solenoid Drive 45-Logic
J110-22/J111-22	GRY-WHT	Solenoid Drive 46-Logic
J110-23/J111-23	BLK-WHT	Solenoid Drive 47-Logic
J110-24/J111-24	WHT	Solenoid Drive 48-Logic
J112-1	YEL-GRN	Solenoid Drive 33-Lower Right Flipper Power
J112-2	ORG-GRN	Solenoid Drive 34-Lower Right Flipper Hold
J112-3	YEL-BLU	Solenoid Drive 35-Lower Left Flipper Power
J112-4	ORG-BLU	Solenoid Drive 36-Lower Left Flipper Hold
J112-5	YEL-VIO	Solenoid Drive 37-Upper Right Flipper Power
J112-6	ORG-VIO	Solenoid Drive 38-Upper Right Flipper Hold
J112-7	YEL-GRY	Solenoid Drive 39-Upper Left Flipper Power
J112-8	ORG-GRY	Solenoid Drive 40-Upper Left Flipper Hold
J112-9	BLK-BRN	Solenoid Drive 25
J112-10	BLK-RED	Solenoid Drive 26
J112-11	BRN-BLK	Solenoid Drive 9
J112-12	BRN-RED	Solenoid Drive 10
J112-13	BRN-ORG	Solenoid Drive 11
J112-14	BRN-YEL	Solenoid Drive 12
J112-15	BRN-GRN	Solenoid Drive 13
J112-16	BRN-BLU	Solenoid Drive 14
J112-17	BRN-VIO	Solenoid Drive 15
J112-18	BRN-GRY	Solenoid Drive 16
J112-19	BLK-ORG	Solenoid Drive 27
J112-20	BLK-YEL	Solenoid Drive 28
J113-1	BLK-BRN	Direct Switch 17-Slam
J113-2	BLK-RED	Direct Switch 18-Interlock
J113-3	BLK-ORG	Direct Switch 19-Plumb Bob
J113-4	BLK-YEL	Direct Switch 20-Not Used
J113-5	GRY-YEL	+12V DC
J113-6	BLK-GRN	Direct Switch 21-Right Flipper Button
J113-7	BLK-BLU	Direct Switch 22-Left Flipper Button
J113-8	BLK-VIO	Direct Switch 23-Right Feature Button
J113-9	BLK-GRY	Direct Switch 24 Left Feature Button
J113-10	BLK	Ground

**Power Driver Board Continued...**

J114-1	ORG-BRN	Direct Switch 1-Left Coin Slot
J114-2	ORG-RED	Direct Switch 2-Center Coin Slot
J114-3	ORG-BLK	Direct Switch 3-Right Coin Slot
J114-4	ORG-YEL	Direct Switch 4-4 <sup>th</sup> Coin Slot
J114-5	ORG-GRN	Direct Switch 5-Not Used
J114-6	ORG-BLU	Direct Switch 6-Not Used
J114-7	GRY-YEL	+12V DC
J114-8	ORG-VIO	Direct Switch 7-Not Used
J114-9	ORG-GRY	Direct Switch 8-Not Used
J114-10	GRY-BLK	Direct Switch 9-Diagnostic 'Escape' Button
J114-11	GRY-ORG	Direct Switch 10-Diagnostic 'Down' Button
J114-12	GRY-RED	Direct Switch 11-Diagnostic 'Up' Button
J114-13	GRY-BRN	Direct Switch 12-Diagnostic 'Enter' Button
J114-14	BLK	Ground
J115-1/J116-1	GRN-BRN	Switch Column 1
J115-2/J116-2	GRN-RED	Switch Column 2
J115-3/J116-3	GRN-ORG	Switch Column 3
J115-4/J116-4	GRN-WHT	Switch Column 4
J115-5/J116-5	GRN-BLK	Switch Column 5
J115-6/J116-6	GRN-BLU	Switch Column 6
J115-7/J116-7	GRN-VIO	Switch Column 7
J115-8/J116-8	GRN-GRY	Switch Column 8
J115-9/J116-9	BLK-GRN	Direct Switch 13-Lower Right Flipper E.O.S.
J115-10/J116-10	BLK-BLU	Direct Switch 14-Lower Left Flipper E.O.S.
J115-11/J116-11	GRY-YEL	+12V
J115-12/J116-12	WHT-BRN	Switch Row 1
J115-13/J116-13	WHT-RED	Switch Row 2
J115-14/J116-14	WHT-ORG	Switch Row 3
J115-15/J116-15	WHT-YEL	Switch Row 4
J115-16/J116-16	WHT-GRN	Switch Row 5
J115-17/J116-17	WHT-BLU	Switch Row 6
J115-18/J116-18	WHT-VIO	Switch Row 7
J115-19/J116-19	WHT-GRY	Switch Row 8
J115-20/J116-20	BLK-VIO	Direct Switch 15-Upper Right Flipper E.O.S. (not used)
J115-21/J116-21	BLK-GRY	Direct Switch 16-Upper Left Flipper E.O.S. (not used)
J115-22/J116-22	BLK	Ground
J117-1		+12V
J117-2		+12V
J117-3	WHT	Drive 48-Logic-Ticket Driver
J117-4	GRY-VIO	+12V Coin Door Power
J117-5	GRY-GRN	Direct Switch 25-Ticket Notch
J117-6	GRY-BLU	Direct Switch 26-Ticket Low
J117-7	BLUE	Coin Counter
J117-8	BLK	Ground



### LAMP MATRIX A

COLUMN	1A YEL-BRN J108-9 Q5	2A YEL-RED J108-10 Q9	3A YEL-ORG J108-11 Q13	4A YEL-BLK J108-12 Q17	5A YEL-GRN J108-13 Q21	6A YEL-BLU J108-14 Q25	7A YEL-VIO J108-15 Q29	8A YEL-GRY J108-16 Q33
1A BRN-BLK J108-1 Q3	NOT USED 11A	TICKETS LOW 21A	NOT USED 31A	RIGHT POPPER ARROW 41A	MULTIBALL 51A	SHOOTER LANE 9 (TOP) 61A	LEFT SIDE 1 (BOTTOM) 71A	RIGHT SLINGSHOT (BOTTOM) 81A
2A BRN-RED J108-2 Q7	NOT USED 12A	NOT USED 22A	NOT USED 32A	EXTRA BALL 42A	CAPTURE 2 52A	UNDER RIGHT RAMP (LOW) 62A	LEFT SIDE 2 72A	RIGHT SLINGSHOT (SAUCER) 82A
3A BRN-ORG J108-3 Q11	START BUTTON 13A	LAUNCH BUTTON 23A	NOT USED 33A	MARTIAN ATTACK 43A	CAPTURE 1 53A	UNDER RIGHT RAMP (HIGH) 63A	LEFT SIDE 3 73A	RIGHT RETURN LANE (RIGHT) 83A
4A BRN-YEL J108-4 Q15	NOT USED 14A	COIN DOOR ILLUMINA. 24A	NOT USED 34A	STROKE OF LUCK 44A	CAPTURE ZONE ACTIVE 54A	UPPER RT. CORNER (LOW) 64A	LEFT SIDE 4 (TOP) 74A	RIGHT RETURN LANE (LEFT) 84A
5A BRN-GRN J108-5 Q19	RIGHT TOP LANE 15A	MOTHERSHIP MULTIBALL (RIGHT) 25A	LEFT DRAIN TO TROUGH 35A	LEFT SIDE SPOTLIGHT 45A	SHOOT AGAIN 55A	RIGHT ARCH (RIGHT) 65A	UNDER LEFT RAMP (BOTTOM) 75A	LEFT RETURN LANE (RIGHT) 85A
6A BRN-BLU J108-6 Q23	LEFT TOP LANE 16A	MOTHERSHIP MULTIBALL (LEFT) 26A	RIGHT DRAIN TO TROUGH 36A	CENTER ARROW 46A	BEHIND CENTER TARGETS 56A	RIGHT ARCH (LEFT) 66A	UNDER LEFT RAMP (TOP) 76A	LEFT RETURN LANE (LEFT) 86A
7A BRN-VIO J108-7 Q27	MARTIAN TARGET 4 (CENTER) 17A	LEFT RETURN LANE 27A	RIGHT RETURN LANE 37A	RIGHT MARTIAN (HIGH) 47A	UPPER RT. CORNER (MIDDLE) 57A	LEFT ARCH (RIGHT) 67A	BETWEEN L/R JETS 77A	LEFT SLINGSHOT (SAUCER) 87A
8A BRN-GRY J108-8 Q31	CENTER LOOP ARROW 18A	LEFT OUTLANE 28A	RIGHT OUTLANE 38A	RIGHT MARTIAN (LOW) 48A	NOT USED 58A	LEFT ARCH (LEFT) 68A	UPPER LEFT CORNER 78A	LEFT SLINGSHOT (BOTTOM) 88A

### LAMP MATRIX B

COLUMN	1B YEL-BRN J107-10 Q6	2B YEL-RED J107-11 Q10	3B YEL-ORG J107-12 Q14	4B YEL-BLK J107-13 Q18	5B YEL-GRN J107-14 Q22	6B YEL-BLU J107-15 Q26	7B YEL-VIO J107-16 Q30	8B YEL-GRY J107-17 Q34
1B RED-BRN J107-1 Q4	SECRET WEAPON 11B	BIG-O-BEAM 21B	MARS KNEADS WOMEN 31B	MARTIAN HARRY HOUR 41B	RIGHT LOOP ARROW 51B	MARTIAN TARGET 5 (RT. TOP) 61B	BOTTOM JET BUMPER 71B	SHOOTER LANE 1 (BOTTOM) 81B
2B RED-BLK J107-2 Q8	TOWER STRUGGLE 12B	RIGHT SAUCER BEAM (LEFT) 22B	RIGHT SAUCER BEAM (RT) 32B	ALIEN ABDUCTION 42B	RIGHT LOOP CIRCLE 52B	MARTIAN TARGET 6 (RT. MID.) 62B	NOT USED 72B	SHOOTER LANE 2 82B
3B RED-ORG J107-3 Q12	CENTER SAUCER BEAM (LEFT) 13B	WEAPONS 23B	SAUCER RIM 9 (RIGHT) 33B	LEFT SAUCER BEAM (LEFT) 43B	RIGHT RAMP ARROW 53B	MARTIAN TARGET 7 (RT. BOT.) 63B	LEFT JET BUMPER 73B	SHOOTER LANE 3 83B
4B RED-YEL J107-4 Q16	QUESTION MARK 14B	SAUCER 24B	SAUCER RIM 8 34B	SAUCER RIM 1 (LEFT) 44B	RIGHT RAMP CIRCLE 54B	MARTIAN TARGET 3 (LEFT TOP) 64B	LEFT OF LEFT TOP LANE 74B	SHOOTER LANE 4 84B
5B RED-GRN J107-5 Q20	CENTER SAUCER BEAM (RT.) 15B	FUEL 25B	SAUCER RIM 7 35B	SAUCER RIM 2 45B	LEFT LOOP ARROW 55B	MARTIAN TARGET 2 (LEFT MID.) 65B	BETWEEN L/R TOP LANES 75B	SHOOTER LANE 5 85B
6B RED-BLU J107-6 Q24	DRIVE-IN DEMOLITION 16B	LEFT SAUCER BEAM (RT.) 26B	SAUCER RIM 6 36B	SAUCER RIM 3 46B	LEFT RAMP ARROW 56B	MARTIAN TARGET 1 (LEFT BOT.) 66B	RIGHT OF RIGHT TOP LANE 76B	SHOOTER LANE 6 86B
7B RED-VIO J107-7 Q28	PARIS IN PERIL 17B	CENTER SAUCER BEAM (CNTR) 27B	SAUCER RIM 5 37B	SAUCER RIM 4 47B	LEFT LOOP CIRCLE 57B	RIGHT MARTIAN EYE 67B	TOP OF CENTER LOOP 77B	SHOOTER LANE 7 87B
8B RED-GRY J107-8 Q32	LEFT SLINGSHOT SPOTLIGHT 18B	RIGHT SLINGSHOT SPOTLIGHT 28B	NOT USED 38B	NOT USED 48B	LEFT RAMP CIRCLE 58B	LEFT MARTIAN EYE 68B	UPPER RT. CORNER (HIGH) 78B	SHOOTER LANE 8 88B

## SWITCH MATRIX

COLUMN	1 GRN-BRN J116-1 U45-18	2 GRN-RED J116-2 U45-17	3 GRN-ORG J116-3 U45-16	4 GRN-WHT J116-4 U45-15	5 GRN-BLK J116-5 U45-14	6 GRN-BLU J116-6 U45-13	7 GRN-VIO J116-7 U45-12	8 GRN-GRY J116-8 U45-11
ROW								
1 WHT-BRN J116-12 U51-7	RIGHT RAMP ENTRANCE 11	NOT USED 21	CENTER LOOP REED (BOTTOM) 31	TROUGH JAM 41	RIGHT LOCKUP 1 51	LEFT SLINGSHOT 61	MARTIAN TARGET 71	NOT USED 81
2 WHT-RED J116-13 U51-5	LEFT RAMP EXIT 12	NOT USED 22	CENTER LOOP REED (TOP) 32	TROUGH BALL 1 42	LEFT RAMP ENTRANCE 52	RIGHT SLINGSHOT 62	MARTIAN TARGET 72	NOT USED 82
3 WHT-ORG J116-14 U51-9	START BUTTON 13	LAUNCH BUTTON 23	CENTER TARGET 4 33	TROUGH BALL 2 43	NOT USED 53	LEFT JET BUMPER 63	MARTIAN TARGET 73	NOT USED 83
4 WHT-YEL J116-15 U51-11	NOT USED 14	NOT USED 24	CENTER TARGET 3 34	TROUGH BALL 3 44	NOT USED 54	RIGHT JET BUMPER 64	CENTER LOOP ROLLOVER 74	NOT USED 84
5 WHT-GRN J116-16 U57-7	DROP TARGET DOWN 15	LEFT LOOP (LOW) 25	CENTER TARGET 2 35	TROUGH BALL 4 45	NOT USED 55	BOTTOM JET BUMPER 65	CENTER TROUGH 75	MARTIAN TARGET 85
6 WHT-BLU J116-17 U57-5	LEFT OUTLANE 16	LEFT RETURN LANE 26	CENTER TARGET 1 36	RIGHT POPPER 46	NOT USED 56	NOT USED 66	RIGHT TOP LANE 76	MARTIAN TARGET 86
7 WHT-VIO J116-18 U57-9	RIGHT RETURN LANE 17	RIGHT OUTLANE 27	MARTIAN TARGET 37	JET EXIT 47	NOT USED 57	RIGHT LOOP (LOW) 67	LEFT TOP LANE 77	MARTIAN TARGET 87
8 WHT-GRY J116-19 U57-11	SHOOTER LANE 18	RIGHT RAMP EXIT 28	UP/DOWN RAMP UP 38	NOT USED 48	NOT USED 58	RIGHT LOOP (HIGH) 68	LEFT LOOP (HIGH) 78	NOT USED 88

= OPTO, TYPICALLY CLOSED

## COIN SLOT SWITCHES

DIRECT GROUND	ORN-BRN J114-1 U43-7	ORG-RED J114-2 U43-5	ORG-BLK J114-3 U43-9	ORG-YEL J114-4 U43-11	ORG-GRN J114-5 U48-7	ORG-BLU J114-6 U48-5	ORG-VIO J114-8 U48-9	ORG-GRY J114-9 U48-11
BLACK J114-14	LEFT COIN SLOT D1	CENTER COIN SLOT D2	RIGHT COIN SLOT D3	4 <sup>TH</sup> COIN OPTION D4	NOT USED D5	NOT USED D6	NOT USED D7	NOT USED D8

## DIAGNOSTIC SWITCHES

DIRECT GROUND	GRY-BLK J114-10 U50-7	GRY-ORG J114-11 U50-5	GRY-RED J114-12 U50-9	GRY-BRN J114-13 U50-11
BLACK J114-14	'ESCAPE' BUTTON D9	'DOWN' BUTTON D10	'UP' BUTTON D11	'ENTER' BUTTON D12

## PLAYFIELD FLIPPER SWITCHES (E.O.S.)

DIRECT GROUND	BLK-GRN J115-9 U56-7	BLK-BLU J115-10 U56-5	BLK-VIO J115-20 U56-9	BLK-GRY J115-21 U56-11
BLACK J115-22	LOWER RIGHT FLIPPER E.O.S. D13	LOWER LEFT FLIPPER E.O.S. D14	NOT USED D15	NOT USED D16

## CABINET FLIPPER SWITCHES

DIRECT GROUND	BLK-BRN J113-1 U49-7	BLK-RED J113-2 U49-5	BLK-ORG J113-3 U49-9	BLK-YEL J113-4 U49-11	BLK-GRN J113-6 U55-7	BLK-BLU J113-7 U55-5	BLK-VIO J113-8 U55-9	BLK-GRY J113-9 U55-11
BLACK J113-10	SLAM TILT D17	COIN DOOR CLOSED D18	PLUMB BOB TILT D19	NOT USED D20	RIGHT FLIPPER BUTTON D21	LEFT FLIPPER BUTTON D22	RIGHT FEATURE BUTTON D23	LEFT FEATURE BUTTON D24

## WARNINGS & NOTICES

### **WARNING**

**FOR SAFETY AND RELIABILITY**, substitute parts and equipment modifications are not recommended. Use of Non-WILLIAMS parts or modifications of game circuitry, may adversely affect game play, or may cause injuries.

**SUBSTITUTE PART OR EQUIPMENT MODIFICATIONS** may void FCC/CANADA Type Acceptance.

**BECAUSE THIS GAME IS PROTECTED** by Federal copyright, trademark, and patent laws, unauthorized game conversions may be illegal under Federal law.

**THIS 'CONVERSION' PRINCIPLE ALSO APPLIES** to unauthorized facsimiles of WILLIAMS equipment, logos, designs, publications, assemblies, and games (or game features not deemed to be public domain), whether manufactured with WILLIAMS components or not.

### **NOTICE**

WILLIAMS, Lane-change and Multi-ball are trademarks of WILLIAMS ELECTRONICS GAMES, INC. Entire contents of this manual © 1999 WILLIAMS ELECTRONICS GAMES, INC.

### **WARNING**

**NOTE:** This equipment has been tested and found to comply with the limits for a Class A digital device, pursuant to Part 15 of the FCC Rules. These limits are designed to provide reasonable protection against harmful interference when the equipment is operated in a commercial environment. This equipment generated, uses, and can radiate radio frequency energy and if not installed and used in accordance with the instruction manual, may cause harmful interference to radio communications. Operation of this equipment in a residential area is likely to cause harmful interference in which case the user will be required to correct the interference at his own expense.

This Class B digital apparatus meets all requirements of the Canadian Interference-Causing Equipment Regulations.

Cet appareil numérique de la classe B respecte toutes les exigences du Règlement sur le matériel brouilleur du Canada.

### **RF Interference Notice**

CABLE HARNESS PLACEMENTS and ground strap routing on this game have been designed to keep RF radiation and conduction within levels accepted by the FCC Rules.

TO MAINTAIN THESE LEVELS, reposition harnesses and reconnect ground straps to their original placements, if they become disconnected during maintenance.

**FCC/CANADA STICKER.** Check the back of your game to verify that an FCC/CANADA certification sticker was attached to your game at the factory. All games that leave the WILLIAMS plant have been tested and found to comply with FCC/CANADA Rules. Because the sticker is proof of this fact, legal repercussions to the owner and distributor may result, if the sticker is missing. If you receive a game that has no FCC/CANADA sticker, call WILLIAMS for advice or write us a note on your Game Registration Card. Be sure that the card bears your game's serial number.

### **For Service...**

Call your authorized Williams Distributor

### **Williams Electronics Games, Inc.**

3401 N. California Avenue  
Chicago, IL 60618

© 1999 Williams Electronics Games, Inc. All Rights Reserved.

