

THE SIMPSONS™
©1990 TWENTIETH CENTURY FOX
FILM CORPORATION
ALL RIGHTS RESERVED

MATT GROENING

DATA EAST PINBALL ©

1990 Janice Avenue
Melrose Park, IL 60160
708-345-7700
FAX 708-345-7718
1-800-KICKERS

CPU JUMPER TABLE

Game	CPU* Version	ROM Location	Jumpers	
			Installed	Removed
Laser Wars	Ver 1	5C	J1b,J3,J4,J6a,J7a,&J8	J1a,J2,J5,J6,&J7b
	Ver 2	5C	J1b,J3,J4,J5a,J6a,J7b,&J8	J1a,J2,J5,J5b,J6b,&J7a
Secret Service	Ver 2	5B,5C	J1b,J3,J4,J5b,J6b,J7b,&J8	J1a,J2,J5,J5a,J6a,&J7a
Torpedo Alley	Ver 2	5B,5C	J1b,J3,J4,J5b,J6b,J7b,&J8	J1a,J2,J5,J5a,J6a,&J7a
Time Machine	Ver 2	5B,5C	J1b,J3,J4,J5b,J6b,J7b,&J8	J1a,J2,J5,J5a,J6a,&J7a
Playboy	Ver 2	5B,5C	J1b,J3,J4,J5b,J6b,J7b,&J8	J1a,J2,J5,J5a,J6a,&J7a
ABC M.N. Football	Ver 2	5B,5C	J1b,J3,J4,J5b,J6b,J7b,&J8	J1a,J2,J5,J5a,J6a,&J7a
Robocop	Ver 2	5B,5C	J1b,J3,J4,J5b,J6b,J7b,&J8	J1a,J2,J5,J5a,J6a,&J7a
Phantom of the Opera	Ver 2	5B,5C	J1b,J3,J4,J5b,J6b,J7b,&J8	J1a,J2,J5,J5a,J6a,&J7a
Back to the Future	Ver 3	5B,5C	J1b,J3,J4,J5b,J6b,J7b,&J8	J1a,J2,J5,J5a,J6a,&J7a
The Simpsons	Ver 3	5B,5C	J1b,J3,J4,J5b,J6b,J7b,&J8	J1a,J2,J5,J5a,J6a,&J7a

*Version 1 has a 2K RAM which is a 24-pin IC at location 5D.

*Version 2 has an 8K RAM which is a 28-pin IC at location 5D.

Power-up CPU Self Tests

Upon power-up, the CPU board performs a series of self tests of major components. Turn the game on while observing the LEDs on the CPU board. Tests of the PIAs, RAM, and EPROMs are performed automatically and results of the test are indicated by the PIA LED.

With all tests passed, the LEDs illuminate in the following sequence at power turn-on. The PIA and +5V LEDs illuminate immediately. Approximately 1/2-second later the PIA LED goes out and the Blanking LED illuminates; the +5V and Blanking LEDs remain illuminated until the game is turned off. Test failures are indicated with the PIA LED:

PIA LED	SUSPECT COMPONENT
Stays On	One of the 6821 PIAs
Flashes 1 Time	6064 RAM at location D5.
Flashes 2 Times	EPROM at location B5.
Flashes 3 Times	EPROM at location C5.

QUICK REFERENCE FUSE CHART

PPB BOARD

F1 5A Slo-Blo G.I. 6.3VAC
 F2 5A Slo-Blo G.I. 6.3VAC
 F3 5A Slo-Blo G.I. 6.3VAC
 F4 5A Slo-Blo G.I. 6.3VAC
 F5 5A Slo-Blo Flipper Power 48VAC
 F6 3A Slo-Blo PPB Solenoids/Flash Lamps (34VDC)

POWER SUPPLY BOARD

F1 7A Slo-Blo +5VDC Regulator Input (9VAC)
 F2 7A Slo-Blo +5VDC Regulator Input (9VAC)
 F3 0.25A Slo-Blo Display Reg. Input (90VAC)
 F4 8A Slo-Blo Switched Illumination Buss (18VDC)
 F5 4A Slo-Blo Solenoid Buss (34VDC)
 F6 5A Slo-Blo Solenoid Buss (34VDC)

THE SIMPSONS TABLE OF CONTENTS

GAME SPECIFICATIONS	1
Power Requirements	1
Major Assembly and Fuse Locations.....	1
Circuit Board PROM Locations.....	1
Transportation	1
ASSEMBLY PROCEDURES	1
GAME OPERATION	3
Standard Features	3
Manual Percentaging	3
Game Specific Features	4
AUDIT FUNCTIONS	5
General	5
'Quick Look' Functions	5
Expanded Functions	7
Game Specific Functions	7
GAME ADJUSTMENTS	11
General	11
Replay and Generic Features.....	11
Single-Function Difficulty Adjustments	13
Novelty/5-Ball/Add-A-Ball Rules	13
Game Pricing	14
Additional Generic Features.....	16
Game Specific Features	17
DIAGNOSTIC PROCEDURES	19
Entering Diagnostics	19
Service Credits.....	19
Tech Alert.....	19
Burn In Minutes.....	20
Sound Tests.....	20
Digital Display Tests	21
Switch Tests.....	22
Lamp Tests	24
Coil/Flash Lamp Tests.....	26
Return to Game Over	26
PARTS IDENTIFICATION	28
Cabinet Parts	28
Playfield Top Parts.....	29
Playfield Rubbers	30
Backbox Parts	30
UNIQUE PARTS	31-36 ,59
SERVICING DIAGRAMS	37
Power Wiring Diagram	37
Cabinet Wiring Diagram	38
Combined Display Connections	39
Backbox Wiring Diagram	41
Playfield Coil/Flash Lamp Wiring Diagram	42
Playfield Special Coil Diagram	43
Playfield Switch Wiring Diagram	44
Playfield Lamp Wiring Diagram	45
CPU Board	46
Power Supply Board	51
Digital Stereo Sound Board	52
Display Board	54
PPB Board	56
Solid State Flipper	57

DATA EAST LIMITED WARRANTY

Data East USA, Inc., ("Seller") warrants only to the initial purchaser of its products that the items listed below are free from defects in material and workmanship under normal use and service for the warranty period specified:

PRINTED CIRCUIT BOARDS (GAME LOGIC) 60 DAYS

No other parts of Seller's product are warranted.

Warranty periods are effective from the initial date of shipment from Seller to its authorized distributors.

Seller's sole liability shall be, at its option, to repair or replace products which are returned to Seller during the warranty periods specified, provided:

1. Seller is notified promptly upon discovery by purchaser that stated products are defective.
2. Such products are properly packaged and then returned freight prepaid, to Seller's plant.

This warranty does not apply to any parts damaged during shipment and/or due to improper handling, or due to improper installation or usage, or alteration. In no event shall the Seller be liable for any anticipated profits, loss of profits, loss of use, accidental or consequential damages or any other losses incurred by the customer in connection with the purchase of a Data East USA., product.

WARRANTY DISCLAIMER

EXCEPT AS SPECIFICALLY PROVIDED IN A WRITTEN CONTRACT BETWEEN SELLER AND PURCHASER, THERE ARE NO OTHER WARRANTIES, EXPRESS OR IMPLIED, INCLUDING ANY IMPLIED WARRANTIES OF MERCHANTABILITY OR FITNESS FOR A PARTICULAR PURPOSE.

WARNING—This equipment generates, uses, and can radiate radio frequency energy, and if not installed and used in accordance with the instructions manual, may cause interference to radio communications. It has been tested and found to comply with the limits for a Class A computing device pursuant to Subpart J of Part 15 of FCC Rules, which are designed to provide reasonable protection against such interference when operated in a commercial environment. Operation of this equipment in a residential area is likely to cause interference in which case the user at his own expense will be required to take whatever measures may be required to correct the interference.

GAME SPECIFICATIONS

POWER REQUIREMENTS

This game is provided with a 3-prong plug and **must be connected to a properly grounded outlet to reduce shock hazard** and insure proper game operation. Refer to AC Power Wiring Diagram for transformer connections required for normal, high, and low line conditions.

Normal Line: 109 to 129 Vac (211 to 225 Vac)

High Line: (226 to 235 Vac)

Low Line: 95 to 108 Vac (200 to 210 Vac)

MAJOR ASSEMBLY AND FUSE LOCATIONS

Refer to the Game Illustration (page 2) to identify locations of the major assemblies, and fuse values and locations.

PROM SUMMARY

CPU Board: Location 5B, 5C

Sound Board: Locations 6F (Voice ROM 1), 4F (Voice ROM 2), and 7F (Sound ROM)

TRANSPORTATION

To reduce the possibility of damage, observe the following precautions whenever transporting the game. Lower the backbox and secure it to the cabinet. Remove the legs and secure the game within the transporting vehicle.

GAME ASSEMBLY PROCEDURES (Refer to the Game Illustration on page 2)

1. Open the top of the carton and lay it on its side with the bottom of the cabinet down. Using the plastic banding strip as a handle, slide the game out of the carton.
2. Remove all packing material. Locate cabinet legs in filler packing inserts and assembly parts package in the cashbox. There should be four leg levelers, eight leg bolts, three pinballs and a large Allen Wrench used for securing the backbox.
3. Attach leg leveler from the parts package to each leg, make sure that each leveler is threaded through a hex nut before threading it into the leg.
4. Support rear of cabinet and attach rear legs using two leg bolts for each leg.
5. Support front of cabinet and attach front legs using two leg bolts for each leg.
6. While assuring that no cables are being pinched, carefully raise the backbox and secure it in its upright position by inserting the Allen Wrench in the hole in the back of the cabinet and rotating the wrench 270 degrees (3/4 turn).

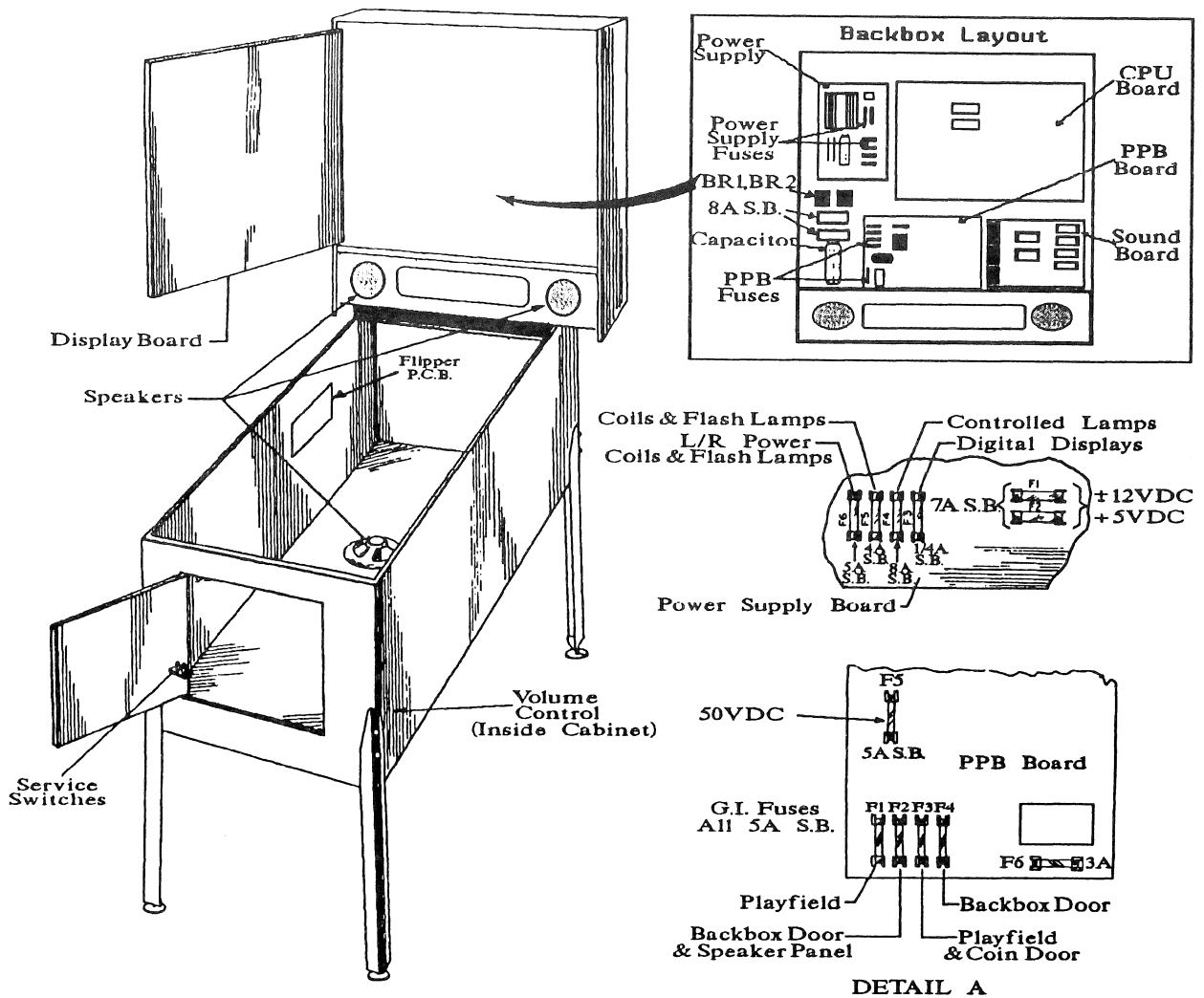

GAME ILLUSTRATION

7. Remove the backbox keys from the clip on the inside of the coin door and unlock and carefully remove the backglass. Set the backglass aside.
8. Carefully remove the playfield glass and set it aside.
9. Check all connectors in the backbox for loose wire terminations. Reseat any loose wire by pushing in on the terminal.
10. Push on all connectors plugged into the CPU board, Sound Board, Power Supply Boards, and (on Insert board) Display board to check that they are properly seated.
11. Check that the fuses on the Power Supply board, PPB board and fuse panel are seated properly.
12. Raise the playfield and the support bar on the right side of the cabinet; support the playfield by inserting the support bar into the countersunk notch on the bottom side.
13. Check all cabinet cable and playfield lamp board connector terminations.

14. Remove the Plumb tilt from the parts package and install on the panel on the inside left of the cabinet. Note that this game is not equipped with a ball roll tilt.
15. Lower the playfield and level the playfield side-to-side by adjusting leg levelers.
16. Using an inclinometer (protractor) adjust the pitch of the playfield to 6.5 degrees. If a pitch indicating meter is not available, adjust the front levelers to the lowest position and extend the rearleg levelers approximately half way out. Readjust side-to-side level as required.

NOTE

The playfield incline affects difficulty of play. Use the recommended incline; game difficulty is best varied using game adjustments.

17. Check the plumb tilt and adjust as required.
18. If desired, perform any self tests at this time. With the insert door closed, carefully reinstall and lock the backglass.
19. Place the three pinballs on the playfield near the outhole and carefully reinstall the playfield glass.
20. If desired, make game pricing and Add-A-Ball, Novelty, or 5-Ball Play adjustments at this time.

GAME OPERATION

STANDARD FEATURES

Insert coin(s), the game makes a sound for the first credit and generates sounds for each subsequent coin and the Player 4 display indicates the number of credits posted. Depress the credit button and a start-up sound is produced, the posted credits are reduced by one, Player 1 display flashes, Player 4 display indicates BALL 1, and a ball is served to the plunger trough. Additional players may be added by depressing the Credit button before the end of ball 1.

The second closure (adjustable) of the plumb bob tilt switch tilts the ball in play. Closure of the slam tilt switch in the coin door ends the current game(s).

At the end of each ball, earned bonuses are collected. At the end of the last ball for the last player and after bonuses are collected, the system produces a random 2-digit number (a multiple of 10; 00 to 90) for a Match feature (adjustable). Matching the last two digits of a player score with this number awards a credit. Players exceeding high score levels receive free credits (adjustable) and are able to enter their initials with the new High Score achieved. The game then proceeds into the game-over mode and then to the attract mode. A custom message (adjustable) can be displayed during the attract mode.

MANUAL PERCENTAGING

This game is equipped with Manual Percentage Adjustment.

As previously with our games, you can either set operator adjustments for a replay percent or you can set a fixed replay score.

If you set operator adjustments for a particular replay percent, the game will compute a recommended score to keep the game at that replay percentage. If a change is recommended and the game coin door is opened, the displays will indicate a recommended replay score to beat and make a sound to alert the operator. By pressing the start button, the score to beat will be changed to the recommended level. If you close the coin door or go into audit or adjustment mode, no score change will be made.

You may choose to ignore the recommended change; for example, you may not think last week's players were the usual crowd. Just close the door and the message will disappear without altering the existing level. Or you may choose to make a different score to beat adjustment; this is done by utilizing adjustment AD02.

GAME SPECIFIC FEATURES

HOW TO PLAY THE SIMPSONS

Top Lanes advance Doughnut Multipliers 2X through 6X. making 6X lights Extraball either on the Outlane or by the Top Right Ball Lock. Top Lanes also advance Simpson MILLIONS spell out for the one million point Simpson Million shot.

Life's A Mystery! Shoot the Ultimate Behemoth Ramp twice in a row to score Mystery Scores of 500K, Catch-Up, Bonus Hold plus 100K , Extra Ball, 5X Doughnuts or Double Your Score. When you shoot the ramp it also spots a letter in M-I-L-L-I-O-N-S for a Million point shot.

Bounce around the Turbo Bumpers to build the Nuclear Power Value , ride down the Return Lanes to any Ball Lock and collect the Hot Reactor points from the respective Left , Center and Right Cooling Tower Instantly.

Multiball and Bowling can be fun. Complete the Center 3 Bank to qualify ball locks. Lock one ball and your ready for Two Ball Play. In Two Ball Play, lock both balls in time for an amazing 3 balls on the playfield at one time. When your in Three Ball Play, knock down the Bowling Pins to light the Ultimate Behemoth for the Nuclear Jackpot. When Jackpots lit, the longer you wait to make the shot, the more points it's worth.

Stop by the convenient store and say hi to Apu. Exit back out the front door when the Laser Kick's lit. Complete Chocolate, Double Chocolate and Triple Chocolate to relight the Laser Kick For fun shopping please.

Barts causing trouble again as he takes aim at Skinner, Krubopple, Sherri & Terri and Nelson to light Bonus Hold, Extraball And Special. You must collect a lit value to advance the Five Bank. If you miss the Special, it get's twice as hard the next time around.

Finally it's end of the game and match time as Homer tries his hand at Lotto Fever and Homers Lucky Scratch and Match.

Refer to the Game Specific Adjustments on page17 for additional information.

AUDIT FUNCTIONS

GENERAL

There are 81 audit functions provided for accounting purposes and for evaluation of game difficulty adjustments. Audit functions are split into two groups. There are eight most-used audits (AU01 through AU08) in a 'quick look' group and 72 less-used audits (E AU10 through E AU81), in an 'expanded' group. The various auditing functions are summarized in the **AUDITING FEATURES TABLE** and, when accessed, are shown on the player score displays. The *Audit Number* is shown in the Player 3 Display, the *Description* in the Player 1 and 2 Displays, and the *Audit Total* in the Player 4 Display. Access and control is provided from switches located on the inside of the coin door.

To access audit functions, open the coin door and make sure that the FORWARD/REVERSE switch is in the FORWARD (up) position. Depress the STEP switch and the game name is shown in the Player 1 and 2 displays, the Player 3 display is blank, and the PROM revision level is shown in the Player 4 display. This indicates access to audit functions.

With the FORWARD/REVERSE push-button switch still in the FORWARD (up) position, depressing the STEP push-button switch advances through the audit functions one at a time. To review lower-numbered functions, set the forward/reverse push-button switch to the REVERSE (down) position and operate the STEP push-button switch.

To access expanded audits, operate the step push-button until AU09, EXPAND AUDITS is displayed. Set the choice to ON as indicated in the Player 4 display by depressing the Game Start push-button and then depress the step push-button. The request is installed and E AU10 is displayed. When you exit audits and adjustments, the AU09 setting is returned to off for the next time that a review of audits are required.

Audit totals may be reset to zero using Game Adjustment Ad11, Audits Reset. Game adjustments (Ad01 to Ad13 and E Ad14 to E Ad48) begin after the last audit function (AU09 or E AU81). Once audits functions have been recorded, and if no adjustments are required, you may return the game to the attract mode. If adjustments are required, continue pressing the STEP button until the game adjustments are reached. See Game Adjustments for details.

'QUICK LOOK' FUNCTIONS

Total Paid Credits (AU01) - the total number of paid credits is displayed.

Free Percent (AU02) is Free Total (E AU24) divided by Plays Total (E AU25).

Ball Time Average (in seconds) (AU03) is Total Play Time divided by Total Balls Played (AU10).

Average Game Time (AU04) is the Average Game Time expressed in minutes and seconds.

Coins (AU05, 06, and 07) - These three audit totals are provided to show the amount of coins registered for the left, right, and center coin chutes, respectively.

Total Coins (AU08) is the total number of coins dropped through all 3 coin chutes.

Expand Audits (AU09) permits viewing of expanded audits.

The Simpsons Audit Table

Audit Number (Player 3 Display)	Audit Description (Players 1 & 2 Displays: totals in Player 4 Display)	Audit Number (Player 3 Display)	Audit Description (Players 1 & 2 Displays: totals in Player 4 Display)
AU 01	The Simpsons PROM ID	E AU 42	Drain Left
AU 02	Total Paid Credits	E AU 43	Drain Center
AU 03	Percent Free	E AU 44	Drain Right
AU 04	Ball Time Average	E AU 45	2x
AU 05	Average Game Time	E AU 46	3x
AU 06	Coins Left	E AU 47	4x
AU 07	Coins Right	E AU 48	5x
AU 08	Coins Center	E AU 49	6X
AU 09	Total Coins	E AU 50	Outlane Extra Ball
E AU 10	Expand Audits (ON/OFF)	E AU 51	Hole Extra Ball
E AU 11	Balls Total	E AU 52	Million Lit
E AU 12	Extra Ball Total	E AU 53	Million Awards
E AU 13	Extra Ball Percent	E AU 54	Mystery Active
E AU 14	1 Replay Awards	E AU 55	Mystery 500,000
E AU 15	2 Replay Awards	E AU 56	Mystery Catch-Up
E AU 16	3 Replay Awards	E AU 57	Mystery Double
E AU 17	4 Replay Awards	E AU 58	Mystery Extra Ball
E AU 18	Replay Total	E AU 59	Mystery Bonus hold
E AU 19	Replay Percent	E AU 60	Mystery 5X
E AU 20	Special Total	E AU 61	2 Ball Multiball
E AU 21	Special Percent	E AU 62	3 Ball Multiball
E AU 22	Match Total	E AU 63	Locked Left
E AU 23	Hi Score Wins	E AU 64	Locked Center
E AU 24	High Score Percent	E AU 65	Locked Right
E AU 25	Free Total	E AU 66	Tower Left
E AU 26	Plays Total	E AU 67	Tower Center
E AU 27	0.0 - 1.4 Mil Games	E AU 68	Tower Right
E AU 28	1.5 - 2.4 Mil Games	E AU 69	Jackpot Lit
E AU 29	2.5 - 3.4 Mil Games	E AU 70	Jackpot 1,000,000
E AU 30	3.5 - 4.9 Mil Games	E AU 71	Jackpot 2,000,000
E AU 31	5.0 - 9.9 Mil Games	E AU 72	Jackpot 3,000,000
E AU 32	10 + Mil Games	E AU 73	Jackpot 4,000,000
E AU 33	Average Scores	E AU 74	Right Bank 50,000
E AU 34	Games 1Player	E AU 75	Right Bank Bonus Hold
E AU 35	Games 2Player	E AU 76	Right Bank Extra Ball
E AU 36	Games 3Player	E AU 77	Right Bank Special
E AU 37	Games 4Player	E AU 78	Right Bank 100,000
E AU 38	Buy In Games	E AU 79	Laser Lit
E AU 39	Attract Minutes	E AU 80	Laser Kicked
E AU 40	Cycles H.S. Reset	E AU 81	Ramp Shots
E AU 41	Coin No Credit		
	Service Credits		

EXPANDED FUNCTIONS

Balls Total (E AU10) is the total of regular and extra balls.

Extra Ball Total (E AU11) is the total number of extra balls awarded.

Extra Ball Percentage (AU12) is AU11 divided by Plays Total (AU25).

Replay Awards (E AU13 through 16) provide the total awards (credit, extra ball, or audit) for replay levels 1 through 4, respectively.

Replay Total (E AU17) is the total awards (credits, extra balls, or audit only) for exceeding replay score levels.

Replay Percentage (E AU18) is the Replay Total awards for exceeding replay score levels (E AU17) divided by Plays Total (E AU25).

Special Total (E AU19) is the total awards (credits, extra balls, or scores) for making specials.

Special Percentage (E AU20) is Special Total (E AU19) divided by Plays total (E AU25).

Match Total (E AU21) is the total credits awarded for matching the last two digits of the score with the system-generated Match Number at the end of the game. Percentage of match credits will be adjustable from 0% to 10%, by E Ad 14 if enabled.

High Score Wins (E AU22) is the total credits awarded for exceeding the high-score-to-date scores.

High Score Percentage (E AU23) is High Score Wins (E AU22) divided by Plays Total (E AU25).

Free Total (E AU24) is the total free credits for replays, high-score-to-date, specials, and match.

Plays Total (E AU25) is the sum of Total Paid Credits (AU01) and Free Total (E AU24). Note that free credits are not recorded in the audits until they are actually used.

0.0 - 1.4 Mil Games (E AU26) provides the total number of games the Player's final score was between 0 and 1,499,990 points.

1.5 - 2.4 Mil Games (E AU27) provides the total number of games the Player's final score was between 1,500,000 and 2,499,990 points.

2.5 - 3.4 Mil Games (E AU28) provides the total number of games the Player's final score was between 2,500,000 and 3,499,990 points.

3.5 - 4.9 Mil Games (E AU29) provides the total number of games the Player's final score was between 3,500,000 and 4,999,990 points.

5.0 - 9.9 Mil Games (E AU30) provides the total number of games the Player's final score was between 5,000,000 and 9,999,990 points.

10 + Mil Games (E AU31) provides the total number of games the Player's final score was over 10,000,000 points.

Average Scores (E AU32) provides the Average Score by adding the Final Score of each game to a table and dividing this sum by the Total Plays (E AU24).

Games - Player (E AU33 through 36) provide individual totals of 1- player, 2-player, 3-player, and 4-player games, respectively.

Buy-In-Games (E AU37) provides the total number of times a game was bought into retaining lit game features.

Attract Minutes (E AU38) provides the number of minutes the game is in Attract mode (Factory use).

Cycles High Score Reset (E AU39) provides the number of times that the high score levels have been automatically reset (if enabled).

Coin No Credit (E AU40) provides the number of times the coin switch was closed without awarding credit(s)-This option is used in multiple coin conditions.(ie. 2 quarters 1 Play)

Service Credits (AU41) provides the total number of Service credits added to the game. See *Game Diagnostics* on page 19 for instructions regarding entry of Service Credits.

Drain Left (E AU42) provides the number of times the ball drained out the left drain.

Drain Center (E AU43) provides the number of times the ball drained out the center drain.

Drain Right (E AU44) provides the number of times the ball drained out the right drain.

GAME SPECIFIC FUNCTIONS

2X (E AU45) provides the number of times 2x bonus was made.

3X (E AU46) provides the number of times 3x bonus was made.

4X (E AU47) provides the number of times 4x bonus was made.

5X (E AU48) provides the number of times 5x bonus was made.

6X (E AU49) provides the number of times 6x bonus was made.

Outlane Extra Ball (E AU50) provides the number of times

Hole Extra Ball (E AU51) provides the number of times

Million Lit (E AU52) provides the total number of times MILLIONS was lit by spelling out the individual letters.

Million Awards (E AU53) provides the total number of times the MILLIONS feature was awarded.

Mystery Active (E AU54) provides the total number of times the Mystery Feature was activated.

Mystery 500,000 (E AU55) provides the total number of times the Mystery Feature awarded 500,000 points.

Mystery Catch-Up (E AU56) provides the total number of times the Mystery Feature awarded

Mystery Double (E AU57) provides the total number of times the Mystery Feature Doubled your score.

Mystery Extra Ball (E AU58) provides the total number of times the Mystery Feature awarded an Extra BALL.

Mystery Bonus Hold (E AU59) provides the total number of times the Mystery Feature awarded Bonus Hold.

Mystery 5X (E AU60) provides the total number of times the Mystery Feature awarded 5X Bonus

2 Ball Multiball (E AU61) provides the total number of times 2 Ball Multiball was achieved.

3 Ball Multiball (E AU62) provides the total number of times 3 Ball Multiball was achieved.

Locked Left (E AU63) provides the total number of times a ball was locked in the left hole.

Locked Center (E AU64) provides the total number of times a ball was locked by the Center Lock shot.

Locked Right (E AU65) provides the total number of times a ball was locked in the right hole.

Tower Left (E AU66) provides the total number of times the left Tower value was collected.

Tower Center (E AU67) provides the total number of times the Center Tower value was collected.

Tower Right (E AU68) provides the total number of times the Right Tower value was collected.

Jackpot Lit (E AU69) provides the total number of times was lit by completing the Bowling Pin Targets during 3 Ball Multiball.

Jackpot 1,000,000 (E AU70) provides the total number of times the Jackpot value collected was between 1.00 and 1.99 Million points.

Jackpot 2,000,000 (E AU71) provides the total number of times the Jackpot value collected was between 1.00 and 1.99 Million points.

Jackpot 3,000,000 (E AU72) provides the total number of times the Jackpot value collected was between 1.00 and 1.99 Million points.

Jackpot 4,000,000 (E AU73) provides the total number of times the Jackpot value collected was over 4 Million points.

Right Bank 50,000 (E AU74) provides the total number of times the Right Target bank awarded 50,000 points.

Right Bank Bonus Hold (E AU75) provides the total number of times the Right Target bank awarded Bonus Hold.

Right Bank Extra Ball (E AU76) provides the total number of times the Right Target bank awarded an Extra Ball.

Right Bank Special (E AU77) provides the total number of times the Right Target bank awarded a Special.

Right Bank 100,000 (E AU78) provides the total number of times the Right Target bank awarded 100,000 points.

Laser Lit (E AU79) provides the total number of times the Laser Kick is enabled by one of the following:

- 1.) At the beginning of each released new ball.
- 2.) Then by striking the Flashing Chocolate Target.
- 3.) Then by completing all the Flashing Chocolate Targets.
- 4.) Then by completing all the Flashing Chocolate Targets in sequence.

Laser Kicked (E AU80) provides the total number of times the Laser Kick was operated.

Ramp Shots (E AU81) provides the total number of completed Ramp Shots.

Notes

GAME ADJUSTMENTS

GENERAL

There are 48 adjustable functions provided to vary difficulty of play and to periodically reset audits and the high score levels. The various game adjustments are summarized in the **Game Adjustments Table** and, when accessed, are shown on the player score displays. The *Adjustment Number* is shown in the Player 3 Display, the *Description* in the Player 1 and 2 Displays, and the setting in the Player 4 Display. Access and control is provided from switches located on the inside of the coin door.

Game adjustments are accessed from the audit mode. With the audits displaying game identification and the FORWARD/REVERSE switch in the REVERSE (down) position, depress the STEP switch and E Ad48 (Expanded Adjustment 48) is shown in the Player 3 display, FACTORY RESTORE is shown in the Player 1 & 2 displays, and OFF is shown in the Player 4 display. With the audits displaying AU09 (or expanded E AU81) and the FORWARD/REVERSE switch in the FORWARD (up) position, depress the STEP switch and Ad01 is shown in the Player 3 display, REPLAY MANUAL/FIXED is shown in the Player 1 and 2 displays, and the setting is shown in the Player 4 display.

With the FORWARD/REVERSE switch in the FORWARD (up) position, depressing the STEP switch advances through the game adjustments one at a time. With it in the REVERSE (down) position, the STEP switch selects lower-numbered adjustments. To rapidly scroll through adjustments, hold the STEP switch depressed. Adjustment values are changed by operating the GAME START push-button. The FORWARD/REVERSE switch setting determines whether the values are increased or decreased. (With the FORWARD/REVERSE switch up, the value increases, with it down, the value decreases). When the STEP switch is depressed the Player 1 and 2 displays indicate REQUEST INSTALLED.

REPLAY AND GENERIC FEATURES

Replays may be adjusted either for fixed levels or for a system-adjusted manual percentage of replay awards. Four levels may be selected. Adjustments allow awarding of a credit or an extra ball as each level is exceeded. With the manual percentage feature, if the actual replay percentage is higher or lower than that desired, the game computes new recommended manual percentage score(s). When the coin door is subsequently opened the player displays indicate the recommended level and a sound is made to alert the operator of a potential change. This new level is entered into adjustments simply by pressing the game start push-button. (If the coin door is closed or you enter audits/adjustments or diagnostics, the replay level is not changed.)

REPLAYS (Ad 01 through 06)

Ad 01 Replay Manual/Fixed

- **Manual:** Adjust for percentage of awards for replay levels (1% through 50%). Proceed to Ad 02 and 03 for starting replay levels.
- **Fixed:** Lower the automatic value below 1% and Player 1 display indicates FIXED. Proceed to Ad 02 and 03 for fixed replay levels.

Ad 02 Start Replay

- **Manual:** Adjust the starting Replay 1 setting to between 100,000 and 99,900,000.

Ad 03 Levels Replay/Level 1,2,3 & 4 Replay

- Adjust the number of replay levels to be active (1 to 4). Any additional starting replay levels are automatically set to values higher than Replay 1
- Adjust Replay 1 level to between 100,000 and 99,900,000. (Same as Start Replay)
If Ad 03 is set for 2, adjust Replay 2 level to between 100,000 and 99,900,000.
If Ad 03 is set for 3, adjust Replay 3 level to between 100,000 and 99,900,000.
If Ad 03 is set for 4, adjust Replay 4 level to between 100,000 and 99,900,000.

Game Adjustment Table

Adjustment Number (Player 3)	Description (Players 1 & 2)	Factory Setting (Player 4)
Ad 01	Replay/Manual	10%
Ad 02	Start Replay	5,500,000
Ad 03	Levels Replay *	01
Ad 04	Game Awards	CREDIT
Ad 05	Limit Freegame	03
Ad 06	Limit Extraball	03
Ad 07	Game Rules	FACTORY
Ad 08	Coinage*	USA2
Ad 09	Game Cleaned	NO
Ad 10	Coin Reset	NO
Ad 11	Audits Reset	NO
Ad 12	Restore H.S.T.D.	NO
Ad 13	Expand Adjustments	NO
E Ad 14	Match Percent	08
E Ad 15	Balls/Game	03
E Ad 16	Warning Tilt	01
E Ad 17	Buy In Allowed	NO
E Ad 18	Replay Boost	NO
E Ad 19	Credits Limit	30
E Ad 20	Scores Highest	YES
E Ad 21	World Record Awards	03
E Ad 22	Todays 1 Award	01
E Ad 23	Todays 2 Award	00
E Ad 24	Todays 3 Award	00
E Ad 25	Backup World Record	9,000,000
E Ad 26	Backup Todays 1	8,000,000
E Ad 27	Backup Todays 2	7,000,000
E Ad 28	Backup Todays 3	6,000,000
E Ad 29	Backup Todays 4	5,000,000
E Ad 30	Backup Todays 5	4,000,000
E Ad 31	H.S.T.D. Every	700
E Ad 32	Clean Game Every	1500
E Ad 33	Free Play	NO
E Ad 34	Message Custom	ON
E Ad 35	Attract Mode Music	ON
E Ad 36	Flash Lamps	NORMAL
E Ad 37	Coils Pulse	NORMAL
E Ad 38	Outlane Toggle	BOTH
E Ad 39	Million Style	EASY
E Ad 40	Million Timer	FACTORY
E Ad 41	No Limit Million	NO
E Ad 42	Top Lane Million	YES
E Ad 43	Recall Top Lane	YES
E Ad 44	Right Bank Option	HARD
E Ad 45	Lock Lit	FACTORY
E Ad 46	Lock Timer	FACTORY
E Ad 47	Tower Action	NO
E Ad 48	Factory Restore	NO

* Some settings result in Drop-Down Tables- See Text

Ad 04 Game Awards Set for replays to award: **CREDIT, EXTRA BALL, TICKET** or **AUDIT** (no award but recorded in the audit totals).

Ad 05 Limit FreeGame - Adjust for the maximum number of free games that may be accumulated per game; 0 to 9.

Ad 06 Limit Extra Balls - Adjust for the maximum number of extra balls that may be accumulated per game; 1 to 9 or OFF.

SINGLE-FUNCTION DIFFICULTY ADJUSTMENT (Ad 07)

Any one of five INSTALL settings for this adjustment may be activated to automatically select settings for multiple adjustments affecting game difficulty. Use the Start button to choose the difficulty level you require and press the step button to activate the setting. After activation, the individual adjustments may be readjusted if desired. Refer to Install Adjustment Table for details.

Ad 07 Game Rules - Set to **EXTRA EASY, EASY, FACTORY, HARD** or **EXTRA HARD**.

Install Adjustment	E Ad07 Extra Easy	E Ad07 Easy	E Ad07 Factory	E Ad07 Hard	E Ad07 Extra Hard
E Ad 38 Outlane Toggle	FLIPPER	FLIPPER	BOTH	SLING	SLING
E Ad 39 Million Style	EASY	EASY	EASY	FACTORY	HARD
E Ad 40 Million Timer	EXEASY	EASY	FACTORY	HARD	EXHARD
E Ad 41 No Limit Million	YES	YES	NO	NO	NO
E Ad 42 Top Lane Million	YES	YES	YES	NO	NO
E Ad 43 Recall Top Lane	YES	YES	YES	YES	NO
E Ad 44 Right Bank Options	EASY	EASY	HARD	HARD	HARD
E Ad 45 Lock Lit	EASY	EASY	FACTORY	FACTORY	HARD
E Ad 46 Lock Timer	EXEASY	EASY	FACTORY	HARD	EXHARD
E Ad 47 Tower Action	YES	YES	NO	NO	NO

NOVELTY / 5-BALL/ADD-A-BALL SETTINGS

The following three combinations are recommended for situations where local laws restrict certain game features regarding the use of replays or the number of balls per game:

Novelty Play Rules - Set to establish recommended settings for no free play or extra balls:

Ad 01 Manual Replay = Fixed
 Ad 02 Start Replay = 00
 Ad 03 Levels Replay = None
 Ad 04 Game Awards = None
 Ad 05 Limit Freegame = 0

Ad 06 Limit Extra Balls = 0
 E Ad 14 Match Percent = Off
 E Ad 20 World Record Awards = 0
 E Ad 21-23 Todays 1-3 Awards = 0

5-Ball Play Rules - Set to establish recommended settings for 5-ball play:

Ad 01 Manual Replay = 07%
 Ad 02 Replay Start = 7,000,000
 Ad 03 Replay Levels = 01
 Ad 04 Game Awards = Credit
 Ad 05 Limit Freegame = 3
 Ad 06 Limit Extra Balls = 3

E Ad 14 Match Percent = 04
 E Ad 15 Balls/Game = 5
 E Ad 20 World Record Awards = 3
 E Ad 21 Todays 1 Award = 1
 E Ad 38 Outlane Toggle = Flipper
 E Ad 39 Million Style = Hard

E Ad 40 Million Timer = Hard
 E Ad 41 No Limit Million = No
 E Ad 42 Top Lane Million = Yes
 E Ad 43 Recall Top Lane = No
 E Ad 44 Right Bank Options = Hard
 E Ad 46 Lock Timer = Hard

Extra Ball Settings-To disable awarding of credits and provide awards with an extra ball make the following adjustments:

Ad 04 Game Awards = Extra Ball
 Ad 05 Limit Freegame = 0

E Ad 14 Match Percent = OFF
 E Ad 19 Scores Highest = No

E Ad 20 to 23 World Record & Todays High Awards = 0

GAME PRICING (Ad 08)

There are two methods available for coin switch programming; Standard and Custom. Standard pricing uses a single adjustment (Ad 08) to select a pricing scheme shown in the **Standard /CustomPricing Table**. Custom pricing is used to select additional pricing schemes defined by a Drop Down menu .

With Ad 08 set to **CUSTOM** operating the step button again initiates a drop down menu representing coin switch pulses for the left, right, and center coin slots. The prescribes the number of pulses required for one credit. For example, if *Left Coin Pulses*, was set to 02 and *Coin Switch Pulses Required for 1 Credit*, to 01 a coin in the left slot would produce two credits. Further, if *Left Coin Pulses*, was set to 01 and *Coin Switch Pulses Required for 1 Credit*, to 02, two coins in the left slot would be required for one credit.

Coin Switch Pulses Required for Bonus Credit may be set to post bonus credits when a minimum amount of coins are inserted at one time. For example, if *Left Coin Pulses* was set to 01, *Coin Switch Pulses Required for 1 Credit* to 01 and *Coin Switch Pulses Required for Bonus Credit* to 04, one credit would be posted for each of the first three coins in the left slot and two credits for the fourth coin.

Standard/Custom Pricing - Set for the desired pricing scheme from the Standard Pricing Table as indicated in the Player 1 and 2 displays. For Custom Pricing, set to **CUSTOM**. When set to CUSTOM, the following adjustments are utilized to tailor each individual coin chute.

Left Coin Switch Pulses - Set the number of pulses registered for closure of the left coin switch; 00 to 99.

Right Coin Switch Pulses - Set the number of pulses registered for closure of the right coin switch; 00 to 99.

Center Coin Switch Pulses - Set the number of pulses registered for closure of the center coin switch; 00 to 99.

Coin Switch Pulses Required for 1 Credit - Set the number of coin switch pulses required to post one credit; 00 to 99.

Coin Switch Pulses Required for Bonus Credit- Set the number of coin switch pulses required to award a bonus credit; 00 to 99.

CUSTOM PRICING TABLE

Coin Mechs			Plays/Coins	Adjustments					
Left	Right	Center		Ad08	Left P	Right P	Mid P	Pulse/1Cr	Puls/bon
25¢	25¢	\$1.00	1/25¢ 3/50¢	Custom	01	01	04	01	02
			1/25¢ 5/\$1.00	Custom	01	01	04	01	04
			1/25¢/ 6/\$1.00	Custom	05	05	20	04	20
5SCH	10SCH	10SCH	1/10 SCH	Custom	01	02	02	02	00
			1/10 SCH 4/30SCH	Custom	04	08	08	06	00
20¢	\$1.00	--	1/20¢	Custom	01	05	00	01	00
			1/60¢ 2/\$1.00	Custom	01	05	00	03	05
10P	10P	50P	1/10P 6/50P	Custom	01	01	05	01	05
			1/20P 3/50P	Custom	01	01	05	02	05

STANDARD PRICING TABLE

Ad 08 Standard Pricing Select			Coin Mechs			Plays/Coins		
			Left	Center	Right	Left	Center	Right
1	2	4						
USA1	1COIN	1PLAY	25¢	\$1.00	25¢	1 PLAY/ 1COIN	4 PLAY/ 1COIN	1 PLAY/ 1COIN
USA2	4 COINS	3PLAYS	25¢	\$1.00	25¢	1 PLAY/ 2COIN 2 PLAY/ 3COIN 3 PLAY/ 4COIN	3 PLAY/ 1COIN	1 PLAY/ 2COIN 2 PLAY/ 3COIN 3 PLAY/ 4COIN
USA3	2 COINS	1 PLAY	25¢	\$1.00	25¢	1 PLAY/ 2COIN	2 PLAY/ 1COIN	1 PLAY/ 2COIN
USA4	2COINS	1 PLAY 1COIN BUY-IN	25¢		25¢	2 COINS FOR THE 1st PLAY 1PLAY/ 1 COIN ONLY DURING BUY-IN		
AUSTRIA COINAGE			5 SCH	10 SCH	10SCH	1 PLAY/ 2COIN 2 PLAY/ 3COIN 3 PLAY/ 4COIN	2 PLAY/ 1COIN 3 PLAY/ 2COIN	2 PLAY/ 1COIN 3 PLAY/ 2COIN
AUSTRALIA COINAGE			20¢	\$1.00	\$2.00	1 PLAY/ 3COIN	2 PLAY/ 1 COIN	4 PLAY/ 1COIN
UK COINAGE			10P	50P	£1	1 PLAY/ 3COIN	2 PLAY/ 1COIN	5 PLAY/ 1COIN
SWISS 1 SWISS 2			1 SFR	2 SFR	5 SFR	Same as German 1 Same as German 2		
BELGIUM COINAGE			20f	50f	20f	1 PLAY/ 1COIN	3 PLAY/ 1COIN	1 PLAY/ 1COIN
GERMAN 5DM 1			1DM	2DM	5DM	1 PLAY/ 1COIN 7 PLAY/ 5COIN	2 PLAY/ 1COIN 8 PLAY/ 3COIN	7 PLAY/ 1COIN
GERMAN 5DM 2			1DM	2DM	5DM	1 PLAY/ 1COIN 3 PLAY/ 2COIN 5 PLAY/ 3COIN 7 PLAY/ 4COIN 9 PLAY/ 5COIN	3 PLAY/ 1COIN 7 PLAY/ 2COIN 10 PLAY/ 3COIN 14 PLAY/ 4COIN	9 PLAY/ 1COIN
NETHERLAND COINAGE			1 Guilder	1 Guilder	2.5Guilder	1 PLAY/ 1COIN	1 PLAY/ 1COIN	3 PLAY/ 1COIN
SWEDEN COINAGE			1KR	5KR	5KR	1 PLAY/ 3COIN 2 PLAY/ 5COIN	2 PLAY/ 1COIN	2 PLAY/ 1COIN
FRANCE 1 COINAGE			1f	5f	10f	1 PLAY/ 3COIN 2 PLAY/ 5COIN	2 PLAY/ 1COIN	5 PLAY/ 1COIN
FRANCE 2 COINAGE			1f	5f	10f	1 PLAY/ 5COIN	1 PLAY/ 1COIN	3 PLAY/ 1COIN
ITALY COINAGE			500L		500L	1 PLAY/ 1COIN		1 PLAY/ 1COIN
SPAIN COINAGE			25P		100P	1 PLAY/ 1COIN		5 PLAY/ 1COIN
JAPAN COINAGE					100¥			1 PLAY/ 1COIN 3 PLAY/ 2COIN

ADDITIONAL GENERIC FEATURES

Ad 09 Game Cleaned - When enabled (set to **YES**) the game cleaning counter will be reset to zero and Game Clean-Me Green light will go out when STEP is depressed. (Also see E Ad31.)

Ad 10 Coin Reset - When enabled (set to **YES**) all coin and paid credit totals will be reset to zero when STEP is depressed.

Ad 11 Audits Reset - When enabled (set to **YES**) all audit totals except for coins and paid credits will be reset to zero when STEP is depressed.

Ad 12 Restore High Score - When enabled (set to **YES**) the High Score Levels and associated initials will be restored to backup settings when STEP is depressed .

Ad 13 Expand Adjustments - When set to **NO**, depressing the STEP push-button advances directly to E Ad 45, FACTORY RESTORE. When set to **YES**, depressing the STEP push-button sequences through the expanded adjustments. When exiting from expanded adjustments, this function is reset to **OFF** for the next time that adjustments are required.

E Ad 14 Match Percent- Set Match percent from **00%** to **10%** or **OFF**. At 00% the match display occurs at the end of the game but never awards a credit.

E Ad 15 Balls Per Game - Adjust the number of balls per game; **2** to **5**.

E Ad 16 Warning Tilt - Adjust the number of plumb bob tilt switch closures before the ball in play is tilted; **1** to **3** or **OFF**.

E Ad 17 Buy In Allowed- Set to **YES** or **NO**. Determines if starting another game immediately after the Match feature will retain accumulated lit playfield features.

E Ad 18 Replay Boost - Set to **YES** or **NO**. When set to **YES**, exceeding a replay will set a temporary replay level for each time a replay level is surpassed. This new level will equal the player's final score (when the replay was awarded) for each following game, until the replays have all been played. At this time the previous level is resumed.

E Ad 19 Credits Limit - Adjust the maximum number of credits that may be posted; **4** to **50**.

HIGH SCORE LEVELS (E Ad 19 through 30)

There are four of the six high score levels with associated player initials that are displayed during the attract mode. This provides a high-score-to-date feature. When players exceed these levels, the player initials may be entered to replace the previous ones. These levels may be adjusted to award credits and to be reset to backup values after a selected number of games.

E Ad 20 Scores Highest - Set to enable or disable the four high score levels; **YES** or **NO**.

E Ad 21 World Record - Adjust the number of credits awarded for exceeding level 1 (the highest of the four levels); **0** to **5**.

E Ad 22 Todays 1 Award- Adjust the number of credits awarded for exceeding level 1; **0** to **3**.

E Ad 23 Todays 2 Award - Adjust the number of credits awarded for exceeding level 2; **0** to **2**.

E Ad 24 Todays 3 Award - Adjust the number of credits awarded for exceeding level 3; **0** to **1**.

E Ad 25 Backup World Record - Adjust the score level to which the world record (the highest of the four levels) may be altered. This adjustment is not affected by E Ad30 (Factory Reset defaults to 7,500,000).

E Ad 26 Backup Todays 1 - Adjust the backup score level to which level 1 may be reset.

E Ad 27 Backup Todays 2- Adjust the backup score level to which level 2 may be reset.

E Ad 28 Backup Todays 3- Adjust the backup score level to which level 3 may be reset.

E Ad 29 Backup Todays 4- Adjust the backup score level to which level 4 may be reset.

E Ad 30 Backup Todays 5- Adjust the backup score level to which level 5 may be reset.

E Ad 31 High Score Reset Every - Adjust the number of games between automatic resets of high score levels to backup settings and ball time averager adjustments; 100 to 900 or OFF (no reset or adjustment).

E Ad 32 Clean Game Every- Adjust the number of games in which the Green Light turns on to indicate the playfield needs cleaning. Adjustable from 100 to 2000.

E Ad 33 Free Play - When set to YES, no coins are required for games.

E Ad 34 Message Custom - When desired, this function is used to establish a custom message periodically displayed during the attract mode. Set the feature to CHANGE using the Credit button and depress STEP. The letter A is indicated in the first position of the Player 1 display. Vary the letter by operating the left and right flippers. With the desired letter indicated, depress the CREDIT button to lock in the letter and advance to the next display character. Repeat this procedure until the desired message is indicated in the Player 1 and 2 displays. At this time, depress the STEP push-button switch to advance to E Ad 35.

NOTE

To lock in the custom message, the game must be returned to Game Over by depressing STEP with E Ad 48 displayed.

E Ad 35 Attract Mode Music - Set to ON (approximately every 3 minutes), or OFF.

E Ad 48 Factory Restore-Depressing STEP without changing the value shown in the Player 4 Display locks in any custom message set with E Ad 34 and returns the game to Game Over. Set the value to ON and depress STEP switch to revert all game adjustments to factory settings, clear the Custom Message and return to Game Over.

GAME SPECIFIC FEATURES (E Ad 36 TO E Ad 47)

E Ad 36 Flash Lamps- Set to NORMAL, DIM or OFF. When set to NORMAL the Flash Lamps are active, when DIM the Flash Lamps impulse power is reduced by 25% and when OFF the Flash Lamps do not flash.

E Ad 37 Coils Pulse- Set To NORMAL, HARD or SOFT. When HARD the coil pulse power is increased by 12.5% of the normal pulse rate. When set to SOFT the coil pulse power is reduced by 12.5% of the normal pulse rate. These adjustments are provided to compensate for Low Line or High Line voltage conditions where the solenoids appear to kicking too weak or too hard.

E Ad 38 Outlane Toggle- Set to FLIPPER, SLING or BOTH. This feature controls how the lit Outlane Special will alternate from the left lane to the right. When set to FLIPPER operating either flipper button will cause the Special light to move from one lane to the other. When set to SLING operating either Slingshot switch will cause the Special light to move from one lane to the other. When set to BOTH operating either the Flipper or Slingshot switches will cause the Special light to move from one lane to the other.

E Ad 39 Million Style- Set to EASY, FACTORY or HARD. When set to EASY, all the lit letters in MILLION are carried over in memory from player to player, game to game. When set to FACTORY, all the lit letters in MILLION carried over individually for each player from ball to ball. When Set to HARD, all the lit letters in MILLION reset at the end of each ball.

E Ad 40 Million Timer- Set to **EXEASY, EASY, FACTORY, HARD** or **EXHARD**. Determines how long the **MILLIONS** feature remains enabled in seconds. Each time the feature is reenabled in the same game, the starting timer decreases by 2 x (number of Millions Awarded) down to a minimum of 5 seconds

Million Timer Setting	Seconds
Extra Hard	10
Hard	12
Factory	14
Easy	16
Extra Easy	18

E Ad 41 No Limit Million- Set to **YES** or **NO**. When set to **YES**, each ramp shot completed during the **MILLION** countdown awards 1,000,000 points. When set to **NO**, only the first ramp shot completed during the **MILLION** countdown awards 1,000,000 points.

E Ad 42 Top Lanes Million- Set to **YES** or **NO**. When set to **YES**, completing the 3 Top Lanes, lights a letter in the word **MILLIONS**.

E Ad 43 Recall Top Lane- Set to **YES** or **NO**. When set to **YES**, all lit Top Lanes will be carried over from ball to ball for each individual player.

E Ad 44 Right Bank Option- Set to **EASY** or **HARD**. When set to **EASY**, each time the Right Drop Target Bank is completed will enable a playfield award next to each Ball Lock (Bonus Hold, Extra Ball or Special). When set to **HARD**, each enabled award must be collected before completing the bank to enable the next award.

E Ad 45 Lock Lit- Set to **EASY,FACTORY** or **HARD**. When set to **EASY**, completing the Bowling Pin targets in any order will qualify the player to lock all 3 balls. When set to **FACTORY**, the targets may still be hit in any order but will only qualify the player to lock 2 balls. When set to **HARD**, the targets may still be hit in any order but will only qualify the player to lock 1 ball.

E Ad 46 Lock Timer- Set to **EXEASY, EASY, FACTORY, HARD** or **EXHARD**. Determines how long the Lock Feature remains enabled in seconds.

Lock Timer Setting	1st Time	2nd Time	3rdTime	4thTime	5thTime
Extra Hard	10	10	10	10	10
Hard	15	10	10	10	10
Factory	20	15	10	10	10
Easy	25	20	15	10	10
Ex tra Easy	30	25	20	15	10

E Ad 47 Tower Action- Set to **YES** or **NO**. When set to **YES**, a playfield animation takes place on a Tower Turbo Bumper every time the corresponding Tower bonus is increased. (Note: The tower bonus is increased by shooting the ball into a lock hole immediately after it rolls over a lit flipper return lane Switch)

GAME DIAGNOSTICS

The Data East Pinball system provides tests for sounds, digital displays, lamps, switches, and solenoids. Each feature may be tested manually or automatically using the STEP and FORWARD/REVERSE push-button switches inside the coin door and the Game Start push-button switch on the front of the cabinet. The automatic tests may be used for a quick verification of automatic test functions and the manual tests, for troubleshooting.

During game play, activation of switches and operation of coils with associated switches are monitored. If a switch is not made for 50 games it is considered bad. When operation of a coil should close or open a switch and does not, the coil is considered bad. In Game over attract mode, bad switches and coils (if any) are reported (See Tech Alert Description below). Note that reporting of an unused switch does not constitute a problem and that a bad coil could mean that the associated switch requires adjustment.

Wiring to switches, solenoids and controlled lamps uses color-coded wires that basically follows a resistor color-code scheme for the eight rows and eight columns. During the switch tests and during the discrete lamp test, identification of the color of the row and column wires are indicated in the Player 3 & 4 Displays. For example, making the right coin switch during the Switch Test results in the switch functional name (RIGHT COIN) shown in the Player 1 and 2 Displays, the row (WH-YE) and column (GR-BR) wire color codes shown in the Player 3 display, and the switch number shown in the Player 4 display.

BK = Black
BR = Brown
RE = Red
OR = Orange
YE = Yellow

GR = Green
BL = Blue
VI = Violet
GY = Grey
WH = White

ENTERING DIAGNOSTICS

With the game in the game-over mode, open the coin door and make sure that the FORWARD/REVERSE push-button switch is set to REVERSE (down) and depress the STEP push-button switch. The Player displays will show the tollfree Customer Service number 1-800-KICKERS, that is 1-800-542-5377 (U.S. including Illinois) and the toll number (708) 345-7700 (Outside the United States). this indicates entry into game diagnostics.

Service Credits

With the phone number displayed depress the STEP push-button switch. The game now gives the technician the option of adding 1 to 5 service credits. These credits allow the technician to test-play the game without adding any counts to the coin audits (AU 01 & AU 05-AU 08). When the message appears, press and hold the Game Start pushbutton until the desired number of credits are shown on the display. Then press the step button again to add these credits to the game and enter Tech Alert. If no Service Credits are desired, press the step button with the initial message displayed.

Tech Alert

The player displays will now indicate if there are any Bad Switches (Switches that are closed, that should not be or switches that have not been activated in 50 games) it also indicates if the game requires cleaning, based on the number set in E Ad 32. It should also be noted that the Tech Alert works in conjunction with the RED " Tech Check" and GREEN "Clean me Lights" located under the Start Button on the front of the game.

The Following conditions may occur in Game Over Attract Mode.

Red light- ON Indicates a non critical switch (ie. Outlane switch) is either stuck or has not been closed for 50 games.

Red light- FLASHING Indicates a critical switch (ie. Drop Target switch) is either stuck or has not been closed for 50 games.

Green light- ON Indicates 1500 games (operator adjustable E Ad 32) have been played and playfield cleaning is recommended

Green light- FLASHING Indicates 2250 games (1.5 X E Ad 32) have been played and playfield cleaning is strongly recommended

The Red Light will go off automatically after the bad switch (s) have been repaired. To turn the Green Light off you must enter Game Cleaned Ad 09 and change its setting from NO to YES by depressing the start button. Doing so will reset the Clean Game counter to 0.

Burn-In Minutes

Pressing the step button while in Tech Alert mode will step game into Burn-In Mode(Factory use). At this stage pressing the game start button will cause the game to exercise all CPU I/O functions. This is provided to constantly exercise sounds, solenoids, etc... To stop the test press the start button again. Cumulative Burn-In minutes will be displayed. To reset Burn-In minutes to 00, you must perform a Audit Reset Ad 11 or a Factory Restore E Ad 48.

SOUND TESTS

The Data East Pinball sound system produces true digital stereo sound on left and right speakers and mono on a center speaker. During Sound tests, the bottom display shows the sound board circuit under test and the corresponding sounds are selected by operating the left and right flipper buttons to choose the circuit to be tested. Now press the start button to initiate the sound. Refer to the Sound Test Chart for the sound circuits displayed and the sounds produced.

The sound functions allow verification that all channels are functioning properly and that the speaker connections are correct. Speaker Phase Testing procedures follow for checking speaker connections.

SOUND TEST CHART

Auto/Manual Tests (Player 1 & 2)	Sounds Produced
LEFT SPEAKER	Left Sine (Left Speaker Only)
CENTER SPEAKER	Center Sine (All speakers)
RIGHT SPEAKER	Right Sine (Right Speaker Only)
VOICE ROM1 (Loc F6)	"...The Simpsons....."
VOICE ROM2 (Loc F4)	"Hey Man, we're both under-achievers"
MUSIC TEST (Sound ROM Loc F7)	Level 1 Through Level 4 Music

Speaker Phase Testing

Connections to each of the three speakers are polarized and each must be connected appropriately for the best quality sound. If one speaker has the positive and negative connections reversed with respect to the other two, bass frequencies will not be produced properly and the overall sound quality will be poor.

To test for proper speaker phasing, use the sound test to cycle through the Left, Center, and Right Sine functions. If the Center Sine produces more volume and bass than the Left and Right Sines, the speakers are connected properly. If it produces the same or less, one speaker is connected improperly. To isolate and correct reversed speaker connections, one of two methods may be used.

1. Check each speaker for polarity markings. If the speakers have polarity markings, verify that the single-color wire (BLK, YEL or RED) is connected to the negative (-) terminal.
2. Disconnect the speaker output connector from the Sound Board and connect a 1.5-volt battery across each speaker pair one at a time while observing the speakers. Make sure that the positive battery terminal is connected to the positive lead (CN1-pin 1, 3, or 6) each time. As the connection is made, check speaker cone movement; proper connections are indicated by outward movement.

DIGITAL DISPLAY TEST

Digital displays are driven by digit and segment driver circuits. Digit drivers sequentially select individual character positions for both displays (Player 1 and 2 display) and (Player 3 and 4 display). Segment drivers (16 for Player 1 and 2 characters; 16 for Player 3 and 4 characters) select the individual segments of each position.

Automatic Test

To enter Display tests, operate the STEP push-button switch from the Sound Manual test. The displays will illuminate all segments in a single digit and sequence that digit from left to right in the Top Display and right to left in the Bottom Display. When each digit completes its cycle to the end of the display it reverses direction.

Switches

Switches are configured in an 8 x 8 matrix of columns (switch drives) and rows (switch returns) with up to 64 switches possible. The switch tests include three parts; switch test, active switches, and bad switches. Row and column wire colors are indicated in each test using corresponding resistor color code numbers.

Switch Test

From the Display Manual test, operate STEP push-button switch. Player 1 and 2 displays indicate SWITCH TEST. Close each switch and observe the displays. The Player 1 and 2 displays will indicate the switch name, the Player 3 display indicates the row and column wire colors, and the Player 4 display indicates the switch number. When a switch is released, the name and number disappear until another switch is closed or the test is exited.

Active Switches

Operate the STEP push-button switch from the Switch Test. Player 1 and 2 Displays indicate ACTIVE SWITCHES. If any switches are stuck closed (or made from the presence of a ball), the Player 1 and 2 displays sequence through switch names, the Player 3 display indicates the row and column wire colors, and the switch numbers are indicated in the Player 4 display. This cycle continues until all switches are cleared or until the STEP push-button switch is depressed.

SWITCH MATRIX CHART

ROW \ COLUMN	1 Q55 GRN-BRN CN8-1	2 Q54 GRN-RED CN8-2	3 Q53 GRN-ORN CN8-3	4 Q52 GRN-YEL CN8-4	5 Q51 GRN-BLK CN8-5	6 Q50 GRN-BLU CN8-7	7 Q49 GRN-VIO CN8-8	8 Q48 GRN-GRY CN8-9
1 WHT-BRN CN10-9	Plumb Tilt 1	Not Used 9	Left Outlane 17	Chocolate 25	Center D.T. Left 33	Right Bank 1 Top 41	Top Lane Right 49	Not Used 57
2 WHT-RED CN10-8	Not Used 2	Outhole 10	Left Return 18	Double Chocolate 26	Center D.T. 34	Right Bank 2 42	Top Lane Center 50	Not Used 58
3 WHT-ORN CN10-7	Credit Button 3	Trough #1 Left 11	Right Outlane 19	Triple Chocolate 27	Center D.T. Right 35	Right Bank 3 43	Top Lane Left 51	Not Used 59
4 WHT-YEL CN10-6	Right Coin 4	Trough #2 Center 12	Right Return 20	Left Lock 28	Spinner 36	Right Bank 4 44	Not Used 52	Not Used 60
5 WHT-GRN CN10-5	Center Coin 5	Trough #3 Right 13	Left Slingshot 21	Center Lock Bottom 29	Right Lock 37	Right Bank 5 Bottom 45	Multiball Start 53	Not Used 61
6 WHT-BLU CN10-3	Left Coin 6	Shooter Lane 14	Right Slingshot 22	Center Lock Top 30	Ramp Entrance 38	Left Turbo Bumper 46	Not Used 54	Not Used 62
7 WHT-VIO CN10-2	Slam Tilt 7	Left EOS 15	Not Used 23	Not Used 31	Ramp Exit 39	Center Turbo Bumper 47	Not Used 55	Not Used 63
8 WHT-GRY CN10-1	Not Used 8	Right EOS 16	Not Used 24	Not Used 32	Not Used 40	Right Turbo Bumper 48	Not Used 56	Not Used 64

Number	Description	Part No.	Number	Description	Part No.
01*	Plumb Tilt	See Cabinet	10	Out Hole	180-5011-00
02	Not Used	--	11	Trough #1(Left)	180-5009-00
03	Credit Button	500-5097-02	12	Trough #2(Center)	180-5009-00
04*	Right Coin	180-5024-00	13	Trough #3(Right)	180-5010-00
05*	Center Coin	180-5024-00	14	Shooter Lane	500-5143-00
06*	Left Coin	180-5024-00	15	Left Flip. Cab. Switch	180-5067-00
07*	Slam Tilt	180-5022-00	16	Right Flip.Cab. Switch	180-5067-00
08	Not Used	--	17	Left Outlane	515-5138-00
09	Not Used	--	18	Left Return Lane	515-5138-00
			19	Right Outlane	515-5138-00
			20	Right Return Lane	500-5142-00
			21	Left Slingshot Sw. (2)	180-5054-00
			22	Right Slingshot Sw. (2)	180-5054-00
			23	Not Used	-
			24	Not Used	-
			25	Chocolate	515-5162-08
			26	Double Chocolate	515-5162-08
			27	Triple Chocolate	515-5162-08
			28	Left Lock	180-5027-00
			29	Center Lock Bottom	180-5063-00
			30	Center Lock Top	180-5051-00
			31	Not Used	-
			32	Not Used	-
			33	Center D.T. Left	180-0030-00
			34	Center D.T. Center	180-0030-00
			35	Center D.T. Right	180-0030-00
			36	Spinner	500-5193-00
			37	Right Lock	180-5063-00
			38	Ramp Entrance	180-5010-00
			39	Ramp Exit	500-5287-00
			40	Not Used	-
			41	Right Bank 1 (Top)	180-5025-01
			42	Right Bank 2	180-5025-01
			43	Right Bank 3	180-5025-01
			44	Right Bank 4	180-5025-01
			45	Right Bank 5 (Bot.)	180-5025-01
			46	Left Turbo Bumper	180-5015-00
			47	Center Turbo Bumper	180-5015-00
			48	Right Turbo Bumper	180-5015-00
			49	Top Lane Right	515-5138-00
			50	Top Lane Center	515-5138-00
			51	Top Lane Left	515-5138-00
			52	Thru 64 Not Used	

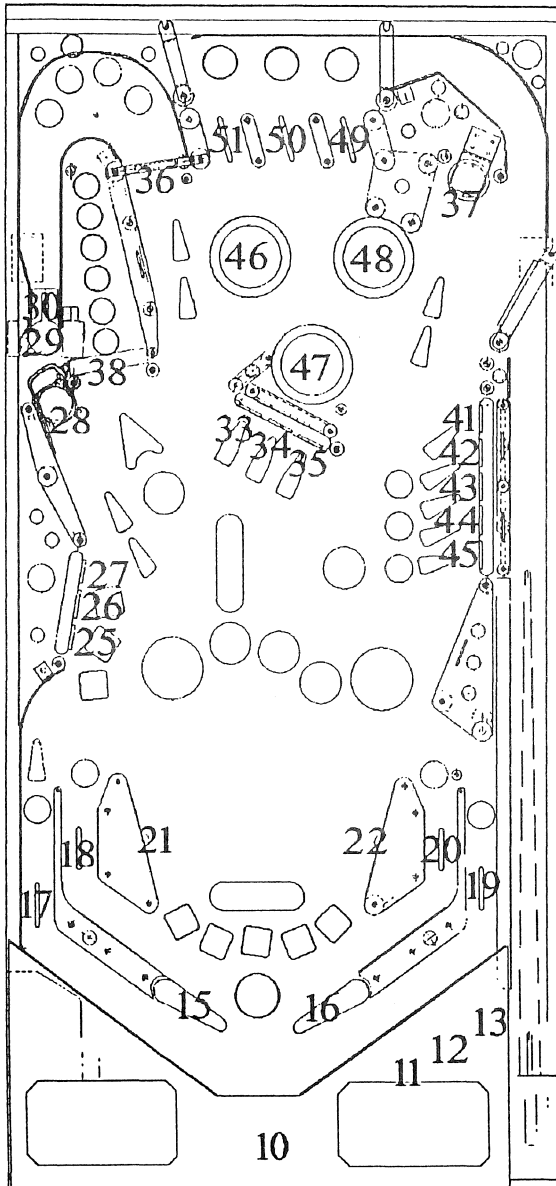

Switch Locations

*INDICATES CABINET SWITCHES.

LAMP TESTS

Controlled lamps are configured in an 8 x 8 matrix of columns (lamp drives) and rows (lamp returns) with up to 64 lamps possible. The lamp tests include four parts, all lamps, lamp return (row), lamp drive (column), and discrete (individual) lamps. Row and column wire colors are indicated in the discrete lamp test using corresponding resistor color code numbers.

All Lamps

From the Active Switch test, operate the STEP push-button switch. Player 1 and 2 displays indicate ALL LAMPS and all controlled lamps will light.

Lamp Returns

From the ALL LAMPS test, depress the STEP push-button switch. The top display indicates LAMP RETURNS and the Bottom display indicates wire color and the LAMP RETURN driver transistor. All controlled lamps in row 1 should be lit. Operating the Game Start push-button switch cycles through each of the rows separately.

Lamp Drives

From the LAMP RETURNS test, depress the STEP push-button switch. The Top display indicates LAMP COLUMNS and the bottom display indicates wire color and the LAMP DRIVES driver transistor. All controlled lamps in column 1 should be lit. Operating the Game Start push-button switch, cycles through each of the columns separately.

Single Lamp

From the LAMP DRIVES test, depress the STEP push-button switch. The top display indicates lamp name. The bottom display indicates the row and column wire colors and the lamp matrix number. Lamp 01 should light. With the FORWARD/REVERSE push-button switch in the FORWARD (up) position, operating the Game Start push-button switch selects higher-numbered lamps; with it in the REVERSE (down) position, Game Start selects lower-numbered lamps.

LAMP MATRIX CHART

ROW \ COLUMN	1 Q71 YEL-BRN CN7-1	2 Q70 YEL-RED CN7-2	3 Q69 YEL-ORN CN7-3	4 Q68 YEL-BLK CN7-4	5 Q67 YEL-GRN CN7-6	6 Q66 YEL-BLU CN7-7	7 Q65 YEL-VIO CN7-8	8 Q64 YEL-GRY CN7-9
1 Q72 RED-BRN CN6-1	Left Turbo Bumper 1	Chocolate 9	MILLIONS 17	Arrow Bonus Hold 25	6x 33	Outlane Left 41	Ramp Mystery 49	Right Bank 1 Top 57
2 Q73 RED-BLK CN6-2	Center Turbo Bumper 2	Double Chocolate 10	MILLIONS 18	Left Lock 26	5x 34	Return Right 42	Mystery Bonus Hold 50	Right Bank 2 58
3 Q74 RED-ORN CN6-3	Right Turbo Bumper 3	Triple Chocolate 11	MILLIONS 19	Arrow Special 27	4x 35	Return Left 43	Ramp Jackpot 51	Right Bank 3 59
4 Q75 RED-YEL CN6-5	Mystery 5X 4	Mystery Double Score 12	MILLIONS 20	Center Lock 28	3x 36	Outlane Right 44	Clown 52	Right Bank 4 60
5 Q76 RED-GRN CN6-6	Top Lane Right 5	Mystery Extra Ball 13	MILLIONS 21	Arrow Extra Ball 29	2x 37	Jackpot 1M 45	Red Tech Alert 53	Right Bank 5 Bottom 61
6 Q77 RED-BLU CN6-7	Top Lane Center 6	Center Bank Left 14	MILLIONS 22	Right Lock 30	Bonus Held 38	Jackpot 2M 46	Green Cleaning 54	Right Bank Special 62
7 Q78 RED-VIO CN6-8	Top Lane Left 7	Center Bank Center 15	MILLIONS 23	Mystery Catch Up 31	Marge Hair 39	Jackpot 3M 47	Jackpot 55	Right Bank Ex. Ball 63
8 Q79 RED-GRY CN6-9	Shoot Again 8	Center Bank Right 16	MILLIONS 24	Laser Kick 32	Mystery Scores 500K 40	Jackpot 4M 48	Bart Right Bank 56	Right Bank Bon.Hld. 64

Lamp Number Description

- 01 Left Turbo Bumper
- 02 Center Turbo Bumper
- 03 Right Turbo Bumper
- 04* Mystery 5X
- 05 Top Lane Right
- 06 Top Lane Center
- 07 Top Lane Left
- 08 Shoot Again
- 09 Chocolate
- 10 Double Chocolate

- 11 Triple Chocolate
- 12* Mystery Double Scores
- 13* Mystery Extra Ball
- 14 Center Bank Left
- 15 Center Bank Center
- 16 Center Bank Right
- 17 **MILLIONS**
- 18 **MILLIONS**
- 19 **MILLIONS**
- 20 **MILLIONS**
- 21 **MILLIONS**
- 22 **MILLIONS**
- 23 **MILLIONS**
- 24 **MILLIONS**
- 25 Arrow Bonus Hold
- 26 Left Lock
- 27 Arrow Special
- 28 Center Lock
- 29 Arrow Extra Ball
- 30 Lock Right
- 31* Mystery Catch Up
- 32 Laser Kick
- 33 6X
- 34 5X
- 35 4X
- 36 3X
- 37 2X
- 38 Bonus Held
- 39 Marge Hair
- 40* Mystery Scores 500K
- 41 Outlane Left
- 42 Return Right
- 43 Return Left
- 44 Outlane Right
- 45* Jackpot 1M
- 46* Jackpot 2M
- 47* Jackpot 3M
- 48* Jackpot 4M
- 49 Ramp Mystery
- 50* Mystery Bonus Hold
- 51 Ramp Jackpot
- 52 Clown
- 53 Red Tech Alert
- 54 Green Cleaning
- 55 Jackpot
- 56 Bart Right Bank
- 57 Right Bank 1 Top
- 58 Right Bank 2
- 59 Right Bank 3
- 60 Right Bank 4
- 61 Right Bank 5 Bottom
- 62 Right Bank Special
- 63 Right Bank Extra Ball
- 64 Right Bank Bonus Hold

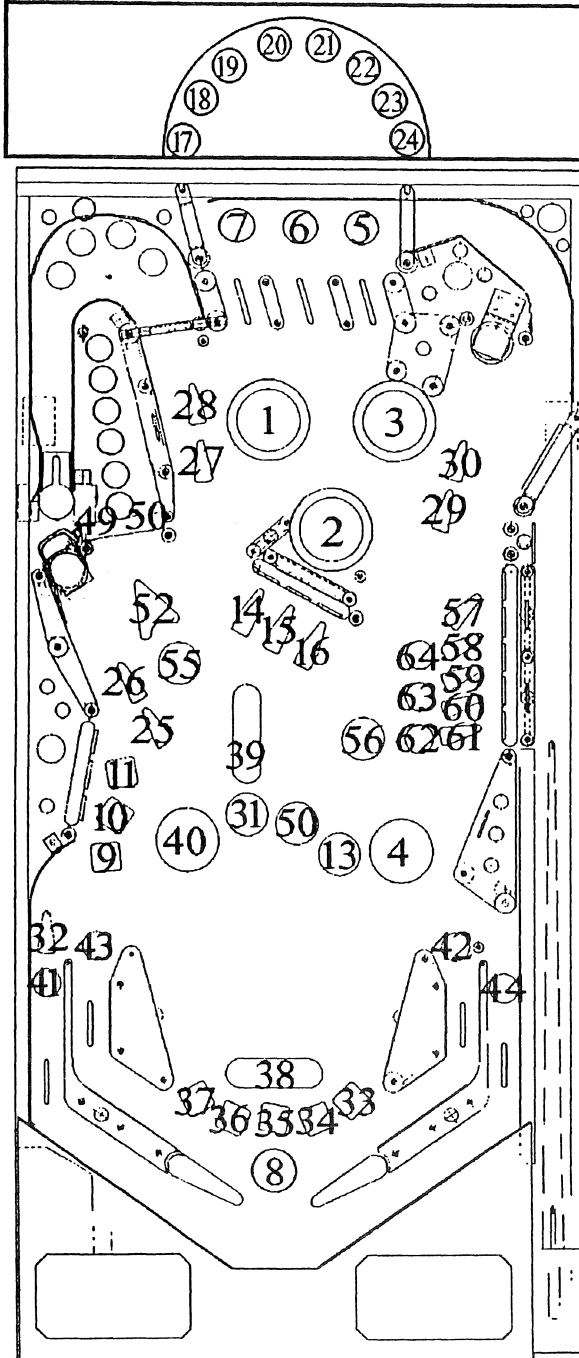

Lamp Locations

*Indicates Speaker or Backbox Lamp

FLASH LAMP COIL TESTS

Twenty-Two regular (pulsed under microprocessor control) coil drivers are provided to switch ground to coils. The Left/Right relay is used in conjunction with drives 1 through 8 to switch +32 volts between coils or flash lamps; these sets are termed "left" and "right". This relay is located on the PPB board which provides isolation diodes and current limiting resistors. This effectively provides 29 regular coils.

Flash Lamp

From the Single Lamp test, depress the STEP push-button switch. All Flash lamps will fire randomly. This allows the Technician to easily spot any burned out bulbs and replace them without stepping through the tests below.

Automatic Test

From the Flash Lamps test, depress the STEP push-button switch. Player 1 and 2 displays indicate ALL COILS. The test pulses each regular solenoid or flash lamp sequentially with the coil/flash lamp name indicated in the Player 1 and 2 displays and the wire colors in the Player 3 and 4 displays.

Select Coil

From the Coil Test, depress the STEP push-button switch. Player 1 and 2 displays indicate SELECT COIL and then the name of 1st drive, the wire colors are indicated in the Player 3 and 4 displays. Operate either Flipper push-button switch to select the coil or flash lamp to be tested. With the desired drive number indicated in the Player 4 display, depress the START push-button switch to cause it to be pulsed repeatedly.

RETURN TO GAME OVER

From the Select Coil test, depress the STEP push-button switch once. The game returns to the game-over mode.

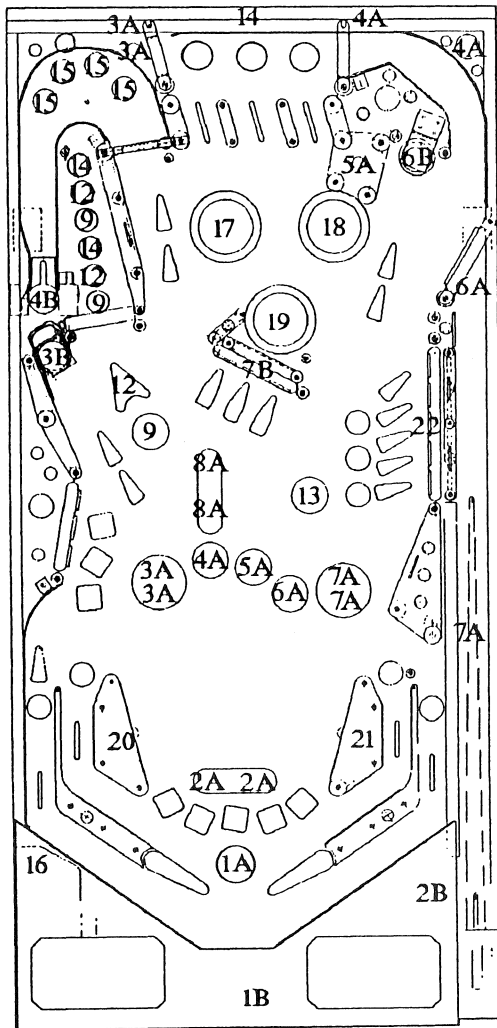

CPU Controlled Auxillary Solenoids

Coil Number	Coil Description	Control Line (CPU to Coil)	Power Line (PS to Coil)	Drive Transistor	Coil Type
18	Right Turbo Bumper	BLU-ORN CPU CN19-3	RED PS CN3-8	Q8	23-800
19	Center Turbo Bumper	BLU-RED CPU CN19-4	RED PS CN3-8	Q9	23-800
20	Left Slingshot	BLU-YEL CPU CN19-6	RED PS CN3-8	Q10	23-800
21	Left Turbo Bumper	BLU-BRN CPU CN19-7	RED PS CN3-8	Q11	23-800
22	Right Slingshot	BLU-GRN CPU CN19-8	RED PS CN3-8	Q12	23-800
23	NOT USED	CPU CN19-9	PS CN3-8	Q13	-

Flipper Solenoids

Coil Description	Flipper GND		Power Lines	Coil Type	Power Input
	CPU to Coil	Sw. to Flip.PCB	FlipPc to Coil		To Flip PCB
Left Flipper	ORN-GRY CPU CN19-2	BLU-GRY CN1-9	GRY-YEL CN2-1,2	23-900	BLK-WHT 50VDC
Right Flipper	ORN-VIO CPU CN19-1	BLU-VIO CN1-1	BLK-WHT CN1-1	23-900	GRY, GRY-GRN 8VAC

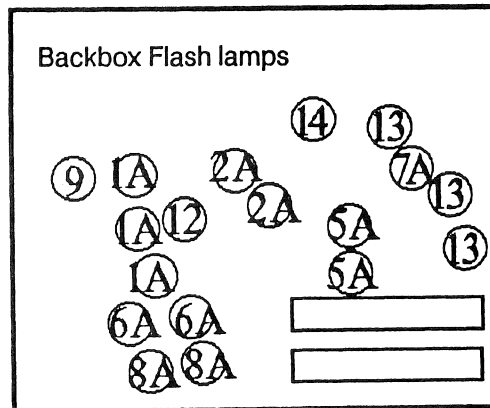

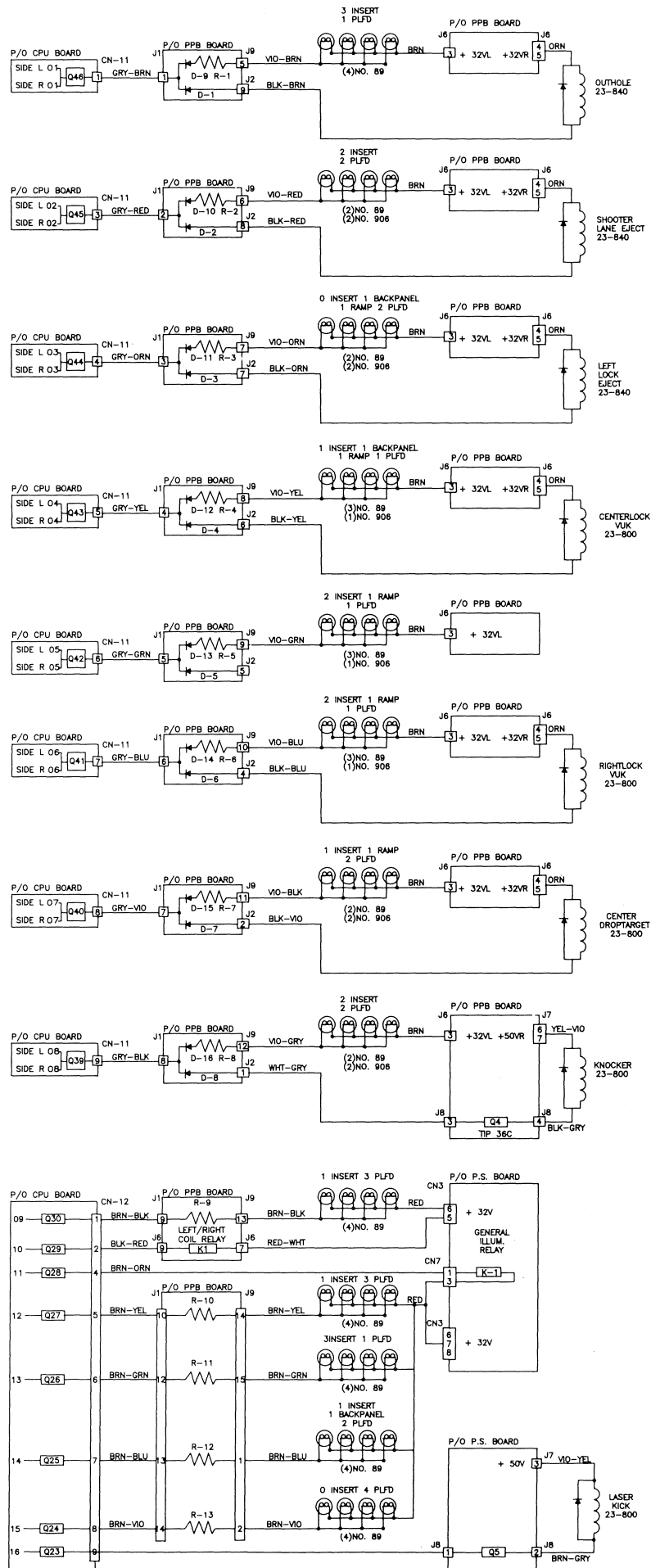

CABINET PARTS ILLUSTRATION

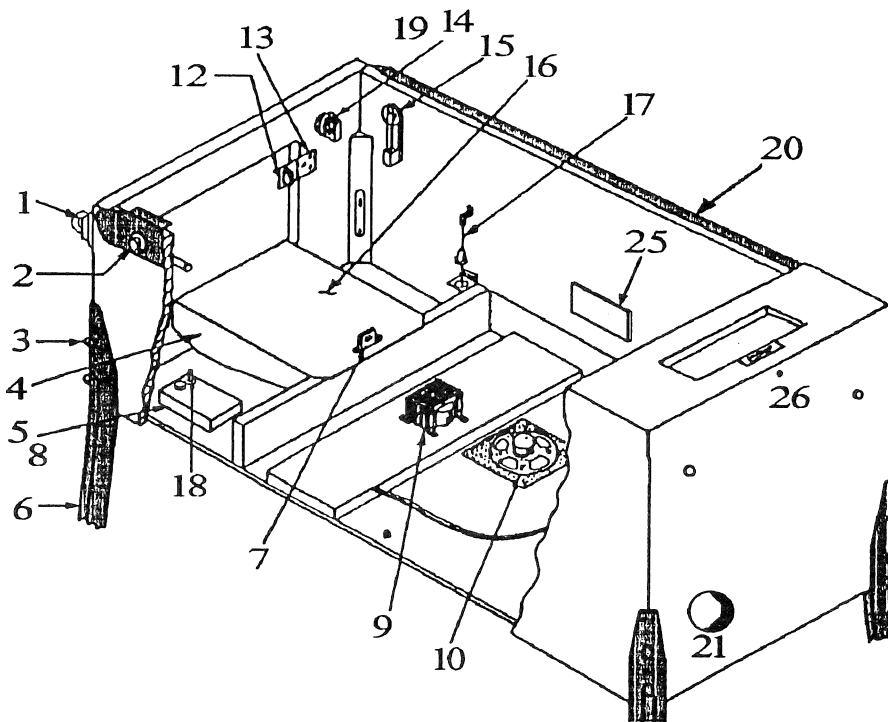

Item	Description	Part No.
1	Ball-shooter Assy	500-5019-14
2	Flipper Button	500-5026-18
3	Leg Bolt (Black)	231-5000-01
4	Cash Box Bottom	545-5090-00
5	On/Off Switch DP/ST	180-5001-00
6	Leg (Black)	535-5020-30
7	Lock Bracket-Cash Box	535-5215-00
8	Power Input Box Assy	515-5153-00-09
9	Transformer	010-5002-00
10	Speaker-Round (6")	031-5000-00
11	Side Armor-Right(Not Shown)	535-5010-31
12	Memory Protect Switch	180-5000-00
13	Memory Protect Switch Bracket	535-5225-00
14	Start Switch	500-5097-02
15	Flipper Micro Switch	180-5067-00
16	Cash Box Top	535-5013-01
17	Plumb Bob Tilt	535-5029-00
18	Volume Control	123-5000-00
19	Playfield Glass (Tempered)	660-5001-00
20	Side Armor -Left	535-5010-32
21	Recessed cup for Line cord	545-5122-00
22	Service Switch (Not Shown)	180-5012-00
23	Front Molding Lockdown Assy.	500-5020-00
24	Front Molding -Black (Not Shown)	500-5021-10
25	S.S.Flipper P.C.B.	520-5033-00
26	Roto Lock Bottom	355-5006-01

Playfield Parts

No.	Description	Part Number			
1.	1" Hex Spacer (2)	254-5008-06	19.	Shooter Lane Wire Gt Hat Brckt	535-5269-01
2.	2" Hex Spacer	254-5008-07	20.	Hat Bracket for Wire Gate (2)	535-5269-02
3.	P/F Eject Assembly	500-5051-06	21.	1" Wire Form (6)	535-5300-05
4.	Top Left Short Ball Guide	500-5270-00	22.	1 3/8" Wire Form	535-5300-16
5.	Top Left Long Ball Guide	500-5271-00	23.	Wire Gate	535-5307-01
6.	Top Right Short Ball Guide	500-5272-00	24.	Wire Gate	535-5307-02
7.	Laser Kick Out Lane Ball Guide	500-5273-00	25.	Flipper snubber Wires (2)	535-5373-01
8.	Pop Bumper Assemblies (3)	500-5275-00	26.	Spinner Actuator Wire	535-5387-00
9.	5 Bank Drop Target Assembly	500-5284-00	27.	Out/Return Lane Dividers (2)	535-5406-03
10.	Behind Left Eject Ball Deflector	500-5298-00	28.	Ball Catch Spring Wire	535-5611-00
11.	Ball Deflector Behind Right VUK	500-5299-00	*29.	Green Metal Ramp	535-5616-00
12.	Flipper Bat & Shaft (2)	515-5133-01	30.	Small Out/Return Lane Dividers (2)	535-5793-00
13.	3 Bank Stand Up Target Assmby	515-5152-08	31.	Ball Shooter Side Rail Guard	535-5795-00
14.	Spinner Target	515-5236-00	32.	Top Right Long Ball Guide	535-5904-00
15.	Bumper Post W/Thrded Top (4)	530-5007-00	*33.	Left Yellow Wire Ramp	535-5906-00
16.	Metal Standoff W/Groove (13)	530-5035-01	*34.	Red Mini Mars (2)	545-5004-02
17.	Metal Standoff W/Groove (2)	530-5035-02	*35.	Yellow Mini Mars (3)	545-5004-06
18.	Spinner Hat Bracket	535-5249-00	36.	Two Sided Ball Guide (2)	545-5011-06
			37.	One Sided Ball Guide (2)	545-5012-06
			38.	1 1/16" Yel.Rbbr. Jwld Post (22)	545-5013-06
			*39.	Red #44 Lamp Cover	545-5014-02
			*40.	Green #44 Lamp Cover	545-5014-04
			41.	Spinner Washers (2)	545-5037-00
			42.	P/F Eject Yellow Plastic Base	545-5060-06
			43.	Pop Bumper Cap (3)	545-5204-00
			44.	1 1/16" Yel.Dbl.Rbbr.Jwld Post (7)	545-5209-06
			45.	P/F Glass (Tempered)	660-5001-00
			46.	Bottom Arch Left Side Decal	820-5045-01
			47.	Bottom Arch Right Side Decal	820-5045-02
			*48.	Decal Sheet	820-5047-00
			*49.	Homer Mini Mars Decal	820-5048-00
			*50.	Marge Mini Mars Decal	820-5048-01
			*51.	Lisa Mini Mars Decal	820-5048-02
			*52.	Maggie Mini Mars Decal	820-5048-03
			*53.	Bart Mini Mars Decal	820-5048-04
			54.	3 Bank D.T. Left Tgt Decal	820-5115-00
			55.	3 Bank D.T. Center Tgt Decal	820-5115-01
			56.	3 Bank D.T. Right Tgt Decal	820-5115-02
			57.	5 Bank D.T. Top (1) Tgt Decal	820-5116-00
			58.	5 Bank D.T. 2 Tgt Decal	820-5116-01
			59.	5 Bank D.T. 3 Tgt Decal	820-5116-02
			60.	5 Bank D.T. 4 Tgt Decal	820-5116-03
			61.	5 Bank D.T. Bttm (5) Tgt Decal	820-5116-04
			62.	3 Bank Chocolate Decal	820-5117-00
			63.	3 Bank Double Chocolate Decal	820-5117-01
			64.	3 Bank Triple Chocolate Decal	820-5117-02
			65.	Front Spinner Decal	820-5211-01
			66.	Back Spinner Decal	820-5211-02
			67.	Pop Bumper Decal (3)	820-5311-00
			68.	P/F Mylar	820-5813-00
			69.	P/F Screened Plastic Set	830-5418-XX
			70.	Comp.Assmblid Plyfld.	505-6004-12-12
			71.	Wire Gate	535-5307-08

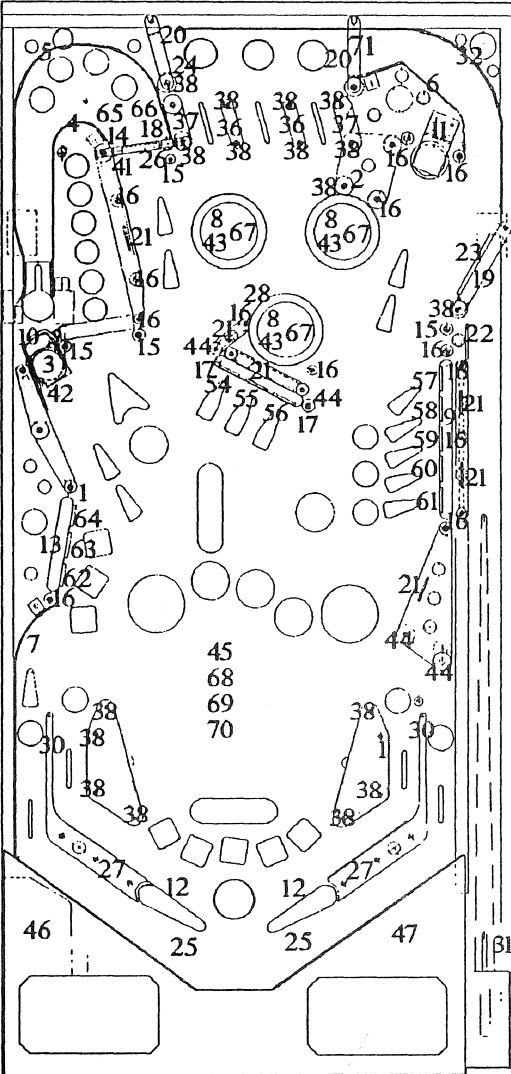

* Denotes not shown on drawing

BACKBOX PARTS ILLUSTRATION

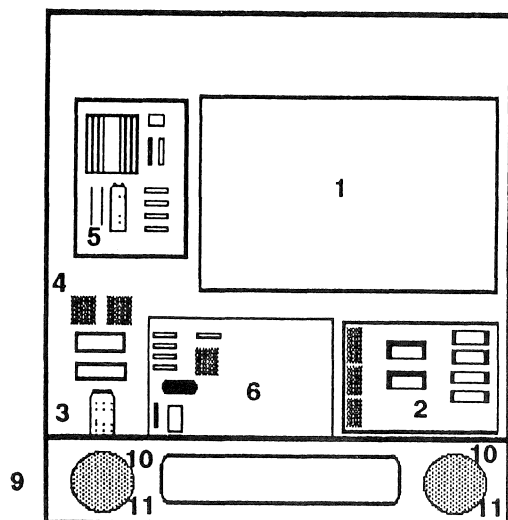

Item	Description	Part No.
1	CPU Board Assy.(Non-Reflex)	520-5003-03-12
2	Sound Board Assy	520-5002-03-12
3	Capacitor 2C1	125-5000-00
4	Bridge Rectifiers	112-5000-00
5	Power Supply Bd. Assy	520-5000-00
6	PPB Board	520-5021-02
7	Combined Display Bd Assy*	520-5030-00
8	Display Ribbon Cable*	036-5001-30
9	Speaker Housing	515-5217-00
10	Speakers (2)	031-5004-00
11	Speaker Grill (2)	830-5605-00
12	Back Box Glass*	830-5212-00
13	Roto-Lock Top*	355-5006-02

* Not Shown

RUBBER PARTS ILLUSTRATION

Item	Description	Part #
A.	3/16" (6)	545-5025-01
B.	5/16" (11)	545-5025-02
C.	1"	545-5025-05
D.	1 1/2" (4)	545-5025-07
E.	2"	545-5025-08
F.	2 1/2" (2)	545-5025-09
G.	3"	545-5025-10
H.	7/16" Outer Diameter	545-5025-17
I.	2 3/4" (3)	545-5025-20
J.	Rubber Post -Short(5)	545-5151-00
K.	Rubber Post -Tall(4)	545-5009-00
L.	Red Flipper (2)	545-5024-02
M.	Shooter Tip (1)	545-5027-00

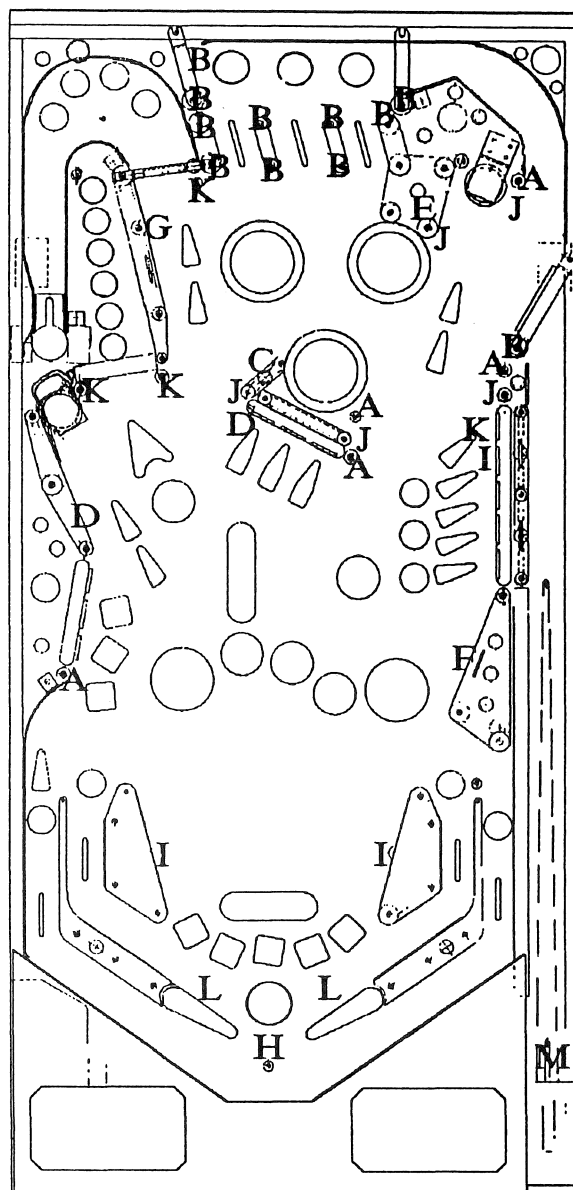

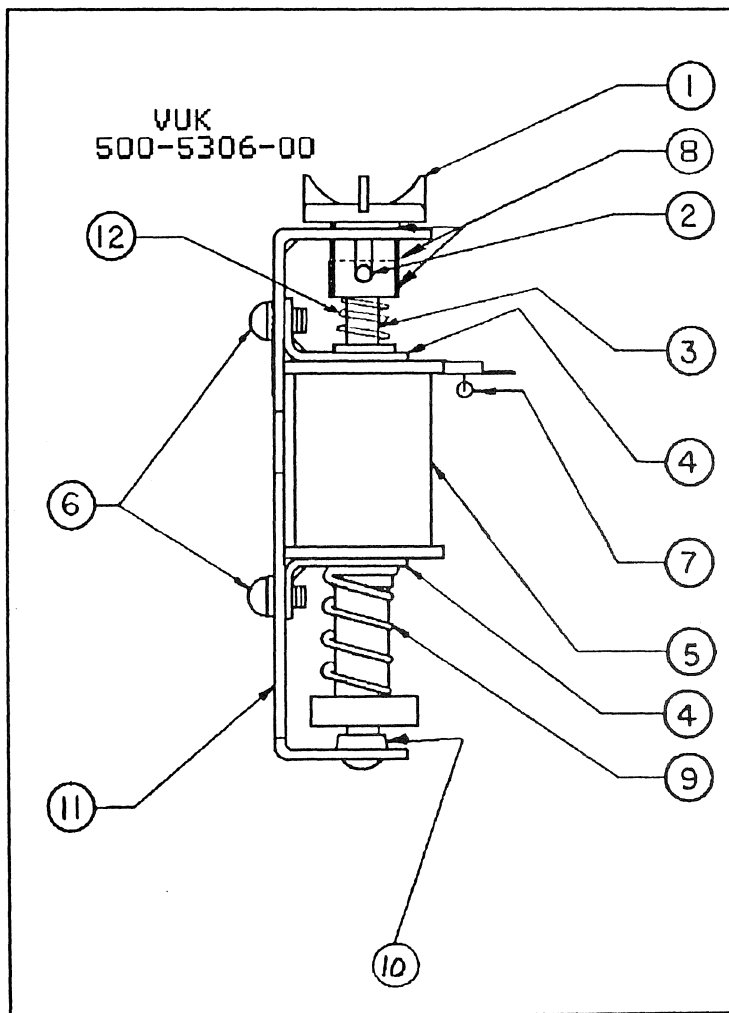
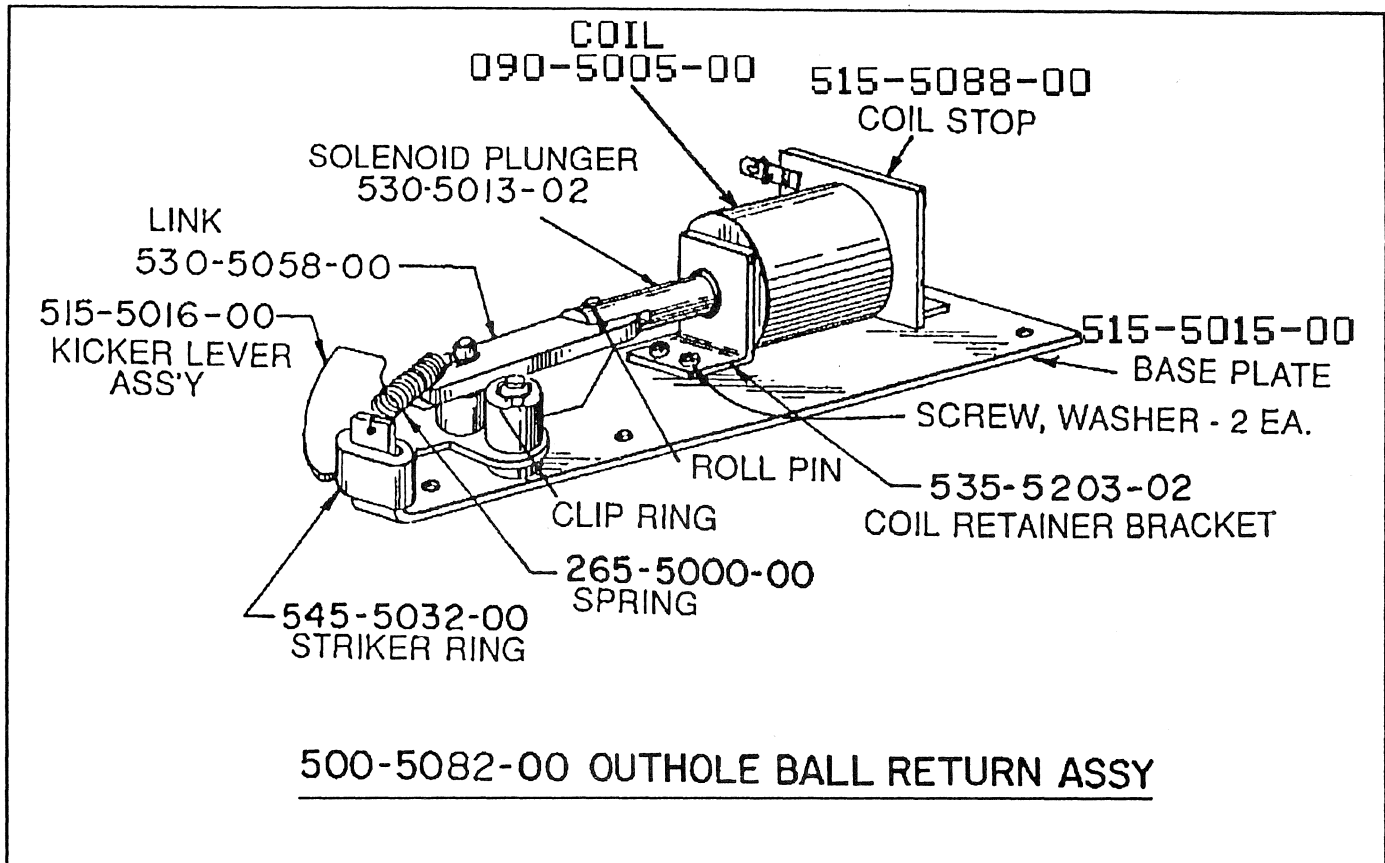

Item	Part #	Description
1	545-5227-00	Vert. Kick. Cap
2	535-5111-00	Pin ³ / ₃₂ x ⁷ / ₁₆
3	515-5352-00	Plunger Assy.
4	535-5001-01	Coil Retainer Brkt. (2)
5	090-5001-01	Coil 23-800
6	232-5300-00	#8-32X ¹ / ₄ Phil. (4)
7	112-5003-00	1N4004 Diode
8	270-5010-00	Compression Ring(3)
9	266-5009-00	Spring
10	280-5003-00	Bumper
11	535-5271-00	VUK Bracket
12	266-5025-00	Cap Spring
13*	545-5193-00	Sw. Insulator
14*	180-5063-00	Micro Switch
15*	267-5806-00	#2-56X ¹ / ₂
16*	244-5001-00	Lock Washer
17*	240-5301-00	Hex Nut

* Indicates not shown

Item	Description	Part No.
1	Target End Plate (2)	535-0152-00
2	Bank Target Frame	1-309-3
3	#8-32 X $\frac{3}{8}$ Screw (6)	31-802
4	Spring Mounting Plate	535-0153-00
5	Target (3)	545-5048-01
6	Drop Tgt.Retain.Brkt.	535-5042-01
7	Washer $\frac{13}{64}$ X $\frac{1}{2}$ (2)	3-103
8	Target Reset Spring (3)	265-5003-00
9	Coil Support Bracket	535-5203-02
10	#6-32 X $\frac{3}{8}$ Screw (4)	237-5501-00
11	23-800-Coil	090-5001-00
12	Coil Sleeve	260-0004-00

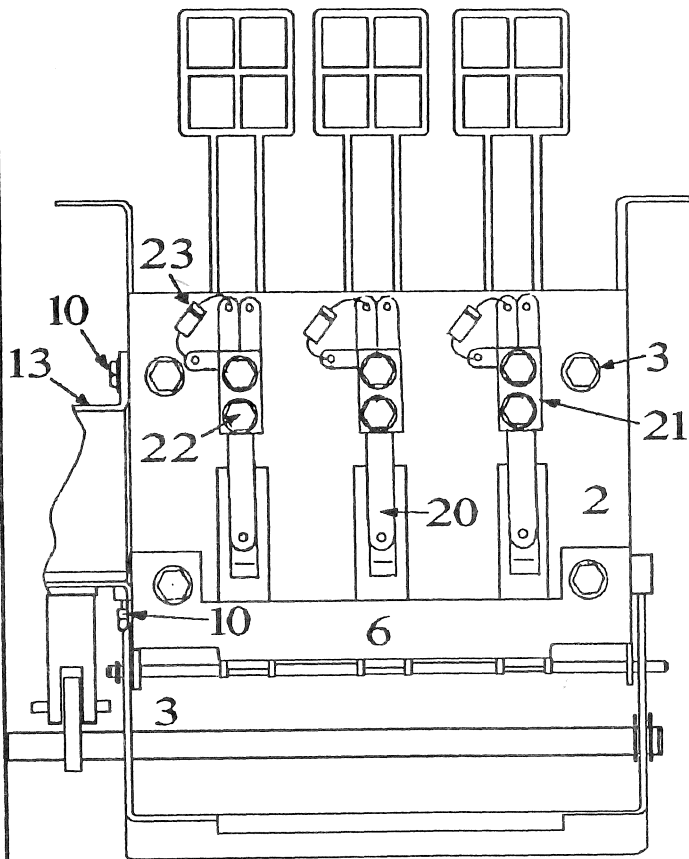
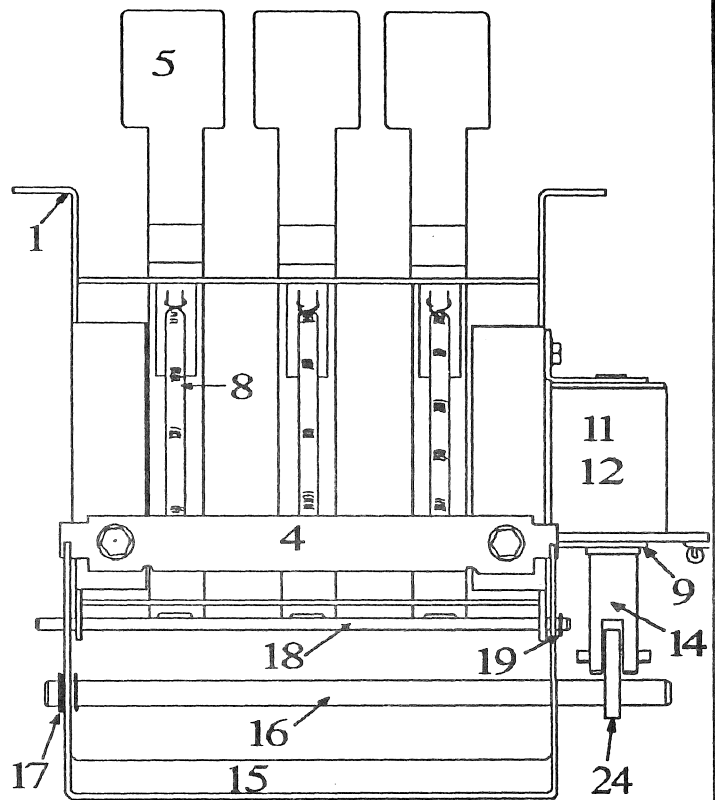

Item	Description	Part No.
13	Plunger Stop Assy.	515-5088-00
14	Plunger & Link Assy.	515-5338-00
15	Target Lift Bracket	535-0154-00
16	Target Shaft	530-0030-00
17	Retaining Ring (2)	17-100-12
18	Pivot Shaft	530-0031-00
19	Retaining Ring (2)	250-0008-00
20	Switch (3)	180-0030-00
21	SwitchPlate (3)	1-230
22	#6-32 X $\frac{1}{2}$ " (6)	237-5805-00
23	Diode 1N4001	112-5001-00
24	Link,Plunger	545-5062-00

**3 Bank Drop Target
Assembly
Both Front & Rear Views
500-5196-31**

Slingshot Assembly 500-5226-00

Item	Description	Part No.
1	Slingshot Bracket	515-5339-00
2	S.S. Arm & Tip Assy.	515-5340-00
3	Plunger & Link Assy.	515-5338-00
4	1/4 Retaining Ring (2)	270-5002-00
5	Spring	266-5020-00
6	23-800 Coil	090-5001-02
7	Coil Sleeve	260-0004-00
8	Coil Retainer	535-5203-01
9	#8-32 X 1/4" Screw (2)	232-5300-00
10	Slingshot Switch (2)	180-5054-00
11	Tension Plate (2)	535-5846-00
12	#4-40 X 1/2" Screw (4)	237-5837-00
13	Diode 1N4004 (2)	112-5004-00
14	Link, Plunger	545-5062-00

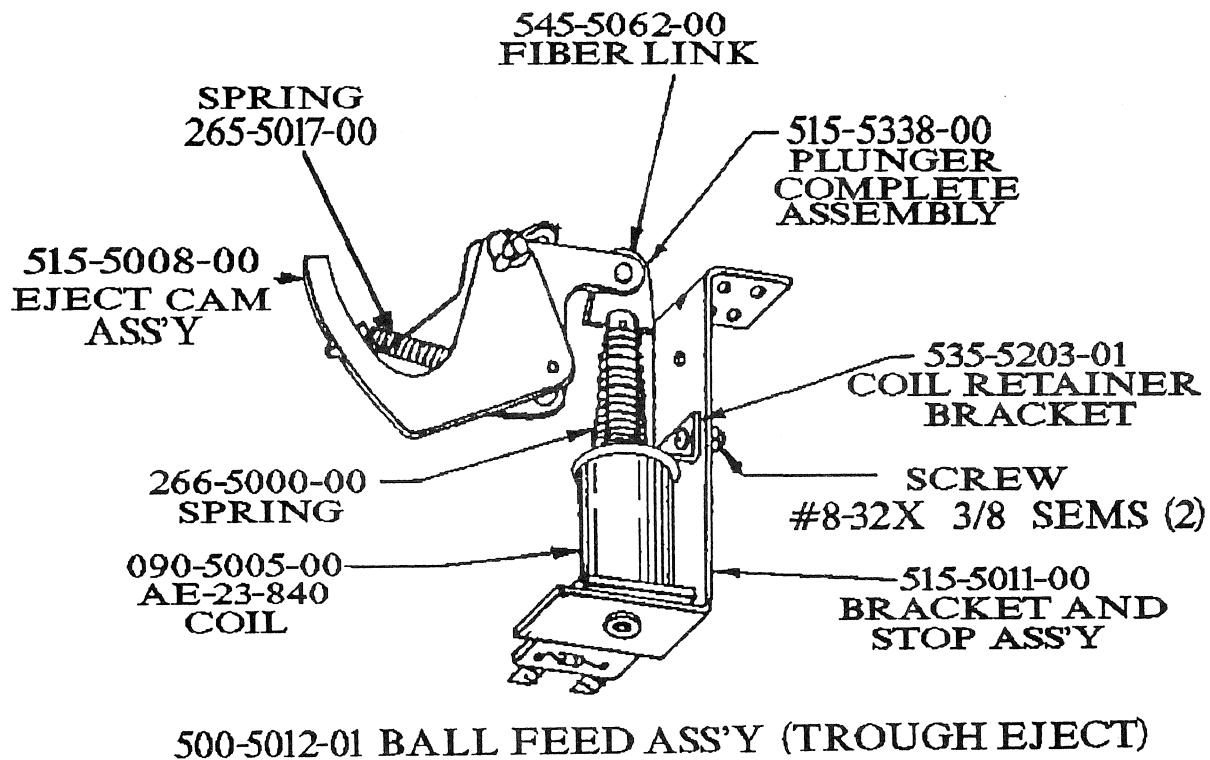
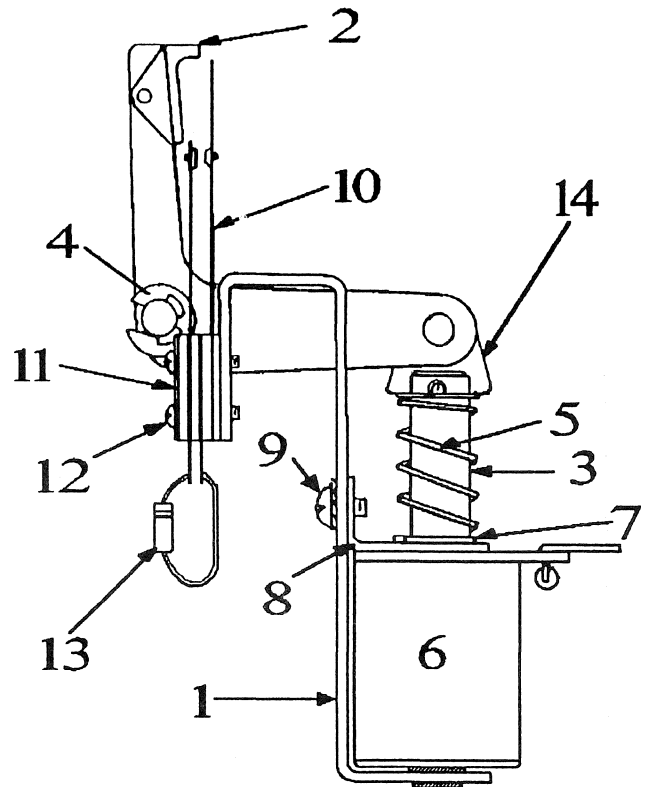

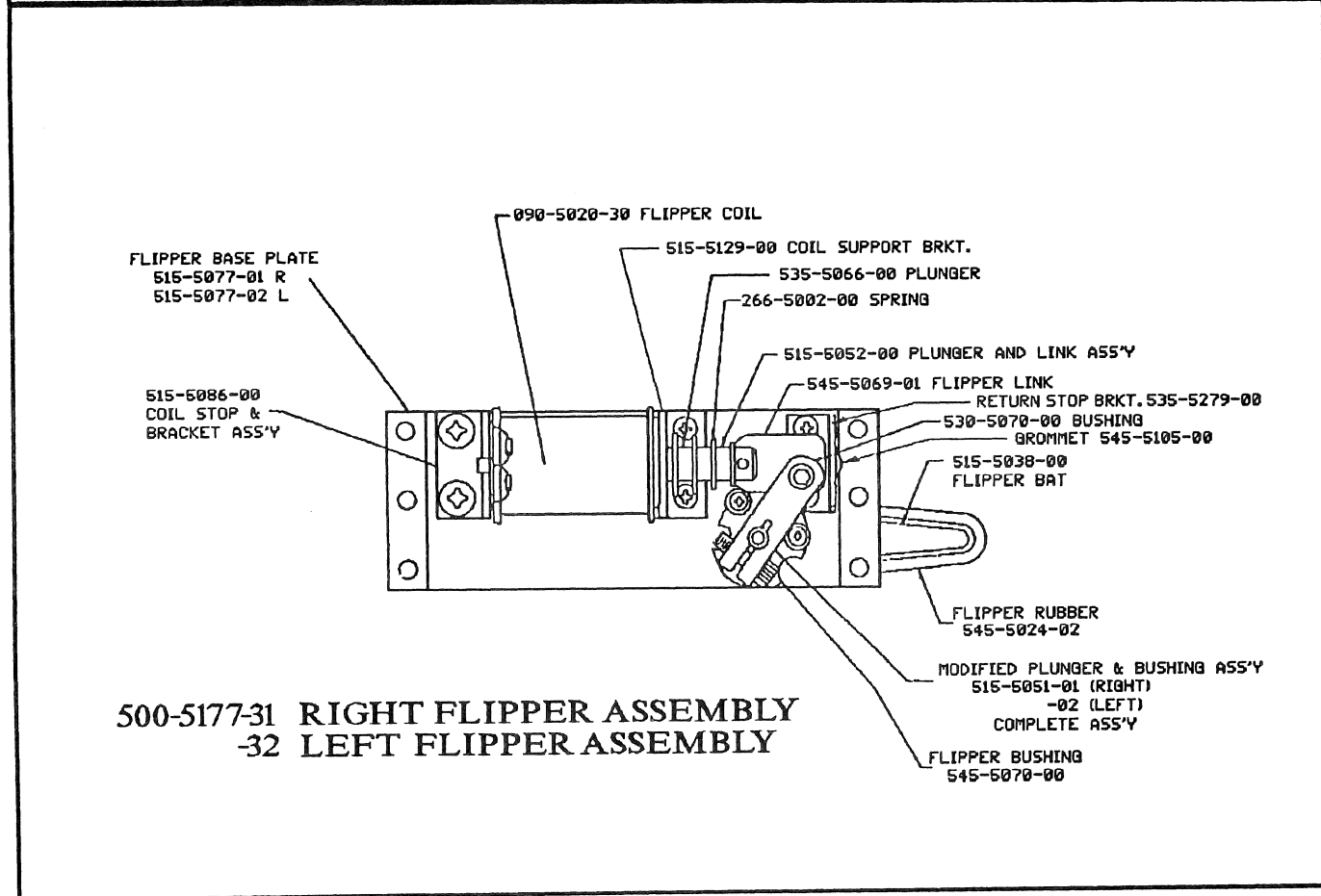
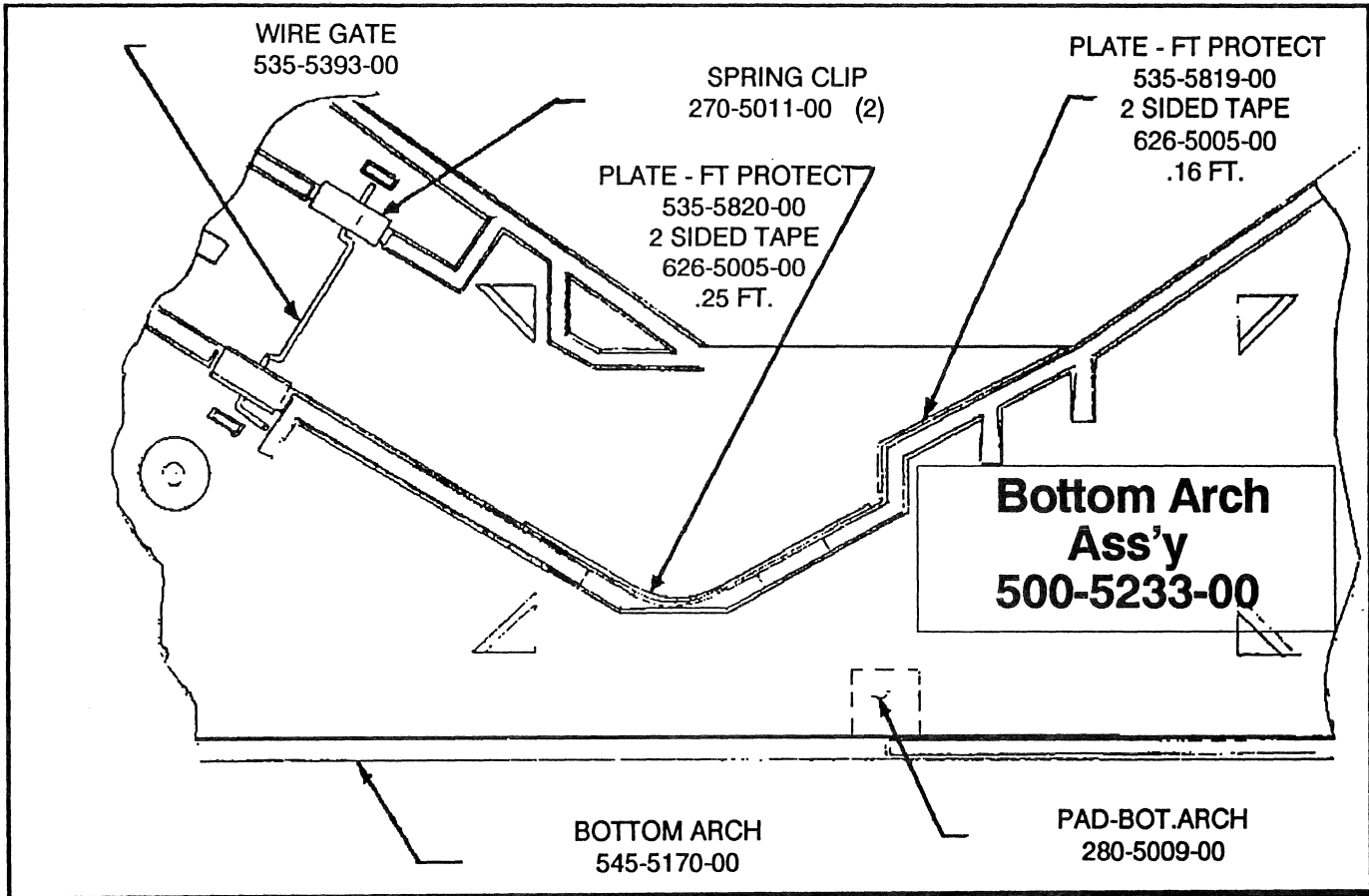

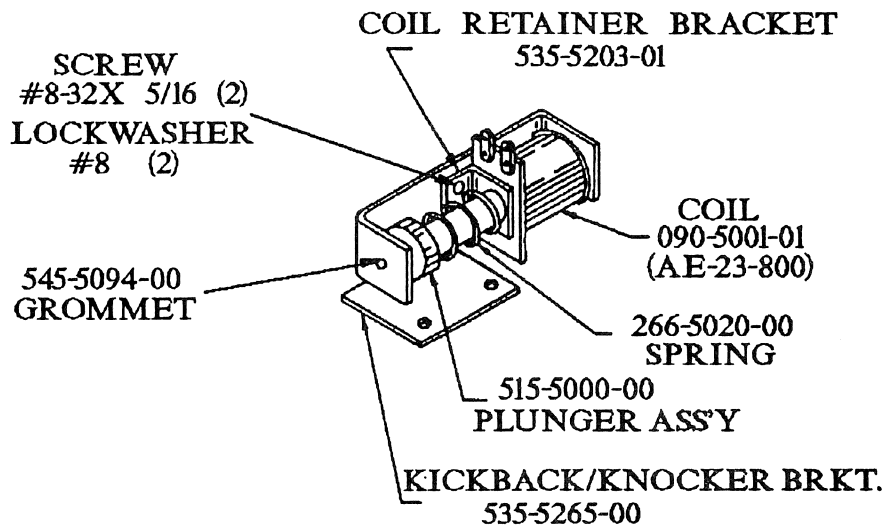

KICKBACK ASSEMBLY 500-5080-00 (COIL LUGS ON THE SIDE)
KNOCKER ASSEMBLY 500-5081-00 (PICTURED)

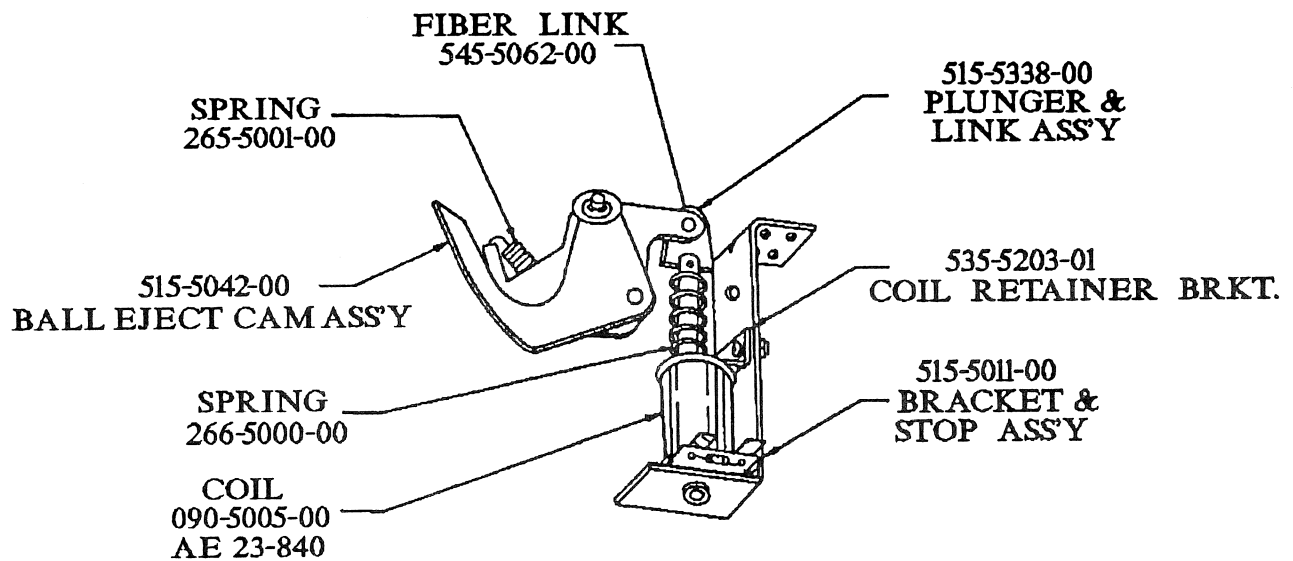

BALL EJECT ASS'Y (SAUCER)
500-5051-06

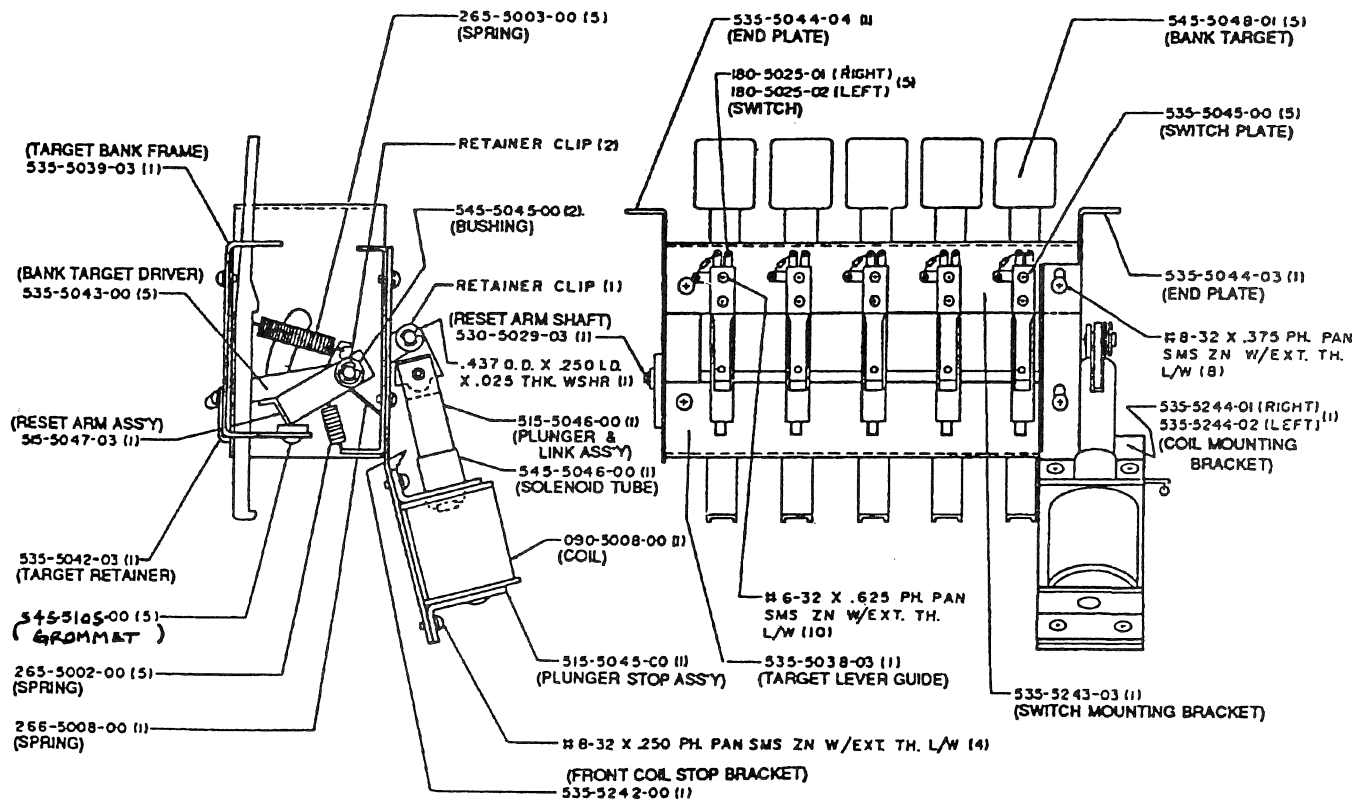

300-3055-51 (RIGHT) 5 BANK DROP TARGET
 -52 (LEFT) 5 BANK DROP TARGET

THIS CONFIGURATION FOR 115V

FOR LOWER LINE VOLTAGES
OR 230 VOLT OPERATION
SEE SAMPLES BELOW

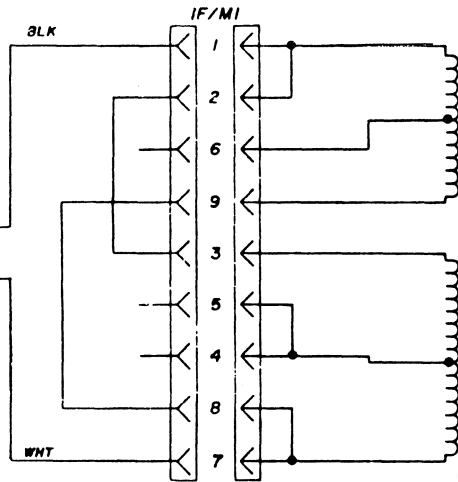
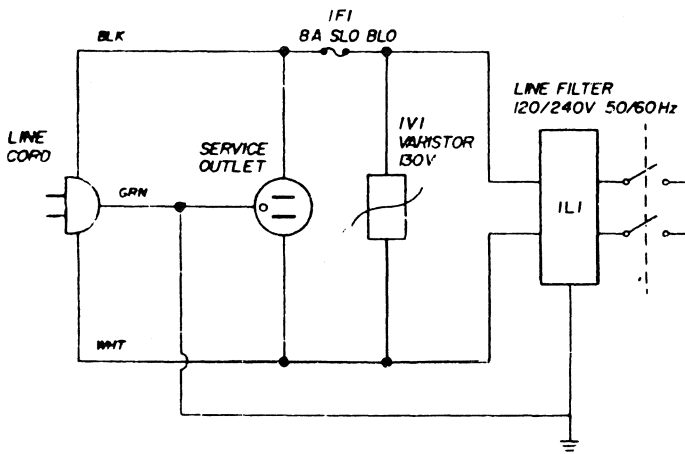

JUMPERS FOR VOLTAGE VARIATION

230/218/206 VOLTS

IF1 = 4A SLO BLO
IV1 = 275V VARISTOR

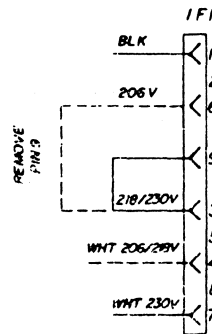

100/105 VOLTS

IF1 = 8A SLO BLO
IV1 = 130V VARISTOR

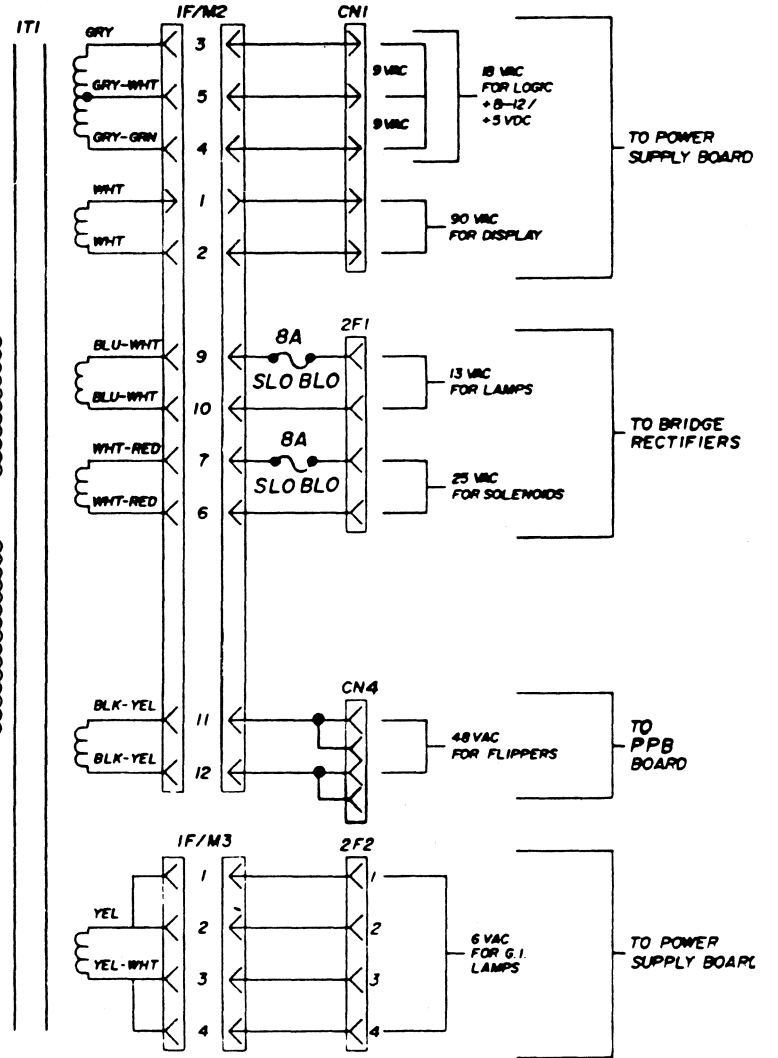
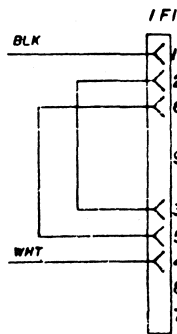

38 Cabinet Wiring Diagram

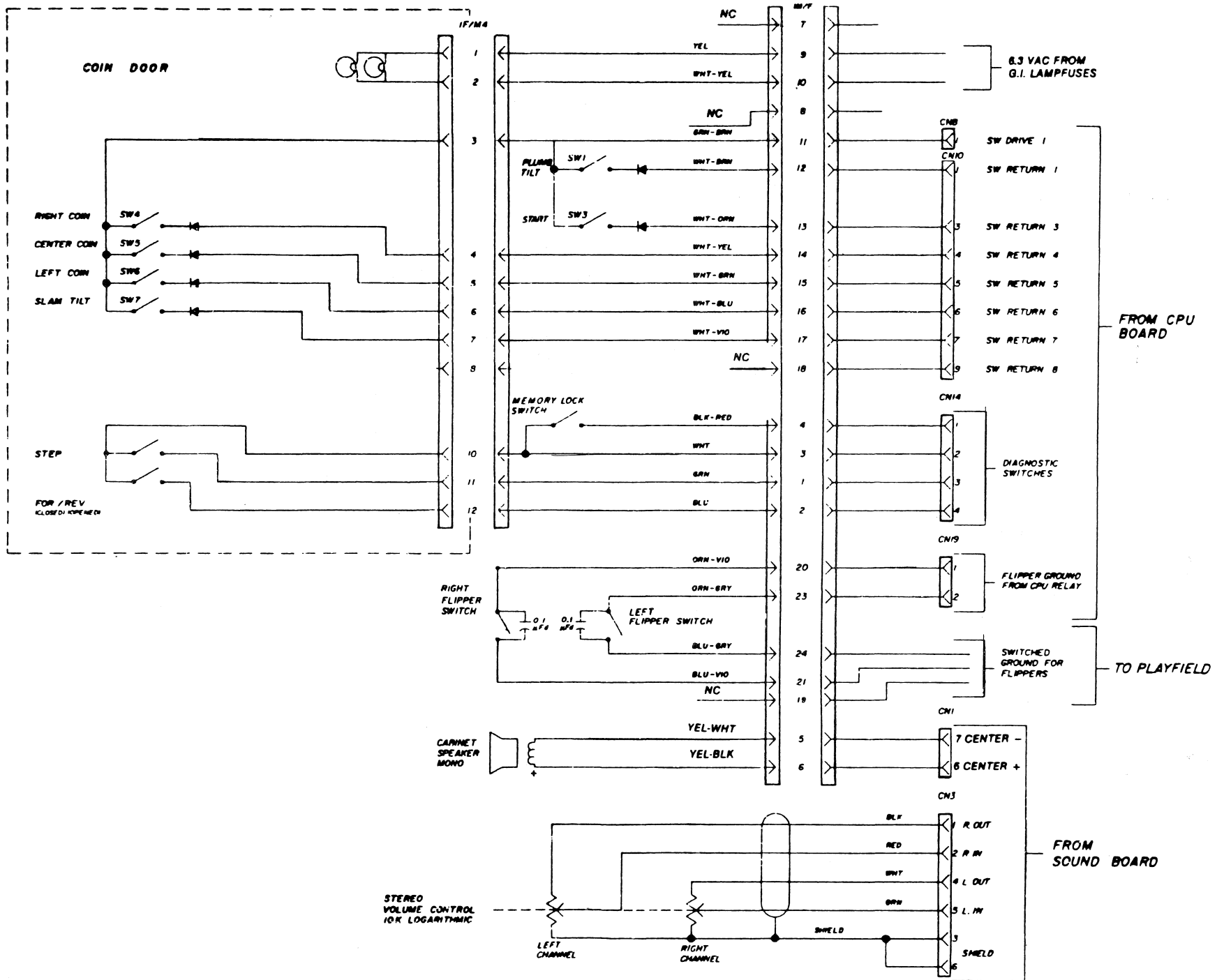

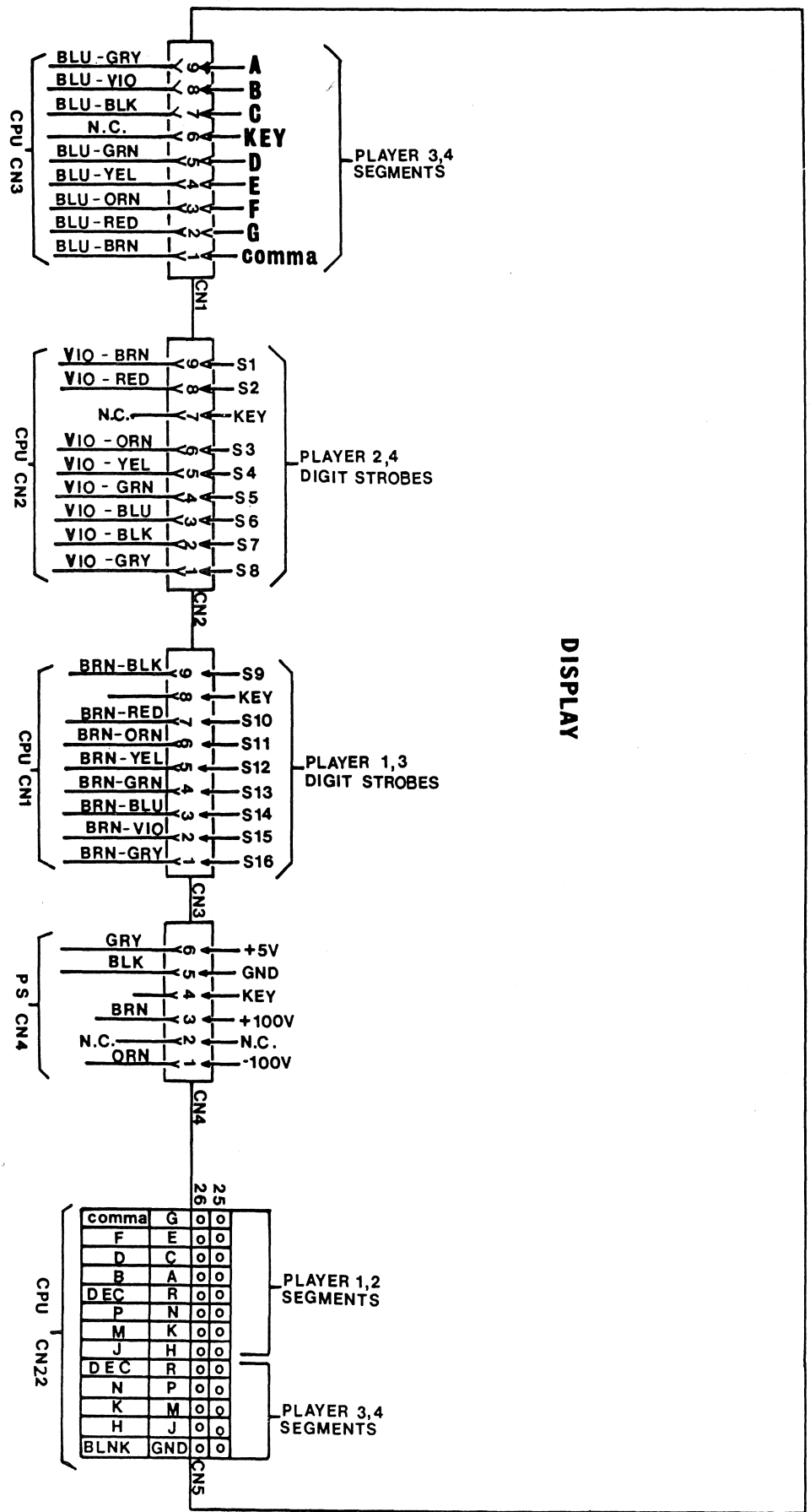

NOTES

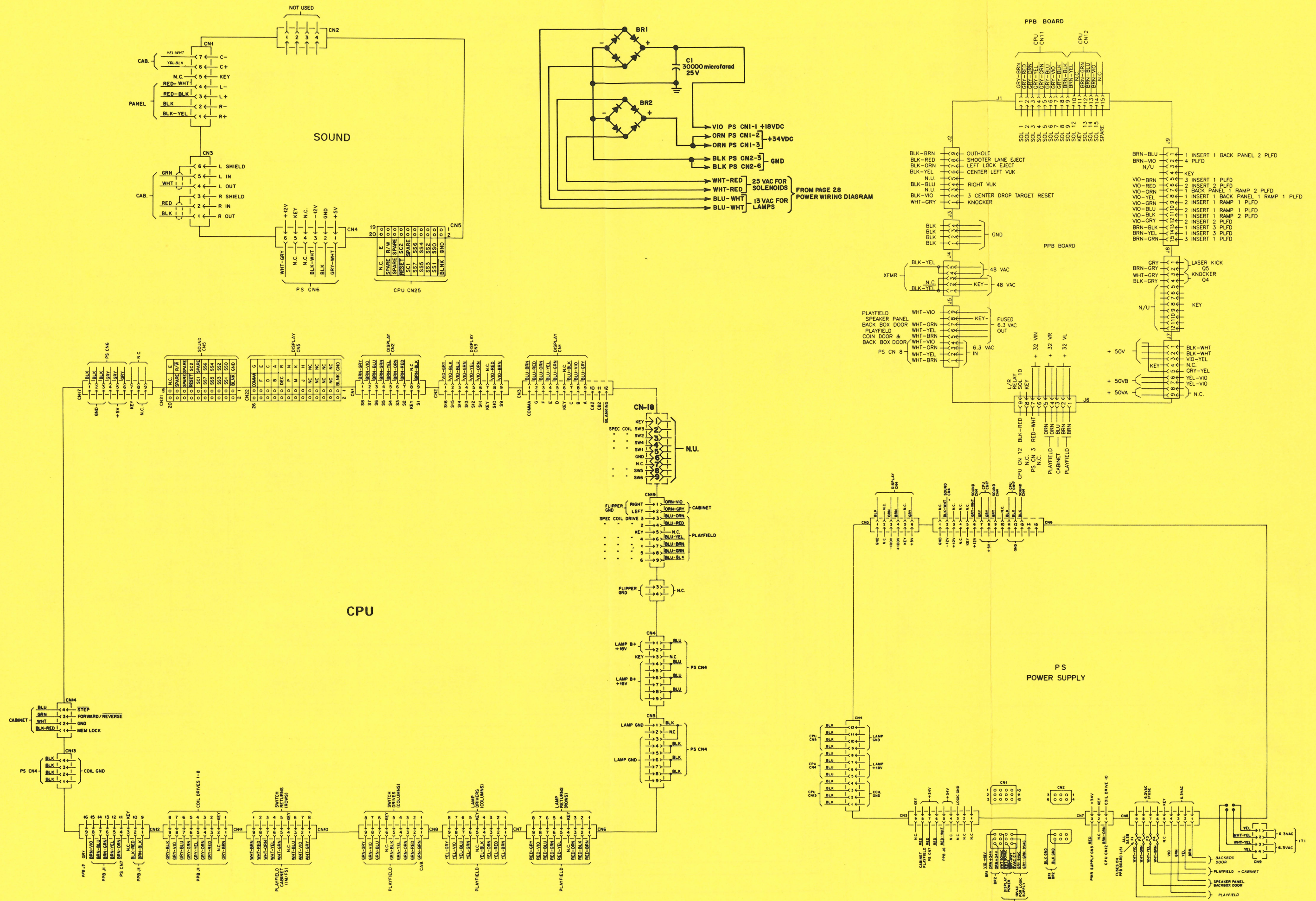

Backbox Wiring Diagram 41

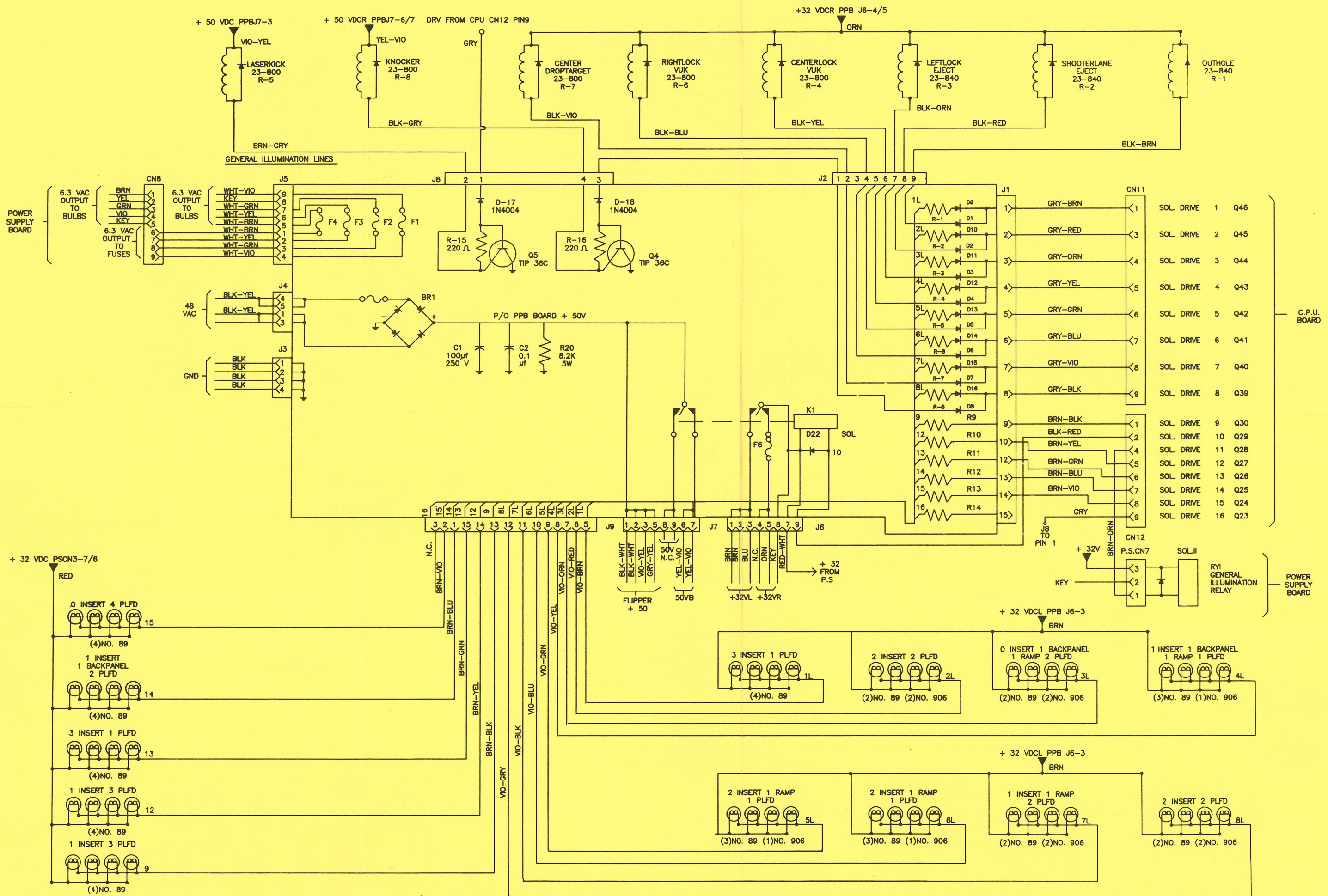

42 Playfield Coil / Flash Lamp Wiring Diagram

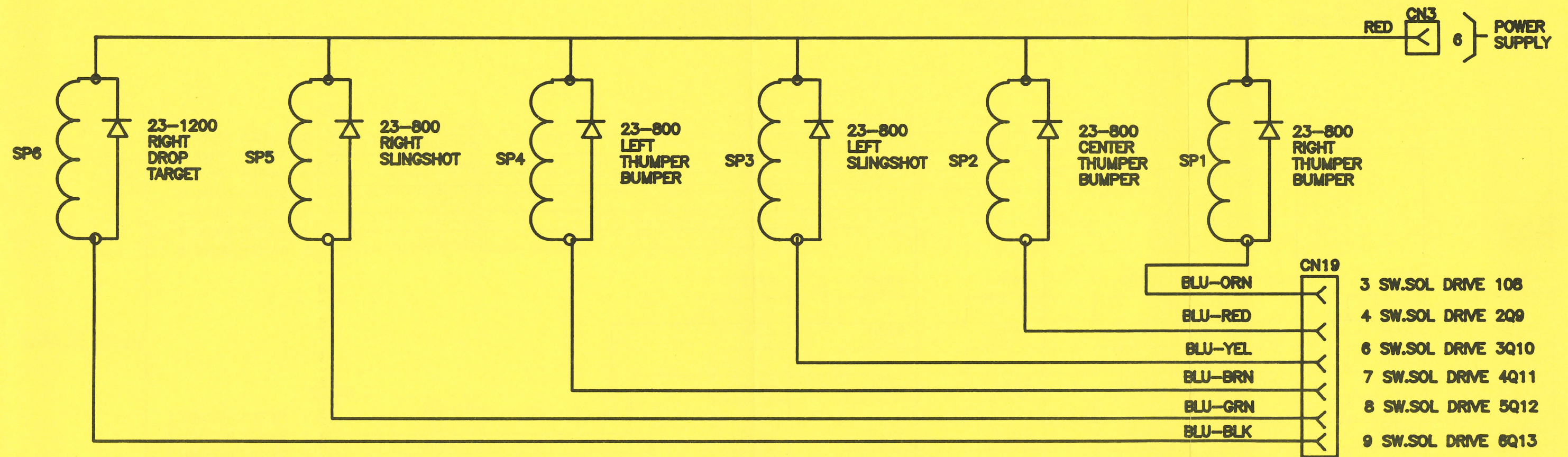

Switch Number Description

01*	Plumb Tilt	16	Right Flip.Cab. Switch	31	Not Used	46	Left Turbo Bumper
02	Not Used	17	Left Outlane	32	Not Used	47	Center Turbo Bumper
03	Credit Button	18	Left Return Lane	33	Center D.T. Left	48	Right Turbo Bumper
04*	Right Coin	19	Right Outlane	34	Center D.T. Center	49	Top Lane Right
05*	Center Coin	20	Right Return Lane	35	Center D.T. Right	50	Top Lane Center
06*	Left Coin	21	Left Slingshot Sw. (2)	36	Spinner	51	Top Lane Left
07*	Slam Tilt	22	Right Slingshot Sw. (2)	37	Right Lock	52	Thru 64 Not Used
08	Not Used	23	Not Used	38	Ramp Entrance		
09	Not Used	24	Not Used	39	Ramp Exit		
10	Out Hole	25	Chocolate	40	Not Used		
11	Trough #1(Left)	26	Double Chocolate	41	Right Bank 1 (Top)		
12	Trough #2(Center)	27	Triple Chocolate	42	Right Bank 2		
13	Trough #3(Right)	28	Left Lock	43	Right Bank 3		
14	Shooter Lane	29	Center Lock Bottom	44	Right Bank 4		
15	Left Flip. Cab. Switch	30	Center Lock Top	45	Right Bank 5 (Bot.)		

* Indicates cabinet switches.

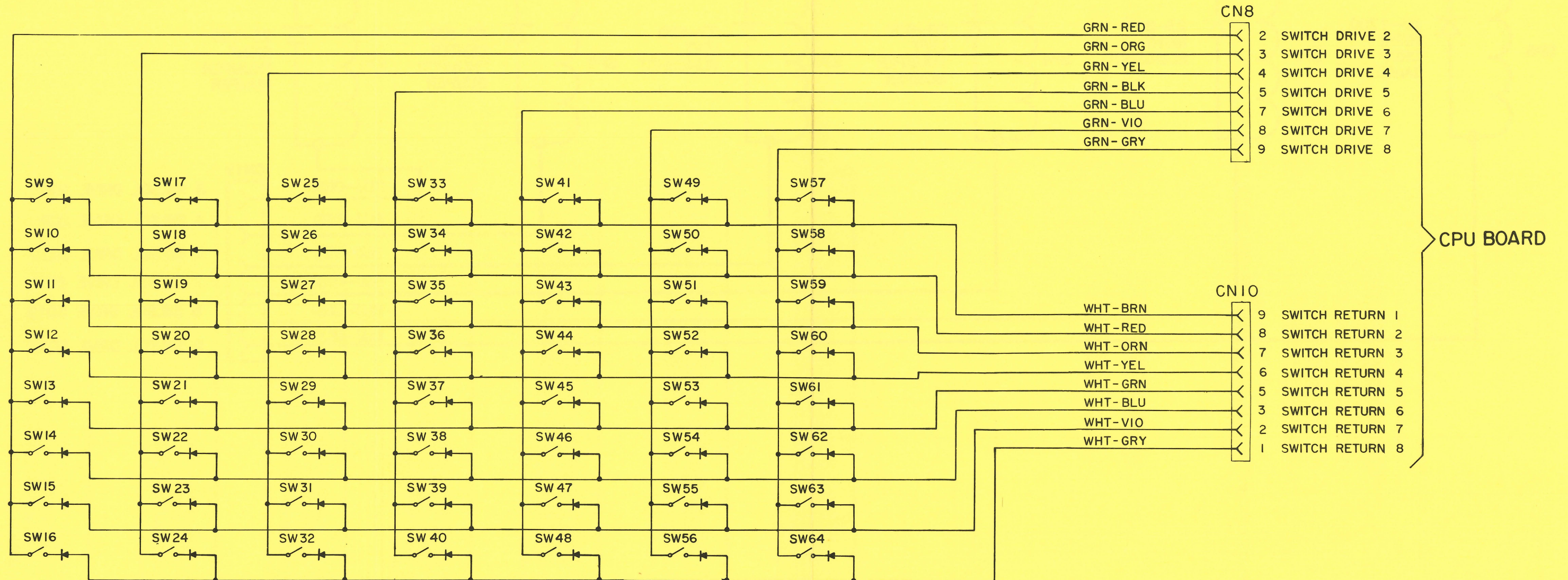

Lamp Number Description

*Indicates Speaker or Backbox Lamp

01	Left Turbo Bumper	17	MILLIONS	33	6X	49	Ramp Mystery
02	Center Turbo Bumper	18	MILLIONS	34	5X	50*	Mystery Bonus Hold
03	Right Turbo Bumper	19	MILLIONS	35	4X	51	Ramp Jackpot
04*	Mystery 5X	20	MILLIONS	36	3X	52	Clown
05	Top Lane Right	21	MILLIONS	37	2X	53	Red Tech Alert
06	Top Lane Center	22	MILLIONS	38	Bonus Held	54	Green Cleaning
07	Top Lane Left	23	MILLIONS	39	Marge Hair	55	Jackpot
08	Shoot Again	24	MILLIONS	40*	Mystery Scores 500K	56	Bart Right Bank
09	Chocolate	25	Arrow Bonus Hold	41	Outlane Left	57	Right Bank 1 Top
10	Double Chocolate	26	Left Lock	42	Return Right	58	Right Bank 2
11	Triple Chocolate	27	Arrow Special	43	Return Left	59	Right Bank 3
12*	Mystery Double Scores	28	Center Lock	44	Outlane Right	60	Right Bank 4
13*	Mystery Extra Ball	29	Arrow Extra Ball	45*	Jackpot 1M	61	Right Bank 5 Bottom
14	Center Bank Left	30	Lock Right	46*	Jackpot 2M	62	Right Bank Special
15	Center Bank Center	31*	Mystery Catch Up	47*	Jackpot 3M	63	Right Bank Extra Ball
16	Center Bank Right	32	Laser Kick	48*	Jackpot 4M	64	Right Bank Bonus Hold

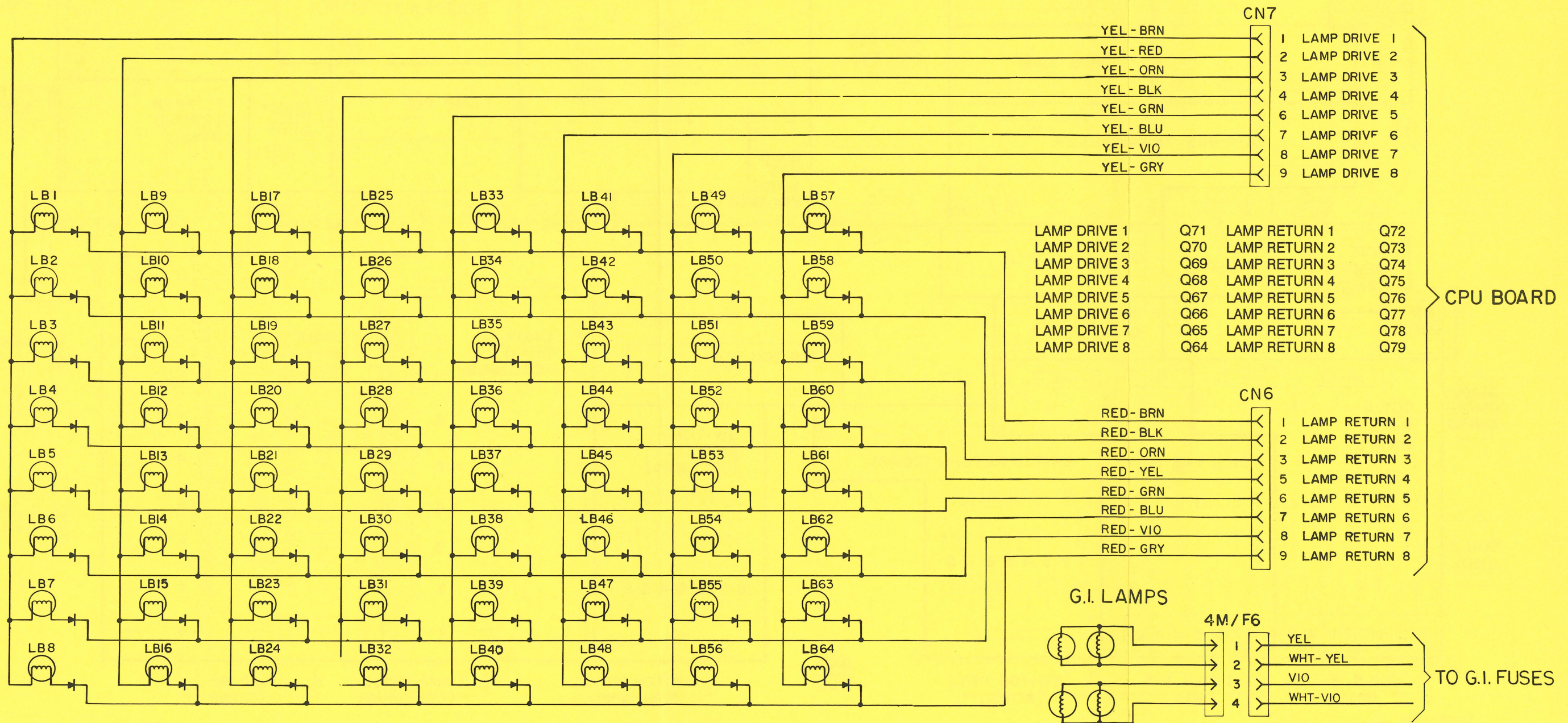

520-5003-03
MADE IN USA

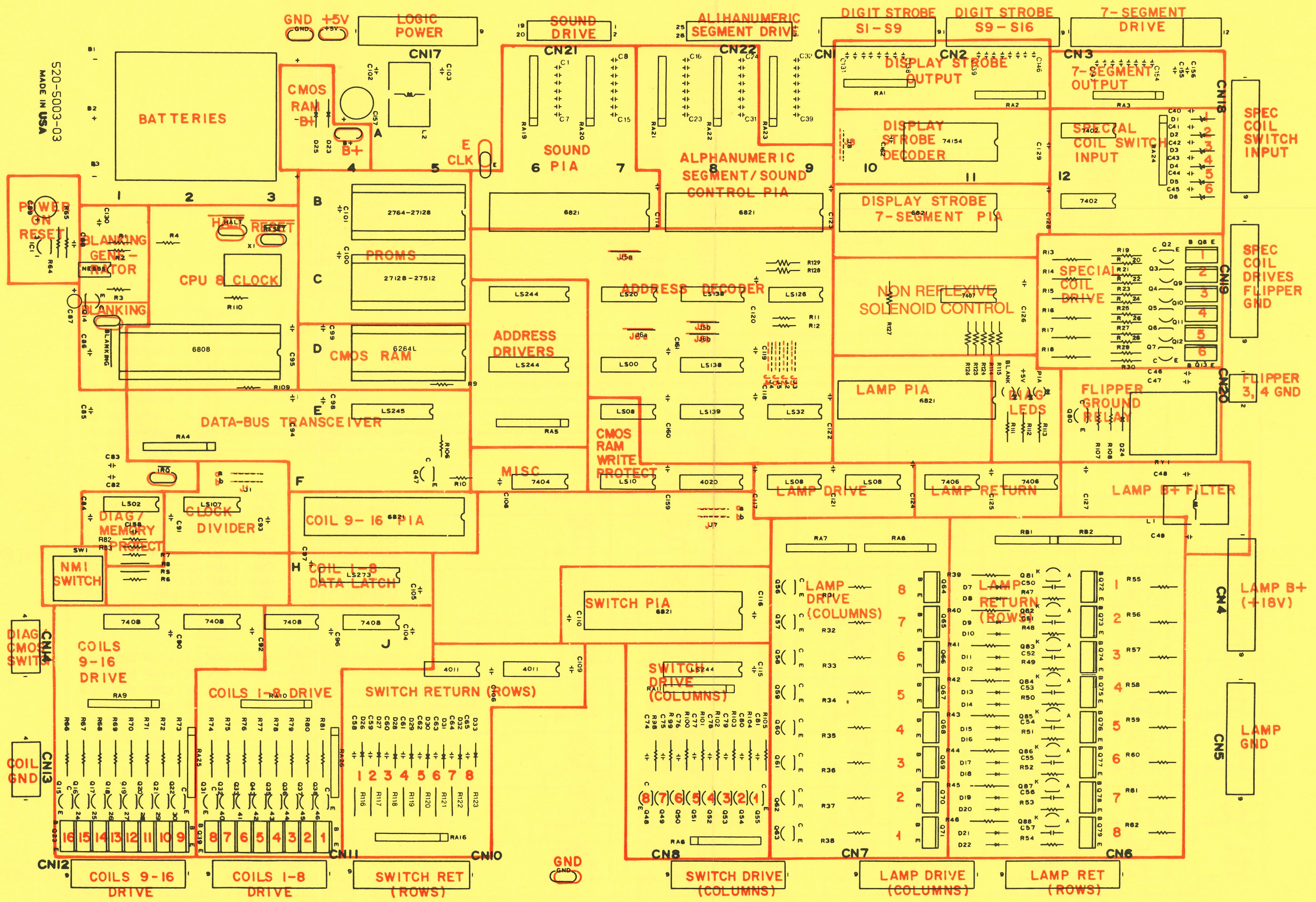

520-5003-03 REV.-A
DE-0262-3A

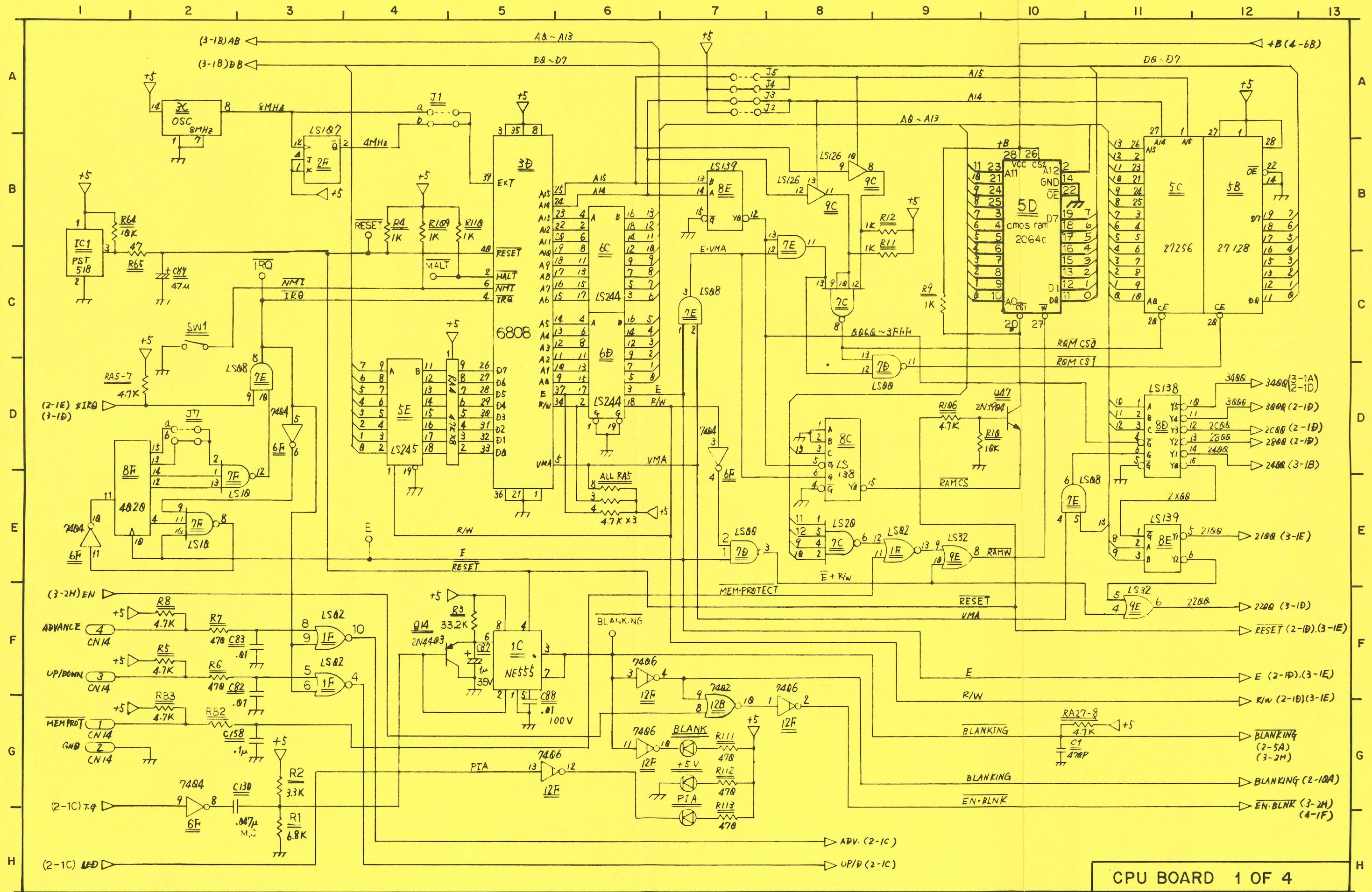

CPU BOARD 1 OF 4

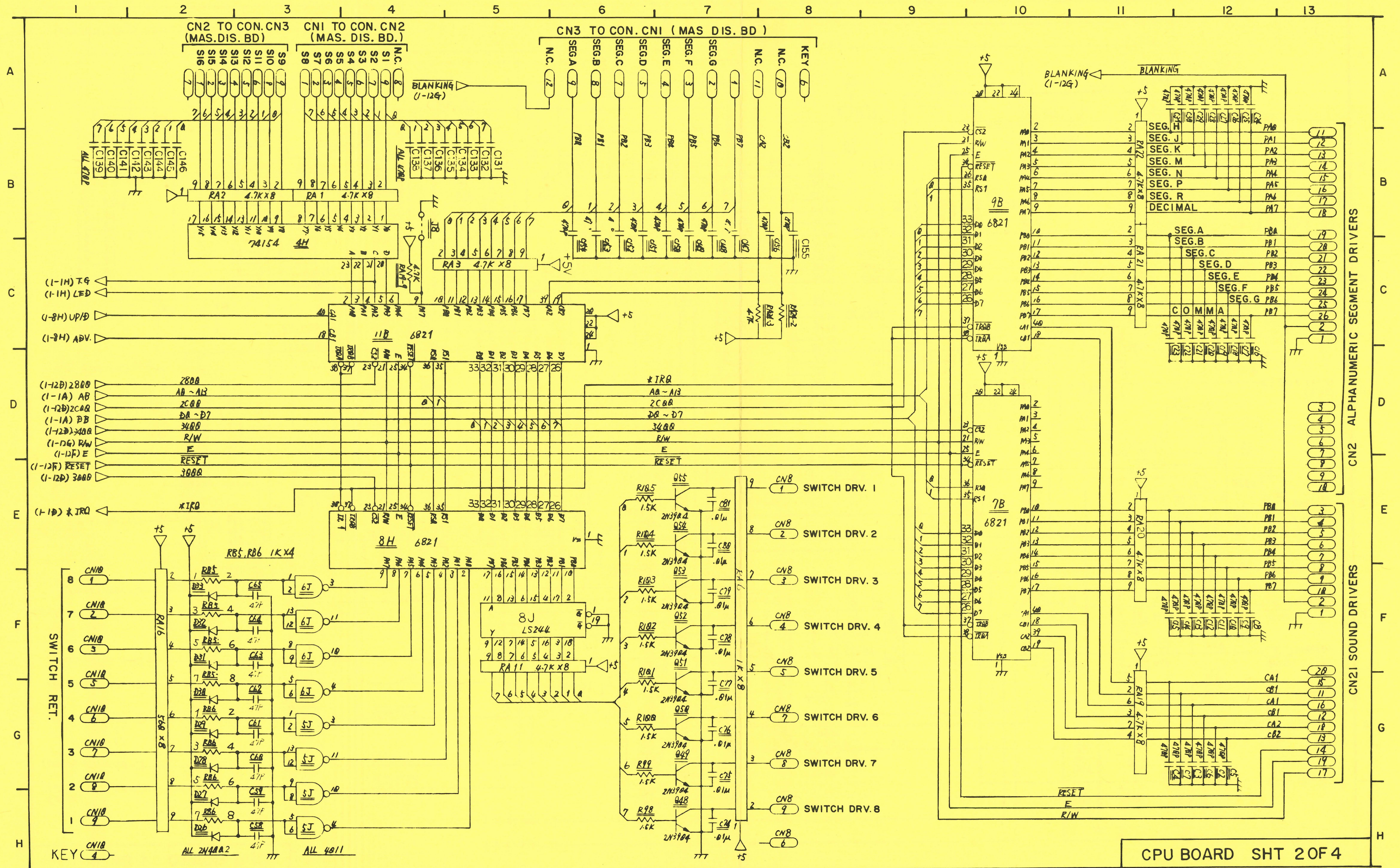

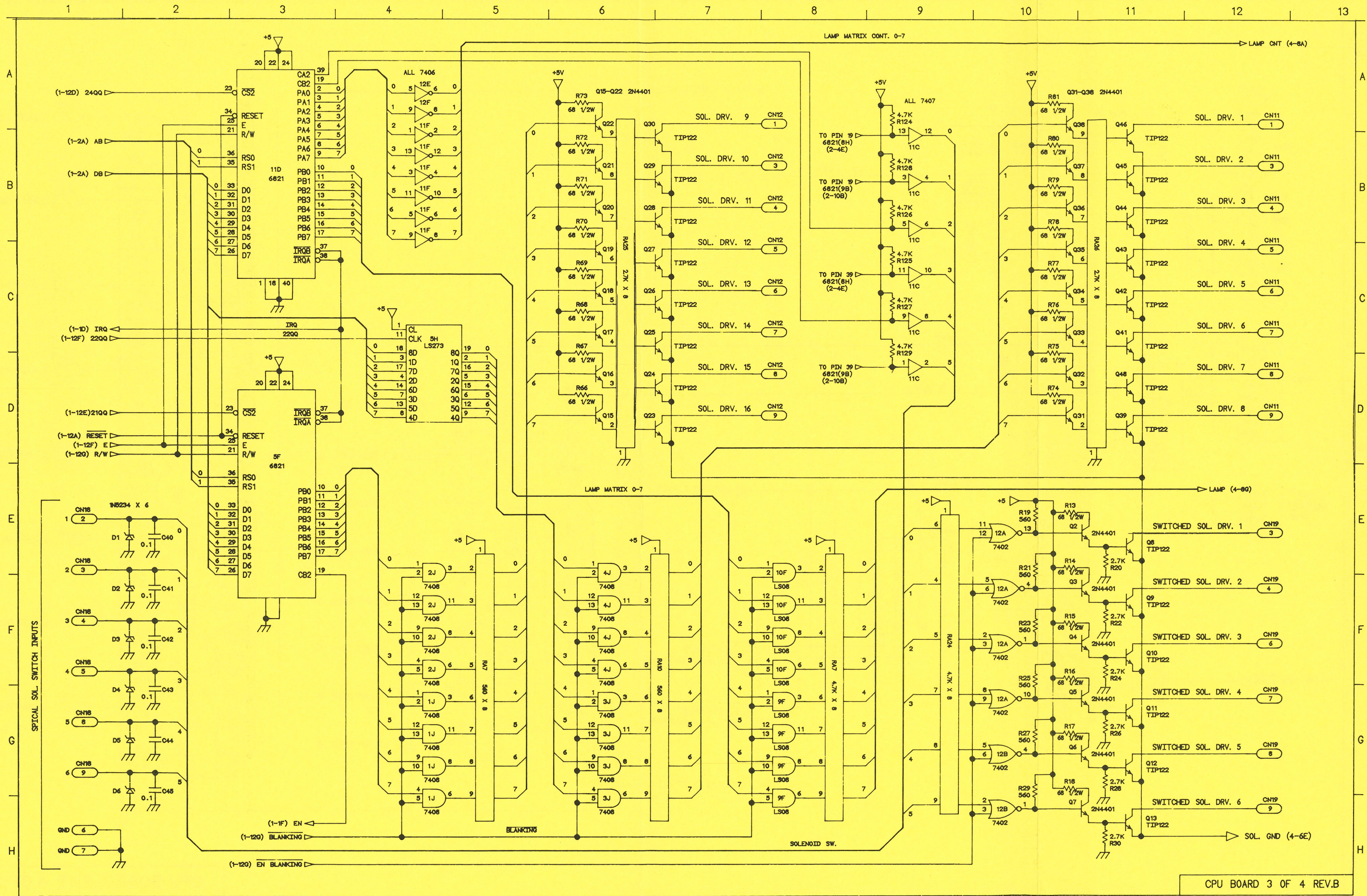

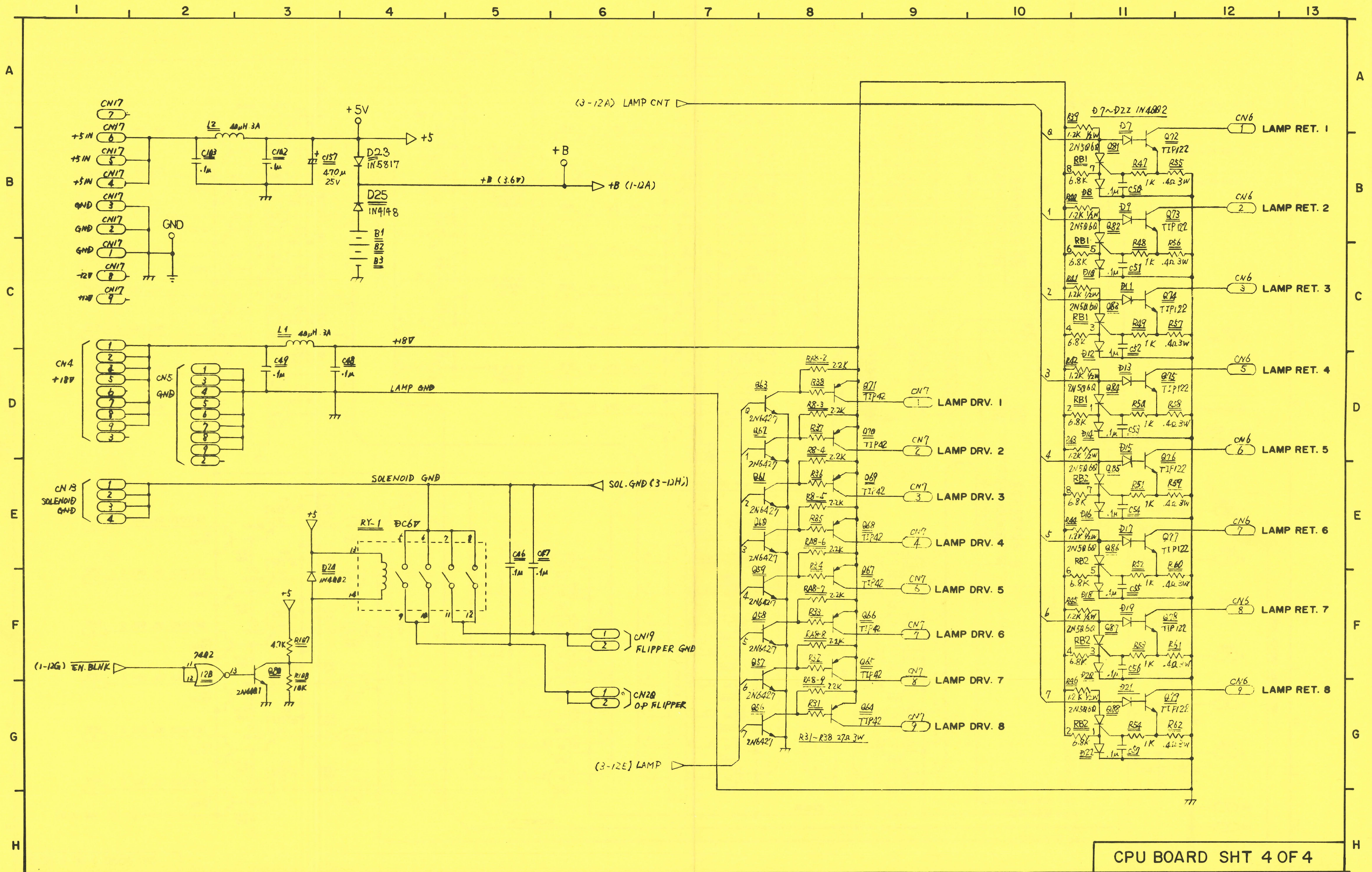

CPU BOARD SHT 4 OF 4

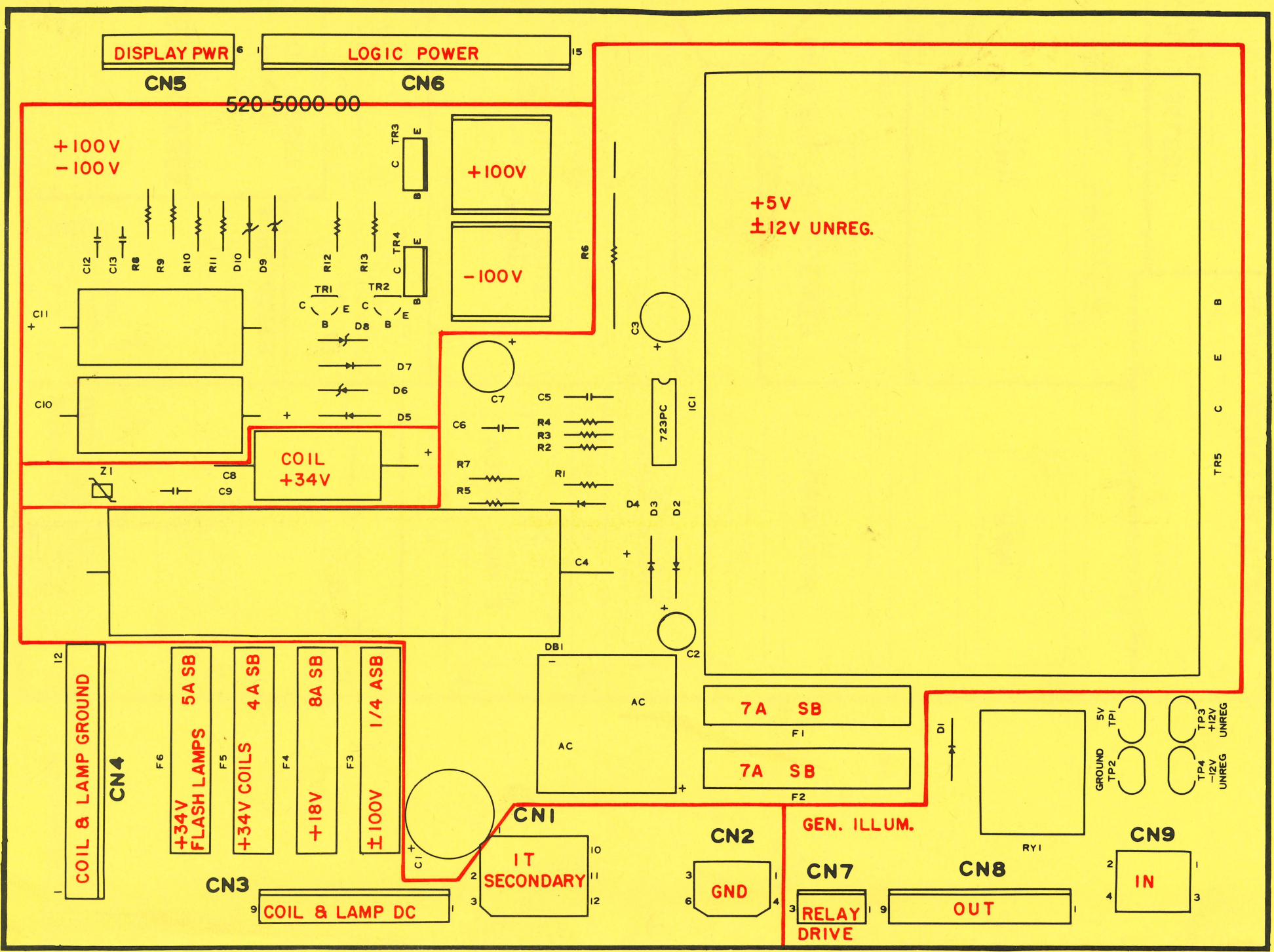
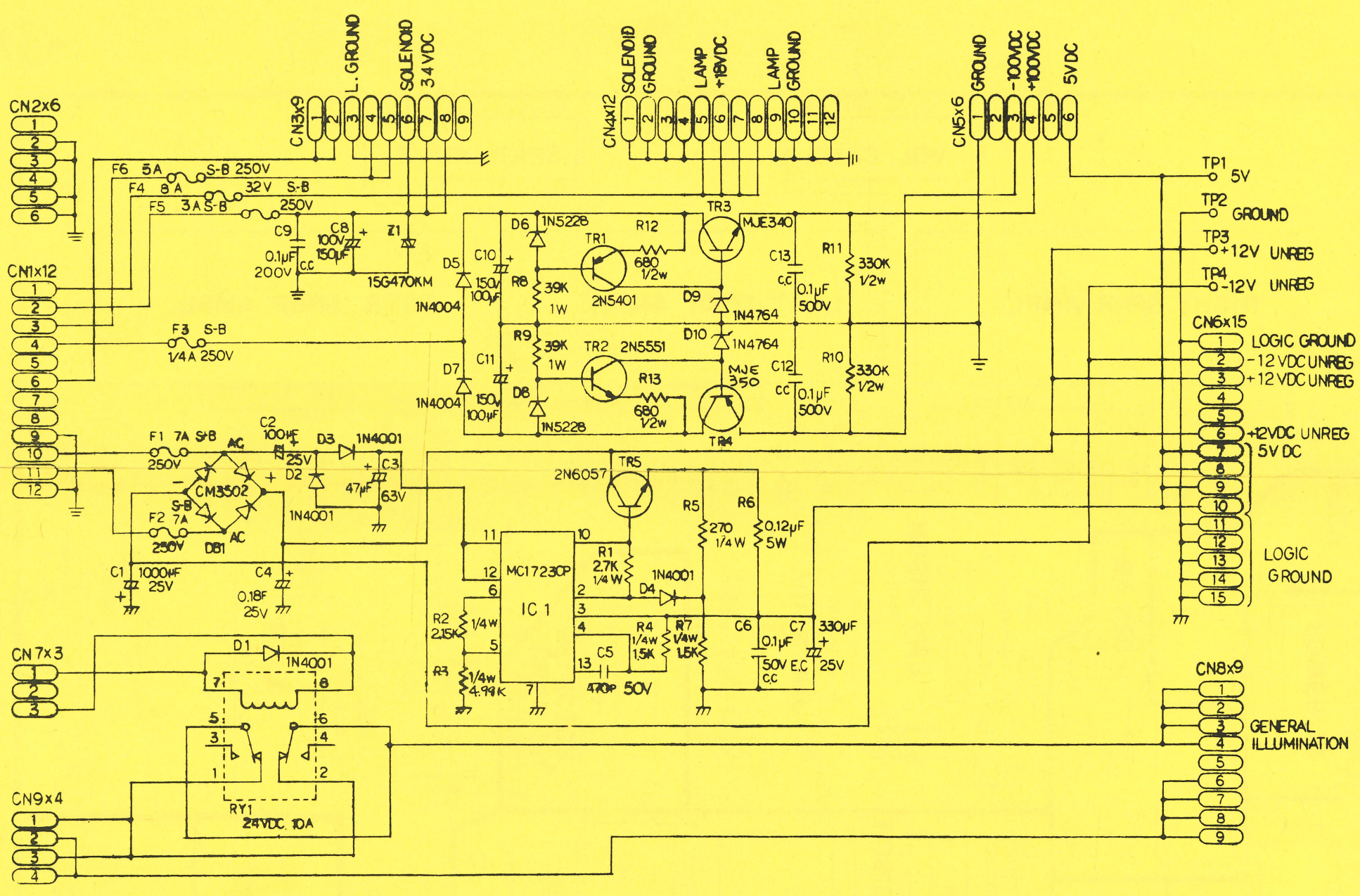

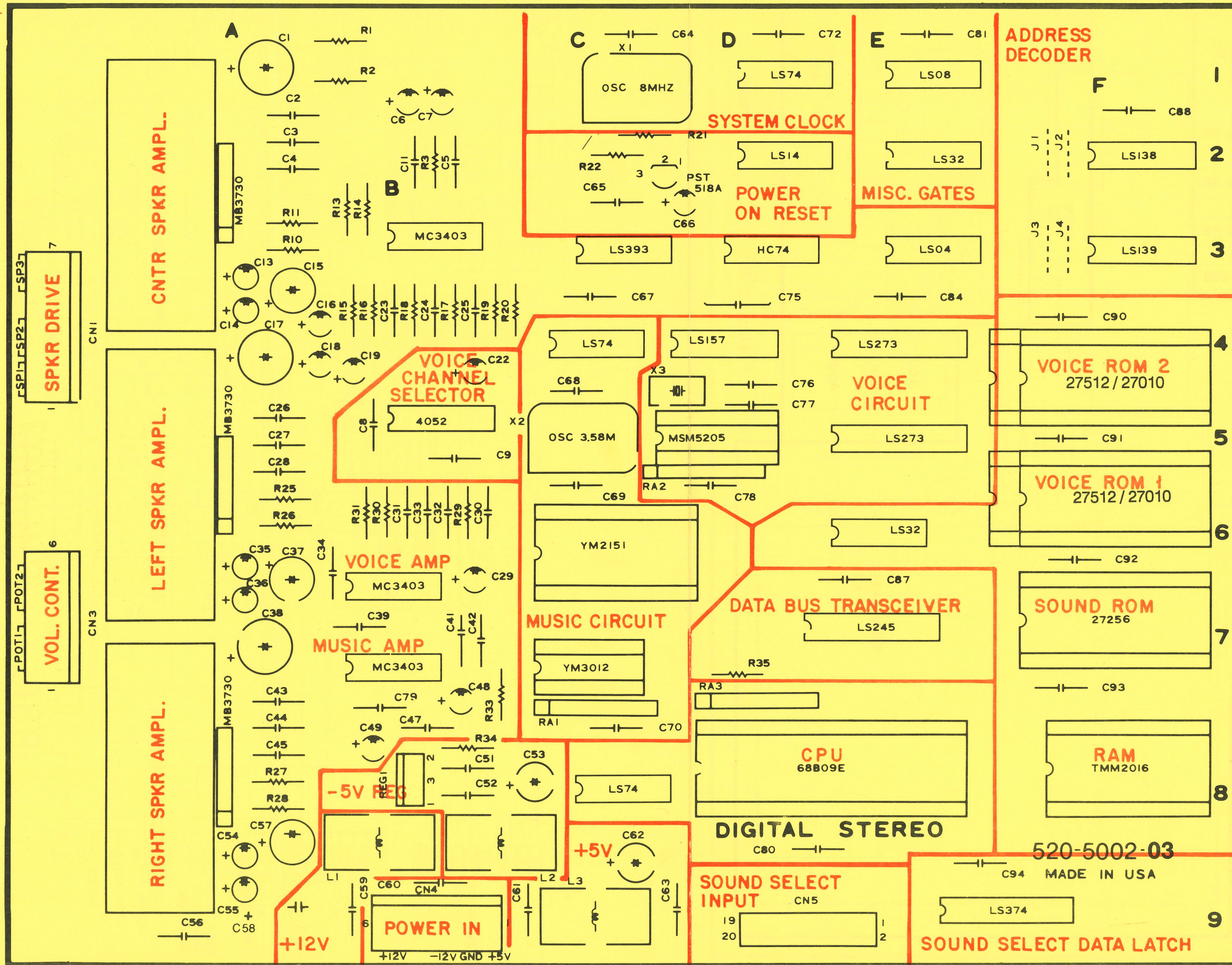

520-5002-03

MADE IN USA

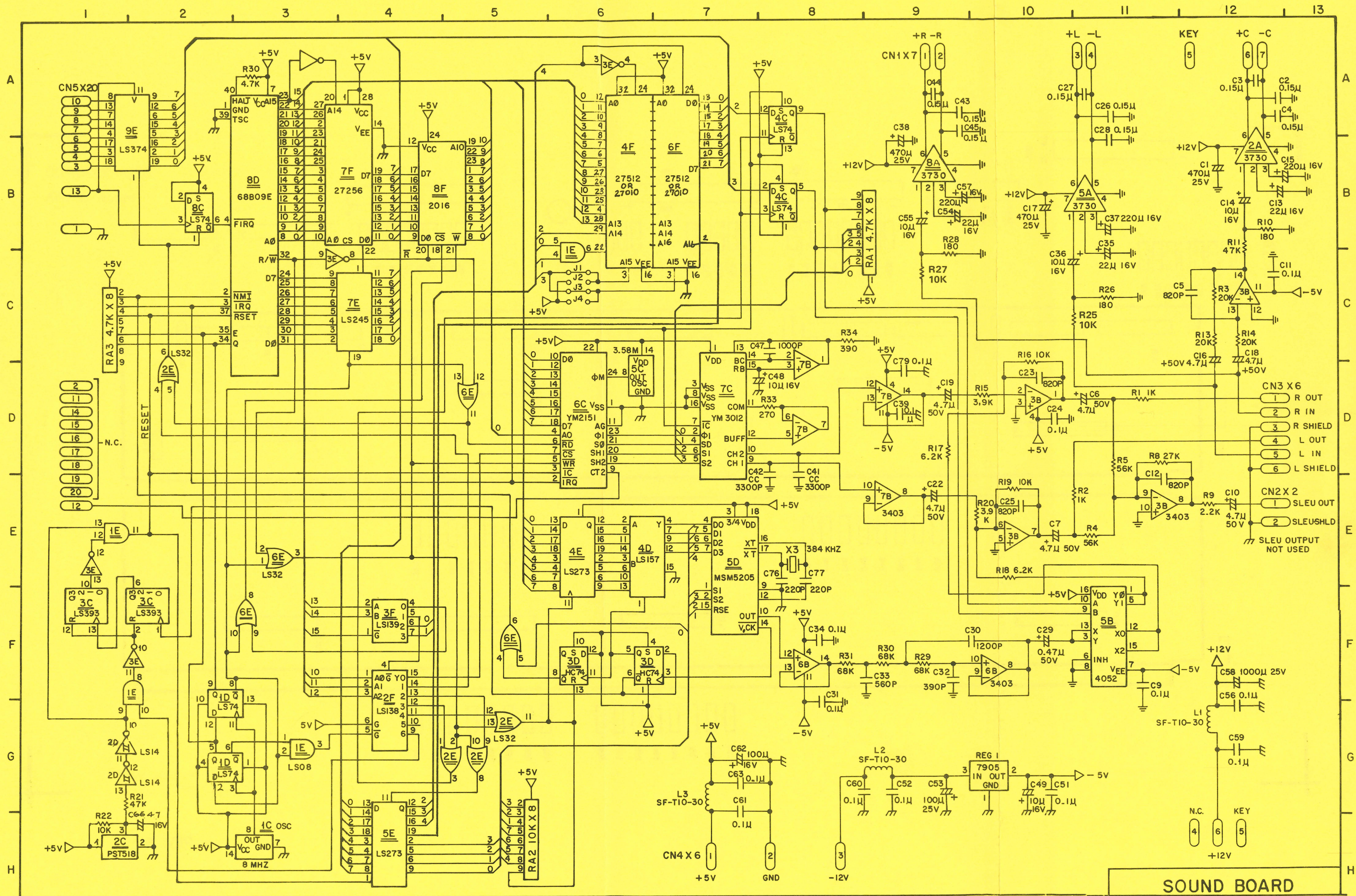

SOUND BOARD

520-5030-00
made in USA

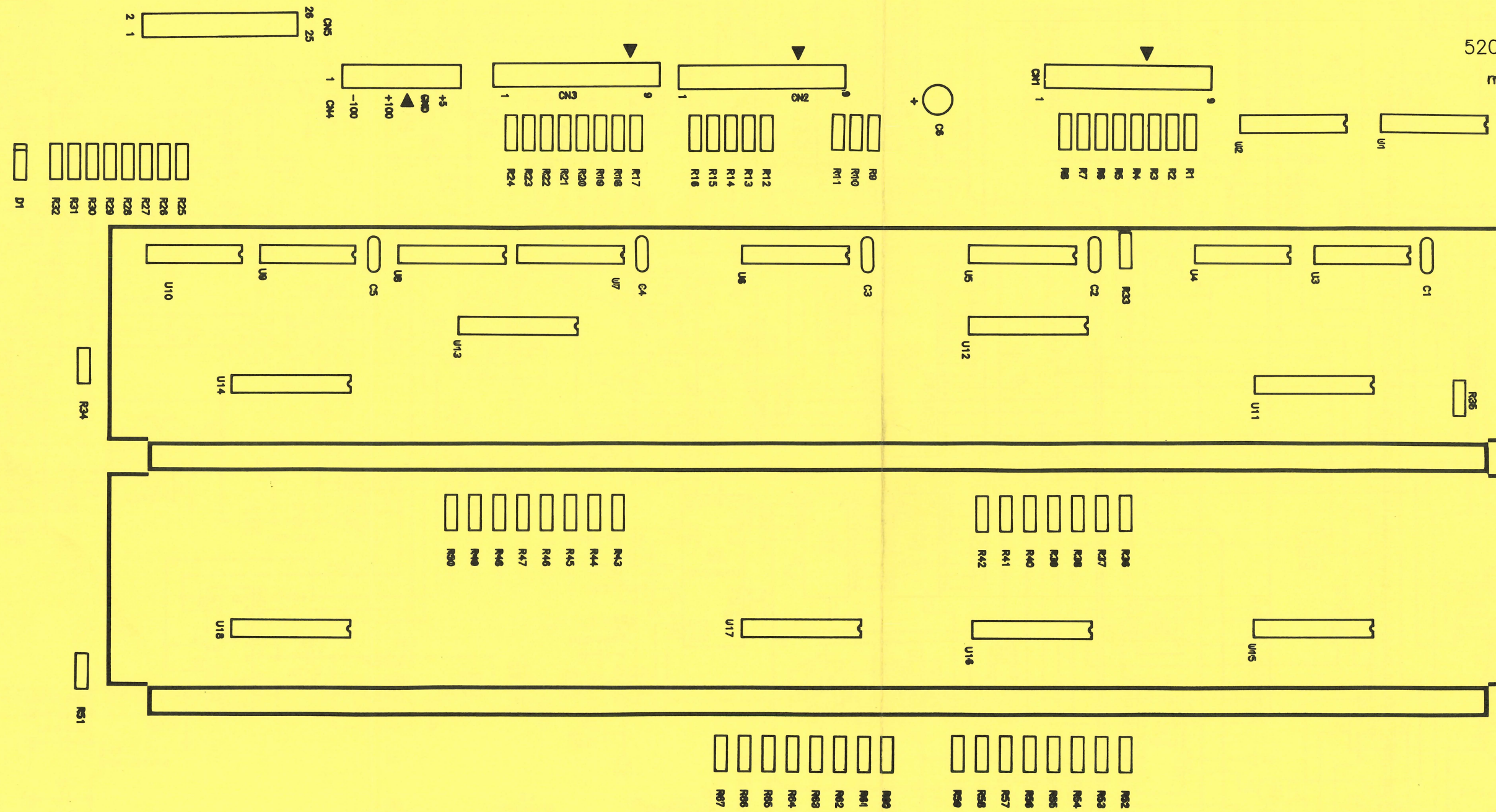

REV B

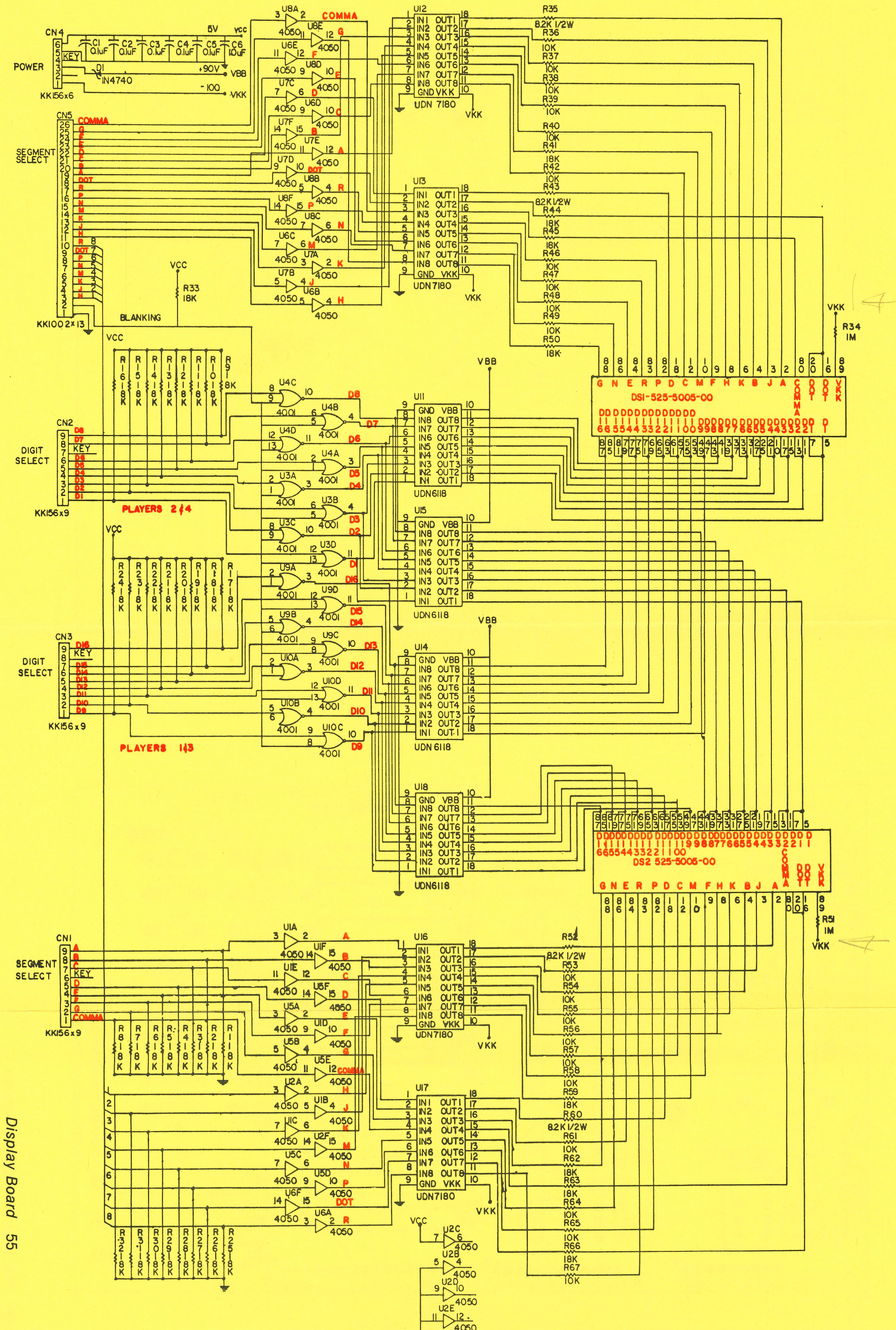

Display Board 55

DS1-525-5005-00
DDDDDDDDDDDDDDDD
DDDDDDDDDDDDDDDD
8887777666555444333222111000
751975195317539731973175197531

DS2 525-5005-00
DDDDDDDDDDDDDDDD
DDDDDDDDDDDDDDDD
8887777666555444333222111000
751975195317539731973175197531

R34
IM
VKK

R51
IM
VKK

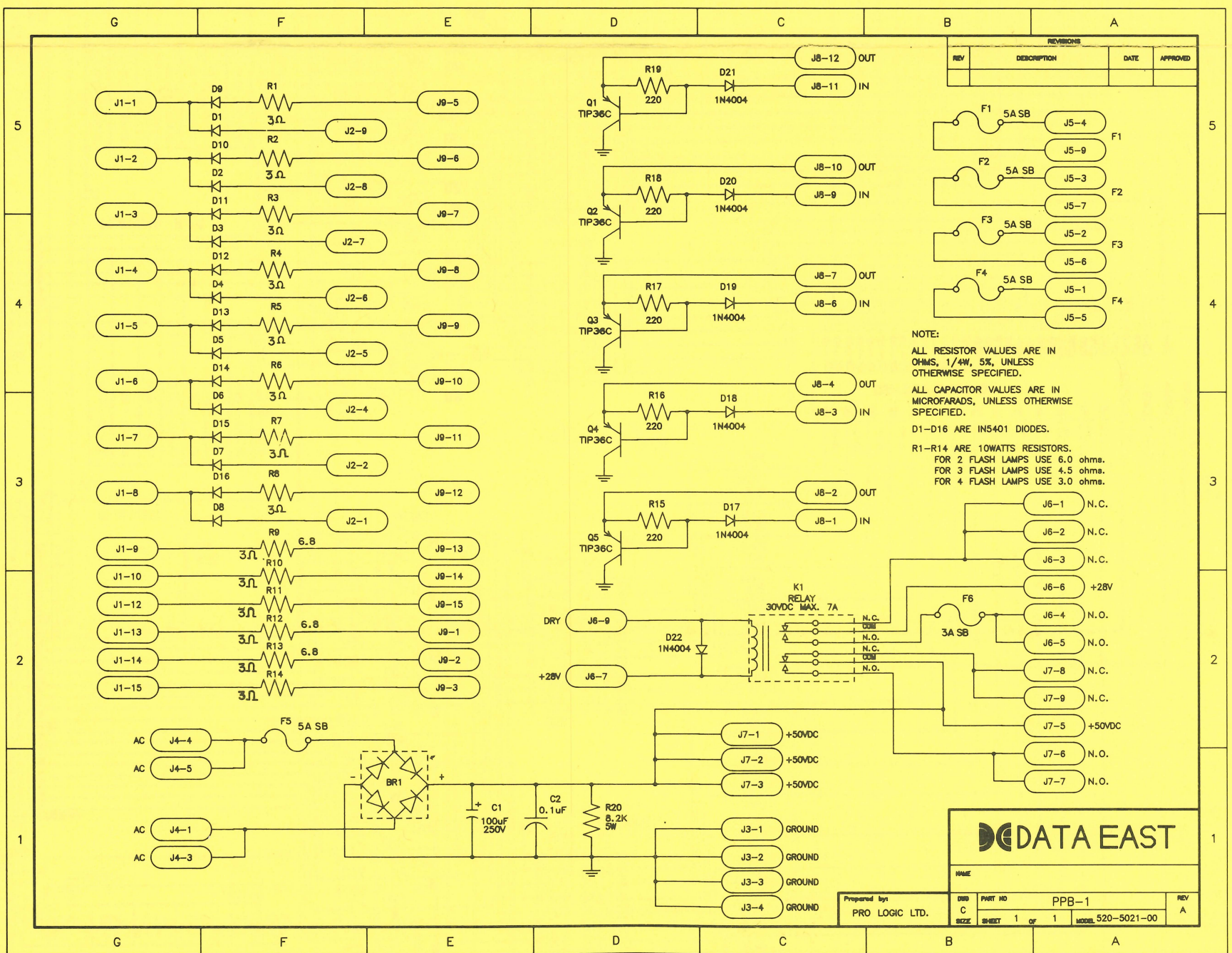
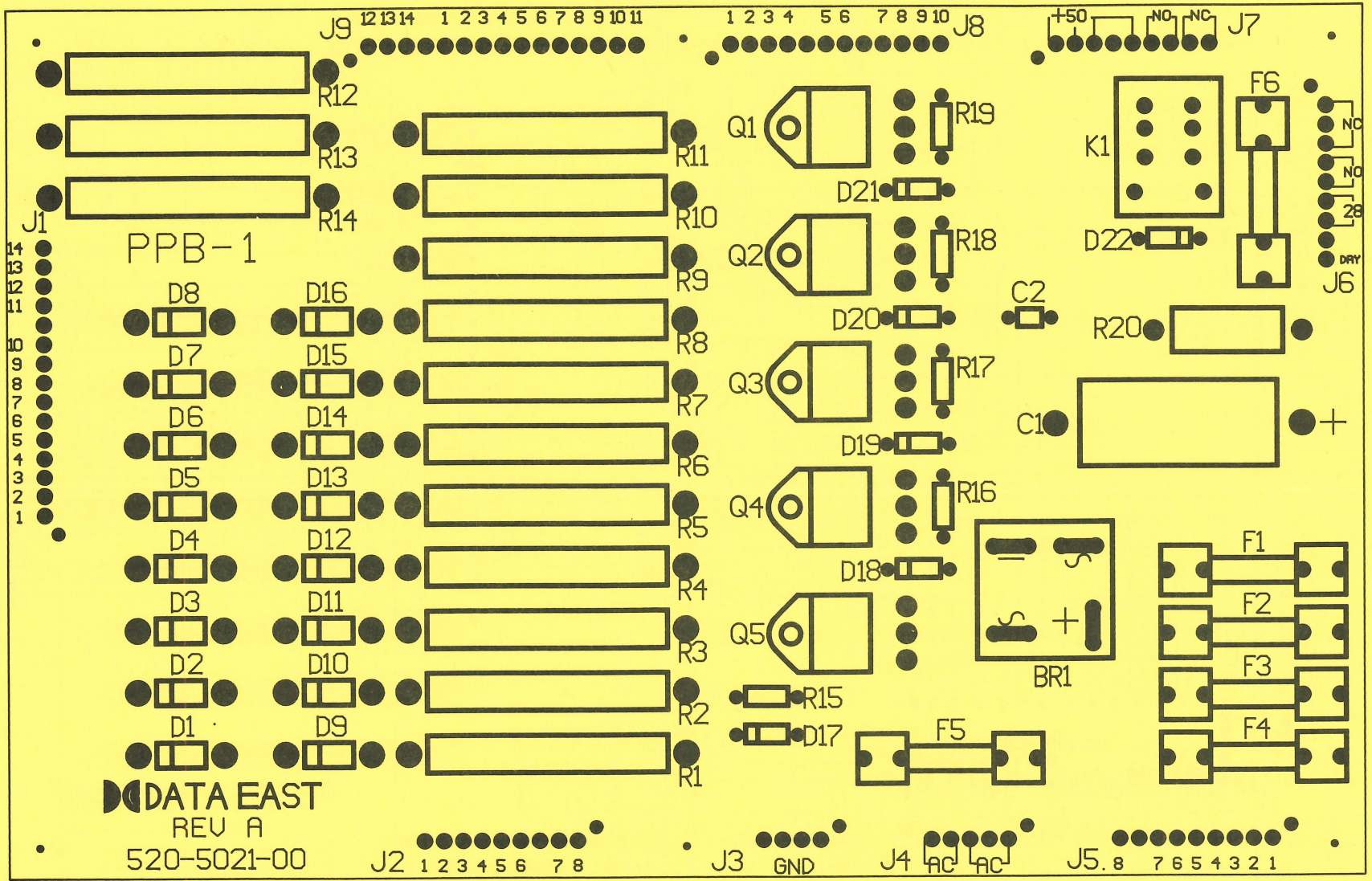



Theory of Operation for the Solid State Flippers

- The solid state flipper board is a dual flipper solenoid driver circuit. Each solenoid driver circuit contains a one shot timer, a 50V driver, and an 8V driver.

Looking at one circuit, Schmidt NAND gates U1A, U1B, and U1D make up the one shot timer. The timer length is controlled by R10, R33 and C2. The output of the timer is gated at U1C with the buffered switch input from Q6. The output of U1C controls the 50V driver circuit consisting of Q4, Q1, Q2, Q3, and D1. As long as the flipper button is activated, Q6 will keep the 8V driver circuit, SR1, on.

The 50V provides the actuation power to the flipper solenoid while the 8V provides the holding power.

Solid State Flippers PCB Wiring Diagram

Connector CN 1			
Pin #	Goes To	Wire Color	It Is
1	Rgt. Flipper Sw.	BLU-VIO	RGT. FLIP ENABLE KEY
2			
3	CPU CN10-1	WHT-GRY	SW. RET 8
4	CPU CN8-2	GRN-RED	SW. DRV 2
5	CPU CN10-2	WHT-VIO	SW. RET 7
6	CPU CN5-7	BLK	GND
7	CPU CN5-9	BLK	GND
8	PS CN6-10	GRY-WHT	+5VDC
9	Lft. Flipper Sw.	BLU-GRY	LFT. FLIP ENABLE

Connector CN 2			
Pin #	Goes To	Wire Color	It Is
1	Lft. Flip Coil	GRY-YEL	LFT. FLIP POWER
2	"" "" ""	"" "" ""	"" "" ""
3			KEY
4	Rgt. Flip Coil	BLU-YEL	RGT. FLIP POWER
5	"" "" ""	"" "" ""	"" "" ""
6	PS CN1-11	GRY	9 VAC
7	PS CN1-10	GRY-GRN	9 VAC
8	PPB J7-1	BLK-WHT	50 VDC
9	PPB J7-5	BLK-WHT	50 VDC

Solid State Flipper Wiring Diagram

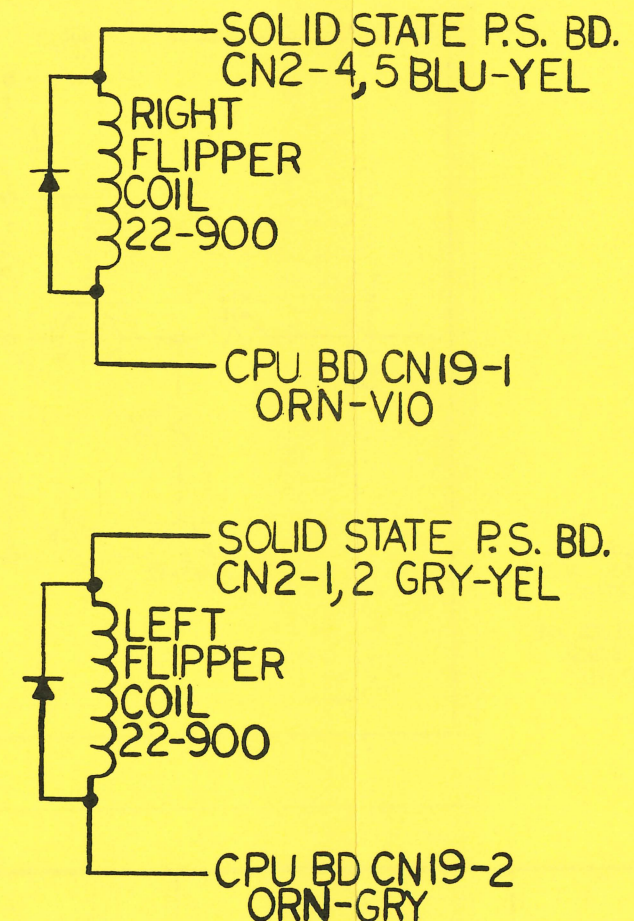
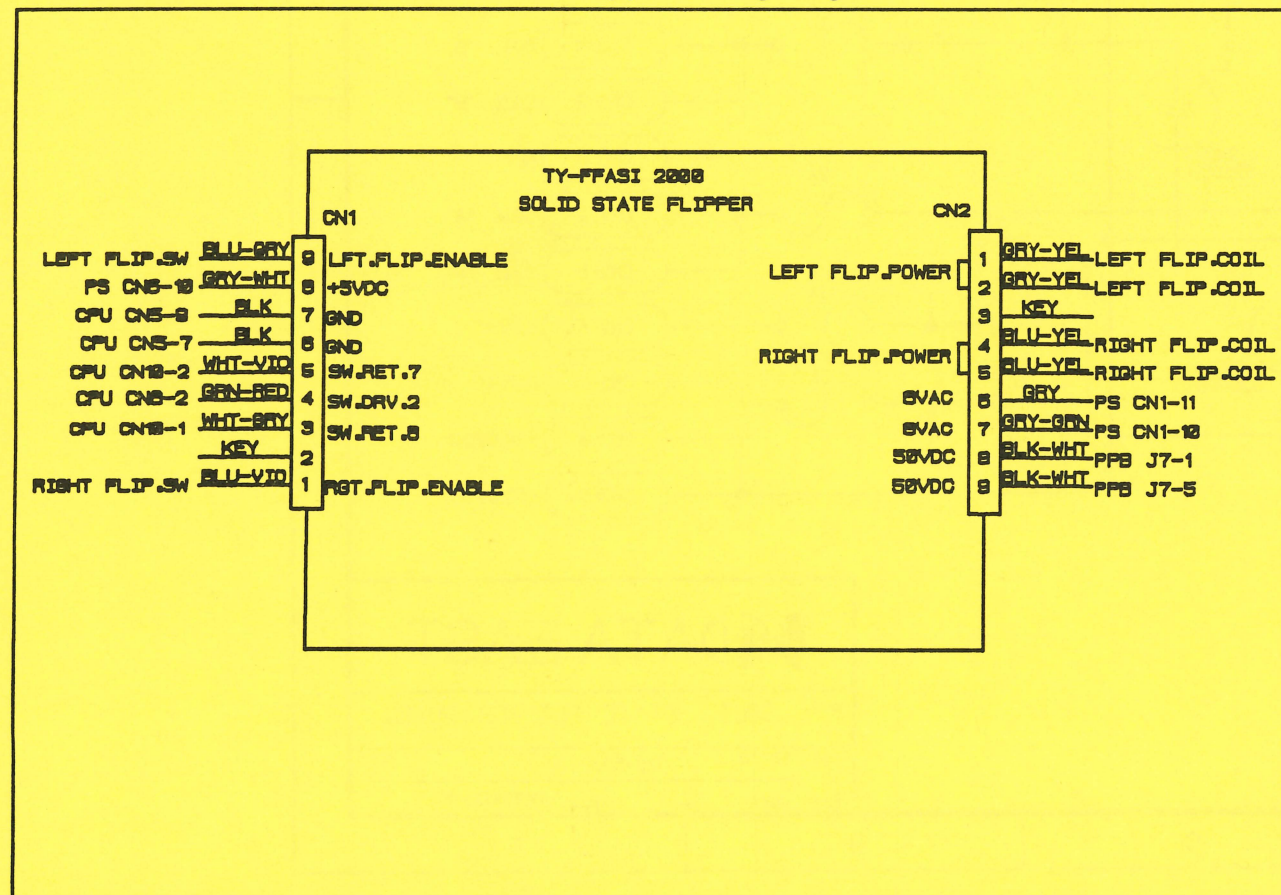

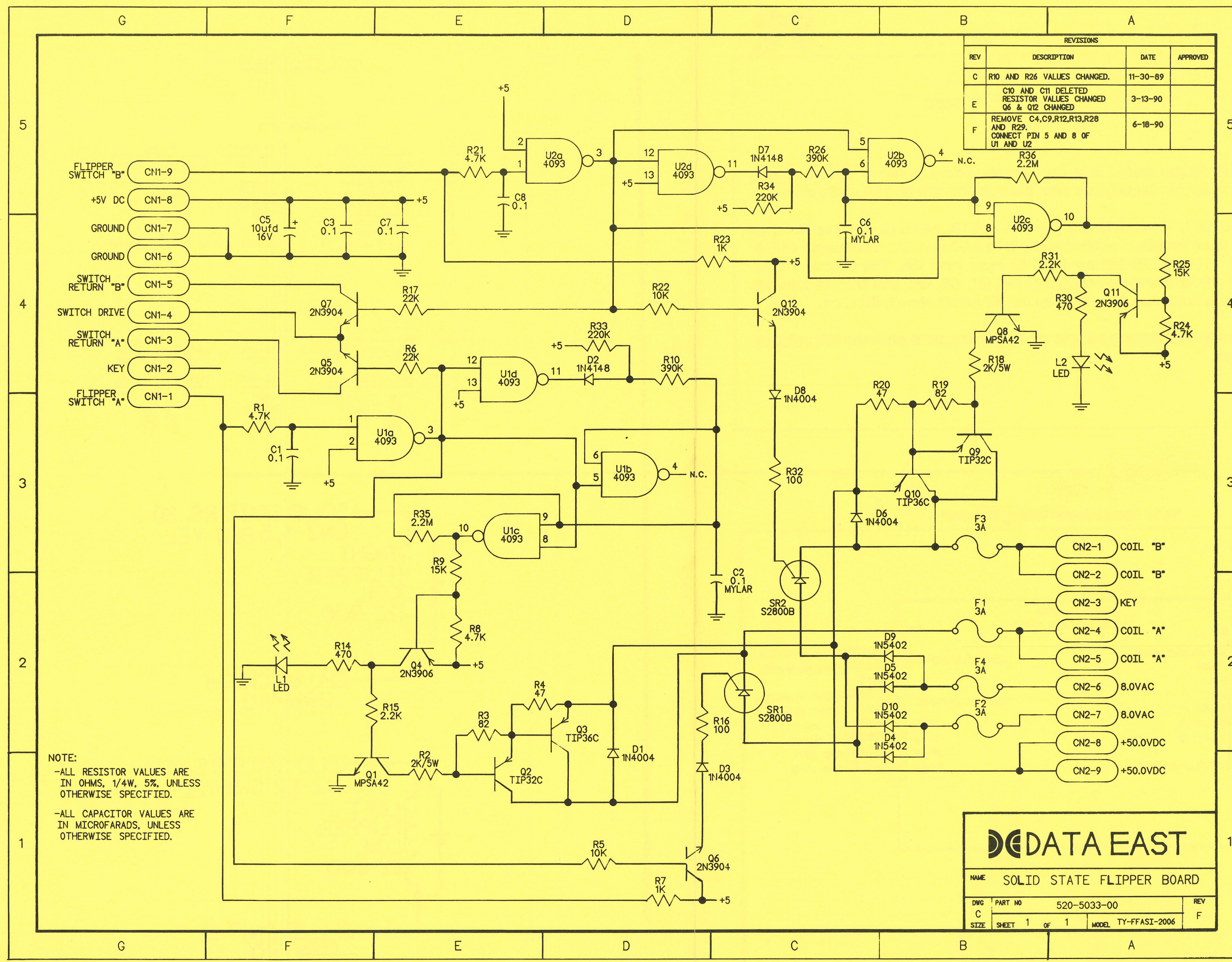

REVISIONS			
REV	DESCRIPTION	DATE	APPROVED
C	R10 AND R26 VALUES CHANGED.	11-30-89	
E	C10 AND C11 DELETED RESISTOR VALUES CHANGED Q6 & Q12 CHANGED	3-13-90	
F	REMOVE C4,C9,R12,R13,R28 AND R29. CONNECT PIN 5 AND 8 OF U1 AND U2	6-18-90	

NOTE:
 -ALL RESISTOR VALUES ARE
 IN OHMS, 1/4W, 5%, UNLESS
 OTHERWISE SPECIFIED.
 -ALL CAPACITOR VALUES ARE
 IN MICROFARADS, UNLESS
 OTHERWISE SPECIFIED.

DATA EAST

NAME: SOLID STATE FLIPPER BOARD

DWG	PART NO	REV
C	520-5033-00	F
SIZE	SHEET 1 OF 1	MODEL TY-FFASI-2006

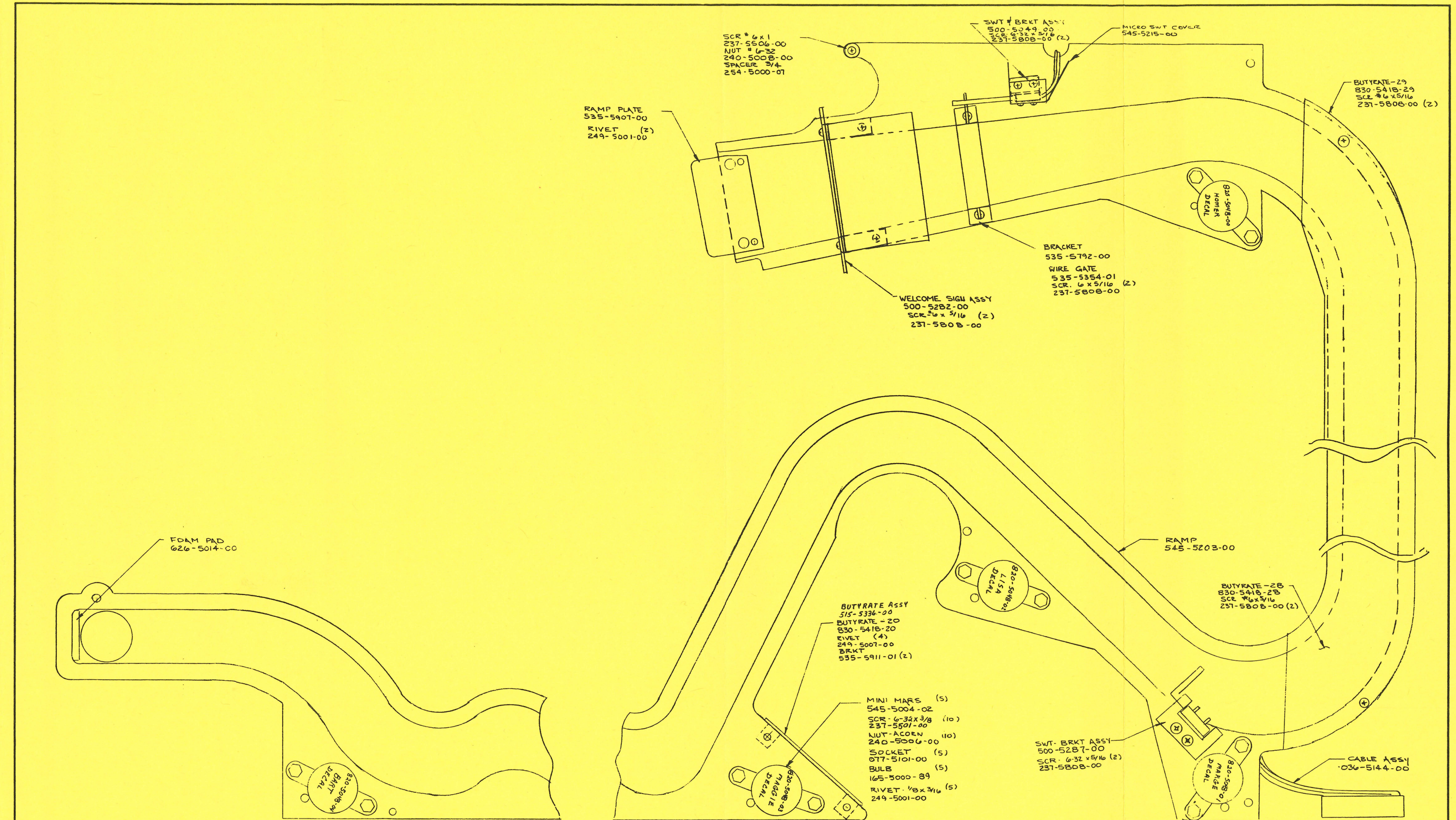

DATA EAST PINBALL, INC. 1990 JANICE AVE., MELROSE PARK, IL. 60160		
SCALE: 1:1	APPROVED BY	DRAWN BY JLL
DATE: 4-6-90		
RAMP ASSY SIMPSONS		
DRAWING NUMBER		500-5274-00

