

Bally®

April 1993
16-50020-101

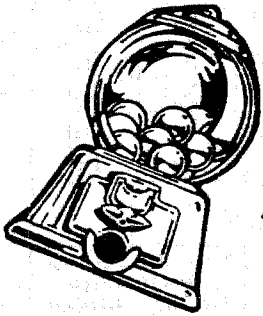
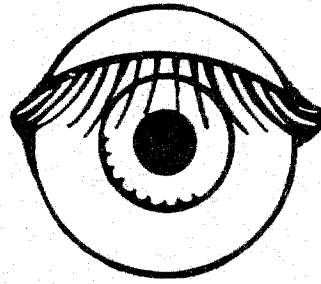

$E=mc^2$

TWILIGHT ZONE

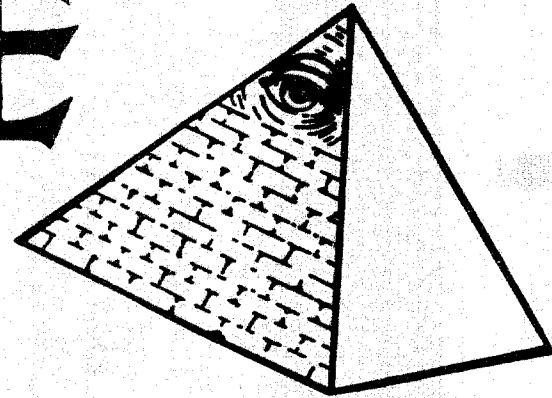
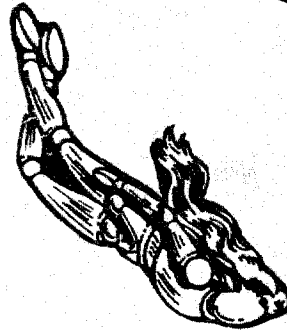
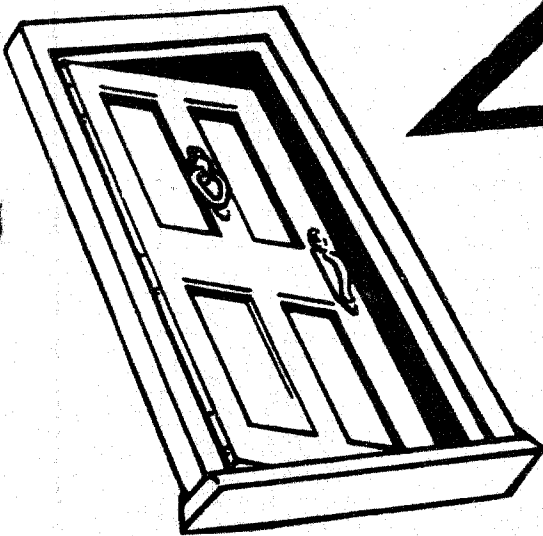

Operations Manual Includes
Operations & Adjustments
Testing & Problem Diagnosis
Parts Information
Reference Diagrams & Schematics

Midway Manufacturing Company
3401 North California Avenue
Chicago, Illinois 60618

JUMPER CHARTS

Display	W1	W2
1MEG, 2MEG, 4 MEG EPROM	In	Out
512K, 1 MEG EPROM	Out	In

Country	W14	W15	W16	W17	W18
America	In	In	In	In	In
European	In	In	Out	In	In
French	In	In	In	Out	Out
German	In	In	In	In	Out
Spain	In	Out	In	In	In

SOLENOID / FLASHER TABLE

Sol. No.	Function	Solenoid Type	Voltage Connections			Drive xister	Drive Connections			Drive Wire Color	Solenoid Part Number Flashlamp Type	
			Playfield	Backbox	Cabinet		Playfield	Backbox	Cabinet		Playfield	Backbox
01	Slot Kickout	High Power	J130-1			Q82	J107-3			Vio-Brn	AE-24-900	
02	Rocket Kicker	High Power	J130-2			Q80	J107-3			Vio-Red	AL-23-800	
03	Auto-Fire Kicker	High Power	J130-4			Q78	J107-3			Vio-Org	AL-23-800	
04	Gumball Popper	High Power	J130-5			Q76	J107-3			Vio-Yel	AE-23-800	
05	Right Ramp Diverter	High Power	J130-6			Q64	J107-3			Vio-Grn	AE-26-1200	
06	Gumball Diverter	High Power	J130-7			Q66	J107-3			Vio-Blu	AE-26-1500	
07	Knocker	High Power		J130-8		Q68		J107-3		Vio-Blk		AE-23-800
08	Outhole	High Power	J130-9			Q70	J107-3			Vio-Gry	AE-27-1200	
09	Ball Release	Low Power	J127-1			Q58	J107-2			Brn-Blk	AE-26-1200	
10	Right Slingshot	Low Power	J127-3			Q56	J107-2			Brn-Red	AE-27-1200	
11	Left Slingshot	Low Power	J127-4			Q54	J107-2			Brn-Org	AE-27-1200	
12	Lower Jet Bumper	Low Power	J127-5			Q52	J107-2			Brn-Yel	AE-26-1200	
13	Left Jet Bumper	Low Power	J127-6			Q50	J107-2			Brn-Grn	AE-26-1200	
14	Right Jet Bumper	Low Power	J127-7			Q48	J107-2			Brn-Blu	AE-26-1200	
15	Lock Release	Low Power	J127-8			Q46	J107-2			Brn-Vio	AE-27-1200	
16	Shooter Diverter	Low Power	J127-9			Q44	J107-2			Brn-Gry	SZ-33-3000	
17	Bumpers (2)	Flasher	J125-1			Q42	J107-6			Blk-Brn	#906	
18	Power Payoff (2)	Flasher	J125-2			Q40	J107-6			Blk-Red	#906	
19	Mini-Playfield (2)	Flasher	J125-3			Q38	J107-6			Blk-Org	#906	
20	Upper Left Ramp	Flasher	J125-5			Q36	J107-6			Blk-Yel	#906	
21	Left Magnet	Flasher	J125-6			Q28	J109-5			Blu-Grn	20-9247	
22	Not Used	Flasher	----			Q30	----			Blu-Blk	----	
23	Lower Right Magnet	Flasher	J125-8			Q34	J109-5			Blu-Vio	20-9247	
24	Gumball Motor	Flasher	J125-9			Q32	J107-6			Blu-Gry	14-7984	
25	Left Mini Magnet	Gen. Purpose	J124-1			Q26	J109-5			Blu-Brn	20-9247	
26	Right Mini Magnet	Gen. Purpose	J124-2			Q24	J109-7			Blu-Red	20-9247	
27	Left Ramp Diverter	Gen. Purpose	J124-3			Q22	J109-7			Blu-Org	AR-26-1500	
28	Inside Ramp	Gen. Purpose	J124-5			Q20	J107-6			Blu-Yel	#906	
37	Upper Right Flipper	Flasher	*J4-1				J107-6			Brn-Wht	#906	
38	Gumball Machine Hi	Flasher	*J4-2				J107-6			Red-Wht	#906	
39	Gumball Machine Mid	Flasher	*J4-3				J107-6			Org-Wht	#906	
40	Gumball Machine Low	Flasher	*J4-5				J107-6			Yel-Wht	#906	
41	Upper Right Ramp	Flasher	*J3-5				J107-6			Grn-Wht	#906	
42	Clock Reverse	Flasher	**J1-2				**J1-5			Blu-Wht	A-16120	
43	Clock Forward	Flasher	**J1-1				**J1-5			Vio-Wht	A-16120	
44	Clock Switch Strobe	Flasher	*J5-1				J107-6			Gry-Wht	----	

General Illumination

01	Playfield Left	G.I.	J-121-1			Q18	J-121-7			Wht-Brn	24-6549	
02	Mini-playfield & Insert	G.I.	J-121-2	J-120-2		Q10	J-121-8	J-120-8		Wht-Org	24-8768	24-8768
03	Clock & Insert	G.I.	J-121-3	J-120-3		Q14	J-121-9	J-120-9		Wht-Yel	24-8829	24-8768
04	Insert Main	G.I.		J-120-5		Q16		J-120-10		Wht-Grn		24-8768
05	Playfield Right	G.I.	J-121-6			Q12	J-121-11			Wht-Vio	24-6549	

Flipper Circuits		Voltage Connections		Drive Transistors		Drive Connections		Drive Wire Colors		Coil Part Number	Coil Colors
		Playfield	Backbox	Power	Hold	Playfield	Backbox	Power	Hold		
Lower Left Flipper	Lwr. Lt. Power	J907-7 (Gry-Yel)		Q3		J902-9		Blu-Gry		FL-15411	ORANGE
	Lwr. Lt. Hold	J907-7 (Gry-Yel)			Q9	J902-7		Org-Blu			
Lower Right Flipper	Lwr. Rt. Power	J907-9 (Blu-Yel)		Q4		J902-13		Blu-Vio		FL-15411	ORANGE
	Lwr. Rt. Hold	J907-9 (Blu-Yel)			Q11	J902-11		Org-Grn			
Upper Left Flipper	Up Lt. Power	J907-1 (Gry-Yel)		Q1		J902-3		Blk-Blu		FL-11753	YELLOW
	Up Lt. Hold	J907-1 (Gry-Yel)			Q5	J902-1		Org-Gry			
Upper Right Flipper	Up Rt. Power	J907-4 (Blu-Yel)		Q2		J902-6		Blk-Yel		FL-11722	GREEN
	Up Rt. Hold	J907-4 (Blu-Yel)			Q7	J902-4		Org-Vio			

*From 8 Driver P.C.B., A-16100

**From D.C. Motor Control Assembly, A-16120

THANK YOU FOR BUYING ANOTHER FINE BALLY PINBALL!

PLEASE READ THIS SHEET AND KEEP IT WITH THE GAME, IT CONTAINS IMPORTANT INFORMATION ON THE NEW TECHNICAL FEATURES CONTAINED IN THE TWILIGHT ZONE.

YOUR COLLECTIONS ARE OUR CONCERN!

1. Please note the TRU-PITCH™ level located on the right shooter rail. This allows you to accurately pitch the game WITHOUT REMOVING THE GLASS when it is first set in a new location. The first line on the level is approximately 6 degrees. Every line after that is approximately another 1/2 degree of pitch. We recommend you pitch TWILIGHT ZONE with the NOSE of the bubble on the second line of the level (6 1/2 degrees). We DO NOT recommend a pitch of less than 6 degrees (nose of bubble on first line). This could lead to long ball time and adverse earnings.

TRU-PITCH™ level 6 1/2 degrees.

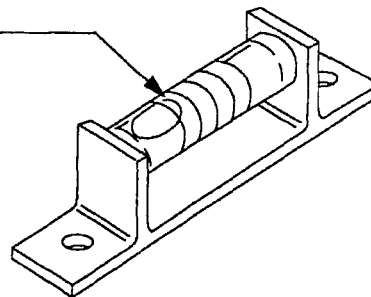

2. For the first time ever in a Bally/William's pinball, we have implemented BUY-IN. This allows your players to purchase ONE extra ball for 1 CREDIT at the end of a normal game. This is done by simply pressing the EXTRA BALL BUTTON located on the right front of the cabinet at the end of a game. Should you, for any reason, decide to disable this feature, simply go to the adjustments section of the diagnostics. At A2 (feature adjustment) adjustment 01, change the setting to OFF. We feel BUY-IN will be a valuable earnings asset for TWILIGHT ZONE.

3. Twilight Zone is shipped with 6 balls. 5 standard pinballs (steel) and one white ceramic POWERBALL. To set the game in operation simply place ALL 6 BALLS in the drain area and on powerup the game should AUTOLOAD three of them into the GUMBALL MACHINE. Besides being convenient this is a good first functional test of the Auto-loader and diverter/gumball system.

4. The POWERBALL is made from a HIGH-TECH, HIGH temperature, machine polished ceramic. It has been tested into many MILLIONS of cycles of collision etc. It is completely NORMAL for the POWERBALL to CHANGE COLOR from WHITE to a pearlescent color as it ages. This in no way effects its playability or the ability of the game to detect its presence on the playfield! CLEANING of the POWERBALL is not recommended.

5. Note the new area of the manual which contains UNIT DISASSEMBLY INSTRUCTIONS for the major playfield areas and individual components. We hope this will be a major help in future service.

ATTENTION TO OUR 5 BALL OPERATORS!!!!!!

BEFORE placing The TWILIGHT ZONE on location we HIGHLY RECOMMEND that the adjustable outlane posts be moved UP to their most open position! This will shorten ball time slightly, so as to balance the game play more favorably with 3 ball play, for maximum earnings and longevity.

AT BALLY WE'RE WORKING FOR YOUR BOTTOM LINE!

Twilight Zone

Midway Manufacturing Company reserves the rights to make modifications and improvements to its products.

The specifications and parts identified in this manual are subject to change without notice.

Table of Contents

Game Rules	A
Section 1 - Game Operation & Test Information	1-1
(System WPC) ROM Summary	1-1
Pinball Game Assembly Instructions	1-2
Pinball Assembly, Playfield Pitch Angle and Leg Levelers Detail	
How to Raise the Playfield	1-5
Game Control Locations	1-6
Game Operation	1-7
Menu System Operation and Main Menu	1-8
Bookkeeping Menu	1-9
B.1 Main Audits	1-9
B.2 Earnings Audits	1-9
B.3 Standard Audits	1-10
B.4 Feature Audits	1-11
B.5 Histograms	1-12
B.6 Time-Stamps	1-12
Printouts Menu	1-13
Test Menu	1-14
T.1 Switch Edges Test	1-14
T.2 Switch Levels Test	1-14
T.3 Single Switch Test	1-14
T.4 Solenoid Test	1-15
T.5 Flasher Test	1-15
T.6 G.I. Tests	1-15
T.7 Sound and Music Test	1-16
T.8 Single Lamp Test	1-16
T.9 All Lamps Test	1-16
T.10 Lamp and Flasher Test	1-16
T.11 Display Test	1-16
T.12 Flipper Coil Test	1-17
T.13 Ordered Lamp Test	1-17
T.14 Clock Test	1-18
T.15 Gumball Test	1-20
T.16 Magnet Test	1-22
Utilities Menu	1-23
U.1 Clear Audits	1-23
U.2 Clear Coins	1-23
U.3 Reset H.S.T.D	1-23
U.4 Set Time & Date	1-23
U.5 Custom Message	1-23
U.6 Set Game I.D	1-24
U.7 Factory Adjustments	1-24
U.8 Factory Reset	1-24
U.9 Presets	1-24
Game Difficulty Table for U.S./Canada/France	1-25
Game Difficulty Table for Germany/Europe	1-25
Preset Table U.S./Canada	1-26
Preset Table Germany/Europe	1-28
Preset Table France	1-28
U.10 Clear Credits	1-28
U.11 Auto Burn-In	1-28
Adjustment Menu	1-29
A.1 Standard Adjustments	1-29
A.2 Feature Adjustments	1-33
A.3 Pricing Adjustments	1-39
Pricing Table	1-41

A.4 H.S.T.D. Adjustments.....	1-42
A.5 Printer Adjustments.....	1-43
Error Messages.....	1-44
CPU Board, Sound Board Error Codes & Opto Theory.....	1-45
LED List.....	1-46
Fuse List.....	1-47
Maintenance Information.....	1-48
Unit Disassembly for Repair.....	1-49
Clock Removal.....	1-50
Clock Gear Train Assembly.....	1-51
Main Right Steel Ramp Removal.....	1-52
Main Right Steel Ramp Chute Removal.....	1-52
Gumball Machine Removal.....	1-54
Gumball Wire Entry Removal.....	1-54
Main Left Plastic Ramp Assembly Removal.....	1-56
Mini-playfield (Powerfield) Removal.....	1-58
Optical 3 Ball Lock Assembly Removal.....	1-59
Notes.....	1-60

Section 2 - Game Parts Information.....	2-1
Line Filter/Cordset Chart.....	2-2
Cabinet Parts.....	2-3
Backbox Assembly.....	2-4
Fliptronic II Board.....	2-5
Audio Board.....	2-6
CPU Board.....	2-8
Power Driver Board.....	2-10
Dot Matrix Controller Board.....	2-12
Coin Door Interface Board.....	2-14
Flipper Opto Board.....	2-14
8-High Power Driver P.C.B. Assembly.....	2-15
D.C. Motor Control Assembly.....	2-15
8-Driver P.C.B. Assembly.....	2-16
Trough Coil Assembly.....	2-16
Minute Opto P.C.B. Assembly.....	2-17
Hour Opto P.C.B. Assembly.....	2-17
Ramp Proximity Opto Sensor Assembly.....	2-18
Proximity Opto Sensor Assembly.....	2-18
Motor EMI Board.....	2-19
10-Switch Opto P.C.B. Assembly.....	2-19
Fliptronic II Flipper Assembly.....	2-20
Outhole Kicker Assembly.....	2-22
Ball Shooter Lane Feeder Assembly.....	2-23
Kicker Arm (Slingshot) Assembly.....	2-24
Ball Popper Assembly.....	2-25
Bridge Diverter Assembly.....	2-26
Right Diverter Assembly.....	2-27
Rear Diverter Assembly.....	2-28
Shooter Diverter Assembly.....	2-29
Gumball Machine.....	2-30
Clock Assembly.....	2-32
Eject Assembly.....	2-34
Knocker Assembly.....	2-34
Kicker Assembly.....	2-35
Coil Magnet & Bracket Assemblies.....	2-35
Kicker Assembly V-Pad.....	2-36
Coil & Bracket Assembly.....	2-36
Ball Shooter Assembly.....	2-37
Switch & Plate Assembly.....	2-37

Tilt Mechanism Assembly	2-38
3-Bank Target Assembly	2-38
Jet Bumper Assembly	2-39
Jet Bumper Coil Assembly	2-39
Mini-Playfield Parts	2-40
Coin Door Assembly	2-42
Unique Parts List	2-44
Cable List	2-45
Posts	2-46
Lower Playfield Parts	2-47
Upper Playfield Parts	2-48
Switch Matrix	2-50
Switch Locations	2-50
Solenoid/Flasher Table	2-52
Solenoid/Flasher Locations	2-53
Lamp Matrix	2-54
Lamp Locations	2-55
Rubber Parts Locations	2-56
Ramp Locations	2-57

Section 3 - Wiring Diagrams and Schematics	3-1
Component Identification	3-1
Switch Matrix & Circuit Drawings	3-2
Lamp Matrix & Circuit Drawing	3-4
Solenoid/Flasher Table	3-5
Solenoid Wiring	3-6
Flasher Wiring	3-7
Solenoid/Flasher Circuit Drawing	3-8
Notes	3-11
8 Driver P.C.B. Assembly	3-12
8 Driver P.C.B. Schematic	3-13
8 High Power Driver P.C.B. Assembly	3-14
8 High Power Driver P.C.B. Schematic	3-15
Custom Opto SW10 P.C.B. Assembly	3-16
Custom Opto SW10 P.C.B. Assembly	3-17
Minute Opto P.C.B.	3-18
Hour Opto P.C.B.	3-19
Ramp Proximity Opto Sensor Assembly	3-20
Proximity Sensor Board	3-21
D.C. Motor Control Assembly	3-22
Motor EMI Board Assembly	3-23
Flipper Opto Switch Board	3-24
Flipper Circuit Diagrams	3-25
Fliptronic II Board Wiring	3-28
CPU Board Wiring	3-29
Coin Door Interface Wiring	3-30
Coin Door Interface Schematic	3-31
Power Driver Board Wiring	3-32
Sound Board Wiring	3-35
Dot Matrix Controller Board Wiring	3-36

Twilight Zone

Game Rules

OBJECT: Explore the strange world of the Twilight Zone. **BATTLE THE POWER** using **MAGNA-FLIP™**. Try to Unlock **THE DOOR** by lighting all of the **DOOR PANELS**. Stop **TIME** by using **THE CLOCK**.

EXTRA BALLS: Shoot the ball multiple times around The **LEFT RAMP** to light extra ball.

MULTI-BALL™: Spell **GUM-BALL** by shooting the **LEFT** and **RIGHT** ramps. **LOCK** balls by shooting into the **LOCK AREA** located above the **PLAYER PIANO**.

THE DOOR: Shooting the **LEFT RAMP** lights the **PLAYER PIANO**. Shooting the **RIGHT RAMP** lights the **SLOT MACHINE**. The **PLAYER PIANO** awards the currently **FLASHING DOOR PANEL**. The **SLOT MACHINE** awards a **RANDOM DOOR PANEL**.

POWER BALL: Get the **POWER BALL** out of the **GUMBALL MACHINE** by shooting up the right side of the game when the **GUMBALL ARROW** is flashing. When the **WHITE POWER BALL** is on the playfield **RETURN IT** to the **GUMBALL MACHINE** to begin **POWER BALL MANIA**. In **POWER BALL MANIA** shoot at the right ramp to **BATTLE THE POWER!**

BUY EXTRA BALL: At the end of a game you may buy 1 extra ball for 1 credit. All features and score remain as they were at end of game!

Game Operation and Test Information

(System WPC) ROM Summary

IC	TYPE	BOARD	LOCATION	PART NUMBER
Game ROM 1	27040	CPU	U6	A-5343-50020-1
Music/Speech EPROM	27010	Audio	U14	A-5343-50020-6
Music/Speech EPROM	27040	Audio	U15	A-5343-50020-7
Music/Speech EPROM	27040	Audio	U18	A-5343-50020-8

NOTICE

Order replacement ROMs from your authorized MIDWAY MANUFACTURING CO. distributor. Specify: (1) part number (if available); (2) ROM level (number) on the label; (3) game in which ROM is used.

PINBALL GAME ASSEMBLY INSTRUCTIONS

TWILIGHT ZONE IS A 6 BALL GAME.

<u>Power:</u>	Domestic 120V @ 60 Hz Foreign 230V @ 50 Hz Japan 100V @ 50Hz	<u>Dimensions:</u>	Width: 29" Approx. Depth: 55" Approx. Height: 76" Approx.
<u>Temp:</u>	32° F to 100° F (0° C to 38° C)	<u>Weight:</u>	Approx. 322 lbs. (crated)
<u>Humidity:</u>	Not to exceed 95% relative.		

1. Remove all cartons, parts, and miscellaneous items from the shipping container and set them aside.
2. Place the cabinet on a support and attach rear legs using leg bolts. Leg levelers and leg bolts are provided among the parts in the cash box.
3. Attach the front legs (after installing leg levelers), using leg bolts. See diagram below.

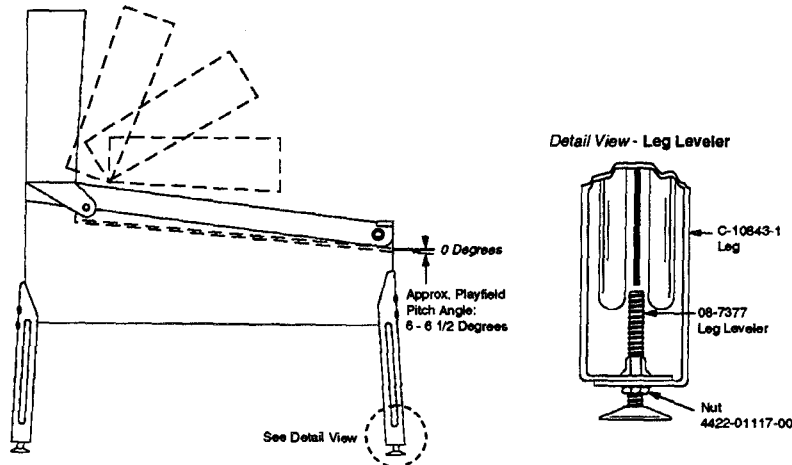

4. Reach into the cabinet and backbox and ensure that the interconnecting cables are not kinked or pinched. Be careful to avoid damaging wires at any stage of the assembly process.
5. Raise the hinged backbox upright and latch it into position. Unlock the backbox, and remove the backglass, storing it carefully to avoid scratches. Remove the shipping block holding the Insert Board. Unlatch and open the Insert Board. Carefully lift the Speaker Panel and lay it down on the playfield glass. Be careful not to damage the Dot Matrix Display/Driver Board. This allows access to the bolt holes used for securing the backbox upright. Install the washer-head mounting bolts through the bottom holes of the backbox into the threaded fasteners in the cabinet to secure the backbox. Close the Insert Board and latch it in position. Replace the Speaker Panel. Reinstall the backglass, and lock the backbox.



CAUTION

FAILURE TO INSTALL the backbox mounting hardware properly can cause personal injury. **NEVER TRANSPORT** a pinball game with the hinged backbox erect. Always lower the backbox forward onto the playfield cabinet on a layer of protective material to prevent marring or damage and possible personal injury.

6. Extend each leg leveler slightly below the leg bottom, so that all four foot pads protrude approximately the same distance. Remove the cabinet from its support and place it on the floor.
7. Unlock and open the coin door. Move the molding latch lever toward the left side of the game, to release the front molding. Lift the front molding off the playfield cover glass, return the latch lever to the right, and close the coin door. Carefully slide the glass downward, until it clears the grooves of the left and right side moldings. Lift the glass up and away from the game, storing it carefully to avoid breakage.
8. Place a level or an inclinometer on the playfield surface. Adjust the leg levelers for proper playfield level (side-to-side). NOTE: It is recommended that these measurements be made ON the playfield, not the cabinet nor the playfield cover glass. Tighten the nut on each leg leveler shaft to maintain this setting.
9. The TRU-PITCH™ level is located on the right shooter rail. This allows the playfield pitch angle to be accurately adjusted WITHOUT REMOVING THE GLASS. The first line (closest to the front of game) on the level is approximately 6 degrees. Every line thereafter is approximately another 1/2 degree of pitch. The recommended pitch for Twilight Zone is 6 1/2 degrees. The NOSE of the bubble should be between the first and second line on the level (see diagram below).

TRU-PITCH™ level 6 1/2 degrees.

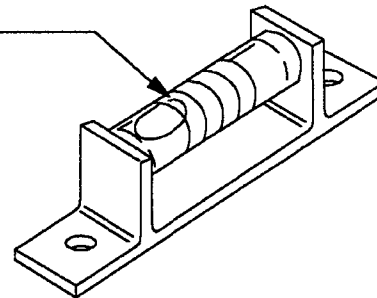

CAUTION

Playfield pitch angle adjustments can affect the operation of the plumb bob tilt, inside the cabinet. The plumb bob weight is among the parts in the cash box; the operator should install the weight and adjust this tilt mechanism for proper operation, after completion of the desired playfield pitch angle setting. The unit is factory installed for a 6 1/2 degree angle. If an adjustment is necessary, loosen the screw at the bottom of the unit. Move the pointer, one groove at a time to the left or right, depending on the degree desired. Hold the pointer in place and tighten screw.

10. Move the game into the desired location; recheck the level and pitch angle of the playfield.
11. Verify that the **required number** of balls are installed in the game. **Twilight Zone** uses 6 balls, 3 in the ball trough and 3 in the gumball machine. All six balls (5 steel and 1 white) may be placed in the lower trough. The game will automatically load three balls into the gumball machine.
12. Remove foam insert used to support the lamp assembly in shipping, just above the mini-playfield.

13. Install playfield mylars if desired.

NOTE: **Twilight Zone** playfield is coated with a special hardcoat surface and does not require a protective mylar. However, playfield mylars can be purchased through your local Bally Distributor. Specify part number 03-7960-50020-1 for full playfield mylar.

14. Clean and reinstall the playfield cover glass, reversing the procedure of step 7.

15. To attach line cord, remove envelope stapled to the inside cabinet (near cashbox). Remove the four Phillips-head screws that mount the line cord cover plate to the rear cabinet. Match the prongs on the plug with the holes in the receptacle and push line cord securely into place. Make sure cord is aligned with the indentation of plate (indentation should point toward bottom of cabinet). Remount line cord cover plate. If desired, tamper resistant screws have been provided in an envelope marked "Security Screws" (located in cashbox) to remount cover plate. Prepare the game for player operation.

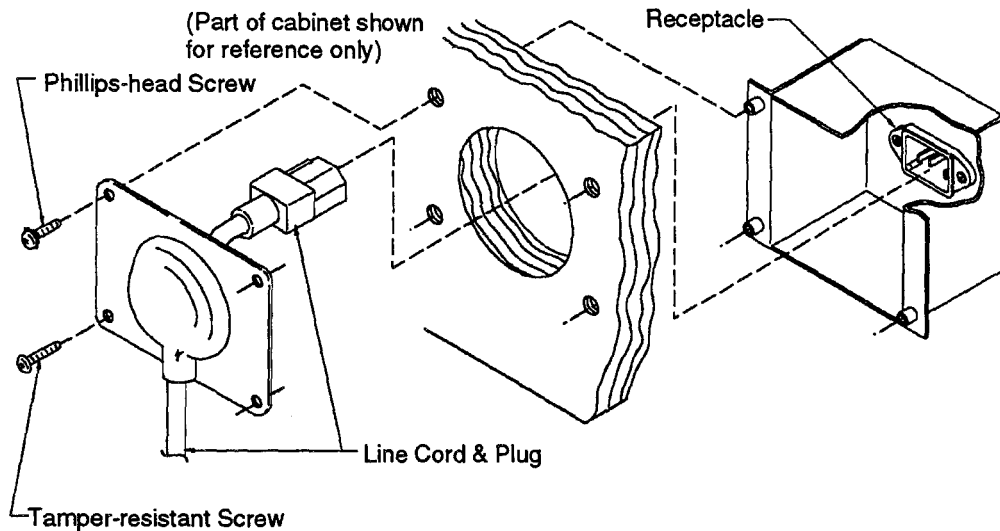

RAISING THE PLAYFIELD

CAUTION

Do not raise the playfield straight up! This game uses a slide assembly to raise and lower the playfield.

To raise the playfield.

1. Grasp bottom arch and carefully lift up playfield only high enough to clear safety brackets. Rear guide legs should not hit wood guide rails or be used to slide out playfield.

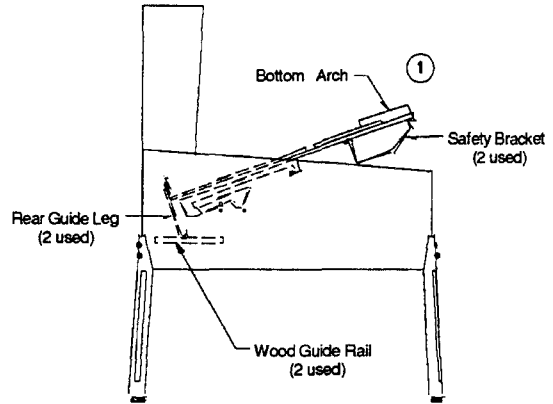

2. Pull the playfield out toward you until it stops (rest position) and raise it approximately 3".

Be sure playfield is in locked position and does not slide back into the cabinet. If it does, repeat Step 2 before proceeding to Step 3.

3. Rotate playfield to upright service position (lean on backbox) by pulling toward you and up. Listen for the sound of a click; this insures locking and pivoting sequence.

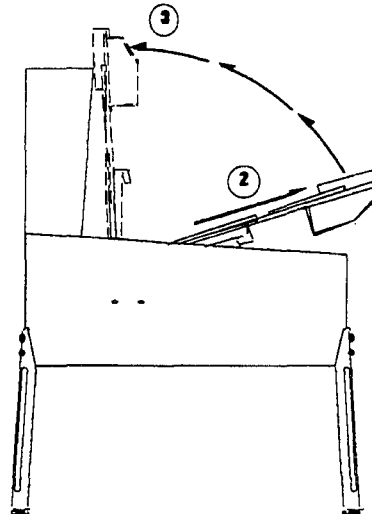

To lower the playfield.

4. Rotate the playfield to the rest position. This unlocks the pivoting mechanism.
5. Push back playfield into cabinet and into playing position.

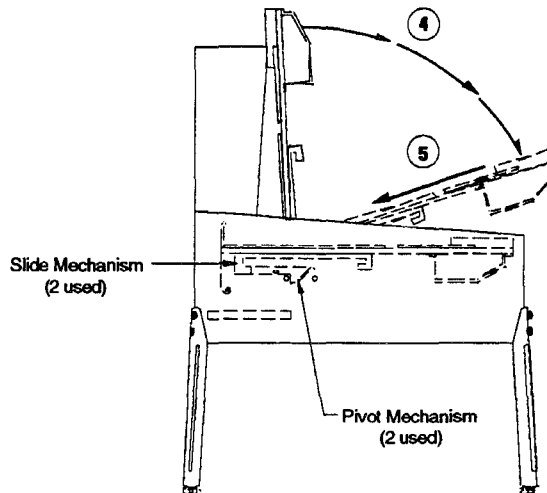

GAME CONTROL LOCATIONS

Cabinet Switches

The On-Off switch is located on the bottom of the cabinet near the right front leg.

The Start Button is the push-button to the left of the coin door on the cabinet exterior. Press the Start button to begin a game, or during the diagnostic mode, to ask for HELP.

Coin Door Switches

The operator controls all game adjustments, obtains bookkeeping information, and diagnoses problems, using only four push-button switches mounted on the inside of the coin door. The Coin Door Switches have two modes of operation Normal Function and Test Function.

Normal Function

The Service Credits button puts credits on the game that are not included in any of the game audits.

The Volume Up (+) button raises the sound level of the game. Press and hold the button until the desired level is reached.

The Volume Down (-) button lowers the sound level of the game. Press and hold the button until the desired level is reached. See Adjustment A.1 28 to shut sound OFF completely.

The *Begin Test button starts the Menu System Operation and changes the Coin Door Switches from Normal Function to Test Function.

Test Function

The Escape button allows you to get out of a menu selection or return to the Attract Mode.

The Up (+) button allows you to cycle forward through the menu selections or adjustment choices.

The Down (-) button allows you to cycle backward through the menu selections or adjustment choices.

The *Enter button allows you to get into a menu selection or lock in an adjustment choice.

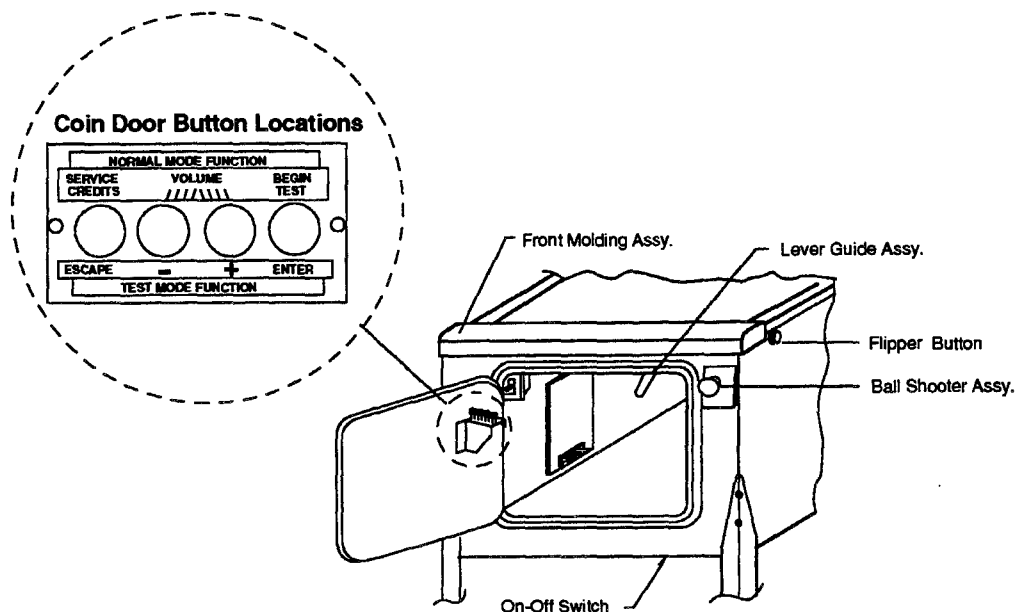

****To reset High Score, hold down the Begin Test/Enter switch for 5 seconds while in the Attract Mode.***

GAME OPERATION

CAUTION

After assembly and installation at the site location, this game must be plugged into a properly grounded outlet to prevent shock hazard, and to assure proper game operation. DO NOT use a 'cheater' plug to defeat the ground pin on the line cord. DO NOT cut off the ground pin.

POWERING UP. With the coin door closed, plug the game in and switch it On. In normal operation, testing will show in the display as the game performs Start-Up Tests. Once the Start-Up Tests have been successfully completed the last score is displayed. Afterward, the game goes into the Attract Mode.

Note: After the game has been on location for a period of time, the Start-Up Tests may contain messages concerning game problems. See 'Error Messages' for more detailed information regarding messages.

Open the coin door and press the Begin Test Switch. The display shows the game name, number, and software revision. The message changes. The display shows the sound software revision, revision level of the system software and date the game software was revised.

Example: **Twilight Zone** **Sound Rev. L-1**
 50020 **Rev. P-B** **Sy. 2.53** **2/18/93**

Press the Enter button to enter the WPC Menu System (refer to the section entitled 'Menu System Operation' for more information). Perform the entire Test Menu routine to verify the game is operating satisfactorily.

ATTRACT MODE*. After completing the Test Menu routine, press the Escape button three times to enter the Attract Mode. During the Attract Mode the display shows a series of messages informing the player of the recent highest scores*, "custom messages*", and the score to achieve to obtain a replay award*

CREDIT POSTING. Insert coin(s). A sound is heard for each coin and the display shows the number of credits purchased. So long as the number of maximum allowable credits* are NOT exceeded by coin purchase or high score, credits are posted correctly.

STARTING A GAME. Press the Start button once. A startup sound plays and the credit amount shown in the display decreases by one. The display flashes 00 (until the first playfield switch is actuated), and shows ball 1. If credits are posted, additional players may enter the game by pressing the Start button once for each player, before the end of play on the first ball.

TILTS. Actuating the Slam Tilt switch inside the cabinet ends the current game and proceeds to the Game Over Mode. With the third closure* of the plumb bob tilt switch, the player loses the remaining play of that ball, but can complete the game.

END OF GAME. All earned scores and bonuses are awarded. If a player's final score exceeds the specified value, the player receives a designated award for achieving the current highest score. A random digit set* appears in the display. Credit* may be awarded when the last two digits of any player's score match the random digits. Match, high score, and game over sounds are made, as appropriate.

GAME OVER MODE. Game Over will show in the display. Afterward, the high scores flash on the display. The game proceeds to the Attract Mode.

*Operator-adjustable feature.

MENU SYSTEM OPERATION

This game operates on a Menu System. The Main Menu allows you to choose from several main categories, which in turn lead to other menus to choose from. To enter the Menu System, open the coin door and press the Begin Test button. The displays show the Game I.D. Mode. Press the Enter button and the Main Menu appears. To cycle through the Main Menu selections press either the Up or Down button. Activate any selection by pressing the Enter button when the desired selection appears in the displays. Return to the Attract Mode or a previous menu selection, press the Escape button. Press the Start button for HELP at any time.

Main Menu

B. Bookkeeping Menu	
	B.1 Main Audits
	B.2 Earnings Audits
	B.3 Standard Audits
	B.4 Feature Audits
	B.5 Histograms
	B.6 Time-Stamps
P. Printouts Menu	
	P.1 Earnings Data
	P.2 Main Audits
	P.3 Standard Audits
	P.4 Feature Audits
	P.5 Score Histograms
	P.6 Game Time Histograms
	P.7 Time-Stamps
	P.8 All Data
T. Test Menu	
	T.1 Switch Edges
	T.2 Switch Levels
	T.3 Single Switches
	T.4 Solenoid Test
	T.5 Flasher Test
	T.6 General Illumination
	T.7 Sound & Music Test
	T.8 Single Lamps
	T.9 All Lamps
	T.10 Lamp & Flasher Test
	T.11 Display Test
	T.12 Flipper Test
	T.13 Ordered Lamp Test
	T.14 Clock Test
	T.15 Gumball Test
	T.16 Magnet Test
U. Utilities Menu	
	U.1 Clear Audits
	U.2 Clear Coins
	U.3 Reset H.S.T.D.
	U.4 Set Time & Date
	U.5 Custom Message
	U.6 Set Game I.D.
	U.7 Factory Adjustments
	U.8 Factory Resets
	U.9 Presets
	U.10 Clear Credits
	U.11 Auto Burn-In
A. Adjustments Menu	
	A.1 Standard Adjustments
	A.2 Feature Adjustments
	A.3 Pricing Adjustments
	A.4 H.S.T.D. Adjustments
	A.5 Printer Adjustments

Press Escape

To move out of a menu selection.

Press Enter

To get into a menu selection.

Press Up

Increases sequence; Example A.1, A.2, A.3, A.4.

Press Down

Decreases Sequence; Example A.4, A.3, A.2, A.1.

Use Up and Down to cycle through the selections in a menu.

Use Escape and Enter to move into and out of the selected menu

Bookkeeping is the first category available from the Main Menu. Press the Enter button to activate the Bookkeeping Menu. Press the Up or Down button to cycle through the selections. Press the Enter button to activate a selection. Once activated, press the Up or Down button to cycle through the available audits. Audits cannot be set, they can only be cleared by using U1 and U2 from the Utilities Menu. Press the Escape button to return to the Bookkeeping Menu. Press it again to return to the Main Menu.

B. BOOKKEEPING MENU

- B.1 Main Audits**
- B.2 Earning Audits**
- B.3 Standard Audits**
- B.4 Feature Audits**
- B.5 Histograms**
- B.6 Time-Stamps**

One Button Audit System. The Bookkeeping Menu is obtainable directly from the Attract Mode. Repeatedly pressing the Enter button, while in the Attract Mode, will cycle through all of the game audits.

B.1 Main Audits

B.1	01	Total Earnings	00
B.1	02	Recent Earnings	00
B.1	03	Free Play Percent	00
B.1	04	Average Ball Time	00
B.1	05	Time Per Credit	00
B.1	06	Total Plays	00
B.1	07	Replay Awards	00
B.1	08	Percent Replays	00
B.1	09	Extra Balls	00
B.1	10	Percent Extra Ball	00

B.2 Earning Audits*

B.2	01	Recent Earnings	00
B.2	02	Recent Left Slot	00
B.2	03	Recent Center Slot	00
B.2	04	Recent Right Slot	00
B.2	05	Recent 4th Slot	00
B.2	06	Recent Paid Credits	00
B.2	07	Recent Service Credits	00
B.2	08	Total Earnings*	00
B.2	09	Total Left Slot*	00
B.2	10	Total Center Slot*	00
B.2	11	Total Right Slot*	00
B.2	12	Total 4th Slot*	00
B.2	13	Total Paid Credits*	00
B.2	14	Total Service Credits*	00

*These audits are NOT resettable. They are a record of the earnings of the game since the "CLOCK 1ST SET" Time-Stamp.

B.3 Standard Audits

B.3	01	Games Started	00
B.3	02	Total Plays*	00
B.3	03	Total Free Play	00
B.3	04	Free Play Percent	00
B.3	05	Replay Awards	00
B.3	06	Percent Replays	00
B.3	07	Special Awards	00
B.3	08	Percent Special	00
B.3	09	Match Awards	00
B.3	10	Percent Match	00
B.3	11	H.S.T.D. Credits	00
B.3	12	Percent H.S.T.D	00
B.3	13	Extra Ball	00
B.3	14	Percent Extra Ball	00
B.3	15	Tickets Awarded	00
B.3	16	Percent Tickets	00
B.3	17	Left Drains	00
B.3	18	Right Drains	00
B.3	19	Average Ball Time	00
B.3	20	Time Per Credit	00
B.3	21	Play Time	00:00:00
B.3	22	Minutes On	00
B.3	23	Balls Played	00
B.3	24	Tilts	00
B.3	25	Replay 1 Awards	00
B.3	26	Replay 2 Awards	00
B.3	27	Replay 3 Awards	00
B.3	28	Replay 4 Awards	00
B.3	29	1 Player Games	00
B.3	30	2 Player Games	00
B.3	31	3 Player Games	00
B.3	32	4 Player Games	00
B.3	33	H.S.T.D. Reset Count	00
B.3	34	Burn-in Time †	00:00:00
B.3	35	1st Replay Level	00
B.3	36	Left Flipper	00
B.3	37	Right Flipper	00

* "Total Plays" only counts completed games. A game is considered complete when the final ball begins. Audit information from incomplete games is ignored, therefore test and servicing operations do not affect the Audits.

† This Audit is not resettable.

B.4 Feature Audits

B.4	01	Buy-In Extra Balls	00
B.4	02	1st Gumball	00
B.4	03	1st Lock Games	00
B.4	04	1st Multiball	00
B.4	05	2nd Multiball	00
B.4	06	3rd Multiball	00
B.4	07	Total Multiballs	00
B.4	08	White Multiballs	00
B.4	09	Multi Restart	00
B.4	10	Jackpots	00
B.4	11	Double Jackpots	00
B.4	12	Gumballs Loaded	00
B.4	13	Powerball Played	00
B.4	14	Powerball Mania	00
B.4	15	Powerball Mania Jackpot	00
B.4	16	Door Awards	00
B.4	17	Slot Awards	00
B.4	18	Piano Awards	00
B.4	19	Door Extra Ball	00
B.4	20	Lost In the Zone	00
B.4	21	Fastlock Multiballs	00
B.4	22	Fastlock Jackpot	00
B.4	23	Spiral Extra Ball	00
B.4	24	Dead End Extra Ball	00
B.4	25	Robot 1st Extra Ball	00
B.4	26	Robot 2nd Extra Ball	00
B.4	27	Left Drain Extra Ball	00
B.4	28	Battle the Power	00
B.4	29	Power Defeated	00
B.4	30	Town Square Award	00
B.4	31	Dead End Award	00
B.4	32	Hitch-Hikers	00
B.4	33	Triple Pickups	00
B.4	34	Camera Awards	00
B.4	35	Skill Shots	00
B.4	36	Super Skill Shots	00
B.4	37	Bonus X	00
B.4	38	Spiral Awards	00
B.4	39	Left Ramps	00
B.4	40	Right Ramps	00
B.4	41	3-Way Combo	00
B.4	42	4-Way Combo	00
B.4	43	Free Rides	00
B.4	44	Buy-In Free Ride	00
B.4	45	Zone Champ Credit	00

B.5 Histograms

B.5	01	0-4.9 Million Scores	00%	00
B.5	02	5-9.9 Million Scores	00%	00
B.5	03	10-19 Million Scores	00%	00
B.5	04	20-39 Million Scores	00%	00
B.5	05	40-59 Million Scores	00%	00
B.5	06	60-89 Million Scores	00%	00
B.5	07	90-119 Million Scores	00%	00
B.5	08	120-149 Million Scores	00%	00
B.5	09	150-199 Million Scores	00%	00
B.5	10	200-249 Million Scores	00%	00
B.5	11	250-349 Million Scores	00%	00
B.5	12	350-499 Million Scores	00%	00
B.5	13	Over 500 Million	00%	00
B.5	14	Game Time 0.0-1.0 Mins	00%	00
B.5	15	Game Time 1.0-1.5 Mins	00%	00
B.5	16	Game Time 1.5-2.0 Mins	00%	00
B.5	17	Game Time 2.0-2.5 Mins	00%	00
B.5	18	Game Time 2.5-3.0 Mins	00%	00
B.5	19	Game Time 3.0-3.5 Mins	00%	00
B.5	20	Game Time 3.5-4.0 Mins	00%	00
B.5	21	Game Time 4-5 Mins	00%	00
B.5	22	Game Time 5-6 Mins	00%	00
B.5	23	Game Time 6-8 Mins	00%	00
B.5	24	Game Time 8-10 Mins	00%	00
B.5	25	Game Time 10-15 Mins	00%	00
B.5	26	Game Time Over 15 Mins	00%	00

B.6 Time-Stamps

The Time-Stamps Menu allows you to view dates and times that are important to game software.

B.6	01	Current Time
B.6	02	Clock 1st Set
B.6	03	Clock Last Set
B.6	04	Audits Cleared
B.6	05	Coins Cleared
B.6	06	Factory Setting
B.6	07	Last Game Start
B.6	08	Last Replay
B.6	09	Last H.S.T.D. Reset
B.6	10	Champion Reset
B.6	11	Last Printout
B.6	12	Last Service Credit

Press the Enter button to activate the Printouts Menu, once the menu name is shown under the Main Menu. Then, use the Up or Down button to cycle through the Printouts Menu selections. Press the Enter button to activate the desired Printouts group. Press again to return to the Main Menu.

P. PRINTOUTS MENU

(optional board required)

- P.1 Earnings Data**
- P.2 Main Audits**
- P.3 Standard Audits**
- P.4 Feature Audits**
- P.5 Score Histograms**
- P.6 Time Histograms**
- P.7 Time-Stamps**
- P.8 All Data**

The Printouts Menu is a combination of the other menus. This menu allows you to access and print information in the available menu selections.

If no printer is attached the message "Waiting for Printer" appears in the displays.
Note: Set print specification from the Adjustment Menu, A.5 Printer Adjustments.

Press the Enter button to activate the Test Menu, once the menu name is shown under the Main Menu. Then, use the Up or Down button to cycle through the Test Menu selections. Press the Enter button to activate a test. Press the Escape button to return to the Test Menu. Press again to return to the Main Menu. Note: During any test, press the Start button (Help) to obtain the wire color, driver number, connector number, and fuse location.

T. TEST MENU

T.1	Switch Edges
T.2	Switch Levels
T.3	Single Switch
T.4	Solenoid Test
T.5	Flasher Test
T.6	General Illumination
T.7	Sound & Music Test
T.8	Single Lamps
T.9	All Lamps
T.10	Lamp & Flasher Tests
T.11	Display Test
T.12	Flipper Test
T.13	Ordered Lamps Test
T.14	Clock Test
T.15	Gumball Test
T.16	Magnet Test

The switch matrix, on the left side of the display, shows the state of all switches. A dot indicates the switch is open, and a square indicates the switch is closed. The numbers assigned to each switch indicate where the switch is located in the matrix. The number on the left indicates the column, and the number on the right indicates the row. Example: Switch 23 is 2nd column, 3rd row.

A short to ground, on either the row or column wire, appears as a shorted row(s). However, a column wire shorted to ground disappears when all the indicated row switches are open. A row wire shorted to ground does not disappear.

A shorted diode in the switch matrix can cause other switches to appear closed. These "phantom" switches (though not actually closed) complete a rectangle in the switch matrix. Therefore, if two switches in the same column are closed (example; #22 and #24), and a third switch is pressed in another column but in the same row as one of the first two (example; #32), the "phantom" switch #34 is falsely indicated as closed. The switch with the shorted diode is diagonally opposite the "phantom" switch (in this case #22).

T.1 Switch Edges Press each switch one at a time. The name and number of the switch is shown in the display. If a switch other than the one pressed, or no switch at all is indicated, the system has detected a problem with the switch circuit.

T.2 Switch Levels This test automatically cycles through all switches that are detected closed. The name and number of each switch that is detected is shown in the display. A filled square indicates the switch's position in the matrix.

T.3 Single Switches The Single Switch Test isolates a particular switch by blocking signals from all other switches. Use the Up or Down buttons to select the switch to be tested.

T.4 Solenoid Test The Solenoid Test has three modes: Repeat, Stop, and Run. Only one solenoid should pulse at a time. The system has detected a problem if; more then one solenoid pulses, a solenoid comes On and stays On, or during the Repeat or Run modes, no solenoid pulses.

- Repeat - The Repeat Mode pulses a single solenoid. After entering this test, Solenoid 1 shows in the display. and the corresponding solenoid activates. Press the Up or Down button to cycle through the solenoids, one at a time. The same solenoid pulses until the Up or Down button is pressed. Either press the Escape button to return to the Test Menu, or press the Enter button to advance to the next mode.
- Stopped - The Stopped Mode halts the Solenoid Test. Press Enter during the Repeat mode and the Solenoid Test Stops. No solenoids should be activated while the test is stopped. Either press the Escape button to return to the Test Menu, or the Enter button to advance to the next mode.
- Running - The Running Mode cycles through the solenoids automatically. The display shows the name and number of the solenoid currently being pulsed. Either press the Escape button to return to the Test Menu, or the Enter button to advance to the next mode.

T.5 Flasher Test This tests the flashlamp part of the solenoid circuit exclusively. This, like the Solenoid Test has three test modes: Repeat, Stop, and Run. During this test, only one flashlamp circuit should pulse at a time. The system has detected a problem if more than one circuit pulses, a circuit stays On, or during the Repeat or Run modes, no circuit pulses.

- Repeat - The Repeat mode pulses a single flashlamp. After entering this test, the name and number of the first flashlamp circuit will show in the display and the corresponding bulb(s) flash. Press the Up or Down button to cycle through all of the flashlamp circuits one at a time. The same circuit pulses until the Up or Down button is pressed. Either press the Escape button to return to the Test Menu, or press the Enter button to advance to the next mode.
- Stopped - The Stopped Mode halts the Flasher Test. No flashlamp circuit should be active during this mode. Either press the Escape button to return to the Test Menu, or the Enter button to advance to the next mode.
- Running - The Running Mode cycles through the flashlamps automatically. The display shows the name and number of the flashlamp circuit currently being pulsed and the corresponding bulb(s) flash. Either press the Escape button to return to the Test Menu, or the Enter button to advance to the next mode.

T.6 General Illumination This test checks all of the General Illumination circuits. There are two modes of operation: Stop and Run.

- Stopped - Press the Up or Down buttons to cycle through the General Illumination Test manually. All illumination is tested first, followed by an individual circuit test. The circuit name and number will show in the display while the corresponding lamps light. If any other results occur the system has detected an error.
- Running - Press the Enter button any time during Stopped mode and the General Illumination Test cycles through automatically. For each circuit shown in the displays the corresponding bulbs should light. If any other results occurs the system has detected a problem.

T.7 Sound and Music Test The Sound and Music Test allows you to check the audio circuits. This test has three modes for testing the sound and music circuits: Run, Repeat, and Stop.

- Running - The Running Mode steps through a sequence of sounds and music. Pressing the Up or Down button during this portion of the Sound and Music test advances to a particular sound/tune without having to wait for the program to play all the sounds available in the test. A sound/tune should be heard for each name and number that appears in the display. Any other results indicate the system has detected a problem.
- Repeat - Press the Enter button at any time during the Running Mode to cause the program to stop and repeat a particular sound/tune. The same sound should repeat continuously until the Up or Down button is pressed. Any other results indicates the system has detected a problem.
- Stopped - Press the Enter button at any time during the Repeat Mode to stop this test altogether. No sound/tune should be heard. Any other results indicates the system has detected a problem.

T.8 Single Lamp Test The number assigned to each lamp indicates the lamp's position in the matrix. The number on the left indicates the column. The number on the right indicates the row. Example: Lamp 23 means 2nd column, 3rd row.

This test checks each lamp circuit individually. Press the Up or Down button to cycle through this test. For each name and number that is shown in the display the corresponding lamp should light. Any other results indicate the system has detected a problem.

T.9 All Lamps Test This test causes all the controlled lamps to flash at the same time. Every controlled lamp should flash. Any other results indicate the system has detected a problem.

T.10 Lamp and Flasher Test This test causes all the flashlamps and the controlled lamps to flash at the same time. The controlled lamps blink, while the flashlamps cycle from highest to lowest. Any other results indicates the system has detected a problem.

T.11 Display Test This test automatically lights every dot in the Dot Matrix Display. A series of patterns appear in sequence. Each pattern turns On and Off a section of dots. Every dot on the display should be turned On and Off during this test.

T.12 Flipper Coil Test The Flipper Coil Test has three modes: Repeat, Stop, and Run. Only one flipper should pulse at a time. The system has detected a problem if; more then one flipper pulses, a flipper comes On and stays On, or during the Repeat or Run modes, no flipper pulses.

- Repeat - The Repeat Mode pulses a single flipper. After entering this test, coil 01 shows in the display and the corresponding flipper activates. Press the Up or Down button to cycle through the flipper coils, one at a time. The same flipper coil pulses until the Up or Down button is pressed. Either press the Escape button to return to the Test Menu, or press the Enter button to advance to the next mode.
- Stopped - The Stopped Mode halts the Flipper Coil Test. Press Enter during the Repeat mode and the Flipper Coil Test stops. No flipper coil should be activated while the test is stopped. Either press the Escape button to return to the Test Menu, or the Enter button to advance to the next mode.
- Running - The Running Mode cycles through the flippers automatically. The display shows the name and number of the flipper coil currently being pulsed. Either press the Escape button to return to the Test Menu, or the Enter button to advance to the next mode.

T.13 Ordered Lamp Test The number assigned to each lamp indicates the lamp's position in the matrix. The number on the left indicates the column. The number on the right indicates the row. Example - Lamp 23 means 2nd column, 3rd row.

This test checks each lamp circuit individually. Press the Up or Down button to cycle through the lamps. Lamps light in a clock-wise or counter clock-wise direction starting from the bottom of the playfield. Direction depends on which button, Up or Down, is pressed. For each name and number that is shown in the display the corresponding lamp should light. Any other results indicates the system has detected a problem.

T.14 Clock Test This test may be used to test the mechanical clock in the game.

There are 8 opto sensors used to monitor the position of the clock hands. These 8 sensors are wired in as a 9th column in the switch matrix. The column drive is the Gray-White wire attached to pin J5-1 of the 8-Driver P.C.B. Assembly, pt #A-16100, (located on the left side-wall of the backbox). This column is driven by Q1 and Q12 of the 8-Driver Board. The switch matrix row connections are made to the normal white "row" switch matrix wires. This 9th column is shown on the far right of the switch matrix, in the clock test:

	<u>Column 9 (Gry-Wht)</u>
Row 1 (Wht- Brn)	15 minutes
Row 2 (Wht- Red)	0 minutes
Row 3 (Wht- Org)	45 minutes
Row 4 (Wht- Yel)	30 minutes
Row 5 (Wht- Grn)	Hour 1
Row 6 (Wht- Blu)	Hour 2
Row 7 (Wht- Vio)	Hour 3
Row 8 (Wht- Gry)	Hour 4

The clock is operated through a D.C. Motor Control Board, pt #A-16120, (located UNDER the playfield at approximately the same position as the clock) and solenoid drives 42 and 43 (located on the 8-Driver Board in the backbox). With only drive 43 turned ON, the clock moves forward. With only drive 42 turned ON, the clock moves in reverse. With both drives ON, or both drives OFF, the clock is stopped.

Using the clock test program: The top line will show the current operation. Use the red "+" and "-" coin door buttons to select one of the following functions:

- Clock Forward Slow
- Clock Forward Fast
- Clock Reverse Slow
- Clock Reverse Fast

Pressing the "Enter" button will "start" and "stop" the selected operation.

The display will indicate the state of the switch matrix and the clock, as shown below:

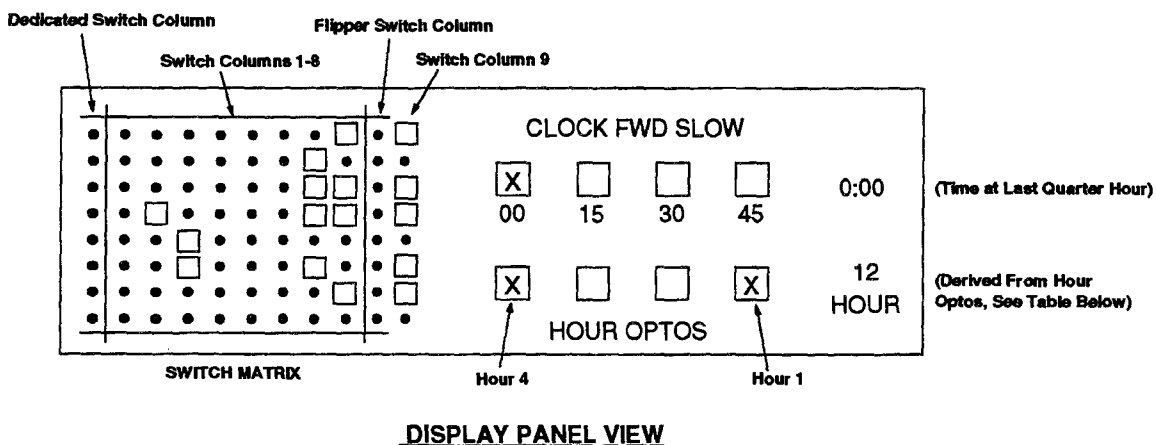

The 4 "quarter hour" optos are broken by the minute hand as it passes the quarter hour marks. The "hour" optos change as the minute hand is near the 30 minute opto. The 4 "hour" optos are examined when the minute hand passes through the "00 minutes" opto.

The following table shows how the hour optos are decoded into the "derived" hour. If this is a different value than the clock shows (with the minute hand near "00") then use the table to find the faulty opto:

Hour 4	Hour 3	Hour 2	Hour 1	Derived Hour
X			X	12
			X	1
				2
	X			3
X	X			4
X	X		X	5
	X		X	6
	X	X	X	7
	X	X		8
		X		9
		X	X	10
X		X	X	11

T.15 Gumball Test The Gumball Test may be used to test all of the ball cycling capabilities of your Twilight Zone Pinball Machine. The display shows the 12 critical switches that are involved in the ball cycling:

LOWER SWITCHES:

- Outhole - This is the switch at the bottom of the game that is closed by balls draining between the flippers.
- Trough - These four switches hold the balls in the lower trough. The four boxes left to right on the display represent the four trough switches (from left to right respectively).
- Auto-fire - This is the opto for the auto-fire kicker located just to the left of the ball shooter.

UPPER SWITCHES:

- Spiral - This is the opto that detects the ball passing over the right spiral magnet. This opto is used to signal the diverter to open and allow the ball into the gumball machine.
- Lane - This is a rollover micro switch that lets the game know that the ball has gotten beyond the diverter and is on its way to the ball popper.
- Popper - This opto tells the ball popper to kick the ball up into the gumball machine.
- Geneva - This switch is closed by the gumball motor cam to let the game know that the motor has completed a "dispense gumball" cycle.
- Exit - This is the rollover switch outside the gumball machine that lets the game know that a gumball has left the machine.

The Gumball Test has two types of operations: Automatic and Manual. The automatic operations occur as the result of the action of balls on the playfield. The Manual operations are the result of operator pressing the "Enter" button.

Automatic Operations:

Reload gumball from playfield:

Any ball that is sent up the right spiral lane during gumball test will be diverted and loaded into the gumball machine.

The display will show "LOADING GUMBALL MACHINE...". The following switches will be seen in the following order:

SPIRAL, LANE, POPPER, ENTRY

Reload gumball(s) from trough:

Any time there are more than 3 balls at the bottom of the game (in the trough and/or outhole), the game will reload all excess balls into the gumball machine (this will happen during gumball test, game over, OR game play).

The trough will serve a ball to the auto-fire kicker. The kicker will kick the ball through the gumball diverter, and the popper will load this ball into the gumball machine.

Manual Operations:

The manual operations are selected by using the "+" and "-" coin door buttons. The name of the operation will appear on the top line of the display. Press the "Enter" button to begin the selected operation.

CONTINUOUS TEST

This will continuously empty the gumball machine, then load up to 3 balls into the gumball machine. It will do this until an error is encountered or until the "Escape" button is pressed.

DISPENSE 1 GUMBALL

This will dispense 1 gumball from the gumball machine. During correct operation, you will see the "Geneva" switch, followed by the "Exit" switch as the gumball rolls out onto the playfield.

EMPTY GUMBALL MACHINE

This will dispense all balls from the gumball machine.

LOAD 1 GUMBALL

This will load 1 ball from the lower trough into the gumball machine.

Errors:

NO BALLS FOUND IN MACHINE

This error occurs during the Continuous Test when it cannot find any balls to cycle through the gumball machine.

CHECK GUMBALL ENTRY OPTO

This error occurs if the gumball machine entry opto is not seen after kicking a ball from the gumball popper.

CANNOT AUTO-LOAD. CHECK AUTO-FIRE

This error occurs if the auto-fire kicker does not get its ball into the gumball machine 4 times in a row.

CHECK GENEVA SWITCH

This error occurs if the geneva switch is not seen on the dispense of a gumball.

CHECK EXIT SWITCH

This error occurs if the geneva switch and camera switch are seen in a gumball dispense, without the exit switch ever making.

NO BALL IN TROUGH TO LOAD

This error occurs when a request to load a ball into the gumball machine is made while there are no balls in the trough.

CANNOT AUTO-LOAD CHECK BALL SERVE

This error occurs during the Continuous Test if the game cannot seem to get the balls from the trough to the auto-fire kicker.

CHECK BALL POPPER

This error occurs when the ball popper opto appears to be continuously interrupted. This condition will occur if the opto is disconnected, or if a 12V fuse is blown (F115, F116).

CHECK AUTO-FIRE KICKER

This error occurs when the auto-fire kicker opto appears to be continuously interrupted. This condition will occur if the opto is disconnected, or if a 12V fuse is blown (F115, F116).

T.16 Magnet Test The Magnet Test assists in troubleshooting any problems with the under-playfield magnets. During the test, all four magnets are enabled. The magnets are activated differently, depending upon the magnet.

Spiral Magnets

The two magnets in the outer loop (called the "SPIRAL") each have an optical switch associated with them. When a ball is sensed by the switch, the magnet is activated for a few seconds, and then deactivated. This causes the ball to be caught and held by the magnet, and then released.

The display during this test shows the states of the magnets and their optical switches. The boxes next to the labels "L. SPIR. MAG." (Left Spiral Magnet) and "R. SPIR. MAG." (Right Spiral Magnet) are filled in when the corresponding magnet is activated. The boxes next to the labels "L. SPIR. SW." (Left Spiral Switch) and "R. SPIR. SW." (Right Spiral Switch) are filled in when the corresponding switch is active.

Mini-Playfield Magnets

The magnets attached to the mini-playfield are activated by the flipper switches. The flippers themselves are turned OFF during the Magnet Test.

Pressing the left or right flipper button causes the left or right mini-playfield magnet, respectively, to be activated. The magnets are pulsed for a short time, just as during normal game play.

The display shows the states of the flipper buttons and the mini-playfield magnets. The boxes next to the labels "L. MINI. MAG." (Left Mini-playfield Magnet) and "R. MINI. MAG." (Right Mini-playfield Magnet) are filled in when the corresponding magnet is pulsed. The boxes next to the labels "L. FLIP. SW." (Left Flipper Switch) and "R. FLIP. SW." (Right Flipper Switch) are filled in when the corresponding flipper button is pressed.

Press the Enter button to activate the Utilities Menu, once the menu name is shown under the Main Menu. Then, use the Up or Down button to cycle through the Utility Menu selections. Press the Enter button to activate a selection. Use the Up or Down button to rotate the settings. Press the Enter button to lock in a setting. If a mistake is made while changing a setting, press the Escape button while "Saving Adjustment Value" is still in the display. The original setting is retained and the new setting is ignored. Press the Escape button to return to the Utilities Menu. Press it again to return to the Main Menu.

U. UTILITIES MENU

U.1	Clear Audits
U.2	Clear Coins
U.3	Reset H.S.T.D.
U.4	Set Time & Date
U.5	Custom Message
U.6	Set Game I.D.
U.7	Factory Adjustments
U.8	Factory Resets
U.9	Presets
U.10	Clear Credits
U.11	Auto Burn-in

U.1 Clear Audits Press the Enter button to clear the Standard Audits (except Burn-In Time), Feature Audits, and Histograms.

U.2 Clear Coins Press the Enter button to clear the Earnings Audits.

U.3 Reset H.S.T.D. Press the Enter button to clear the High Score to Date Table and the Grand Champion.

U.4 Set Time and Date Press the Enter button to activate the time and date. Use the Up or Down button to change the value, then press the Enter button to lock in that value. If a mistake is made, press the Escape button while "Saving Adjustment Value" is displayed. The new value is ignored and the original value is retained.

U.5 Custom Message Set A.1 20 to YES before writing a Custom Message. Press the Enter button to begin entry of the custom message. Use the Up or Down button to cycle through letters. Use the Start button to cycle through punctuation marks. Press the Enter button to lock in the desired letter and punctuation. If you make a mistake, use Up and Down to select the "back-arrow" character. The "back-arrow" character is located before the space character and after the number nine. Press Enter while the back-arrow shows to erase the previously entered character. Once your message is complete, press and hold the Enter button until "Message Stored" is displayed.

Press the Escape button to cancel the new message. The message "Press Enter to Reset" appears. If you press Enter, the custom message is cleared and no message is displayed. If Escape is pressed, the original message remains intact.

U.6 Set Game I.D. This utility allows the operator to install a message, such as game location, that only appears on printouts . Press the Enter button to activate Set Game I.D.. Use the Up or Down button to cycle through letters. Use the Start button to cycle through punctuation marks. Press the Enter button to lock in the desired letter and punctuation.

U.7 Factory Adjustment Press the Enter button to restore the adjustments to factory settings.

U.8 Factory Reset Press the Enter button to restore the adjustments to their factory setting, clear the Audits, H.S.T.D Table, and Custom Message/Game I.D.

U.9 Presets Use the Up or Down buttons to cycle through the available Presets. When the desired Preset is displayed, press the Enter button to lock in that Preset. If a mistake is made, press the Escape button while "Saving Adjustment Value" is displayed. The new value is ignored and the original value is retained.

Game Difficulty Levels The game play difficulty adjustments can be changed to a combination that is MUCH LESS to MUCH MORE difficult than Factory Settings. The Game Difficulty Setting Table lists the adjustments and settings that comprise the individual groups.

U.9 01 Install Extra Easy MUCH LESS difficult than factory setting.

U.9 02 Install Easy Somewhat LESS difficult than factory setting.

U.9 03 Install Medium About the SAME as factory setting.

U.9 04 Install Hard Somewhat MORE difficult than factory setting.

U.9 05 Install Extra Hard MUCH MORE difficult than factory setting.

Game Difficulty Setting Table for U.S./Canadian/French Games

Adj. No.	Adjustment Description	Extra Easy U.9 01	Easy U.9 02	Medium U.9 03	Hard U.0 04	Extra Hard U.9 05
A.2 11	1st Hard Lock	2	2	2	2	2
A.2 12	2nd Hard Release	3	3	3	3	3
A.2 13	Last Ramp Release	2	1	1	1	1
A.2 14	Last Easy Release	1	1	1	0	0
A.2 15	Door Spots	3	2	1	1	0
A.2 16	Piano Difficulty	EASY	EASY	EASY	MEDIUM	MEDIUM
A.2 17	Slot Difficulty	EASY	EASY	EASY	MEDIUM	MEDIUM
A.2 18	Spiral Start	EASY	EASY	EASY	EASY	HARD
A.2 19	1st Hard Spiral	5	4	1	1	1
A.2 20	Spiral Lane Memory	YES	YES	NO	NO	NO
A.2 21	Ramps for Camera	8	9	10	10	10
A.2 23	Power at Start	YES	YES	NO	NO	NO

Game Difficulty Setting Table for German/European Games

Adj. No.	Adjustment Description	Extra Easy U.9 01	Easy U.9 02	Medium U.9 03	Hard U.0 04	Extra Hard U.9 05
A.2 11	1st Hard Lock	2	2	2	2	2
A.2 12	2nd Hard Release	3	3	3	3	3
A.2 13	Last Ramp Release	2	1	1	1	1
A.2 14	Last Easy Release	1	1	1	0	0
A.2 15	Door Spots	3	2	1	1	0
A.2 16	Piano Difficulty	EASY	EASY	EASY	MEDIUM	MEDIUM
A.2 17	Slot Difficulty	EASY	EASY	EASY	MEDIUM	MEDIUM
A.2 18	Spiral Start	EASY	EASY	EASY	EASY	HARD
A.2 19	1st Hard Spiral	5	4	1	1	1
A.2 20	Spiral Lane Memory	YES	YES	NO	NO	NO
A.2 21	Ramps for Camera	8	9	10	10	10
A.2 23	Power at Start	YES	YES	NO	NO	NO

U.9 06 Install 5 Ball

U.9 07 Install 3 Ball Adjustments U.9 06 and U.9 07 can be used to change a game to 3 or 5 ball play, including the changing of certain features to the recommended 3- and 5-ball level. The Preset Game Adjustments Table for U.S./Canadian Games lists the adjustments and settings that comprise the individual groups.

Preset Game Adjustments Table for U.S./Canadian Games

Adjustment Number	Adjustment Description	Install 5-Ball U.9 06	Install 3 Ball U.9 07
A.1 07	Replay Start	350,000,000	250,000,000
A.2 01	Balls Per Game	3	5
A.2 03	1st Extra Ball Ramps	12	9
A.2 11	1st Hard Lock	2	1
A.2 12	2nd Hard Release	3	2
A.2 13	Last Ramp Release	1	1
A.2 14	Last Easy Release	1	0
A.2 15	Door Spots	1	0
A.2 16	Piano Difficulty	EASY	MEDIUM
A.2 17	Slot Difficulty	EASY	MEDIUM
A.2 18	Spiral Start	EASY	HARD
A.2 19	1st Hard Spiral	1	1
A.2 20	Spiral Lane Memory	NO	NO
A.2 21	Ramps for Camera	10	10
A.2 23	Power at Start	NO	NO

U.9 08 Install Add-A-Ball This option deletes all Free Play awards and replace them with Extra Ball awards. Individual adjustments are affected, as follows:

<u>Adjustment</u>	<u>Name</u>	<u>New Setting</u>
A.1 13	Replay Boost	Off
A.1 14	Replay Award	Extra Ball
A.1 15	Special Award	Extra Ball
A.1 17	Extra Ball Ticket	No
A.1 19	Match Feature	Off
A.4 04	Champion Credits	00
A.4 05	High Score 1 Credits	00
A.4 06	High Score 2 Credits	00
A.4 08	High Score 3 Credits	00
A.4 07	High Score 4 Credits	00

U.9 09 Install Ticket This option deletes Credit awards and replace them with Ticket awards. Individual adjustments are affected, as follows:

<u>Adjustment</u>	<u>Name</u>	<u>New Setting</u>
A.1 14	Replay Award	Ticket
A.1 15	Special Award	Ticket
A.1 16	Match Award	Ticket
A.1 17	Extra Ball Ticket	Yes
A.1 31	Ticket Expansion Board	Yes
A.4 02	H.S.T.D. Award	Ticket

U.9 10 Install Novelty This option removes all Free Play and Extra Ball awards. Individual adjustments are affected, as follows:

<u>Adjustment</u>	<u>Name</u>	<u>New Setting</u>
A.1 04	Max. Extra Ball	Off
A.1 05	Replay System	Fixed
A.1 09	Replay Level 1	Off
A.1 10	Replay Level 2	Off
A.1 11	Replay Level 3	Off
A.1 12	Replay Level 4	Off
A.1 15	Special Award	Points
A.1 19	Match Feature	Off
A.4 01	Highest Score	On
A.4 04	Champion Credits	00
A.4 05	High Score 1 Credits	00
A.4 06	High Score 2 Credits	00
A.4 07	High Score 3 Credits	00
A.4 08	High Score 4 Credits	00

U.9 11 Install Buy-in This option automatically sets game pricing to 1 for 50¢/2 for \$1.00, and 1 Coin Buy-in (A.3 19) to YES. Note that this is not the same feature that allows the player to buy an extra ball at the end of the game. See A.2 01 "Buy Extra Ball".

U.9 12 Serial Capture This sets up the printer adjustments for serial transmission to a laptop computer (9600 baud, 40 column, no page breaks, serial printer). This option requires the installation of the optional printer kit, part number 63110.

U.9 13 Not Used

U.9 14 Not Used

U.9 15 Not Used

U.9 16 Not Used

- U.9 17 Install German 1*
- U.9 18 Install German 2*
- U.9 19 Install German 3*
- U.9 20 Install German 4*
- U.9 21 Install German 5*

U.9 22 Install German 6* Adjustments U.9 17 through U9 22 are used to modify game pricing and type of game play. The Preset Game Adjustments Table for German/European Games lists the adjustments and settings that comprise the individual groups. **NOTE:** German Replay starts at 50,000,000.

Preset Game Adjustments Table for German/European Games

Adj. #	Adj. Description	German 1 U.9 17	German 2 U.9 18	German 3 U.9 19	German 4 U.9 20	German 5 U.9 21	German 6 U.9 22
A.1 14	Replay Award	Credit	Ticket	Audit	Credit	Ticket	Audit
A.1 15	Special Award	Credit	Extra Ball	Points	Credit	Extra Ball	Points
A.1 15	Match Award	Credit	Ticket	Credit	Credit	Ticket	Credit
A.1 19	Match Feature	7%	7%	Off	7%	7%	Off
A.3 01	Game Pricing	6 spiele/5 DM	6 spiele/5 DM	6 spiele/5 DM	7 spiele/5 DM	7 spiele/5 DM	7 spiele/5 DM
A.4 02	H.S.T.D. Award	Credit	Ticket	Credit	Credit	Ticket	Credit
A.4 04	Champion Credits	03	03	00	03	03	00
A.4 05	High Score 1 Credits	01	01	00	01	01	00
A.4 06	High Score 2 Credits	00	00	00	00	00	00
A.4 07	High Score 3 Credits	00	00	00	00	00	00
A.4 08	High Score 4 Credits	00	00	00	00	00	00

• For German Jumpered CPU Boards only. German Jumpers are:

<u>W14</u>	<u>W15</u>	<u>W16</u>	<u>W17</u>	<u>W18</u>
In	In	In	In	Out

- U.9 23 Install French 1*
- U.9 24 Install French 2*
- U.9 25 Install French 3*
- U.9 26 Install French 4*
- U.9 27 Install French 5*

U.9 28 Install French 6* Adjustments U.9 23 through U.9 26 are used to modify game pricing and type of play. The Preset Game Adjustments Table for French Games lists the adjustments and settings that comprise the individual groups.

Preset Game Adjustments Table for French Games

Adj. #	Adjustment Description	French 1 U.9 23	French 2 U.9 24	French 3 U.9 25	French 4 U.9 26	French 5 U.9 27	French 6 U.9 28
A.2 04	Extra Ball Percent	13	12	13	14	10	13

*For French Jumpered CPU Boards only. French Jumpers are:

<u>W14</u>	<u>W15</u>	<u>W16</u>	<u>W17</u>	<u>W18</u>
In	In	In	Out	Out

U.10 Clear Credits Press the Enter button to clear the game Credits.

U.11 Auto Burn-in Press the Enter button to activate Auto Burn-in. This utility automatically cycles through several tests. This will help in find intermittent problems. The tests that Auto Burn-in cycle through are: the Display Test, Sound and Music Test, All Lamps Test, Solenoid Test, Flashers Test, General Illumination Test, and the Flipper Coil Test. All of the tests are run concurrently. The time spent on the current burn-in cycle, and the total time the game has spent in burn-in are displayed.

Press the Enter button to activate the Adjustments Menu, once the menu name is shown under the Main Menu. Press the Up or Down button to cycle through the Adjustment Menu selections. Press the Enter button to activate the selection. Press the Up or Down button to cycle through the available adjustments. Press the Enter button to activate an adjustment. When an adjustment is activated, the setting value begins to flash. Use the Up or Down button to raise or lower the setting value. Press Enter to lock in the value. If a mistake is made, press the Escape button while "Saving Adjustment Value" is displayed. The new value is ignored and the original value is retained. Press the Enter button to return to the Adjustments Menu. Press it again to return to the Main Menu.

A. ADJUSTMENTS MENU

- A.1 Standard Adjustments**
- A.2 Feature Adjustments**
- A.3 Pricing Adjustments**
- A.4 H.S.T.D Adjustments**
- A.5 Printer Adjustments (optional board required)**

A.1 Standard Adjustments

A.1 01 Balls Per Game

A "game" is defined by specifying the number of balls to be played.
Range: 1-10

A.1 02 Tilt Warnings

The number of total actuations of the plumb bob mechanism that can occur before the game is "tilted".
Range: 1-10

A.1 03 Maximum Extra Balls

The number of extra balls that a player may accumulate.
Range: 1-10

A.1 04 Maximum Extra Balls/Ball in Play

The number of extra balls to be awarded per ball in play.

OFF - No maximum number of Extra Balls per ball in play.
1-10 - 1 through 10 Extra Balls per ball in play.

A.1 05 Replay System

The type of replay system to be used.

Fixed - Replay value is set and does not change during game play.
Auto % - Replay starting value is set and changes every 50 games to comply with the percentage of replays desired.

A.1 06 Replay Percent*

The percentage of replays the players are able to earn when Auto Replay is used.
Range: 5-50%

A.1 07 Replay Start*

The replay start value when Auto % Replay is used. The range of this setting is 100,000,000 to 700,000,000.

A.1 08 Replay Levels*

The number of replay levels used by the Auto % Replay mode. The range of this setting is 1 to 4. When two replay levels are chosen, the second replay level is automatically adjusted to twice the starting replay level value. When three of four replay levels are chosen, their values are automatically adjusted to three or four times the starting replay level.

*For Auto % Replay.

A.1 09 Replay Level 1

A.1 10 Replay Level 2

A.1 11 Replay Level 3

A.1 12 Replay Level 4

The values used for the 1st through 4th levels of Fixed Replay. Range: 00 - 25,000,000.

A.1 13 Replay Boost

The replay score can be temporarily boosted by the selected amount EACH time the player reaches or exceeds the replay score. This temporary boost is canceled when credits equal 0, the player inserts another coin, or Begin Test is pressed.

ON - Score is boosted between 1,000,000 and 75,000,000 points.
OFF - Replay score is not boosted.

A.1 14 Replay Award

For the form of award automatically provided when the player exceeds any replay level for either Auto % Replay, or Fixed Replay.

Credit - Reaching each Replay level awards credit.
Ticket - Reaching each Replay level awards a ticket.
Ball - Reaching each Replay level awards an Extra Ball.
Audit - Reaching each Replay level awards nothing to the player; it does increase the entry value of the Audit Item(s) maintaining a tally of these awards.

A.1 15 Special Award

The award automatically provided when the player scores a special.

Credit - Scoring a Special awards a Credit.
Ticket - Scoring a Special awards a Ticket.
Ball - Scoring a Special awards an Extra Ball.
Points - Scoring a Special awards 30 Million points.

A.1 16 Match Award

The award automatically provided when the players wins a match.

Credit - Winning a Match awards a Credit.
Ticket - Winning a Match awards a Ticket.

A.1 17 Extra Ball Ticket

A Ticket is awarded when the player earns an Extra Ball.

YES - The player is awarded a Ticket in addition to an Extra Ball.
NO - The player is not awarded a Ticket.

A.1 18 Maximum Ticket/Player

The amount of Tickets each player can earn.
Range 00 - 100

A.1 19 Match Feature

The desired percentage for the Match Feature occurring at the end of the game.

OFF - Match Feature is not available.

1 -50% - 1% is 'hard'; 50% is 'extremely easy'. The Match Feature selects a random two-digit number at the end of the game and compares each players score for an identical two digits in the rightmost two positions. A matching of these two digits results in an award of a Credit or a Ticket.

A.1 20 Custom Message

The message displayed during the Attract Mode.

YES - A message is displayed

NO - A message is not displayed.

A.1 21 Language

The language the game uses: English, French, or German.

A.1 22 Clock Style

The style of clock the game uses: A.M./P.M., or 24 Hours.

A.1 23 Date Style

The style of date the game uses: Month/Date/Year, or Date/Month/Year.

A.1 24 Show Date and Time

The date and time show in the Attract Mode.

YES - Show date and time in status report, or Attract Mode.

NO - Do Not show date and time in status report or Attract Mode.

A.1 25 Allow Dim Illumination

The game program dims the General Illumination for special effects and during the Attract Mode.

YES - Dim General Illumination for spiral effects and Attract Mode.

NO - Do Not dim General Illumination.

A.1 26 Tournament Play

Equalize Multiball and Jackpots during multi-player games, (do not carry over to next player).

YES - Keep Multiball and Jackpots equal.

NO - Do Not Keep Multiball and Jackpots equal.

A.1 27 Euro. Scr. Format

Use either commas or dots between digits when numbers are displayed.

- YES - Dots instead of commas, (example 1.000.000).
- NO - Commas instead of dots, (example 1,000,000).

A.1 28 Minimum Volume Control

The volume can be turned Off.

- YES - Volume can be turned Off.
- NO - Volume can be turned Down but not Off.

A.1 29 General Illumination Power Saver

This allows the general illumination and controlled lamps to be dimmed following a time interval after a game is played. Power Saver Level (A.1 30) determines how dimness of lamps. Using this feature will substantially increase the life of the lamps.

Setting: - Off, 2-60 Minutes

A.1 30 Power Saver Level

When General Illumination Power Saver (A.1 29) is set to On, this controls the intensity of the G.I. and controlled lamps once the game has been idle for a specified period of time.

Range: 4-7 (4 = dimmest, 7 = brightest)

A.1 31 Ticket Expansion Board

When a Ticket Expansion Board is connected, full control of the ticket dispenser is available. This includes a ticket low/error lamp, resume on ticket jam switch, and manual ticket dispense switch.

- Yes - Ticket Expansion Board is connected.
- No - Ticket Expansion Board is NOT installed in the game.

A.1 32 No Bonus Flips

The activation of flippers during the end of ball "bonus" sequence. Setting this to "YES" may extend the life of the flipper mechanisms.

A.1 33 Game Restart

When the start button is pressed during or after the 2nd ball, the game in progress will end and a new game will begin. This adjustment has 3 settings to determine how this is handled.

Never: - Do not allow a new game to start until the current game is over.

Slow: - Restart if the start button is pressed continuously for over 1/2 second. This helps to prevent the unintended restart of game in progress.

Instantly: - Restart as soon as the start button is pressed.

When the start button is pressed during game over, or during the 1st ball (to add a player), it is always handled instantly.

A.2 Feature Adjustments

A.2 01 Buy Extra Ball

This determines whether each player may buy 1 extra ball for 1 credit at the end of the game.

Settings: 1 CREDIT
OFF

Factory Default: 1 CREDIT

A.2 02 Extra Ball Percent

This determines the total percentage of extra balls desired (for all extra balls awarded from all features except replay score levels). The game will adjust the number of robot ramps required for an extra ball to achieve the requested percentage. Set to "Fixed" to disable the automatic percentaging of the Robot Ramp Extra Ball.

Settings: FIXED
15-40%

Factory Default: 20%

A.2 03 1st Extra Ball Ramps

This is the number of Robot Ramps that will light the 1st Extra Ball. The machine will start with this value and modify it as necessary to achieve the percentage specified in A.2 02. To use a fixed level for the 1st extra ball, set A.2 02 to "fixed", then set this level.

Settings: 3-12

Factory Default: 9

A.2 04 2nd Extra Ball Ramps

This is the number of Robot Ramps that will light the 2nd Extra Ball.

Settings: OFF
30-70

Factory Default: 45

A.2 05 Ramp Extra Ball Memory

This determines whether the Extra Ball that is lit from the Robot Ramp stays in memory from ball to ball.

Settings: YES
NO

Factory Default: YES

A.2 06 Dead Ends for Extra Ball

This is the number of Dead End awards required to light an Extra Ball.

Settings: OFF
2-7

Factory Default: 3

A.2 07 Dead End Extra Ball Memory

This determines whether the Extra Ball that is lit from the Dead End stays in memory from ball to ball.

Settings: YES
NO

Factory Default: NO

A.2 8 Spiral Extra Ball Memory

This determines whether the Extra Ball that is lit from the Spiral stays in memory from ball to ball.

Settings: YES
NO

Factory Default: NO

A.2 9 Door Extra Ball Memory

This determines whether the Extra Ball that is lit from the Door stays in memory from ball to ball.

Settings: YES
NO

Factory Default: YES

A.2 10 1st Hard Lock

This is the number of the 1st multiball round that requires that "Gum-Ball" be spelled twice to lock the balls.

Settings: 1-3

Factory Default: 2

A.2 11 1st Hard Release

This is the number of the 1st multiball round that requires that "Gum-Ball" be spelled an additional time to release the balls for multiball.

Settings: 1-5

Factory Default: 3

A.2 12 Last Ramp Release

This is the number of the last multiball round that will release the balls with a left ramp shot (as well as a shot to the lock). Subsequent rounds will only release by a shot to the lock.

Settings: 0-5

Factory Default: 1

A.2 13 Last Easy Release

This is the number of the last multiball round that will release the balls (from the ramp) after only 1 ball is locked. When Multiball begins after only 1 lock, the jackpot value starts at 10 Million. When Multiball begins after 2 balls are locked, the jackpot value starts at 35 Million. The easy release is not available in rounds higher than the A.2 12 value set for "Last Ramp Release".

Settings: 0-3

Factory Default: 1

A.2 14 Door Spots

This determines the number of door panels that could be spotted by other features. The higher this number is set, the easier it is to complete the door awards to earn "Lost in the Zone".

Set to 0 to disable all spotting.

Set to 1 to spot the 10,000,000 door panel anytime the skill shot upper switch is made for 10,000,000.

Set to 2 to provide the above spot for 10,000,000 and to spot the "Battle the Power" panel when Battle the Power is lit (from the Hitch-Hiker or Spiral).

Set to 3 to provide the above spots and to spot the "Lite GUMBALL" panel when "Lite GUMBALL" is earned from the left and right ramp shots.

Settings: 0-3

Factory Default: 1

A.2 15 Piano Difficulty

This determines the difficulty of lighting the Player Piano for giving door awards.

Settings:	EASY:	piano is lit at beginning of every ball
	MEDIUM:	piano is lit at game start, with memory
	HARD:	piano is NOT lit at game start, with memory
	EXTRA HARD:	piano is NOT lit at game start, no memory

Factory Default: EASY

A.2 16 Slot Difficulty

This determines the difficulty of lighting the Slot Machine for giving door awards.

Settings:	EASY:	slot is lit at beginning of every ball
	MEDIUM:	slot is lit at game start, with memory
	HARD:	slot is NOT lit at game start, with memory
	EXTRA HARD:	slot is NOT lit at game start, no memory

Factory Default: EASY

A.2 17 Spiral Start

This EASY/HARD setting determines whether the game starts with two free spiral lamp awarded.

Settings: EASY
HARD

Factory Default: EASY

A.2 18 1st Hard Spiral

This is the number of the 1st spiral which requires a timed shot. Before this, the spiral shot is lit by the flipper lanes, and stays lit until it is awarded, or until the opposite spiral lamp is lit.

Settings: 1-6

Factory Default: 1

A.2 19 Spiral Lane Memory

This determines whether the "easy " (non-timed) spiral awards (determined by A.2 17) stay in memory from ball to ball.

Settings: YES
NO

Factory Default: NO

A.2 20 Ramps for Camera

This determines the number of robot ramps required to light the Camera. The camera lights for a camera award each time this many robot ramp shots are completed.

Settings: OFF
6-15

Factory Default: 10

A.2 21 Camera Memory

This determines whether camera shots that are lit stay in memory from ball to ball.

Settings: YES
NO

Factory Default: YES

A.2 22 Power at Start

When set to YES, this will make a chance to "Battle the Power" available at the start of each game.

Settings: YES
NO

Factory Default: NO

A.2 23 Outlane Difficulty

This EASY/HARD adjustment determines whether outlanes alternate after they are lit.

Settings: EASY
HARD

Factory Default: HARD

A.2 24 Disable Gumball

In case the gumball machine requires service, this adjustment will stop balls from being shot into the gumball machine. This will allow the game to keep operating until the problem can be repaired.

Settings: YES
NO

Factory Default: NO

A.2 25 Disable Clock

In case the clock requires service, this adjustment will cause the game to simulate all clock functions internally. This will allow the game to keep operating until the problem can be repaired.

Settings: YES
NO

Factory Default: NO

A.2 26 No Powerball

In case there is no white powerball to use in the game, set this adjustment to "YES". The game will simulate the powerball with every 2nd ball delivered from the gumball machine.

This may also be useful in the case of a defective steel ball sensor (there are two, one located by the ball shooter kickout, and one located by the slot machine kicker).

If one of these sensors is defective, you may remove the white powerball from the game (replace it with a steel pinball such that there are still 6 balls in the game), and set this adjustment to "YES".

Settings: YES
NO

Factory Default: NO

A.2 27 Free Ride Time

This determines the time (in seconds) of the free-ride auto-fire feature. This feature will give the player a free ball if the 1st ball in play does not last this length of time.

Settings: OFF
6-15 seconds

Factory Default: OFF

A.2 28 Buy-In Free Time

This determines the time (in seconds) of the free-ride auto-fire AFTER A PLAYER HAS BOUGHT AN EXTRA BALL. This feature will give the player a free ball if the extra ball does not last this length of time.

Settings: OFF
6-30 seconds

Factory Default: 10 seconds

A.2 29 Low Line

If the game is being operated where low line voltage occurs, then this adjustment should be set to "YES". It will disable the upper flippers during POWERBALL MANIA and LOST IN THE ZONE.

Settings: YES
NO

Factory Default: NO

A.2 30 A-Mode Sound

Flipper buttons make a sound in the attract mode.

Settings: YES
NO

Factory Default: YES

A.2 31 A-Mode Music

Music is played periodically in attract mode.

Settings: YES
NO

Factory Default: NO

A.2 32 A-Mode Clock

Clock will show current time in the attract mode.

Settings: YES
NO

Factory Default: YES

A.2 33 Zone Champ Credit

This is the number of credits awarded for the Lost in the Zone champion. The champion is the person who scores the most points during the Lost in the Zone feature.

Settings: 0-3

Factory Default: 1

A.3 Pricing Adjustments

A.3 01 Game Pricing (if set to custom, then 02 to 09 are available)

The cost of a game is selected from the Standard Pricing Table or by installing Custom pricing.

A.3 02 Left Coin Units

A.3 03 Center Coin Units

A.3 04 Right Coin Units

A.3 05 4th Slot Units

The number of coin units purchased by a coin passing through the left, right, center, and fourth coin chutes.

A.3 06 Units/Credits

Defines the number of coin units required to obtain 1 credit. A coin unit counter in the game program totals the number of coin units purchased through all coin chutes prior to each game. If the total number of these coin units exceeds or matches the Unit per Credit value by a multiple (or more, coin units) of the specified Units per Credit value the Credits display shows the proper number of credits. The coin unit counter retains any remaining coin units, until the start of Ball 2; then the coin unit counter is cleared (its contents are zeroed).

A.3 07 Units/Bonus

Additional credits are to be indicated in the credits display, when a certain number of coin units are accumulated.

A.3 08 Bonus Credits

The number of credits that are awarded when the Units/Bonus level is achieved.

A.3 09 Minimum Units

No credits are to be posted (indicated in the credit display), until the credits unit counter reaches a particular value, by setting this value to 02 (or more).

A.3 10 Coin Door Type (if set to custom, then 11 to 15 are available)

This adjustment is used to preset adjustments 11 through 15, based on standard coin doors (U.S.A., German, Etc.).

A.3 11 Collection Text

The coin system used to display the Earning Audits.

A.3 12 Left Slot Value

A.3 13 Center Slot Value

A.3 14 Right Slot Value

A.3 15 4th Slot Value

The monetary value of the left, center, right, and 4th coin chutes.

A.3 16 Maximum Credits

The maximum number of credits the game can accumulate, either through game play awards or coin purchases. The range of this setting is 5 through 99. Reaching the specified setting prevents the award of any credits. The factory default is 10.

A.3 17 Free Play

The player can operate the game without a coin (free play) or with a coin.

- NO - A coin is necessary for game play.
- YES - Game play is free; no coin required.

A.3 18 Hide Coin Audits

The coin audits may, or may not be displayed.

- YES - The coin audits are not displayed.
- NO - The coin audits are displayed.
- HIDE NAMES - The coin audit value is shown but not the audit name.

A.3 19 1 Coin Buy-in

If game pricing is set to 1 for 50¢/2 for \$1.00 the player is allowed to 'buy-in' a subsequent game for 1 coin. The number of games that may be purchased at this cost is determined by the number of players in the previous game; that is, if the previous game had three players, 3 Credits can be purchased at the rate of 1 coin per credit. Note that this is not the same feature that allows the player to buy an extra ball at the end of the game. See A.2 01 "Buy Extra Ball".

- YES - The player has 10 seconds to buy-in at 1 coin per game.
- NO - The buy-in feature is disabled.

A.3 20 Base Coin Size

The number of ticket per coin calculations.

A.3 21 Coin Meter Units

It is possible to connect a coin meter to the knocker coil driver which will log all coins through all slots. This adjustment activates the use of the knocker driver for this purpose, and determines the value of each unit on the meter. For example, to show the total amount of money collected as "total quarters", set this adjustment to "0.25". To show the amount of money collected as "total dollars", set this adjustment to "1.00".

Setting this adjustment to anything other than Off establishes the coin unit for a meter attached to the knocker driver, and overrides use of the knocker during awards.

A.3 22 Dollar Bill Slot

The system normally requires 150 microseconds between coin pulses. This is too long a delay for a fast-pulsing dollar bill validator. This adjustment may be used to tell the game that there is a fast pulsing dollar bill validator connected to one of the coin switches. The options are:

- NONE = No validator connected.
- LEFT = Validator connected to left slot.
- CENTER = Validator connected to center slot.
- RIGHT = Validator connected to right slot.
- FOURTH = Validator connected to fourth slot.

A.3 23 Minimum Coin Microseconds

This is the minimum width required for coin pulses to be accepted as valid coins. This may be changed to prevent certain kinds of cheating.

Pricing Table

Country	Coin Chutes				Games/Coins	Display	Pricing Adjustments A3											
	Left Chute	Center	4th Right				02	03	04	05	06	07	08	09				
USA	25¢	\$1.00*	25¢	-	1/50¢, 2/75¢, 3/\$1 ² 1/50¢, 2/\$1 ² 1/25¢, 3/\$1 ² 1/50, 2/\$1.00, 6/\$2.00 1/50, 2/\$1.00, 5/\$2.00 1/50, 2/\$1.00, 4/\$1.50, 6/\$2.00 ^{1,2}	50¢, 75¢, \$1.00 USA 2/\$1.00 USA 3/\$1.00 USA 6/\$2.00 USA 5/\$2.00 6/\$2.00 4/\$1.50												
Canada	25¢	-	\$1.00	-	1/50¢, 2/75¢, 3/\$1 1/50¢, 2/\$1 ²	CANADA 1 CANADA 2												
Austria	5sch 5sch	10sch -	10sch 10sch	-	1/2x5sch, 3/2x10sch ² 2/5sch, 5/10sch	AUSTRIA CUSTOM	02	00	05	00	01	00	01	00				
Australia	20¢	\$1	\$1	\$2	1/\$1, 3/\$2 ²	AUSTRALIA												
U.K.	£1.00	50P	20P	10P	1/3x10P, 2/50P, 4/£1 ²	U. KINGDOM												
Switzerland	1Fr 1Fr	2Fr 2Fr	5Fr 5Fr	-	1/1Fr, 3/2Fr, 7/5Fr ² 1/2Fr, 2/3Fr, 3/4Fr, 5/5Fr	SWISS SWISS 2												
Belgium	5Fr	20Fr	50Fr	-	1/4x5Fr, 1/20Fr, 3/50Fr ²	BELGIUM												
Germany	1DM	2DM	5DM	-	1/2DM, 2/3DM, 3/4DM, 5/5DM ^{1,2}	GER. 1/2DM												
Holland	1G	-	1G	-	1/1G	HOLLAND												
Sweden	1Kr 5Kr	5Kr 5kr	10Kr 5Kr	-	1/5x1Kr, 1/5kr, 2/10Kr ^{1,2} 1/5Kr ²	SWEDEN 1 SWEDEN 2												
France	1Fr 1Fr 1Fr 1Fr 1Fr 1Fr 1Fr	5Fr 5Fr 5Fr 5Fr 5Fr 5Fr 5Fr	10Fr 10Fr 10Fr 10Fr 10Fr 10Fr 10Fr	20Fr 20Fr 20Fr 20Fr 20Fr 20Fr 20Fr	1/3x1Fr, 2/5Fr, 5/10Fr, 10/20Fr ^{2,3} 1/2x1Fr, 3/5Fr, 7/10Fr, 14/20Fr ^{2,3} 1/5Fr, 3/10Fr, 7/2x10Fr, 7/20Fr ^{1,2,3} 2/5Fr, 4/10Fr, 9/2x10Fr, 9/20Fr ^{2,3} 2/5Fr, 5/10Fr, 11/2x10Fr, 11/20Fr ^{2,3} 1/5Fr, 3/10Fr, 6/20Fr ^{2,3}	TARIF 1 TARIF 2 TARIF 3 TARIF 4 TARIF 5 TARIF 6												
Italy	500L 500L	- -	500L 500L	-	1/500L ² 1/2x500L, 3/4x500L ^{1,2}	ITALY 1 ITALY 2												
Spain	100P 25P 25P 25P 25P	- - - - -	500P 100P 100P 100P 100P	- - - - -	1/100P, 6/500P ² 1/25P, 5/100P 1/25P, 4/100P 1/2x25P, 2/100P 1/2x25P, 3/100P	SPAIN CUSTOM CUSTOM CUSTOM CUSTOM	01	00	04	00	01	04	01	00				
Japan	100¥	-	100¥	-	1/100¥ ²	JAPAN												
Chile	Token	-	Token	-	1/1Token ²	CHILE												
Denmark	1Kr	5Kr	10Kr	-	1/2x1 Kr, 3/5Kr, 7/10Kr ²	DENMARK												
Finland	1Mka	-	5Mka	-	1/2x1Mka, 3/5Mka ²	FINLAND												
New Zealand	\$1.00	-	\$2.00	-	1/\$1, 3/\$2	NEW ZEALAND												
Norway	5Kr	-	10Kr	-	1/5Kr, 2/10Kr, 5/20Kr ²	NORWAY												
Argentina	10¢	10¢	10¢	-	1/1 Token ²	ARGENTINA												
Hungary	10F	10F	20F	-	1/1x20F, 1/2x10F, 3/2x20F ²	HUNGARY												

Note: 1. Factory Default. 2. Standard Setting - Change by pressing Enter button. 3. Other functions are also affected.
* Only if Bill Acceptor and Center Coin Chute are available.

A.4 H.S.T.D. Adjustments

A.4 01 Highest Scores

The game maintains a record of the four highest scores achieved to date.

- OFF - No high scores are recorded, or displayed.
- ON - The four highest scores are stored in memory and displayed in the Attract Mode.

A.4 02 H.S.T.D. Award

The award given for achieving the High Score To Date, or the Champion H.S.T.D: Credit or Ticket.

A.4 03 Champion H.S.T.D.

The "Highest" High Score is displayed in the Attract Mode. This score is not cleared when "High Score Reset Every" occurs.

- ON - The "Highest" High Score is retained in memory and is displayed.
- OFF - The "Highest" High Score is not retained.

A.4 04 Champion Credits

The operator chooses the number of credits or tickets awarded for a Grand Champion Score. Range: 00 - 10.

A.4 05 H.S.T.D. 1 Credits

A.4 06 H.S.T.D. 2 Credits

A.4 07 H.S.T.D. 3 Credits

A.4 08 H.S.T.D. 4 Credits

The number of credits or tickets to be awarded whenever a player exceeds the 1st, 2nd, 3rd, and 4th highest scores. Range: 00 - 10.

A.4 09 High Score Reset Every

The number of games to be played before an automatic reset of the displayed "Highest Score" occurs. The values provided upon reset are those selected by the operator in the Back-up High Scores. Range: OFF (disabled); 250 to 20, 000.

A.4 10 Backup Champion

The Back-up Grand Champion Score. Range: 00 - 99,900,000.

A.4 11 Backup H.S.T.D. 1

A.4 12 Backup H.S.T.D. 2

A.4 13 Backup H.S.T.D. 3

A.4 14 Backup H.S.T.D. 4

The first through the fourth Back-up High Score values. The game automatically restores this value when the High Score Reset Every value is reached. Range: 00 - 99,900,000.

A.5 Printer Adjustments (optional board required)

A.5 01 Column Width

The column width to be printed. Range: 22 - 80.

A.5 02 Lines Per Page

The amount of lines per page. Range: 20 - 80.

A.5 03 Pause Every Page

Choose whether the printer pauses at the end of a page.

- YES - The printer does pause.
- NO - The printer does not pause.

A.5 04 Printer Type

Select the type of printer . Choices: Parallel, Serial, ADP., Mini-Drucker, or NSM.

A.5 05 Serial Baud Rate

The baud rate used for Serial or ADP communications (bit rate). Choices: 300, 600, 1200, 2400, 4800, or 9600.

A.5 06 Serial D.T.R. (Data Terminal Ready)

When a Serial Printer is used, this line may be connected to a printer output line signaling that the printer is busy.

- Normal - Normal D.T.R. signal goes low to indicate the printer is not ready.
- Inverted - Inverted D.T.R. (busy) signal goes high to indicate printer is not ready.
- Ignore - D.T.R. signal is ignored.

ERROR MESSAGES

The WPC game program has the capability to aid the operator and service personnel. At Game Turn-on, or after pressing the Begin Test switch, (once the game has been operating for an extended period), the display may signal with the message, "Press ENTER for Test Report". This indicates the game program has detected a possible problem with the game.

To obtain details of the problem, open the coin door and press the Begin Test switch. Press the Enter button to begin displaying the message(s). The following messages apply to your game.

Check Switch ##.

This message indicates that at least one switch was stuck 'On' at game turn-on or has NOT been actuated during ball play (for 90 balls or ≈30 games). The game program compensates the game play requirements affected by each disabled switch to allow 'nearly normal' play. This helps keep the game earning, until the service technician can repair the problem.

To verify the problem, refer to the Test Menu text describing Switch Testing, and check each reported switch using applicable switch tests. Always check switch operation using a ball, to simulate game conditions. Switch problems may often be resolved by adjusting the wire switch actuators, fixing switch circuitry problems, securing loose connectors, etc. Mechanisms using 'opto switches' (drop targets, etc.) need to be checked for proper power connections (+12V dc and ground).

Pinball Missing.

This game normally uses six balls; however, it will operate with as few as one ball. This message announces that a ball is missing or stuck. When the ball is located, return it to the game via the Outhole. Other possibilities for this problem could be malfunctions of the Ball Trough switches or the Ball Shooter switch.

xxxxx Sw. is Stuck On.

This message indicates that a switch, which is not usually On, remains in the On position after the game is switched On. The stuck switch is essential for game play (for example, a coin chute switch, the slam tilt switch, the plumb bob tilt switch), and should be cleared to permit proper game operation.

Ground Short Row-N, Wht-xxx.

This message indicates that the switch wires being called out are touching a grounded part on the playfield or coin door. The following should be checked:

1. Slam Tilt (or other coin door) switch touching the grounded coin door.
2. A leaf-type, playfield switch touching a grounded part.
3. Players poking metallic objects (wires, coat hanger, etc.) into the game
4. Switch cable insulation pierced or damaged allowing bare wire contact with a grounded part
5. All switches in a row closing at the same time. Note: This instance is NOT a switch problem; however, for most games this is a very rare possibility.

U6 Checksum Error.

The game ROM checksum is invalid. If this occurs replace the game ROM.

Time and Date Not Set.

The real time clock is not running. If this occurs go to U.4 of the Utilities Menu and set the time and date.

Factory Settings Restored.

This message indicates that the CMOS RAM no longer retains any custom Pricing or Game Adjustment settings and has reverted to factory default settings. Generally, the following CPU checks will isolate the cause of the CMOS RAM memory failure. The voltage at pin 28 and pin 26 of U8 should be +5V (game turned On) and at least +4V (game turned Off). When the voltage drops below +4 V, memory reset occurs. Check the batteries and battery holder. Be sure that the batteries are good and that there is no contamination on the battery holder terminals. Turn the game OFF, and use an ohmmeter to check diodes D1 and D2 on the CPU Board. D1 should read 0 ohms when forward-biased and infinite ohms when reverse-biased. D2 should read 15 ohms when forward-biased and infinite ohms when reverse-biased. Note: Readings taken from Analog Meter. This message can also indicate that there is an open diode on a 50V coil, and noise is entering the circuit.

CPU L.E.D.'s

The CPU has three L.E.D.'s located on the upper left side of the board: D19, D20, and D21. On game power-up D19 and D21 turn On for a moment then, D19 turns Off and D20 starts to blink rapidly. D21 remains On. The system has detected a problem if the following happens:

CPU Board L.E.D. Error Codes

Center L.E.D. blinks one time	-	ROM Error U6
Center L.E.D. blinks two times	-	RAM Error U8
Center L.E.D. blinks three times	-	Custom Chip Failure U9

Sound Board Beep Error Codes

Upon Game Turn-On:

1 Beep	=	Sound Board O.K.
2 Beeps	=	U9 Failure (RAM)
3 Beeps	=	U18 Failure (ROM)
4 Beeps	=	U15 Failure (ROM), if used
5 Beeps	=	U14 Failure (ROM), if used

OPTO THEORY

The opto receiver (detector) should be approximately 0.1-0.7 volts when the opto beam is unblocked and approximately 11-13 volts when the opto beam is blocked. The opto transmitter (emitter or L.E.D.) should always be approximately 1.4 volts. Note, the transmitter (L.E.D.) is larger than the receiver (it protrudes further from its case).

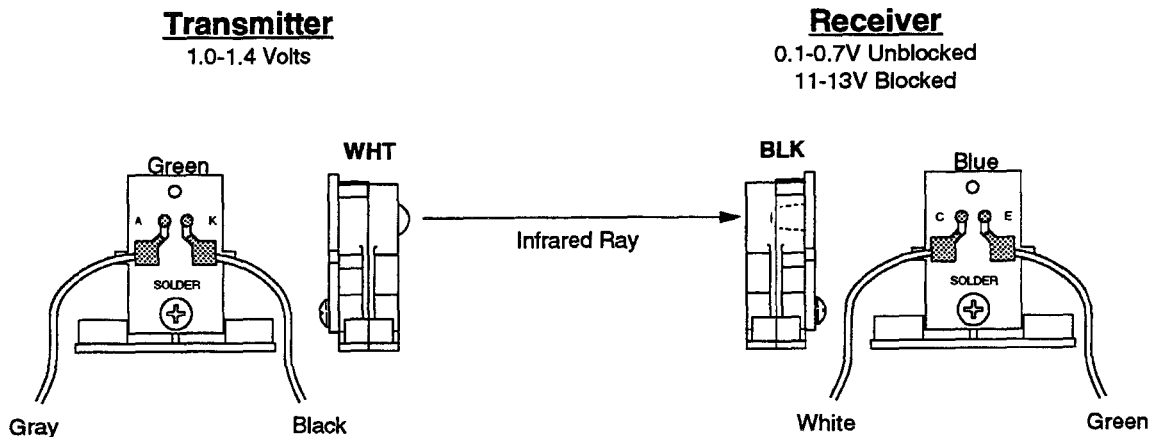

LED List

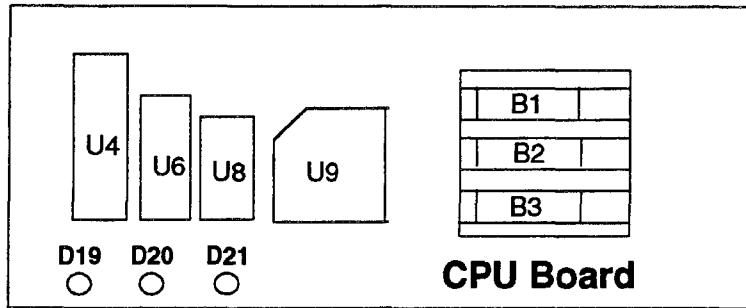

CPU Board

D19, Blanking

D20, Diagnostic

D21, +5vdc

At Game Turn-On = D19 & D21 On, D20 Off

During Normal Operation = D19 Off, D20 flashing, D21 On

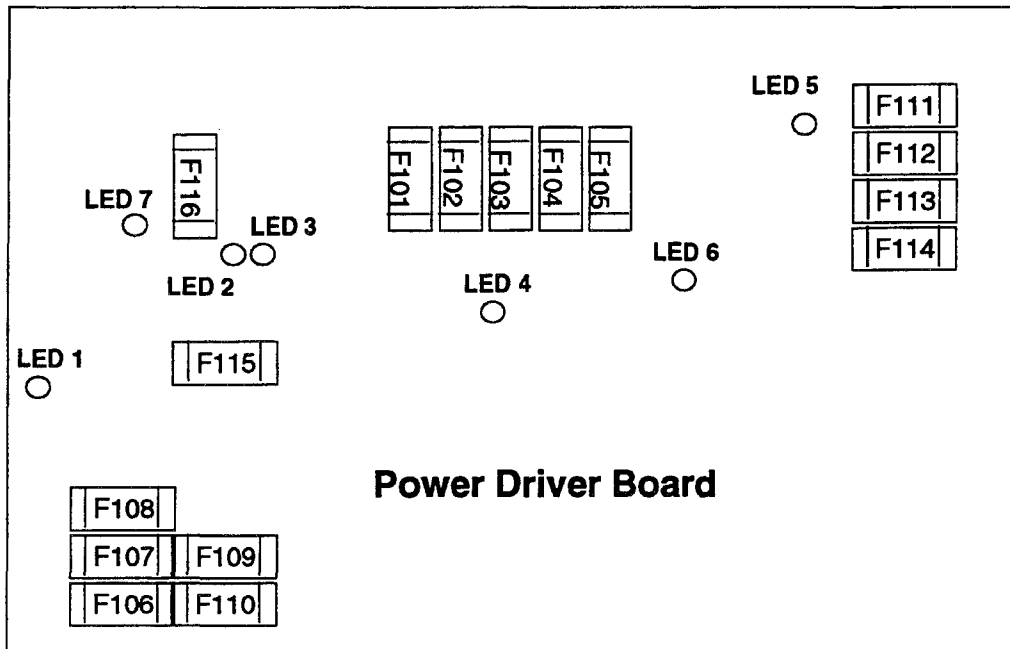

Power Driver Board

LED 1, +12vdc, Switch Circuit, Normally On

LED 2, High/Low Line Voltage Sensor, Normally On

LED 3, High/Low Line Voltage Sensor, Normally Off

LED 4, +5vdc, Digital Circuit, Normally On

LED 5, +20vdc, Flashlamp Circuit, Normally On

LED 6, +18vdc, Lamps Circuit, Normally On

LED 7, +12vdc, Power Circuit (Motors, Relays, Etc.), Normally On

Fuse List

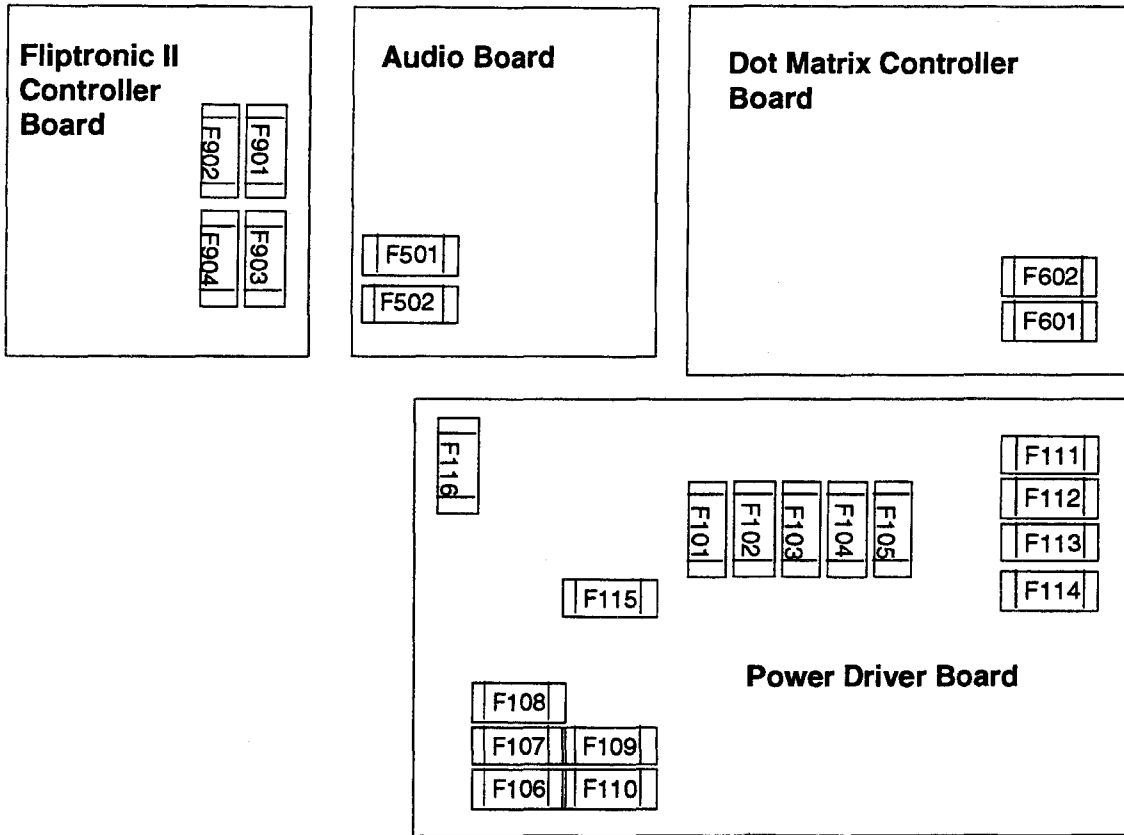

Audio Board

F501 -25V Circuit 3A, S.B.
 F502 +25V Circuit 3A, S.B.

Dot Matrix Controller Board

F601 +62V Circuit 3/8A, S.B.
 F602 -113V and -125V Circuits 3/8A, S.B.

Power Driver Board

F101 Left Flipper 3A, S.B. (Not Used)
 F102 Right Flipper 3A, S.B. (Not Used)
 F103 Solenoid #25-#28 3A, S.B.
 F104 Solenoid #9-#16 3A, S.B.
 F105 Solenoid #1-#8 3A, S.B.
 F106 G.I. #5 Wht-Vio 5A, S.B.
 F107 G.I. #4 Wht-Grn 5A, S.B.
 F108 G.I. #3 Wht-Yel 5A, S.B.
 F109 G.I. #2 Wht-Org 5A, S.B.
 F110 G.I. #1 Wht-Brn 5A, S.B.
 F111 Flasher Secondary 5A, S.B.
 F112 Solenoid Secondary 7A, S.B.
 F113 +5V Logic 5A, S.B.
 F114 +18V Lamp Matrix 8A, N.B.
 F115 +12V Switch Matrix 3/4A, S.B.
 F116 +12V Secondary 3A, S.B.

Fliptronic II Controller Board

F901 Upper Left Flipper 3A, S.B.
 F902 Upper Right Flipper 3A, S.B.
 F903 Lower Left Flipper 3A, S.B.
 F904 Lower Right Flipper 3A, S.B.

Line Filter

Domestic Game 8A
 Foreign Game 5A, S.B.

MAINTENANCE INFORMATION

LUBRICATION

The two main lubrication points of the Ball Shooter Lane Feeder mechanism are the pivots for the arm. The mechanism of other playfield devices are somewhat similar and have the same lubrication requirements. A medium viscosity oil (switch target grease) is satisfactory for these devices.

Because of the functional design (arm-actuated via solenoid plunger operation), the pivot points of the Left and Right Kickers ("Slingshots") all require lubrication as a regular servicing procedure.

Lubrication to ensure proper operation also applies to the target blades of Drop Targets. MBI Instrument Grease, also known as Drop Target Switch Lubricant, (Bally part number of EI 165), is a recommended lubricant.

SWITCH CONTACTS

Playfield Switches

For proper game operation, switch contacts should be free of dust, dirt, contamination, and corrosion. Blade switch contacts are plated to resist corrosion. Cleaning blade switch contacts requires gentle closing of the contacts on a clean business card or piece of paper, and then pulling the paper about 2 inches, which should restore the clean contact surface. Adjust the switch contacts to a 1/16-inch gap.

Flipper Switches

This game uses the new Fliptronic II Electronic Flipper System. The end-of-stroke switches are NORMALLY OPEN and should close when the flipper is energized. All end-of-stroke switches and flipper button cabinet switches are gold flashed computer grade leaf switches. Only low computer current is carried through these switches. DO NOT FILE or abrasively clean these switches! DO NOT REPLACE these switches with the old style tungsten high current type switches, as intermittent operation could occur. Please note that unlike the old style of flipper, an end-of-stroke switch failure will not harm the flipper. The game will notify the operator of a switch being mis-adjusted in the test report, but will continue to play. The end-of-stroke switches are a means by which the new electronic flippers feel and play with all of the subtleties of the old flippers.

CLEANING

Good game action and extended playfield life are the results of regular playfield cleaning. During each collection stop, the playfield glass should be removed and thoroughly cleaned and the playfield should be wiped off with a clean, lint-free cloth. The game balls should be cleaned and inspected for any chips, nicks, or pits. Replace any damaged balls to prevent playfield damage.

Regular, more extensive, playfield cleaning is recommended. However, avoid excessive use of water and caustic or abrasive cleaners because they tend to damage the playfield surface. Playfield wax (or any carnauba based wax), or polish may be used sparingly, to prevent a buildup on the playfield surface. Do not use cleaners containing petroleum distillates on any playfield plastics because they may dissolve the plastic material or damage the artwork.

TWILIGHT ZONE

UNIT DISASSEMBLY for REPAIR

Major component removal and replacement

TABLE OF CONTENTS

CLOCK.....	1-50
CLOCK GEAR TRAIN.....	1-51
MAIN RIGHT STEEL RAMP	1-52, 53
MAIN RIGHT STEEL RAMP CHUTE	1-52, 53
GUMBALL MACHINE.....	1-54, 55
GUMBALL WIRE ENTRY CHUTE.....	1-54, 55
MAIN LEFT PLASTIC RAMP ASSEMBLY.....	1-56, 57
MINI-PLAYFIELD (POWERFIELD).....	1-58
OPTICAL 3 BALL LOCK ASSEMBLY	1-59

CLOCK REMOVAL AND REPLACEMENT

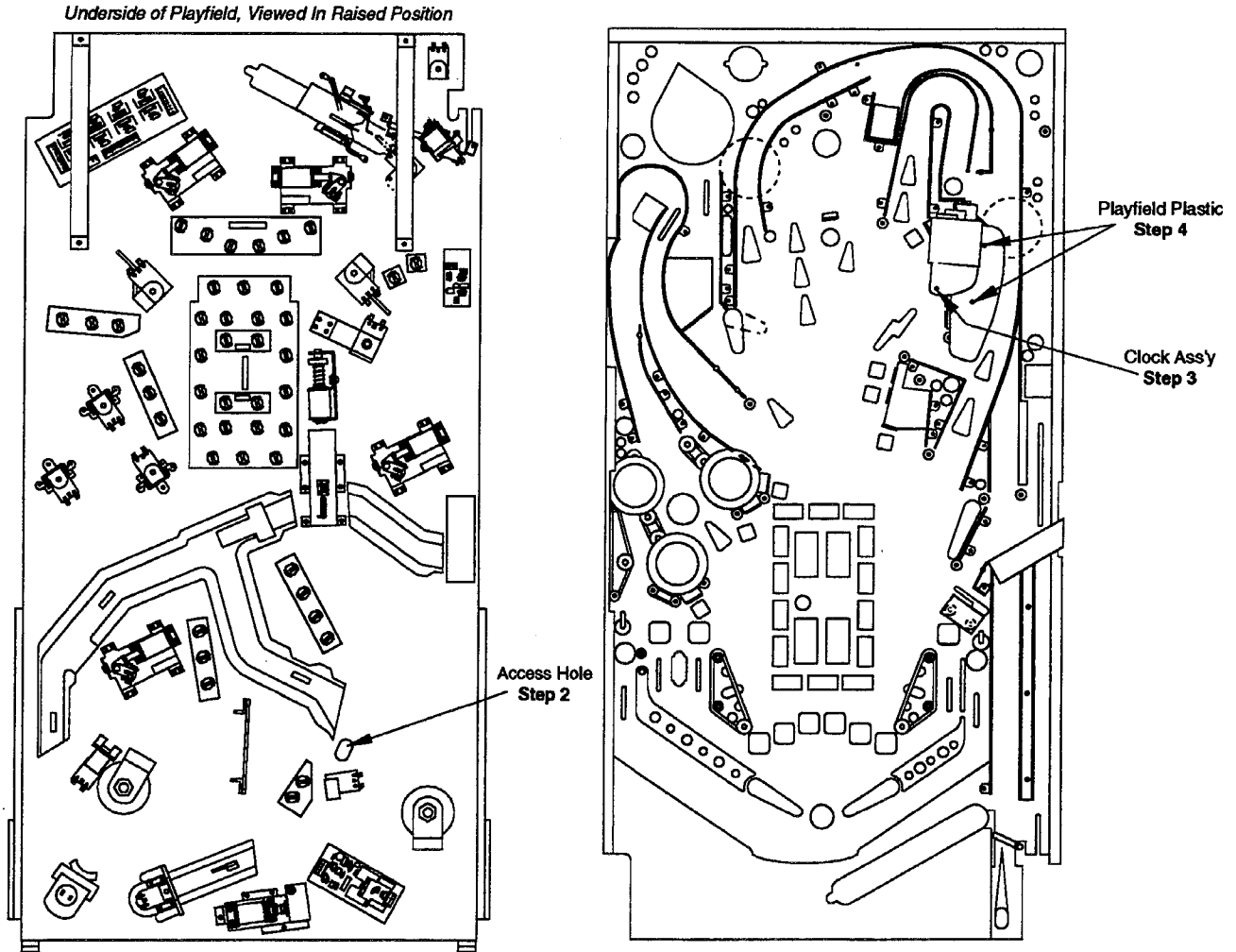

1. Turn power switch OFF.
2. Raise the playfield and disconnect the 3 connectors that make up the wiring harness for the clock.
3. Lower the playfield. Remove the phillips screw located on the front base of the clock. Carefully slide the clock backwards about 1/2 inch. The clock should now be free.
4. Lay the clock on the playfield and remove the 2 nuts that hold the playfield plastic down in the area of the clock. Remove the plastic.
5. Pull the clock harness through the playfield to complete removal.
6. Replacement is the reverse of removal. Be careful during replacement that the locking tab on the base of the clock slides into and under the notch of the roof of the player piano scoop.

CLOCK GEAR TRAIN ASSEMBLY

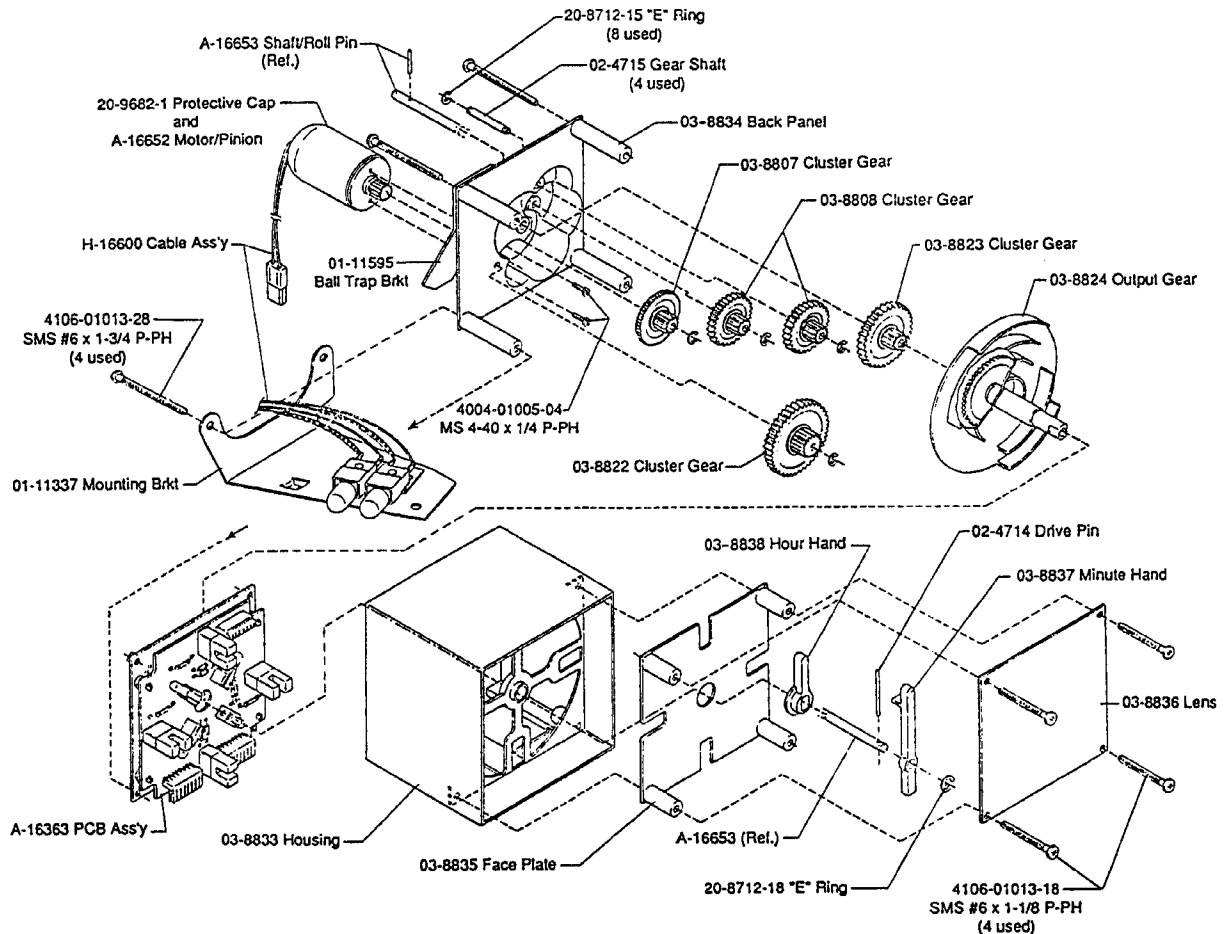

1. Install motor & pinion assembly (A-16652) to back panel (03-8834).
2. Install fine tooth cluster gear (03-8807) on shaft (02-4715) nearest the motor.
3. Install two (03-8808) cluster gears, large diameter first, on next two shafts (02-4715).
4. Install cluster gear (03-8823) on shaft & roll pin assembly (A-16653) with slot on back side of gear firmly engaged with roll pin.
5. Insert stub end of shaft into center hole of back panel, while aligning either of the two opposite, shorter teeth on smaller diameter gear of 03-8823 with remaining shaft.
NOTE: If proper alignment is not achieved in Step 5, rotate entire gear train by turning the fine tooth gear (03-8807) until such alignment is attained.
6. Install gear (03-8822) on remaining shaft with the two adjacent shorter teeth of the small diameter gear straddling a shorter tooth of gear 03-8823.
7. Install e-rings (20-8712-15) on all four shafts to retain gears in position before proceeding.
8. Install large, black gear (03-8824) on center shaft, such that its indicated tooth (molded line) is straddled by the two adjacent shorter teeth on the small diameter gear of 03-8822.
9. Install entire assembly (Steps 1-8) along with Clock P.C. Board Assembly into the housing (03-8833) with motor on same side as cable opening.

MAIN RIGHT STEEL RAMP AND MAIN RIGHT STEEL RAMP CHUTE REMOVAL AND REPLACEMENT

1. Turn power switch OFF.
2. Raise the playfield. There is an access hole through which both the clock and ramp wiring extends. Unplug the connector for the ramp optical switches.
3. Lower the playfield. Leave playfield in its most forward position for easier access to ramp screws.
4. Remove the phillips screw that holds the clock base to the piano scoop roof. Gently push back on the clock and slide it about 1/2 inch backward. Lift up and the clock should be free.
5. Lay the clock on the playfield and remove the 2 nuts that hold the playfield plastic down in the area of the clock. Remove the plastic.
6. Remove the phillips screw which holds the playfield plastic that is directly under the metal ramp. Remove the plastic.
7. There should now be access to pull the optical switch harness for the ramp through the playfield. Pull the harness through.
8. Remove the two #1 phillips screws that hold the ramp entry into the wood. Note that the screws DO NOT hold down the flap. They are designed to hold the steel ramp in place. The flap should be free and have a gentle arc from playfield to ramp.
9. There is a leg on the right side of the ramp. Remove the screw that holds this leg to the top of the 3 ball lock mechanism. On EARLY production units there is a 1/4 inch plastic spacer between the leg and the lock roof. DO NOT LOOSE THE SPACER! Without the spacer there is insufficient pitch (right to left) for the ball to roll towards the mini-power playfield.
10. Remove the screw that holds the wire chute to the left main ramp left entry post.
11. Carefully remove the E-ring that holds the diverter scoop to its pivot on the wire chute. Remove the pivot pin. Tip the diverter scoop to remove it from the pull wire.
12. Remove the screw that holds the wire chute to the mini-playfield. It is located between the rails of the chute at the mini-playfield entrance.
13. Remove the metal ramp and chute.
14. Note that the chute has a hook which locks into a hole located in the top of the metal ramp. Unhook the chute from the ramp and slide them apart.
15. Replacement is the reverse of removal, being careful that the chute hook must go into the mating hole on the ramp. Also be careful to replace the spacer (if necessary) in its proper location. Care must also be taken NOT to catch the flap at the ramp entry under the screws.

NOTE!!! EARLY GAMES HAD 3 WASHERS UNDER THE WIRE CHUTE ATTACHING LEG. THESE ARE NOT NECESSARY ON REPLACEMENT WIRE FORMS!!! DO NOT RE-INSTALL THESE 3 WASHERS AS THE LEG WAS MADE LONGER!!!

Underside of Playfield, Viewed In Raised Position

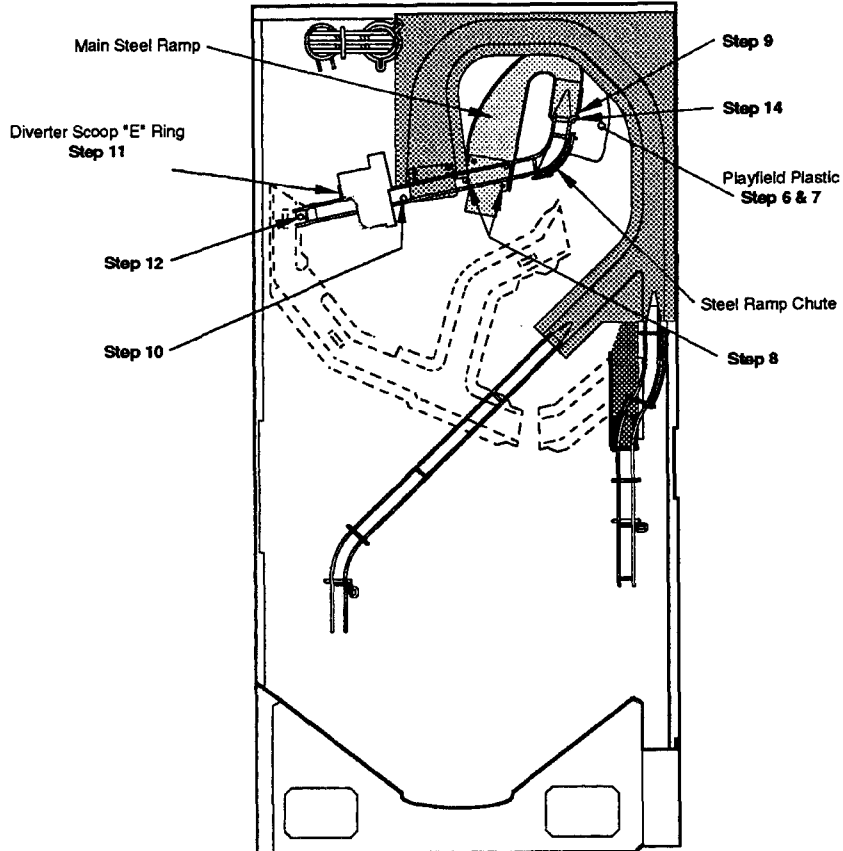
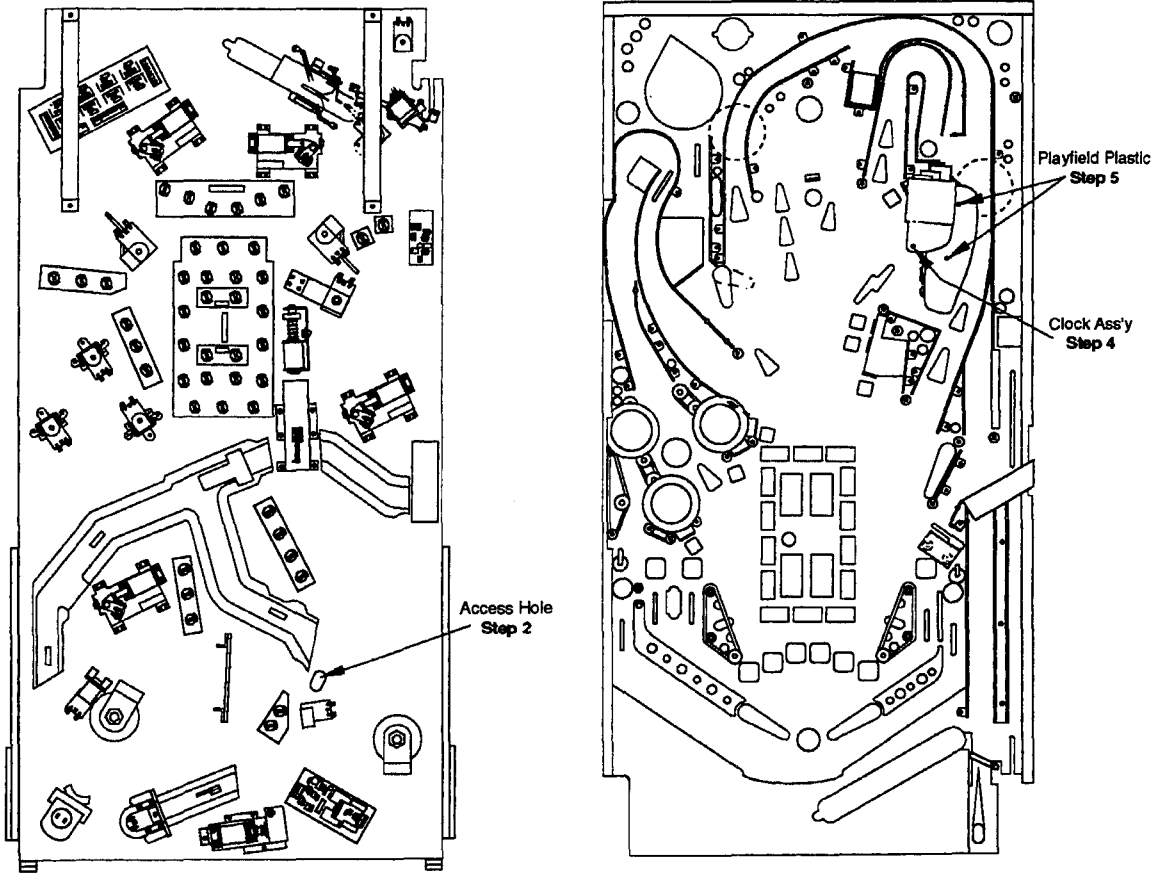

GUMBALL MACHINE AND GUMBALL WIRE ENTRY CHUTE REMOVAL AND REPLACEMENT

1. Turn power switch OFF.
2. Raise the playfield. On the left rear there are 2 small wiring harnesses connected to the gumball mechanism. Unplug them.
3. On the left rear there are 2 harnesses attaching the rear flasher lamp stack and the optical switches for the gumball entry wire chute. Unplug them.
4. Lower the playfield. Leave playfield in its most forward position for easier access to gumball machine area.
5. Remove the top flash lamp cover and bulb from the flash stack.
6. Gently work your hands under the left side of the flash stack and begin to lift. By rotating the stack it is possible to remove it without removing the playfield from cabinet.
7. Remove the 3 nuts holding the playfield plastic to the right of the gumball machine. Remove the plastic.
8. Remove the 4 screws securing the gumball machine to the playfield.
9. The gumball machine may now be removed from the playfield.

To remove the gumball wire entry chute the following steps are necessary.

10. Remove the 2 #1 phillips screws that attach the entry of the left main plastic ramp. Remove the phillips screw that attaches the ramp to the first post after entry on the right side (about 5 inches up the ramp).
11. The left upper ramp corner may now be lifted enough so that access is gained to the playfield plastic to the right of the wire chute. Remove the left nut on this plastic. Pick up the plastic and rotate it counter-clockwise on the remaining screw about 1 inch.
12. Access has been gained to the sheet metal screw holding the chute in place. Remove this screw using a long reach magnetic tip screwdriver.
13. Pull up to remove the wire chute.
14. Reassemble in the reverse order.

Underside of Playfield, Viewed In Raised Position

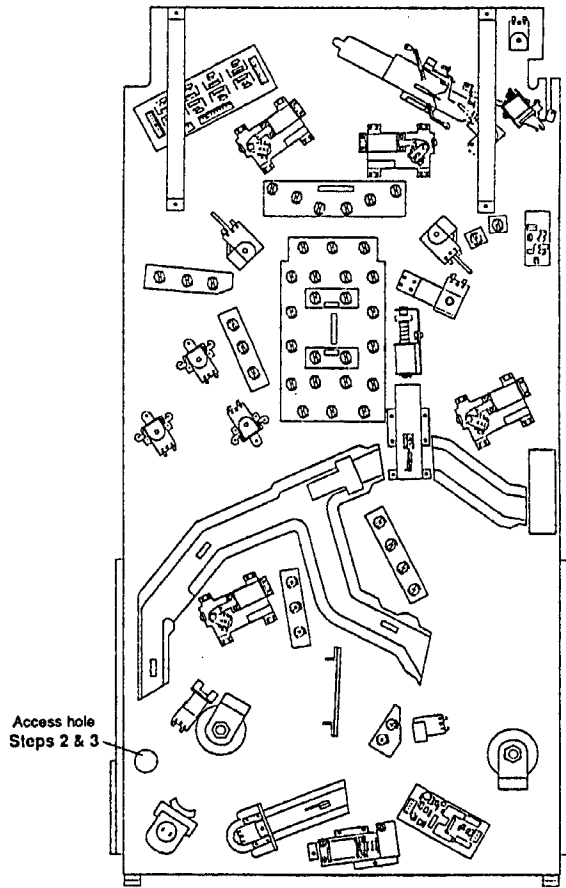

Lamp Cover (clear) & Bulb
Step 5

Gumball Machine
Step 8

Playfield Plastic
Step 7

Flash Stack
Step 6

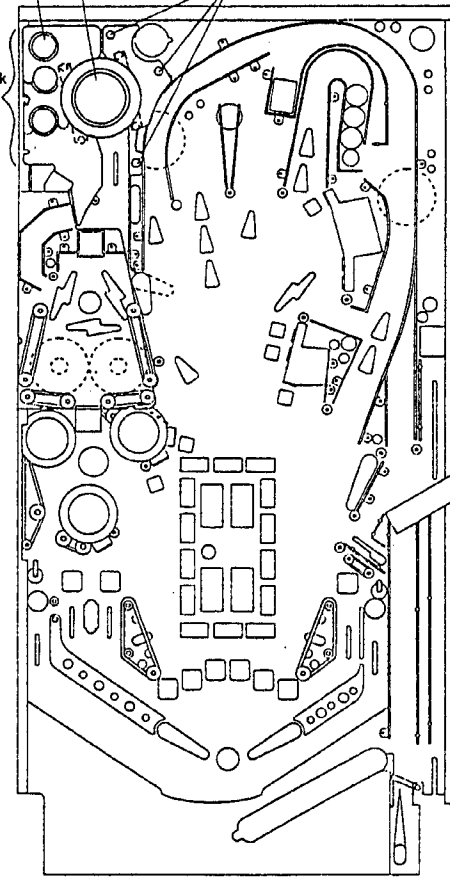

Playfield Plastic
Step 11

Step 12

Wire Entry Chute

Step 10 (Part 2)

Step 10 (Part 1)

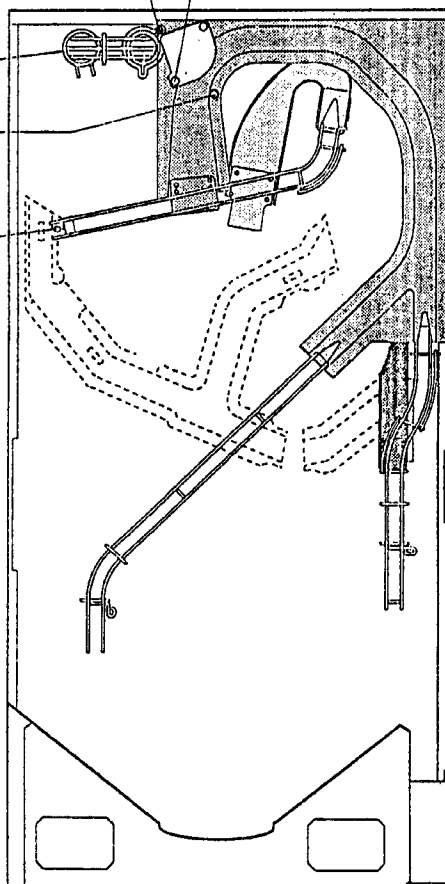

MAIN LEFT PLASTIC RAMP ASSEMBLY REMOVAL AND REPLACEMENT

1. Turn power switch OFF.
2. Raise the playfield. In the far right rear corner of the playfield there is an access hole for the ramp wiring. Unplug the 3 ramp connectors. In the middle of the playfield between the two ramps there is an access hole which contains 1 switch connector. Unplug this connector.
3. Lower the playfield. Leave playfield in its most forward position for easier access to ramp screws.
4. Remove the 2 small #1 phillips screws which hold the ramp entry to the wood.
5. Remove the 2 screws that hold the ramp to its mounting posts.
6. Remove the 2 screws that hold the ramp to the ramp diverter assembly.
7. Remove the 4 screws that hold the ramp to the two wire chutes.
8. Gently lift up on the ramp to gain access to the right rear playfield plastic. Loosen but DO NOT REMOVE the 3 screws that hold the plastic to the wood rail. Remove the plastic.
9. The ramp should now be free to remove from the game.
10. Replacement is the reverse of removal.

Underside of Playfield, Viewed In Raised Position

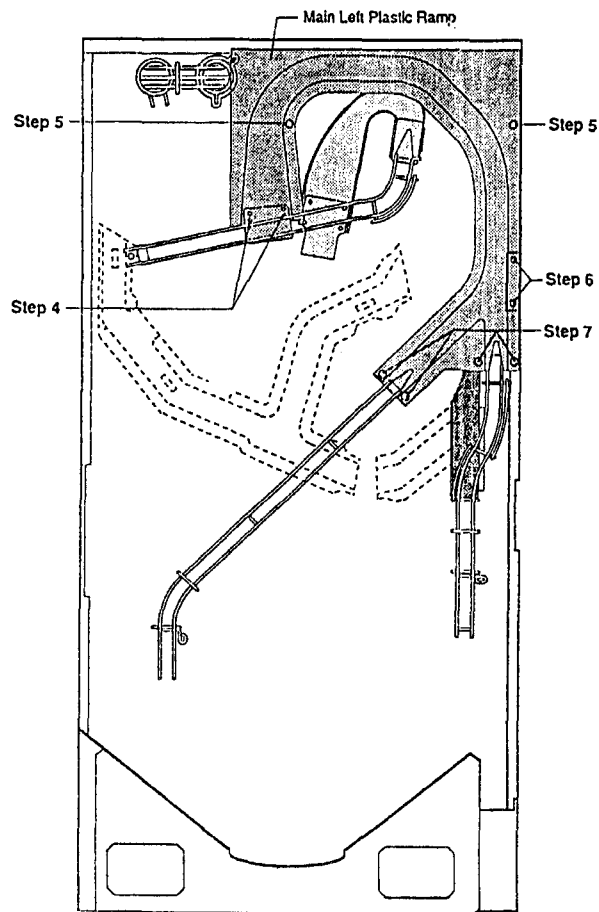
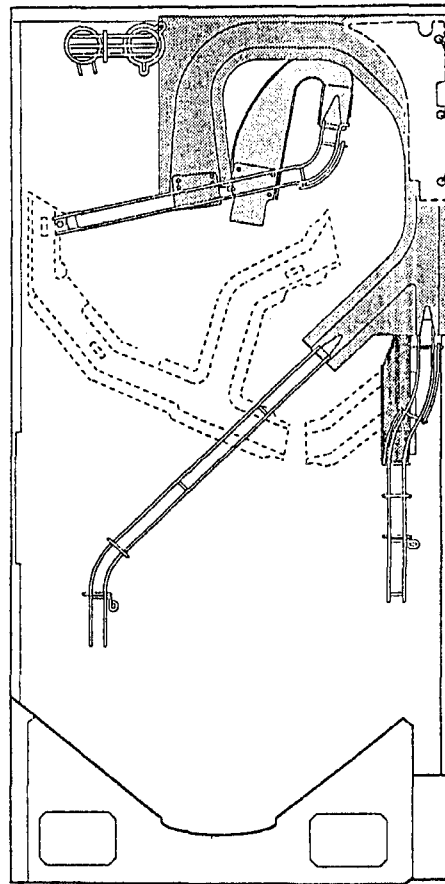
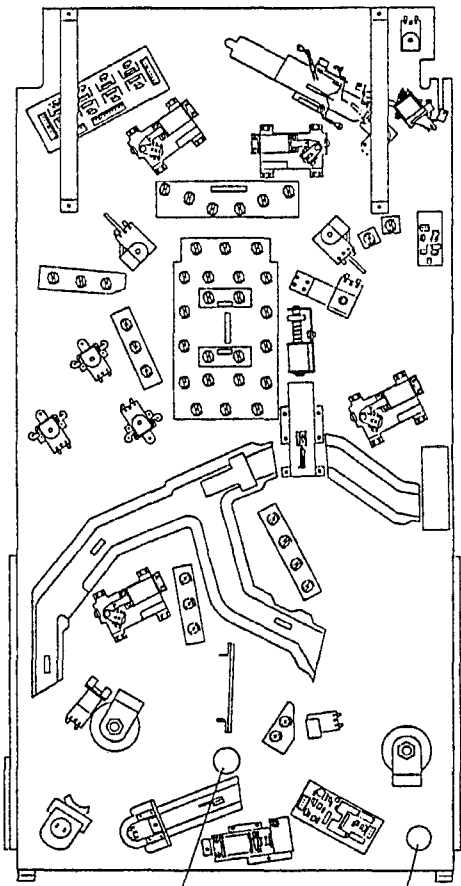

MINI-PLAYFIELD (POWERFIELD) REMOVAL AND REPLACEMENT

Underside of Playfield, Viewed In Raised Position

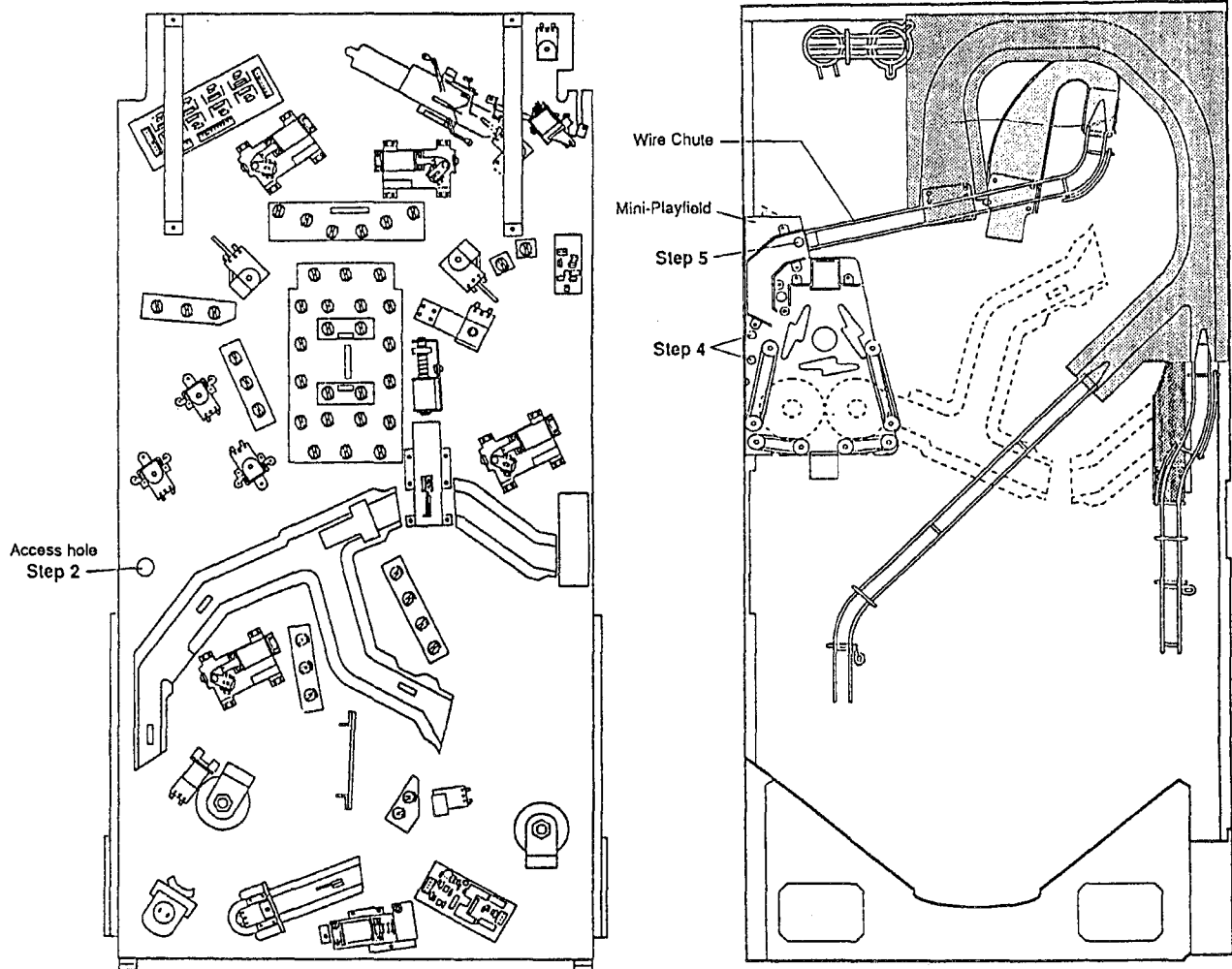

1. Turn power switch OFF.
2. Raise the playfield. On the left side of the playfield about halfway back there is an access hole for the mini-playfield wiring harness. This harness has 4 connectors. Unplug all 4 connectors.
3. Lower the playfield. Leave playfield in its most forward position for easier access to mini--playfield.
4. On the top of the side switch mounting brackets there are 2 nuts, loosen, but do not remove these.
5. Remove the screw that holds the wire chute to the mini-playfield. This screw is located between the chute rails at the mini-playfield entrance.
6. Slide the mini-playfield forwards while working the wiring harness through the playfield.
7. Installation is the reverse procedure from removal.

OPTICAL 3 BALL LOCK ASSEMBLY REMOVAL AND REPLACEMENT

Underside of Playfield, Viewed In Raised Position

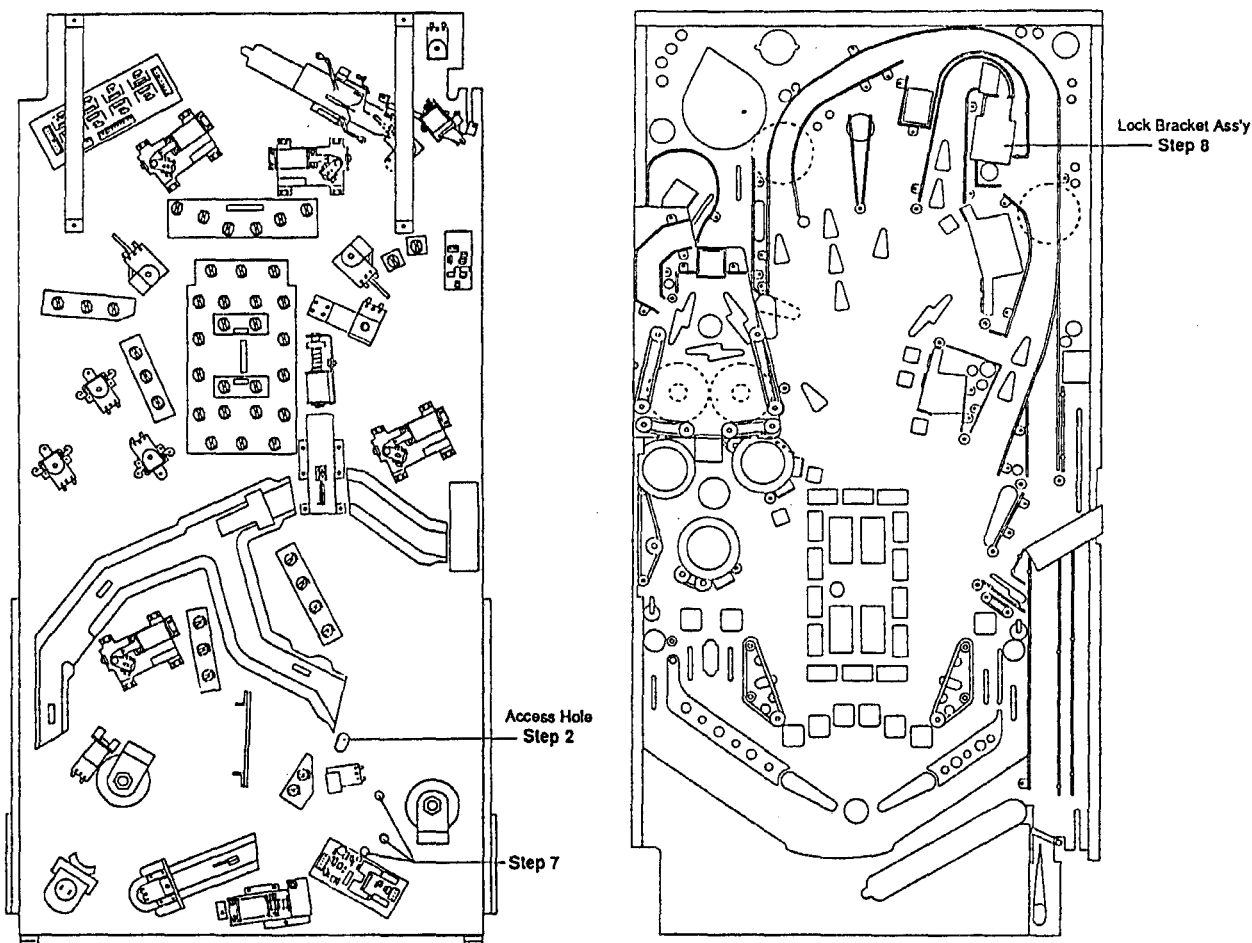

1. Turn power switch OFF.
2. Raise the playfield and separate the connector for the optical switches on the lock bracket. This connector is located in the same area as the clock connectors. Separate the clock harness connectors.
3. Lower the playfield and leave it in the most forward position for easier access.
4. Remove the clock (see Clock Removal, page 3).
5. Remove the 2 nuts that hold the playfield plastic that was under the clock (see Clock Removal, page 50). Remove the plastic.
6. Remove the main right steel ramp (see Main Right Steel Ramp Removal, page 4).
7. Raise the playfield. There are 3 nuts that must be removed from attaching studs for the lock bracket.
8. Lower the playfield. Remove the lock bracket assembly.
9. Reassemble in the reverse order.

Notes...

A series of horizontal dotted lines for writing notes.

SECTION TWO

Game Parts Information

Line Filter/Cordset Application Chart

COUNTRY	LINE FILTER ASSY.			CORDSET								
	A-15707-120V	A-15707-230V		5850-13271-00	5850-13272-00	5850-13273-00	5850-13274-00	5850-13275-00	5850-13276-00	5850-13277-00	5850-13278-00	H-15756
UNITED STATES	✓			✓								
CANADA	✓			✓								
TAIWAN	✓			✓								
MEXICO	✓			✓								
CENTRAL AMERICA	✓			✓								
SOUTH KOREA	✓			✓								
PUERTO RICO	✓			✓								
AUSTRIA		✓			✓							
BELGIUM		✓			✓							
FINLAND		✓			✓							
FRANCE		✓			✓							
GREECE		✓			✓							
HOLLAND		✓			✓							
HUNGARY		✓			✓							
NETHERLANDS		✓			✓							
NETH. ANTILLES		✓			✓							
NORWAY		✓			✓							
POLAND		✓			✓							
PORTUGAL		✓			✓							
SPAIN		✓			✓							
SWEDEN		✓			✓							
TURKEY		✓			✓							
WEST GERMANY		✓			✓							
UNITED KINGDOM		✓				✓						
IRELAND		✓				✓						
HONG KONG		✓				✓						
DENMARK		✓					✓					
ITALY		✓						✓				
CHILE		✓						✓				
PEOPLE'S REP. OF CHINA		✓						✓				
SWITZERLAND		✓							✓			
AUSTRALIA		✓								✓		
NEW ZEALAND		✓								✓		
ARGENTINA		✓								✓		
JAPAN	✓										✓	✓

Cabinet Parts

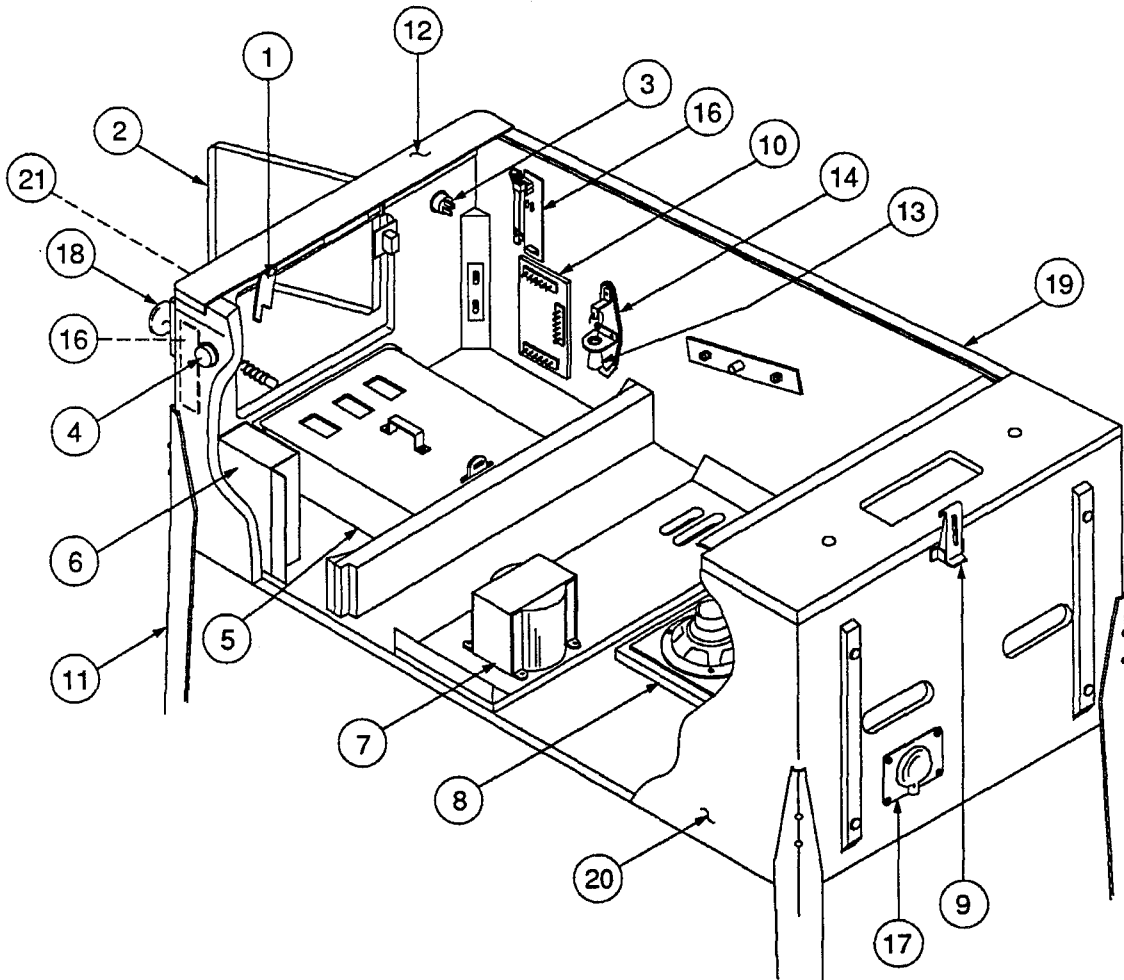

Cabinet Parts:

<u>Item</u>	<u>Part Number</u>	<u>Description</u>	<u>Item</u>	<u>Part Number</u>	<u>Description</u>
1.	A-9174-4	Lever Guide Assembly	17.	01-10714	Line Cord Cover
2.	A-14148-1	Coin Door - 2 Slot	18.	B-12445-6	Ball Shooter Assembly
3.	20-9663-1	Start Button	19.	A-12359-3	Side Molding Assembly
4.	B-12273-6	Flipper Button - Yellow (2 Used)	20.	11-1106	Wood Cabinet
5.	A-16117-1	Cashbox Assembly	21.	A-15896-2	Sw. Button & Cable Assy.
6.	*	Line Filter Assembly			
7.	5610-12835-00	WPC Transformer, 115/230v			
8.	5555-12929-00	Speaker, 4Ω, 6", 25w			
9.	20-9347	Toggle Latch			
10.	A-14689	WPC Coin Door Interface Bd.			
11.	C-10843	Metal Leg Assembly			
12.	A-16055	Front Molding Assembly			
13.	20-6502-A	Plum Bob			
14.	A-15487	Tilt Switch Assembly			
15.	*	Cordset			
16.	A-15878	Double Opto Assy. (2 Used)			

Miscellaneous Parts:

08-7028-1	Tempered Playfield Glass, Wide Body: 23.75" x 43"
20-6500	Steel Ball, 1-1/16" (5)
20-9809	Ceramic Ball (1)
01-10797	Switch Arm

* See Application Chart (p.2-2).

Backbox Assembly

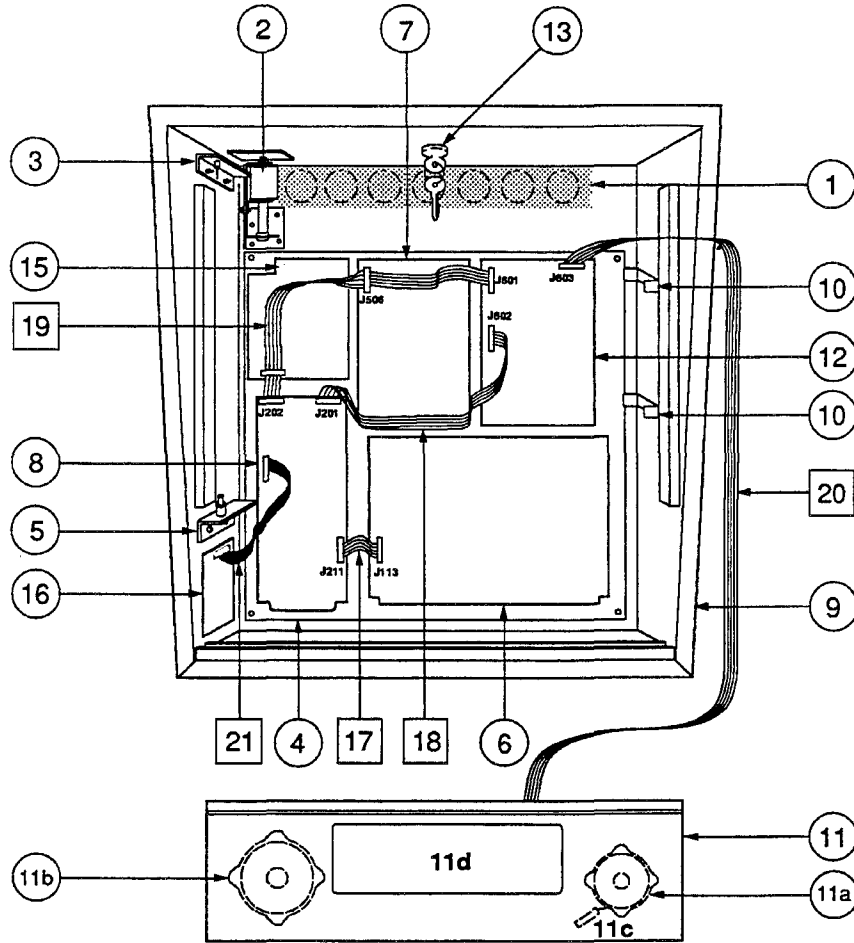

Item	Part Number	Description
1.	01-6645	Venting Screen
2.	B-10686-1	Knocker & Bracket Assy.
3.	A-12497	Upper Insert Bd Hinge Assy.
4.	A-14092-4	Mounting Plate Assembly
5.	A-12498	Lower Insert Bd Hinge Assy.
6.	A-12697-3	Power Driver Assembly
7.	A-12738-50020	WPC Sound Board
8.	A-12742-50020	WPC CPU Board
9.	A-16123	Backbox Assembly
10.	01-9047	Insert Stop Bracket
11.	A-16287	Speaker / Display Assy.
a)	5555-12924-00	Speaker, 4Ω, 15w
b)	5555-12856-00	Speaker, 5-1/4", 4Ω, 25w
c)	5045-12914-00	Cap., 10μfd., 50v, (±20%)
d)	5901-12784-00	Dot Matrix Display/Driver Bd.
12.	A-14039	Dot Matrix Contoller Board
13.	A-13379	Lock & Plate Assembly
a)	20-9637	Lock & Cam Kit

Ribbon Cables:

Item	Part Number	Description
14.	50020-IN	Insert Board
15.	A-15472	Fliptronic II Board
16.	A-16100	8-Driver PCB Assembly
17.	5795-12653-03	Ribbon Cable, 3"
18.	5795-13018-00	Ribbon Cable, 22"
19.	5795-10938-14	Ribbon Cable, 14"
20.	5795-12838-30	Ribbon Cable, 30"
21.	5795-10938-30	Ribbon Cable, 9"

Miscellaneous Parts:

A-8552-50020	Tempered Backglass Assy.
08-7456	Backbox Glass: 27" x 18-7/8"
31-1357-50020	Screened Translight
03-8228-2	Glass Channel Top (1)
03-8228-3	Glass Channel Edge (2)
03-8229-1	Glass Lift Channel (1)

A-15472 Fliptronic II Board

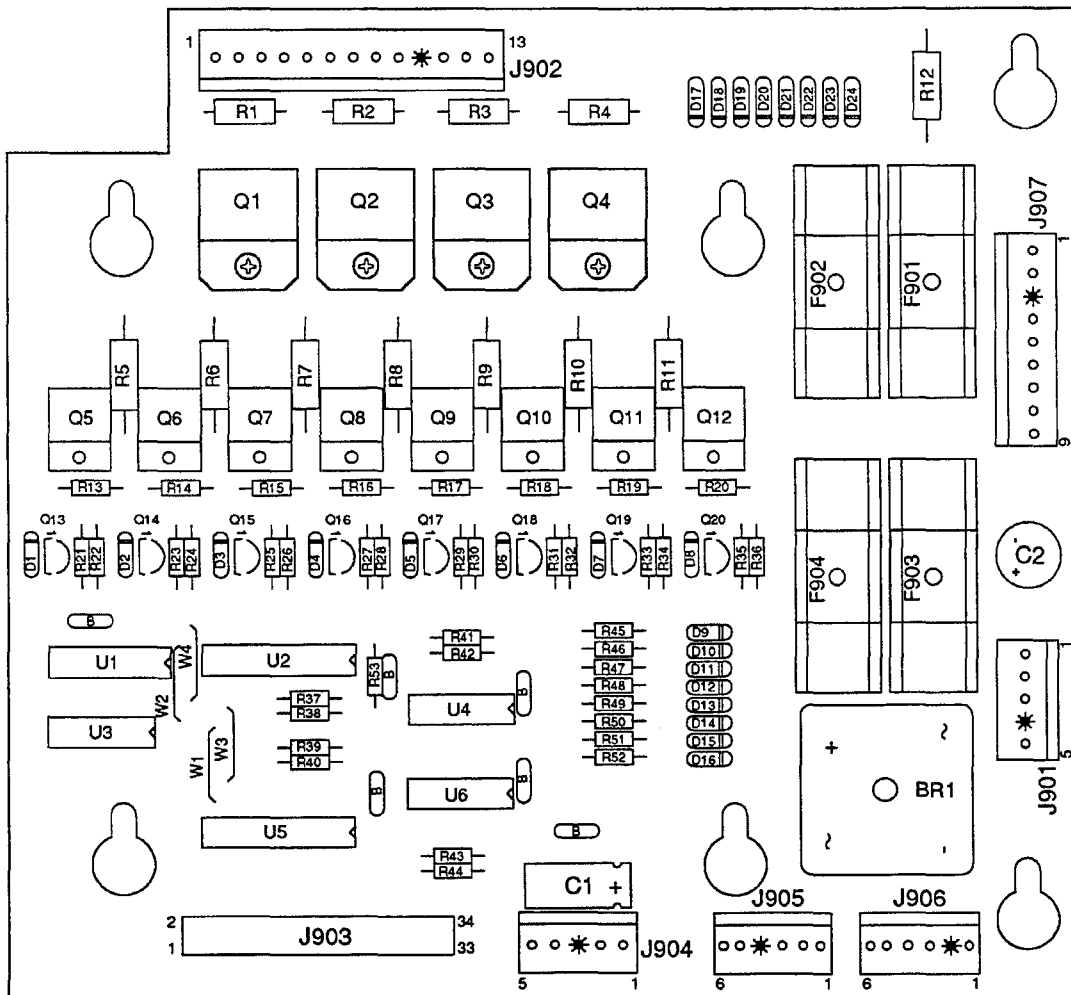

Part Number	Designator	Description
01-10572	Q1-Q4	Heatsink
20-9684	Q5-Q12	Fastener Snap
4006-01003-08	Q1-Q4	Mach. Screw, 6-32
4406-01128-00	Q1-Q4	Nut 6-32 KEPS
5010-09034-00	R37 - R44, R53	Resistor, 10K Ω , 1/4w, 5%
5010-09358-00	R22, R24, R26, R28, R30, R32, R34, R36, R45 - R52	Resistor, 1K Ω , 1/4w, 5%
5010-09361-00	R1 - R4	Resistor, 220 Ω , 1/2w, 5%
5010-09416-00	R21, R23, R25, R27, R29, R31, R33, R35	Resistor, 470 Ω , 1/4w, 5%
5010-09534-00	W3, W4	Resistor, 0 Ω
5010-10171-00	R13 - R20	Resistor, 56 Ω , 1/4w, 5%
5011-12956-00	R5 - R12	Resistor, 2.7K Ω , 1w, 5%
5040-08986-00	C1	Capacitor, 100M, 10v
5043-08980-00	B	Capacitor, .01 μ F, 50v
5040-09537-00	C2	Capacitor, 100 μ F, 100v

Part Number	Designator	Description
5070-09054-00	D1 - D24	Diode1N4004
5162-12635-00	Q5-Q12	Transistor TIP102 NPN
5190-09016-005	Q13 - Q20	Transistor 2N4403 PNP
191-12179-00	Q1-Q4	Transistor TIP36C PNP
5315-12009-00	U2	IC 74HCT374
5315-12031-00	U5	IC 74HCT244
5315-12812-00	U1	IC 74HCT138
5315-12951-00	U3	IC 74HCT00
5370-12272-00	U4, U6	IC LM339 QUAD COMP
5791-10862-09	J907	Connector, 9-pin Header Sq. Pin
5791-10862-05	J901, J904	Connector, 5-pin Header Sq. Pin
5791-10862-13	J902	Connector, 13-pin Header Sq. Pin
5791-12461-06	J905, J906	Connector, Str Sq. Pin Header .100
5791-12516-00	J903	34 HEN 2x17 STR
5100-09690-00	BR1	Bridge Rectifier
5731-10356-00	F901 - F904	Fuse S-B, 3A., 250v
5733-12060-01	-	Fuse Holder (F901-F904)

A-12738-50020 WPC Audio Board

Part No.	Designator	Description	Part No.	Designator	Description
01-9980		Shield: Wire Protector	5048-12748-00	C9, C11, C30	Capacitor, 220pfd., 50V
4004-01005-06	U1	Mach. Screw, 4-40 x 3/8	5070-08919-00	D5, D6	Diode, 1N4148
4104-01012-04	U1	Sh. Mach. Screw, #4 x 1/4	5070-09045-00	D1-D4	Diode MR501, 3.0A
4404-01119-00	U1	Nut, 4-40 SNUT	5250-10495-00	U3	Reg. 7912 1.0A -12v.
5010-08772-00	R21	Resistor, 15K Ω , 1/4w, 5%	5281-09215-00	U22	IC, 74LS04 Hex INV
5010-12065-00	R22, R25	Resistor, 120K Ω , 1/4w, 5%	5281-09246-00	U12	IC, 74LS139 2-4 Dec.
5010-08991-00	R51	Resistor, 4.7K Ω , 1/4w, 5%	5281-09486-00	U28-U30	IC, 74LS374 8 Dual Flipflop
5010-10987-00	R23, R24	Resistor, 56K Ω , 1/4w, 5%	5281-09487-00	U6, U23-U25	IC, 74LS74 Dual Flipflop
5010-09034-00	R13, R14, R29-R31, R33, R34, R50, R45-R49	Resistor, 10K Ω , 1/4w, 5%	5281-09500-00	U31	IC, 74LS32
5010-09035-00	R4	Resistor, 47K Ω , 1/4w, 5%	5281-09745-00	U26, U27	IC, 74LS138 DMLTPX
5010-09036-00	R35	Resistor, 100 Ω , 1/4w, 5%	5281-09850-00	U20	IC, 74LS11 Tripple AND
5010-09134-00	R1, R2, R6, R8, R9, R11, R12	Resistor, 150K Ω , 1/4w, 5%	5281-10577-00	U16	IC, 74LS125 Q/B Bfr
5010-09162-00	R26, R102	Resistor, 100K Ω , 1/4w, 5%	5370-11086-00	U10	IC, YM2151 Sound
5010-08774-00	R3, R5, R17, R19	Resistor, 22K, 1/4w, 5%	5371-11087-00	U11	IC, YM3012 D/A
5010-09269-00	R15	Resistor, 12K Ω , 1/4w, 5%	5400-10320-00	U13	IC, MPU 68B09E
5010-09358-00	R18, R32	Resistor, 1K Ω , 1/4w, 5%	5284-12651-00	U21	IC 4584
5010-09416-00	R28, R36, R37, R39-R44 R52, R53, R57	Resistor, 470 Ω , 1/4w, 5%	5340-12278-00	U9	S/Ram 2064
5010-09534-00	W3, W5, W7-W10	Resistor, 0 Ω	5370-09691-00	U17	IC, 55536 CVSD
5010-10171-00	R38, R56	Resistor, 56 Ω , 1/4w, 5%	5370-12260-00	U2	IC, 3340 Elec Atten
5010-10258-00	R16	Resistor, 1M, 1/4w, 5%	5370-12728-00	U1	IC, Audio Amp LM1875
5010-10650-00	R7, R10	Resistor, 62K, 1/4w, 5%	5370-12730-00	U7, U8	IC, Op Amp TL084
5010-10989-00	R54, R55, R27	Resistor, 470K, 1/4w, 5%	5370-12742-00	U32	IC, Op Amp TL082
5010-12752-00	R20	Resistor, 1 Ω , 1/4w, 5%	5371-12727-00	U19	Dac AD7524
5040-08986-00	C3	Capacitor, 100M, 10v (\pm 20%)	5432-12726-00	U5	EE Prom Pot X9503
5040-09332-00	C15, C18, C34, C36, C38	Capacitor, 47 μ fd., 25v, Axial	5460-12423-00	U4	IC, LM7812
5040-11036-00	C32, C35	Capacitor, 47 μ fd., 16v, Rad	5460-12743-00	U33	LM7809 TO-220
5040-12729-00	C24, C25	Capacitor, 4700 μ fd., 35v.	5520-09020-00	X1	Crystal, 3.58 MHz.
5040-12750-00	C22	Capacitor, 22 μ fd., 35v, Rad.	5521-10931-00	OSC1	Oscillator, 8.0 MHz.
5041-09031-00	C26-C29, C37, C46-C48	Capacitor, 1 μ fd. TANT	5551-09822-00	L1	Ind, 4.7UH 3.0A.
5041-09243-00	C20, C21	Capacitor, 10 μ fd. TANT	5700-08985-00	U13	Socket, IC 40-pin, .6"
5043-08980-00	C41-C44, B(15)	Capacitor, .01M, 50v, (+80, -20)	5700-09004-00	U10	Socket, IC 24-pin, .6"
5043-08996-00	C1, C2	Capacitor, .1 μ fd., 50v, 10%	5700-09006-00	U11	Socket, IC 16-pin, .3"
5048-11027-00	C8, C10	Capacitor, 33pfd., 50v, 10%	A-5343-50020-6	U14	IC, Audio ROM
5048-11028-00	C45	Capacitor, 22pfd., 50V, Axial	A-5343-50020-7	U15	IC, Audio ROM
5048-11029-00	C33, C49	Capacitor, 100pfd., 50v	A-5343-50020-8	U18	IC, Audio ROM
5048-11030-00	C12	Capacitor, 470pfd., 50v	5700-12088-00	U1	Socket, IC 32-pin (U15, U18)
5048-11031-00	C19, C31	Capacitor, .001 μ fd., 50v, 10%	5705-12755-00		Heatsink 5299B-220
5048-11065-00	C13	Capacitor, .0022 μ fd., 50v, 10%, Ax.	5731-10356-00	F501, F502	Fuse, 3A, S-B, 250v
5048-11072-00	C39, C40	Capacitor, .0033 μ fd.	5733-12060-01		Fuse Holder (F501, F502)
5048-12036-00	C23	Capacitor, .22 μ fd., 10v, Ceramic	5791-10862-04	J504, J505	Connector, 4-pin Header Sq. .156
5048-12745-00	C4, C6	Capacitor, 1800pfd., 50V, 10%	5791-10862-05	J502	Connector, 5-pin Header Sq. .156
5048-12746-00	C5, C7	Capacitor, 330pfd., 50V	5791-10862-07	J501	Connector, 7-pin Header Sq. .156
			5791-12462-03	J509	Connector, 3-pin Header Sq. .100
			5791-12462-04	J508	Connector, 4-pin Header Sq. .100
			5791-12516-00	J506	34 Hen 2x17 STR

A-12738-50020 WPC Audio Board

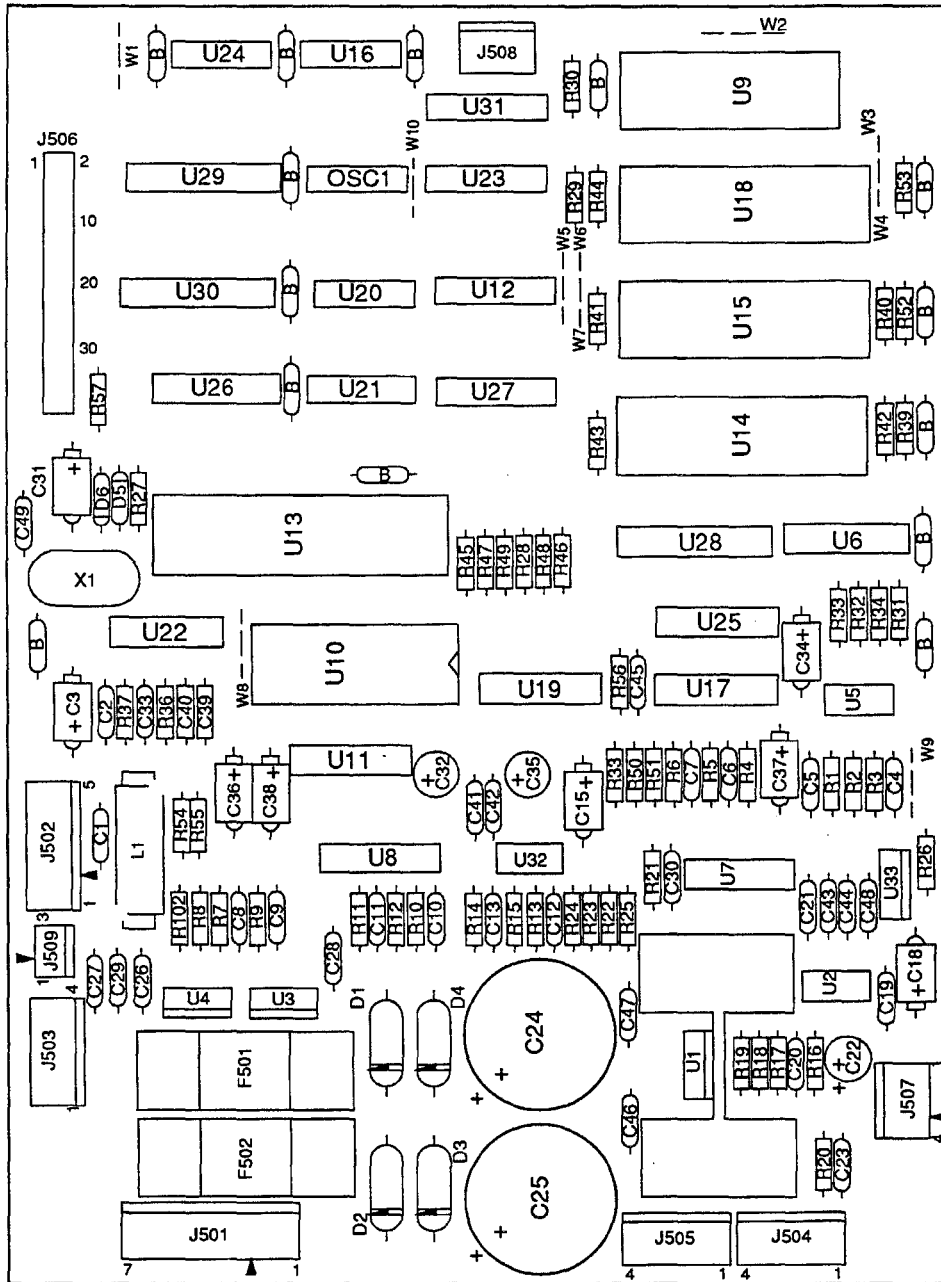

A-12742-50020 WPC CPU Board

<u>Item</u>	<u>Part Number</u>	<u>Designator</u>	<u>Description</u>
1	5010-09034-00	R14-R22, R27-R42, R86, R90, R94, R98	Resistor, 10K Ω , 1/4w, 5%
2	5010-09085-00	R1, R2, R4, R93, R96, R97	Resistor, 1.5K Ω , 1/4w, 5%
3	5010-09314-00	R52, R54, R56, R58, R60, R62, R64, R66, R75-R82	Resistor, 1.2K Ω , 1/4w, 5%
4	5010-09358-00	R3, R43-R51, R53, R55, R57, R59, R61, R63, R65, R67-R74, R84	Resistor, 1K Ω , 1/4w, 5%
5	5010-09416-00	R5-R8, R12, R13, R87-R89	Resistor, 470 Ω , 1/4w, 5%
6	5010-09534-00	W1, W4, W7, W13 - W18	Resistor, 0 Ω
7	5010-10258-00	R95, R99	Resistor, .01 μ fd Ω , 1/4w, 5%
8	5010-10989-00	R92	Resistor, 470K Ω , 1/4w, 5%
9	5010-12104-00	R91	Resistor, 22 μ fd, 1/4w, 5%
10	5019-09362-00	SIP 1	SIP, 9R, 10-pin, 4.7K Ω , 5%
11	5040-08986-00	C31	Capacitor, 100 μ fd, 10v (\pm 20%)
12	5043-08980-00	B	Capacitor, .01 μ fd, 50v, (+80, -20%)
13	5043-09030-00	C27	Capacitor, 0.047 μ fd, 50v (\pm 20%)
14	5043-09065-00	C3 - C26	Capacitor, 470pfd, 50v (\pm 20%)
15	5043-09491-00	C2, C29, C30, C34	Capacitor, 22pfd, 1KV, (\pm 10%)
16	5043-09492-00	C28	Capacitor, 100pfd, 50v, (\pm 10%)
17	5043-09845-00	C32, C33	Capacitor, 1KP, 50v, (\pm 20%)
18	5070-08919-00	D2 - D18	Diode, 1N4148, 150MA
19	5070-09266-00	D1, D25	Diode, 1N5817, 1.0A.
20	5160-10269-00	Q1	Transistor, 2N3904, NPN
21	5162-12422-00	U20	IC, ULN, 2803A
22	5281-09308-00	U3	IC, 74LS245, Octal Bus Trncv
23	5281-09486-00	U14	IC, 74LS374, 8D F/F
24	5281-09851-00	U5	IC, 74LS14, SMT/TRG
25	5281-09867-00	U1, U2, U7	IC, Octal Buffer, 74LS244
26	5281-10182-00	U11, U12, U13, U15	IC, 74LS240 Driver
27	5284-12651-00	U21	IC, 4584
28	5340-12278-00	U8	S/RAM 2064
29	5370-12272-00	U16 - U19	IC, LM339, Quad. Comp
30	5370-12687-00	U10	MC, 34064 Reset Chip
31	5520-10438-00	X2	Crystal, 8.0MHz.
32	5520-12084-00	X1	Crystal 32.768 KHz
33	5551-09822-00	L1	ILN, 4.7 UH 3A
34	5671-09019-00	D19 - D21	DSPL LED RED
35	5700-08985-00	U4	Socket, IC 40P, .6"
36	5700-12088-00	U6	Socket, IC 32P, .6"
37	5700-12424-00	U9	Socket, 84 Pin PLCC
38	5791-10850-00	J201, J204	Connector, 26-pin Header Str Sq.
39	5791-10862-07	J210	Connector, 7-pin Header Str Sq.
40	5791-12461-08	J212	Connector, 8-pin Header Str Sq.
41	5791-12461-09	J206 - J209	Connector, 9-pin Header Sq. pin
42	5791-12461-12	J205	Connector, 12-pin Header Sq. pin
43	5791-12516-00	J202, J211	34 Hen 2x17 STR
44	5881-09021-00	B1 - B3	Battery Holder "AA"
45	5048-11033-00	C50	Capacitor, 0.022 μ f, 10v
47	A-5343-50020-1	U6	Game PROM Assembly
48	5410-12426-00	U9	WPC-89 ASIC
49	5400-10320-00	U4	IC MPU 68B09E
50	5880-09022-00	B1 - B3	Battery, Alkaline, 1.5v ("AA")

A-12742-50020 WPC CPU Board

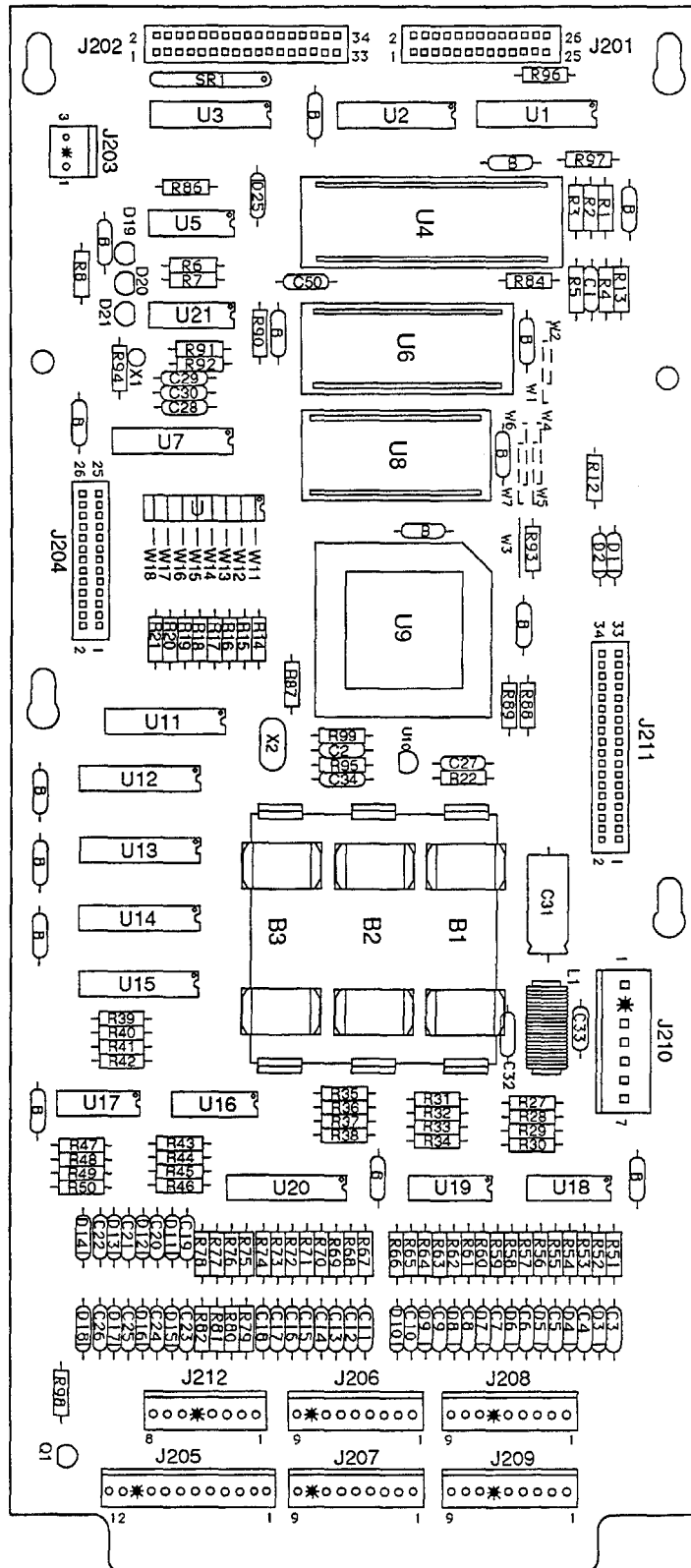

A-12697-3 WPC Power Driver Assembly

Item	Part Number	Ckt Designator	Description	Item	Part Number	Ckt Designator	Description
1	Not Used			32	5043-08996-00	C13-C20, C31	Capacitor, .1µfd, 50v (±20%)
2	4006-01005-06	Q1, Q2	Mach. Screw, 6-32 x 3/8	33	5043-09845-00	C1, C12	Capacitor, 1,000pfd, 50v (±20%)
3	4406-01128-00	Q1, Q2	Nut, 6-32 KEPS	34	5048-10994-00	C3	Capacitor, .33µfd, 50v (±20%) Ax.
4	4004-01005-06	Q10, Q12, Q14, Q16, Q18	Mach. Screw, 4-40 x 3/8	35	5070-08919-00	D33, D34	Diode, 1N4148, 150MA.
5	4404-01119-00	Q10, Q12, Q14, Q16, Q18	Nut, 4-40 SNUT	36	5070-09054-00	D1-D3, D5-D12, D17-D32, D38	Diode, 1N4004, 1.0A.
6	5010-08981-00	R260	Resistor, 10KΩ, 1/2w, 5%	37	5100-09690-00	BR1-BR5	Bridge Rectifier, 35A., 200v
7	5010-08991-00	R9, R12, R15, R18, R21, R23, R27, R31, R35, R39, R43, R47, R51, R55, R59, R63, R67, R71, R75, R79, R83, R87, R91, R95, R99, R126, R128, R130, R132, R134, R136, R138, R140, R227	Resistor, 4.7KΩ, 14w, 5%	38	5131-12725-00	Q10, Q12, Q14, Q16, Q18	Triac, BT138E
8	5010-08992-00	R8, R11, R14, R17, R20, R177, R179, R181, R183, R185, R187, R189, R191	Resistor, 560Ω, 1/4w, 5%	39	5162-12422-00	U19	IC, ULN 2803
9	5010-08993-00	R25, R29, R33, R37, R41, R45, R49, R53, R57, R61, R65, R69, R73, R77, R81, R85, R89, R93, R97, R101, R103, R106, R109, R112, R115, R118, R121, R124	Resistor, 68Ω, 1/4w, 5%	40	5162-12635-00	Q20, Q22, Q24, Q26, Q28, Q30, Q32, Q34, Q36, Q38, Q40, Q42, Q44, Q46, Q48, Q50, Q52, Q54, Q56, Q58, Q63, Q65, Q67, Q69, Q75, Q77, Q79, Q81, Q83 - Q90	Transistor, TIP 102
10	5010-08997-00	R24, R28, R32, R36, R40, R44, R48, R52, R56, R60, R64, R68, R72, R76, R80, R84, R88, R92, R96, R100, R102, R105, R108, R111, R114, R117, R120, R123, R195	Resistor, 2.7KΩ, 1/4w, 5%	41	5194-09055-00	Q9, Q11, Q13, Q15, Q17, Q19, Q21, Q23, Q25, Q27, Q29, Q31, Q33, Q35, Q37, Q39, Q41, Q43, Q45, Q47, Q49, Q51, Q53, Q55, Q57, Q59-Q62, Q71-Q74	Transistor, 2N5401 PNP
11	5010-08998-00	R155, R157, R159, R161, R165, R167, R169, R171	Resistor, 2.2KΩ, 1/4w, 5%	42	5191-12179-00	Q64, Q66, Q68, Q70, Q76 Q78, Q80, Q82	Transistor, TIP36C PNP
12	5010-09034-00	R3, R4, R6, R142-R149, R197, R198	Resistor, 10KΩ, 1/4w, 5%	43	5192-12428-00	Q91-Q98	Transistor, TIP 107
13	5010-09085-00	R194, R196, R251, R253-R257	Resistor, 1.5KΩ, 1/4w, 5%	44	5250-12634-00	Q1	Reg LM 323 5v
14	5010-09086-00	R252	Resistor, 6.8KΩ, 1/4w, 5%	45	5281-09486-00	U1-U5, U18	IC, 74LS374 8 Dual D Flipflop
15	5010-09224-00	R1, R2, R192, R201, R205, R208	Resistor, 270Ω, 1/4w, 5%	46	5281-09487-00	U10-U13	IC, 74LS74 Dual D flipflop
16	5010-09314-00	R176, R178, R180, R182, R184, R186, R188, R190	Resistor, 1.2KΩ, 1/4w, 5%	47	5281-10182-00	U9	IC, 74LS240, L/Dvrr
17	5010-09324-00	R206	Resistor, 27KΩ, 1/4w, 5%	48	5370-12272-00	U6, U15, U16	IC, LM339 Quad. Comp
18	5010-09358-00	R154, R156, R158, R160, R164, R166, R168, R170, R162, R193, R199, R200, R250	Resistor, 1KΩ, 1/4w, 5%	49	5460-12423-00	Q2	IC, LM 7812
19	5010-09361-00	R104, R107, R110, R113, R116, R119, R122, R125	Resistor, 220Ω, 1/4w, 5%	50	Not Used		
20	5010-09416-00	R22, R26, R30, R34, R38, R42, R46, R50, R54, R58, R62, R66, R70, R74, R78, R82, R86, R90, R94, R98, R127, R129, R131, R133, R135, R137, R139, R141	Resistor, 470Ω, 1/4w, 5%	51	Not Used		
21	5010-09534-00	W1, W2	Resistor, 0Ω	52	5671-09019-00	LED1 - LED7	Display LED Red
22	5010-11079-00	R7, R10, R13, R16, R19	Resistor, 51Ω, 1/4w, 5%	53	5701-09652-00	Q1	Thermal Pad TO-3
23	5010-12427-00	R150-R153, R172-R175	Resistor, .22Ω, 1w, 5%	54	5705-09199-00	Q2	Heatsink #6030B
24	5012-12632-00	R224	Resistor, .12Ω, 10w, 5%	55	Not Used		
25	Not Used			56	5705-12637-00	Q1	Heatsink 5054
26	5019-10143-00	SR1	SIP, 9R, 10 pin, 470Ω, 5%	57	5705-12638-00	Q10, Q12, Q14, Q16, Q18	Heatsink 5298B
27	5040-08986-00	C4	Capacitor, 100µfd, 10v (±20%)	58	5733-12060-01		Fuse Holder, F101-F116
28	5040-09421-00	C2	Capacitor, 100µfd, 25v (+50, -10%)	59	Not Used		
29	5040-09537-00	C8	Capacitor, 100µfd, 100v (±20%)	60	5791-10862-03	J108, J119, J136	Connector, 3-pin Header STR Sq.
30	5040-12313-00	C5, C6, C7, C11, C30	Capacitor, 15,000µfd, 25v (±20%)	61	5791-10862-04	J103, J116-J118	Connector, 4-pin Header STR Sq.
31	5043-08980-00	B-BYPASS	Capacitor, .01µfd, 50v (+80, -20%)	62	5791-10862-05	J112, J104-J106, J123, J124, J128, J129, J131, J132	Connector, 5-pin Header STR Sq.
				63	5791-10862-06	J107	Connector, 6-pin Header STR Sq.
				64	5791-10862-07	J101, J109, J114	Connector, 7-pin Header STR Sq.
				65	5791-10862-09	J102, J122, J125, J127, J130, J137, J138	Connector, 9-pin Header STR Sq.
				66	5791-10862-11	J120, J121	Connector, 11-pin Header STR Sq.
				67	5791-10862-12	J115	Connector, 12-pin Header STR Sq.
				68	5791-10862-13	J126	Connector, 13-pin Header STR Sq.
				69	5791-12461-05	J111	Connector, 5-pin Header STR Sq.
				70	5791-12461-09	J133-J135	Connector, 9-pin Header STR Sq.
				71	5791-12516-00	J113	34 HEN 2x17 STR
				72	5824-09248-00	TP1-TP8	Test Point #1502-1
				73	5041-09163-00	C9	Capacitor, 2.2µfd TANT
				74-100	Not Used		
				101	Not Used		
				102	5730-09071-00	F114	Fuse, 8A, 32v
				103	Not Used		
				104	5711-09432-00	F112	Fuse, S-B, 7A., 250v
				105	5711-09651-00	F106 - F111, F113	Fuse, S-B, 5A., 250v
				106	Not Used		
				107	5731-10356-00	F101 - F105, F116	Fuse, S-B, 3A., 250v
				108	5730-09797-00	F115	Fuse, S-B, 3/4A., 250v
				109	5705-12698-00		Heatsink #62365
				110	4010-01006-00		Mach. Screw, 10-32 x 5/8

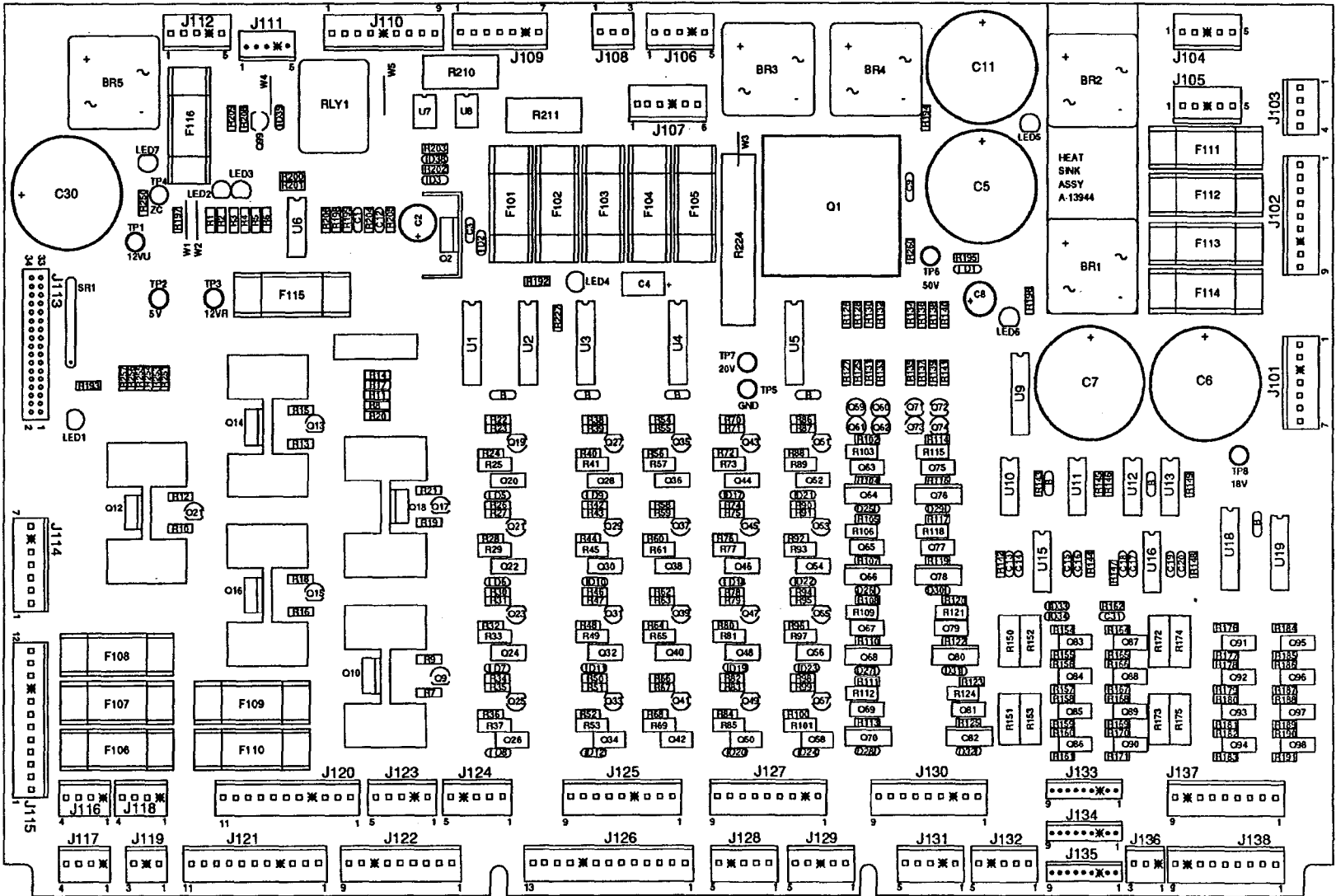

Twilight Zone 2-11

<u>Part Number</u>	<u>Ckt Designator</u>	<u>Description</u>
5010-08991-00	R1	Resistor, 4.7K Ω , 1/4w, 5%
5010-09224-00	R10	Resistor, 270 Ω , 1/4w, 5%
5010-12832-00	R3, R6, R12, R13	Resistor, 47K Ω , 1/2w, 5%
5010-12841-00	R4, R5	Resistor, 120 Ω , 1/2w, 5%
5012-12830-00	R9	Resistor, 1.8K Ω , 5w, 5%
5012-12842-00	R11	Resistor, 120 Ω , 5w, 5%
5012-12843-00	R8	Resistor, 4.7K, 5w, 5%
5010-10171-00	R7	Resistor, 56 Ω , 1/4w, 5%
5040-08986-00	C3	Capacitor, 100 μ fd., 10v, (\pm 20%)
5040-12324-00	C4, C7	Capacitor, 150 μ fd., 160v, (\pm 50%)
5043-08980-00	BYPASS	Capacitor, .01 μ fd., 50v, (+80, -20%)
5043-09072-00	C6, C9, C10	Capacitor, .1 μ fd., 500v, (+80, -20%)
5043-09845-00	C1, C2, C11	Capacitor, 1KP, 50v, (\pm 20%)
5043-09492-00	C5, C8	Capacitor, 100P, 50v, (\pm 10%)
5070-09054-00	D7	Diode, 1N4004, 1.0A.
5075-12824-00	D6, D8	Zener, 1N4742A, 12v
5075-12823-00	D4, D5	Zener, 1N4758A, 62v
5075-12826-00	D3	Zener, 1N4759A, 62v
5100-12833-00	BR1, BR2	Bridge, 400v, 1A.
5160-10269-00	Q1	Transistor, 2N3904 NPN
5164-09056-00	Q2, Q10	Transistor, MPSD02, NPN
5164-12154-00	Q3, Q7	Transistor, MJE15030 NPN
5194-09055-00	Q4, Q5	Transistor, MPSD52 PNP
5194-12155-00	Q6	Transistor, MJE15031 PNP
5281-09738-00	U16, U25 - U27	IC, 74LS157
5281-10033-00	U3	IC, 74LS30
5281-10043-00	U31 - U33, U35	IC, 74LS175
5311-10946-00	U4, U5, U17, U18, U20	IC, 74HC74
5311-10947-00	U9	IC, 74HC125
5311-10951-00	U10, U11	IC, 74HC161
5311-10977-00	U6	IC, 74HC04
5311-12817-00	U29	IC, 74HC165
5311-12819-00	U21	IC, 74HC688
5311-12820-00	U23	IC, 74HC27
5311-12822-00	U13 - U15	IC, 74HC193
5315-12009-00	U22	IC, 74HCT374
5315-12812-00	U1, U2, U30	IC, 74HCT138
5281-09308-00	U28	IC, 74HCT245
5315-12815-00	U8, U34	IC, 74HCT08
5315-12816-00	U19	IC, 74HCT32
5315-12821-00	U7	IC, 74HCT240
5340-12278-00	U24	S/RAM 2064 150NS
5551-09822-00	L1	IND 4.7 μ H, 3.0A.
5671-09019-00	D10	Display LED Red
5705-09199-00	Q3, Q6, Q7	Heatsink 6030B
5731-12328-00	F601, F602	Fuse, 3/8A., SB, 250v
5733-12060-00		Fuse Holder (F601, F602)
5791-10850-00	J602	Connector, 26-pin STR Sq.
5791-10862-05	J605	Connector, 5-pin Header Sq.
5791-10862-07	J606	Connector, 7-pin Header Sq.
5791-10862-08	J604	Connector, 8-pin Header Sq.
5791-12516-00	J601	34 Hen 17x2 STR
5791-12827-00	J603	14 Hen 7x2 STR
5010-09036-00	R14-R23	Resistor, 100 Ω , 1/4w, 5%
4006-01003-06	Q3, Q6, Q7	Mach. Screw, 6-32 x 3/8
4406-01128-00	Q3, Q6, Q7	Nut, 6-32 KEPS

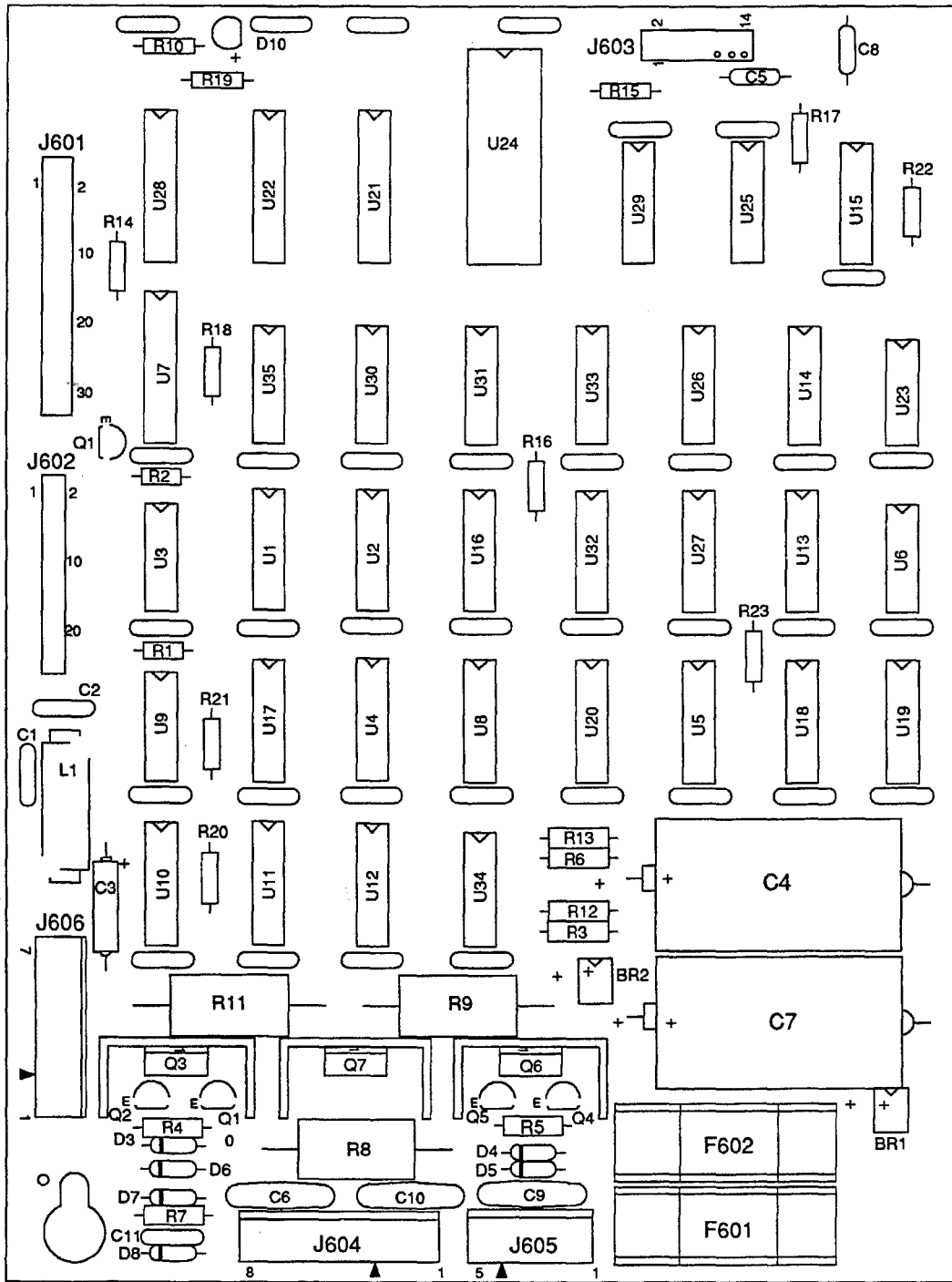

A-14689 WPC Coin Door Interface Board

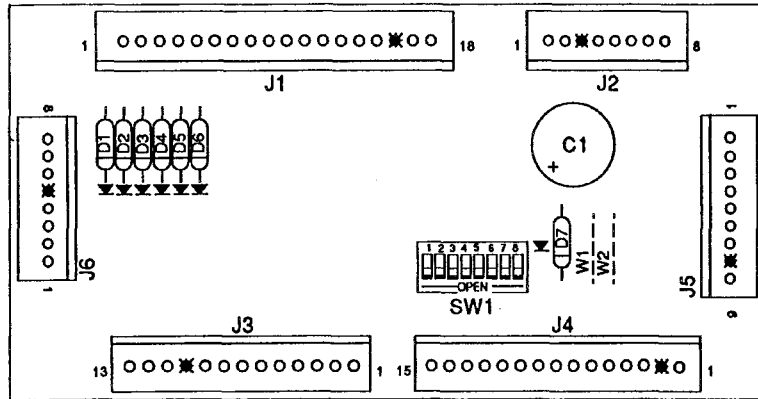

Part Number	Designator	Description
5070-09054-00	D1-D7	Diode, 1N4004, 1.0A.
5791-10862-18	J1	Connector, 18-pin Header Str Sq.
5791-10862-08	J2, J6	Connector, 8-pin Header Str Sq.
5791-10862-13	J3	Connector, 13-pin Header Str Sq.
* 5791-10862-15	J4	Connector, 15-pin Header Str Sq.
* 5791-10862-09	J5	Connector, 9-pin Header Str Sq.
* 5645-09025-00	SW1	Switch DIP 8-Position

Notes:

- For Belgium, France, Finland, Sweden and England use A-14689-1 Coin Door Interface Board.
- * = Used on Electronic Coin Door only.

Twilight Zone 2-14

A-15878 Double Flipper Opto Assembly

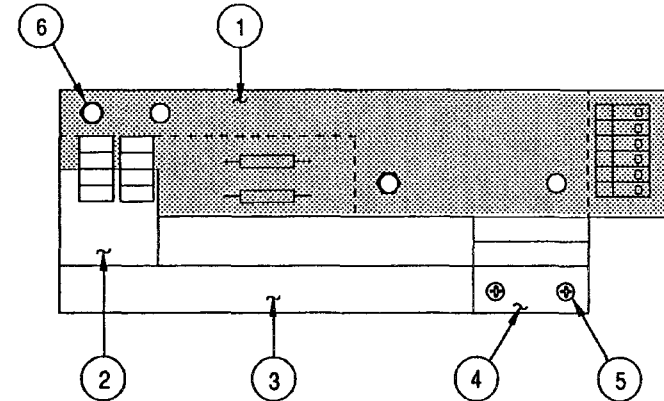

Item	Part Number	Description
1.	A-15894	PC Board Assembly
	5010-08930-00	Resistor 470Ω, 1/2w, 5%
	5490-12451-00	Opto Inter Lg. 10ma.
	5791-12273-07	Connector, 7-pin Header
2.	01-10939	Interrupter Opto
3.	06-86	Back Up Blade (2)
4.	A-15893	Opto Board Mtg. Bracket
5.	4006-01003-04	MS 6-32 x 1/4 P-PH (2)
6.	4406-01119-00	Nut #6 ESN (2)

A-16116 8-High Power Driver PCB Assembly

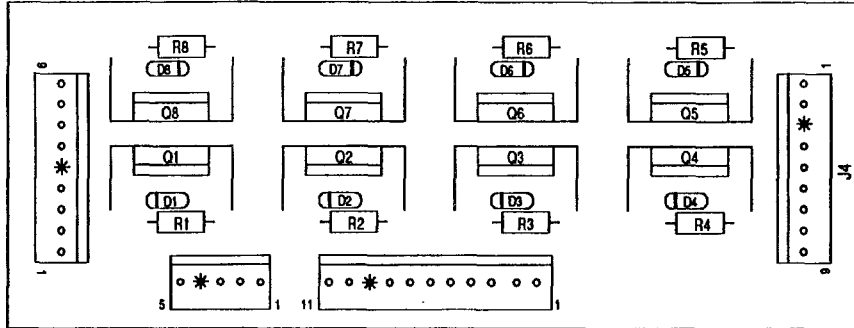

<u>Part Number</u>	<u>Designator</u>	<u>Description</u>
5070-09054-00	D3 - D8	Diode 1N4004, 1.0a
5010-09361-00	R3 -R8	Resistor, 220Ω, 1/2w, 5%
5791-10862-09	J1, J4	Connector, 9-pin Header Str Sq .156
5791-10862-05	J2	Connector, 5-pin Header Str Sq .156
5791-10862-11	J3	Connector, 11-pin Header Str Sq .156
5705-13404-00	Q3 - Q8	Heatsink
5191-12179-00	Q3 - Q8	Trans TIP36C PNP
4006-01003-06	Q3 - Q8	Mach. Screw, 6-32 x 3/8 P-PH-S

A-16120 DC Motor Control Assembly

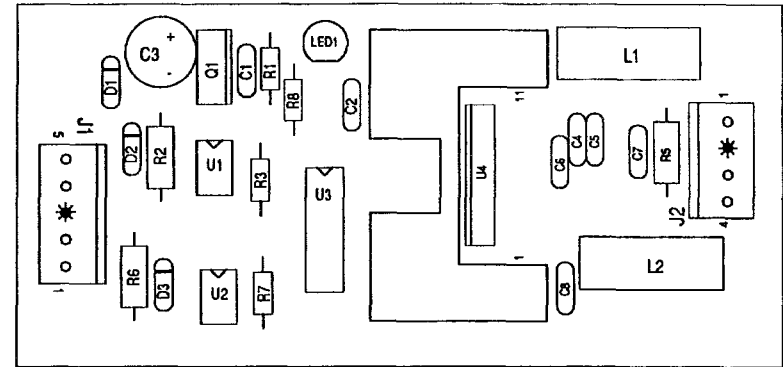

<u>Part Number</u>	<u>Designator</u>	<u>Description</u>
5791-12273-04	J2	Connector, 4-pin Header
5791-12273-05	J1	Connector, 5-pin Header
5671-09019-00	LED1	Display Red LED
5070-09054-00	D1 - D3	Diode 1N4004 1.0A.
5551-09822-00	L1, L2	Ind. 4.7mH, 3.0A.
5010-09061-00	R2, R6	Resistor, 680Ω, 1/2w, 5%
5010-10255-00	R5	Resistor, 10Ω, 1/2w, 5%
5010-08997-00	R3, R7, R8	Resistor, 2.7KΩ, 1/2w, 5%
5010-09085-00	R1	Resistor, 1.5KΩ, 1/2w, 5%
5040-10974-00	C3	Capacitor, 100μFd, 35v Rad
5370-13342-00	U4	IC 3A D.O.S Bridge Driver
5490-10892-00	U1, U2	Opto Isolator 4N25
5250-09157-00	Q1	Reg. 7805 1.0A, 5V
5043-08980-00	C2, C4, C6-C8	Cap., .01μFd, 50v (+80, -20%)
5041-09031-00	C1	Cap., 1μFd, 25v (±20%) Axial
5281-09500-00	U3	IC 74LS32 Quad
5043-08996-00	C5	Capacitor, .1M, 50V (±20%)

A-16100 8-Driver PCB Assembly

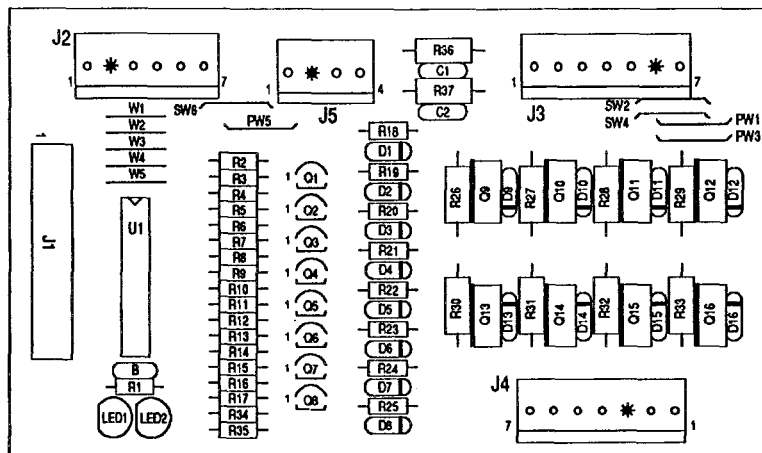

Part Number	Designator	Description
5317-13400-00	U1	IC74ALS576 O/F-F
5190-09016-00	Q1 - Q8	Trans. 2N4403 PNP
5162-12635-00	Q9 - Q16	Trans. TIP 102NPN
5070-09054-00	D1- D16	Diode, 1N4004, 1.0A.
5010-08991-00	R1, R2, R4, R6, R8, R10, R12, R14, R16	Resistor, 4.7KΩ, 1/4w, 5%
5010-09416-00	R3, R5, R7, R9, R11, R13, R15, R17	Resistor, 470Ω, 1/4w, 5%
5043-08980-00	B	Capacitor, .01μF, 50v(+80, -20%)
5010-10171-00	R18 - R25	Resistor, 56Ω, 1/4w, 5%
5011-12956-00	R26 - R33	Resistor, 2.7KΩ, 1/4w, 5%
5010-09314-00	R35	Resistor, 1.2KΩ, 1/4w, 5%
5010-09224-00	R34	Resistor, 270Ω, 1/4w, 5%
5671-09019-00	LED1, LED2	Disp. Red LED
5010-08930-00	R37	Resistor, 470Ω, 1/2w, 5%
5043-09065-00	C2	Capacitor, 470PF, 50v(±20%)
5010-09534-00	W4, SW2, SW4, SW6	Resistor, 0Ω (Jumper)
5791-10850-00	J1	Connector, 26-pin Header Str Sq.100
5791-10862-06	J2	Connector, 6-pin Header Str Sq.100
5791-10862-07	J3, J4	Connector, 7-pin Header Str Sq.100
5791-10862-04	J5	Connector, 4-pin Header Str Sq.100

A-16528 Trough Coil Assembly

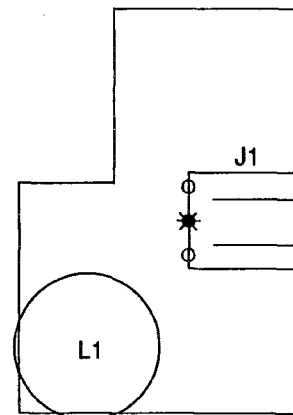

Part Number	Designator	Description
A-16393	L1	Coil Trough Assembly
5791-12548-03	J1	Connector, 3-pin Header 3R/A

A-16220 Minute Opto PCB Assembly

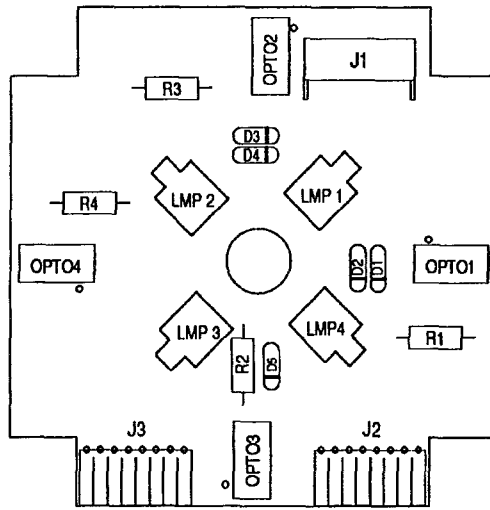

<u>Part Number</u>	<u>Designator</u>	<u>Description</u>
5490-13451-00	OPTO1 - OPTO4	Opto Inter with Long Lead
03-8840	OPTO1 - OPTO4	Spacer
5010-08930-00	R1 - R4	resistor, 470Ω, 1/2w, 5%
5070-09054-00	D5	Diode 1N4004 1.0A.
24-8830	LMP1 - LMP4	Socket Sub-Mini Wedge PCB
24-8829	LMP1 - LMP4	Bulb #86, 6.3, .2A
5791-12622-08	J2, J3	Connector, 8-pin Header
5792-11003-07	J1	PCB Connector
5010-09034-00	D1 - D4	Resistor, 0Ω

A-16219 Hour Opto PCB Assembly

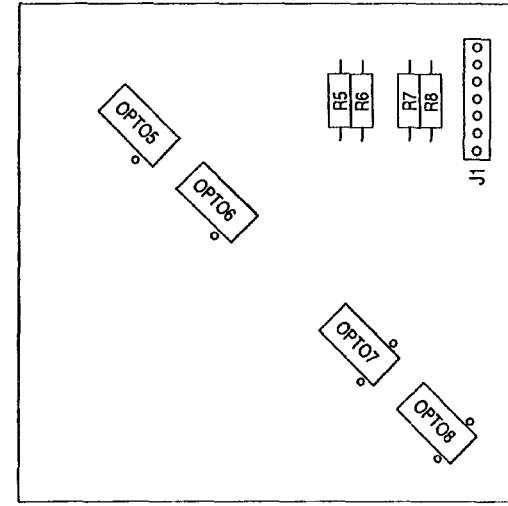

<u>Part Number</u>	<u>Designator</u>	<u>Description</u>
5490-12451-00	OPTO5 - OPTO8	Opto Inter with Long 10mA.
5010-08930-00	R5 - R8	Resistor, 470Ω, 1/2w, 5%
5791-13458-07	J1	Connector, 7-pin Header

A-16535 Ramp Prox Opto Sensor Assy.

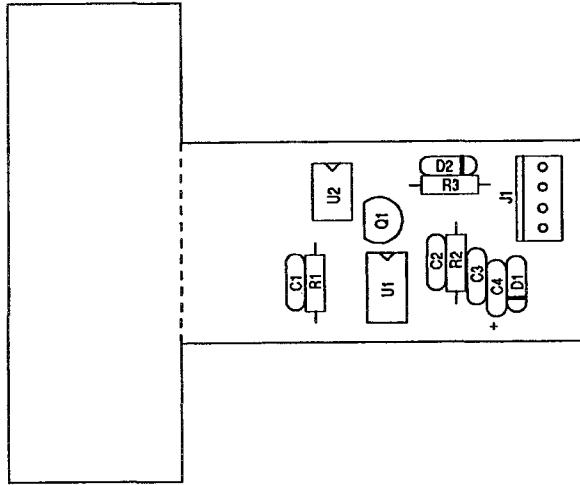

<u>Part Number</u>	<u>Designator</u>	<u>Description</u>
5010-10022-00	R1	Resistor, 7.5K Ω , 1/4w, 5%
5010-10983-00	R2	Resistor, 1.8K Ω , 1/4w, 5%
5041-13187-00	C4	Capacitor, 4.7 μ F, 20v
5048-11064-00	C1	Capacitor, 390pF
5048-12503-00	C2	Capacitor, 10pF
5070-08919-00	D1, D2	Diode, 1N4148
5370-13452-00	U1	I.C. TDA 0161
5490-13507-00	U2	I.C. Opto 100% CTR 4N
5791-12462-00	J1	Connector, 4-pin Header
5671-09019-00	LED	LED Red Display

A-16534 Prox Opto Sensor Assembly

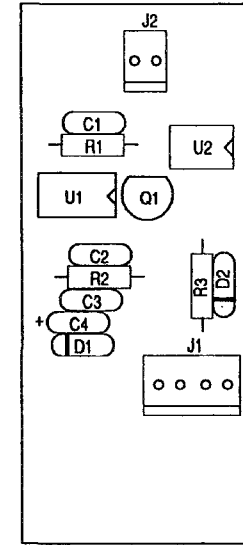

<u>Part Number</u>	<u>Designator</u>	<u>Description</u>
5010-08998-00	R1	Resistor, 2.2K Ω , 1/4w, 5%
5010-10983-00	R2	Resistor, 1.8K Ω , 1/4w, 5%
5041-13187-00	C4	Capacitor, 4.7 μ F, 20v
5048-11064-00	C1	Capacitor, 390pF
5048-12503-00	C2	Capacitor, 10pF
5070-08919-00	D1, D2	Diode, 1N4148
5370-13452-00	U1	I.C. TDA 0161
5490-13507-00	U2	I.C. Opto 100% CTR 4N
5791-12462-02	J2	Connector, 2-pin Header
5791-12462-04	J1	Connector, 4-pin Header
5761-09019-00	LED	LED Red Display

A-15542 Motor EMI Board

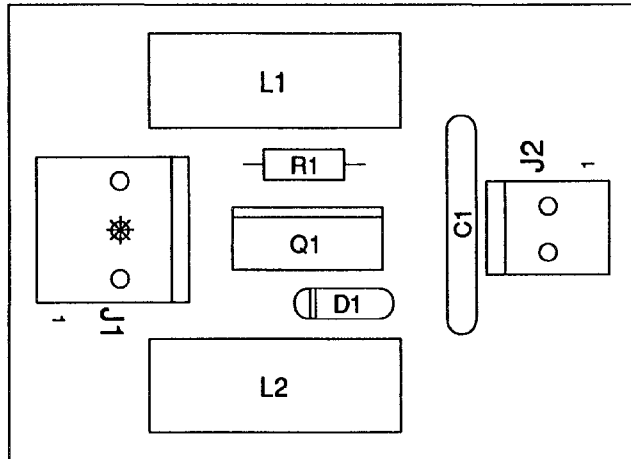

<u>Part Number</u>	<u>Designator</u>	<u>Description</u>
5551-09822-00	L1, L2	Ind. 4.7MH3AMP
5791-12273-03	J1	Connector, 3-pin Header Sq.
5791-12273-02	J2	Connector, 2-pin Header Sq.
5070-09054-00	D1	Diode 1N4004, 1.0A.

A-16807 10-Switch Opto PCB Assembly

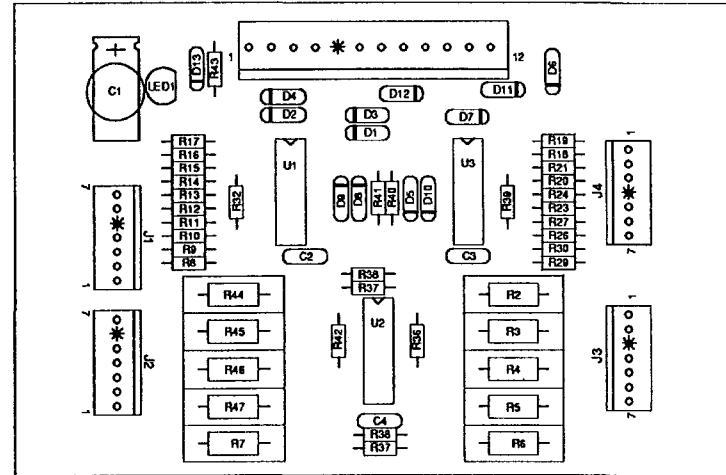

<u>Part Number</u>	<u>Designator</u>	<u>Description</u>
5040-10974-00	C1	Capacitor, 100µfd, 35v
5040-08980-00	C2-C4	Capacitor, 0.01µfd, 50v
5671-09019-00	LED1	Display RED LED 1
5370-12272-00	U1-U3	I.C. LM339 Quad
5070-09054-00	D1-D13	Diode 1N4004, 1.0A.
5010-12928-00	R2-R7, R44, R47	Resistor, 270Ω, 2w, 5%
5010-09999-00	R8-R21, R23, R24, R26, R27, R29, R30	Resistor, 2KΩ, 1/4w, 5%
5010-09314-00	R43	Resistor, 1.2KΩ, 1/4w, 5%
5010-09162-00	R32, R35, R39-R41	Resistor, 100K, 1/4w, 5%
5010-08774-00	R33, R36, R42	Resistor, 22KΩ, 1/4w, 5%
5010-09034-00	R37, R38	Resistor, 10KΩ, 1/4w, 5%
5791-10862-12	J5	Connector, 12-pin Header
5791-12462-07	J1-J4	Connector, 10-pin Header

A-15205-L-1, A-15205-L-4, A-15205-R-3, A-15205-R-4 Fliptronic II Flipper Assembly

<u>Item</u>	<u>Part Number</u>	<u>Description</u>	<u>Flipper Notes:</u>
1.	See Chart	Flipper Base Assembly	<ol style="list-style-type: none"> 1. Each Flipper Assembly is mounted beneath the playfield, in conjunction with the Plastic Flipper & Shaft, and Flipper Rubber on the upper side of the playfield. 2. With the flipper, in the non-activated position, the E.O.S. Switch contacts must have a gap of .062 (± 0.015) inch. When flipper is activated switch must close. 3. Any adjustment of the E.O.S. Switch must be made at a minimum distance of 0.25 inch from the switch body. 4. Longer blade of E.O.S. Switch must be straight. Gap adjustment is done by adjusting shorter blade. 5. All moving elements of the assembly must operate freely without any evidence of binding. 6. Apply Loctite™ 242 when reattaching screws to the Flipper Stop Assembly, the Solenoid Bracket, and the Flipper Bushing.
2.	SW-1A-193	Switch Assembly	
3.	4701-00002-00	Lockwasher, #6 Split	
4.	4105-01019-10	Sh. Metal Screw, #5 x 5/8 P-RH-A	
5.	4008-01079-05	Mach. Screw, 8-32 x 5/16 H-SOC	
6.	4701-00003-00	Lockwasher, #8 Split	
7.	01-9375	Switch Mounting Bracket	
8.	20-6516	Speednut, Tinnerman	
9.	4010-01066-06	Cap Screw, 10-32 x 3/8, SH	
10.	4701-00004-00	Lockwasher, #10 Split	
11.	A-12111	Flipper Stop Assembly	
12.	See Chart	Flipper Coil	
a)	03-7066-5	Coil Tubing	
13.	01-7695	Solenoid Bracket	
14.	4006-01017-04	Mach. Screw, 6-32 x 1/4 P-RH-S	
15.	10-364	Spring	
16.	See Chart	Crank Link Assembly	
a)	See Chart	Flipper Crank Assembly	
b)	A-10656	Flipper Link Assembly	
c)	02-4179	Link Spacer Bushing	
d)	4010-01086-14	Cap Screw, 10-32 x 7/8 SH	
e)	4700-00023-00	Flatwasher, 5/8 x 13/64 x 16ga.	
f)	4701-00004-00	Lockwasher #10 Split	
g)	4410-01132-00	Nut, 10-32 ESN	
17.	23-6577	Bumper Plug, 5/8"	
18.	03-7568	Flipper Bushing	
19.	4006-01005-06	Mach. Screw, 6-32 x 3/8 P-PH	
20.	4406-01117-00	Nut, 6-32 Hex.	

Associated Parts for Left & Right Flippers:

21.	23-6519-4	Flipper Rubber, Yellow (3 used)
	23-6553-4	Flipper Rubber
22.	20-9250-6	Flipper & Shaft, Yellow (3 used)
	20-9264-6	Small Flipper & Shaft

Flipper Assembly Part Number	Item 1	Item 12	Item 16	Item 16a
A-15205-R-3	B-13104-R	FL-11722 (Green)	B-13882-R	B-13884-R
A-15205-R-4	B-13104-R	FL-15411 (Orange)	B-13882-R	B-13884-R
A-15205-L-1	B-13104-L	FL-11753 (Yellow)	B-13882-L	B-13884-L
A-15205-L-4	B-13104-L	FL-15411 (Orange)	B-13882-L	B-13884-L

Fliptronic II Flipper Assembly

A-15205-L-1
A-15205-L-4
A-15205-R-3
A-15205-R-4

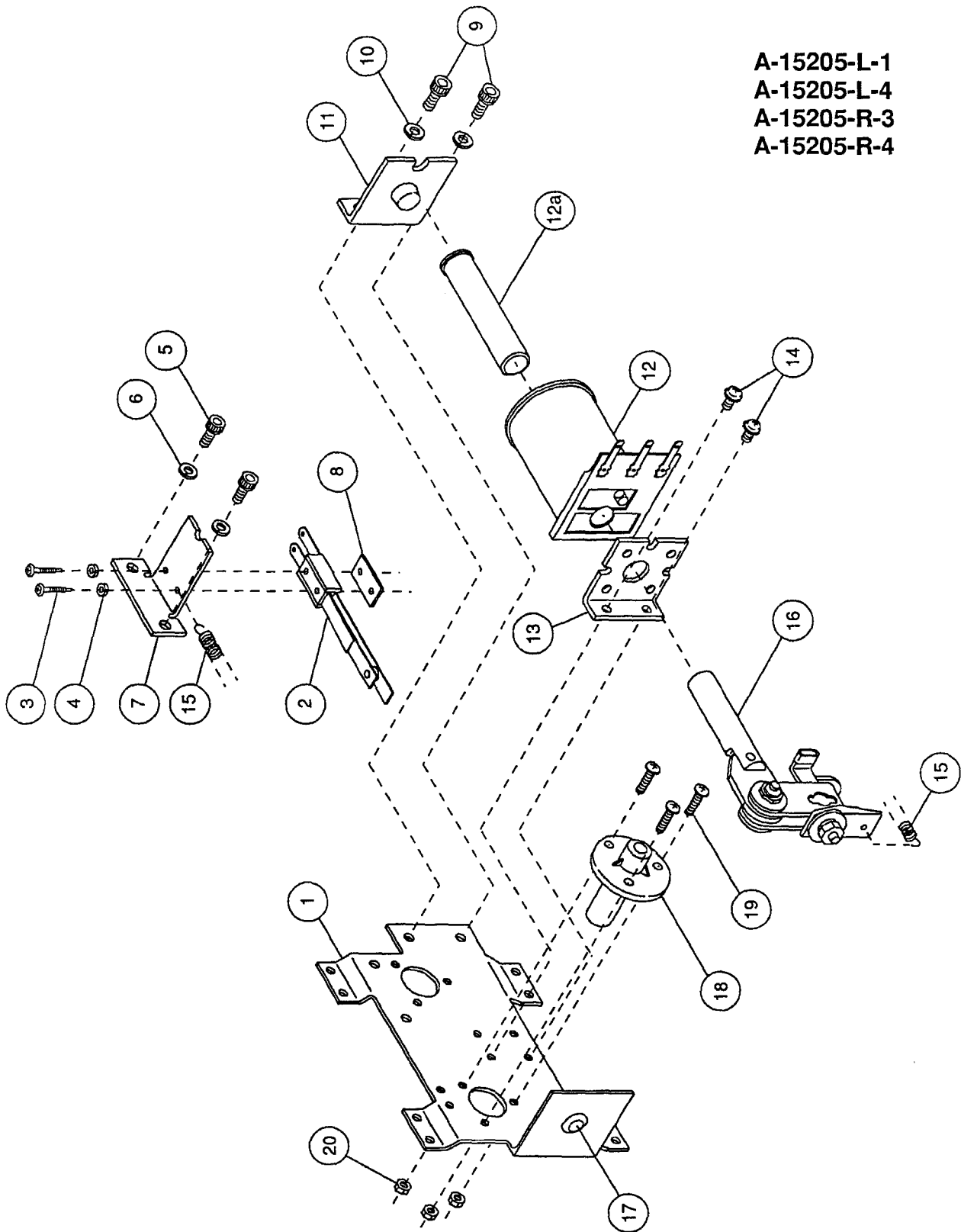

A-8039-3 Outhole Kicker Assembly

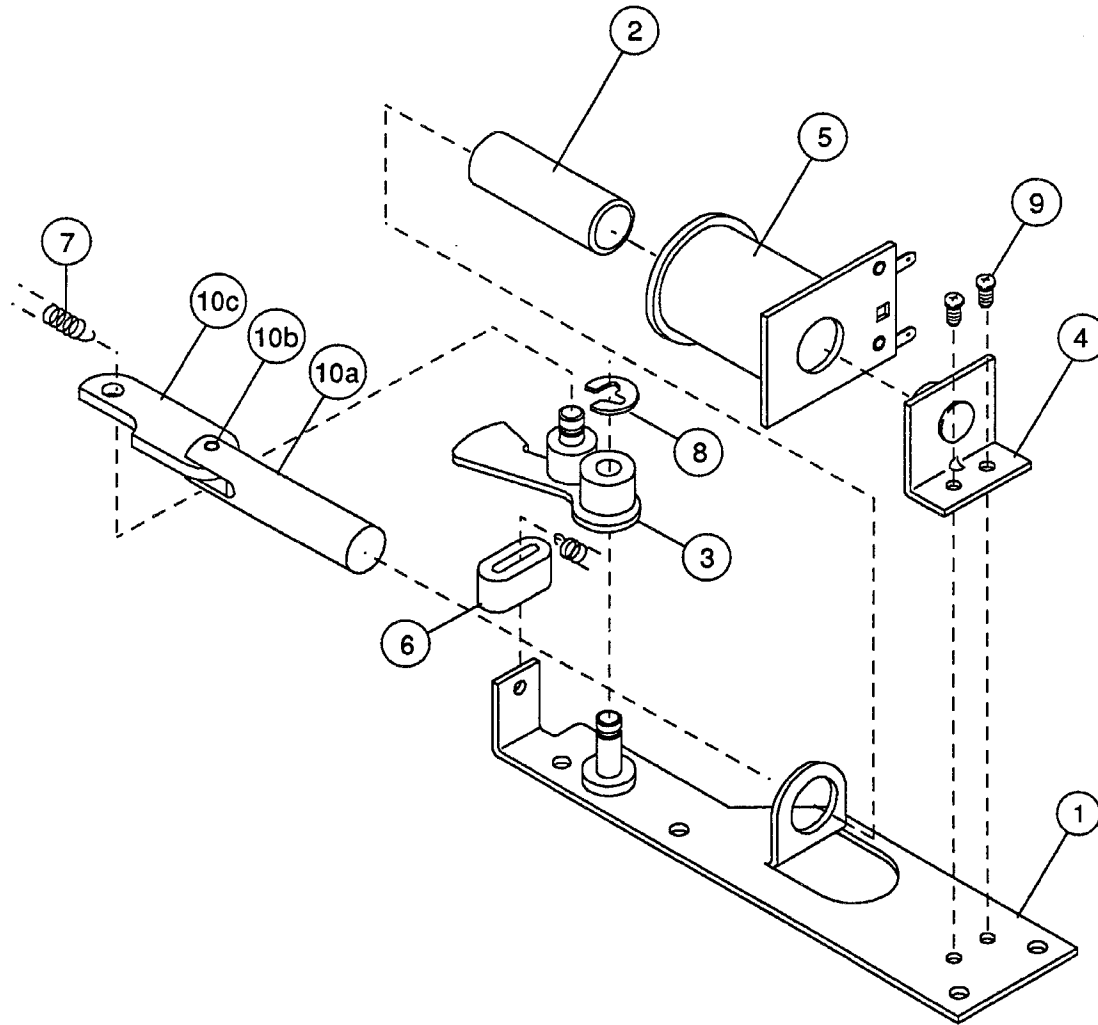

<u>Item</u>	<u>Part Number</u>	<u>Description</u>
1.	A-6378	Mounting Plate Assembly
2.	03-7066	Coil Tubing
3.	A-6889	Kicker Lever Assembly
4.	A-8038	Coil Stop Assembly
5.	AE-27-1200	Coil Assembly
6.	03-7176-1	Striker Ring
7.	10-101-4	Spring-Reset
8.	20-8712-25	"E" Ring, 1/4" Shaft
9.	4006-01003-03	Mach. Screw, 6-32 x 3/16"
10.	A-8335	Coil Plunger Assembly
a)	02-2364	Coil Plunger
b)	20-8716-5	Roll Pin, 1/8 x 7/16"
c)	01-4251	Ball Return Link

C-9638 Ball Shooter Lane Feeder Assembly

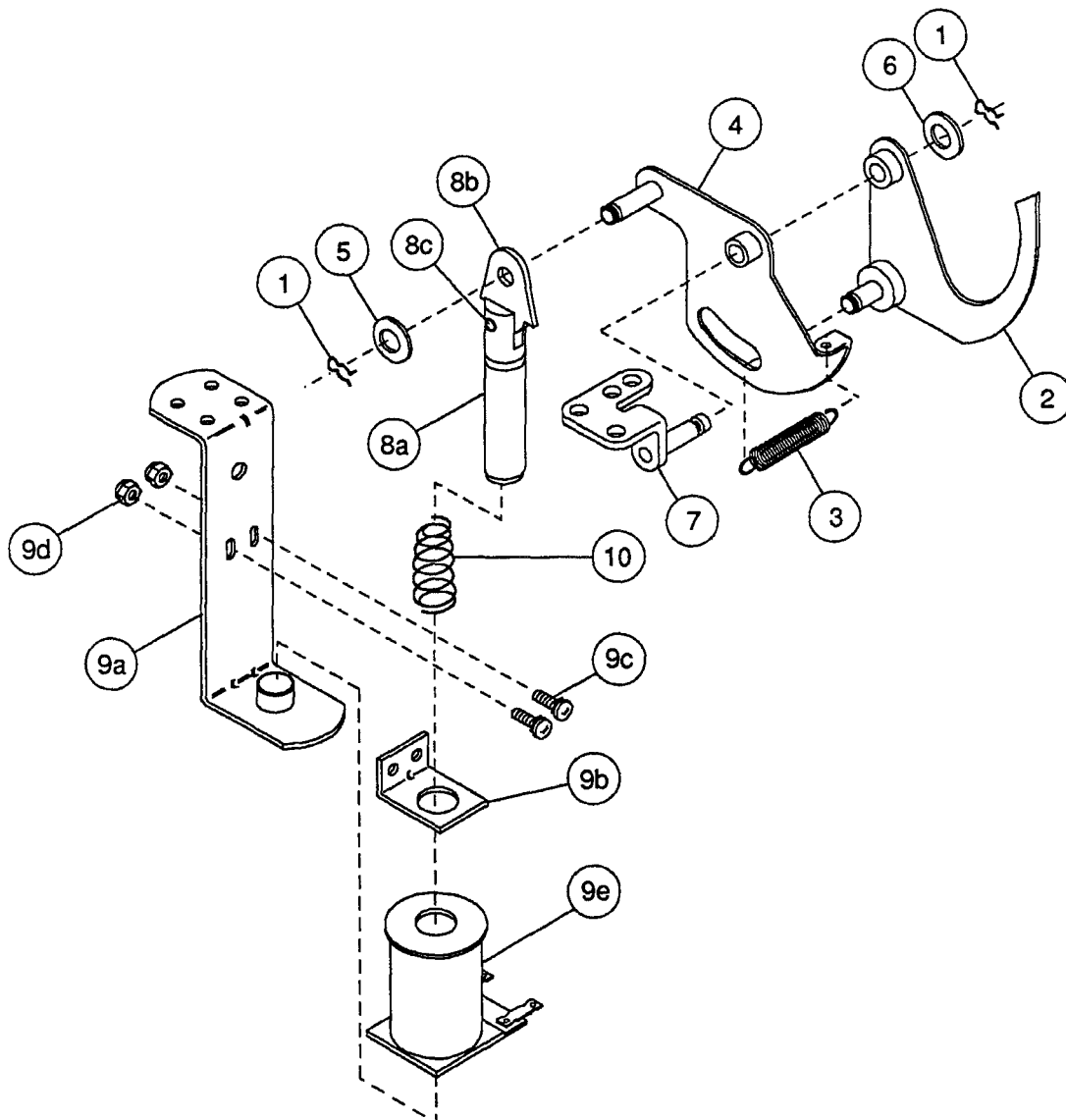

Associated Parts:

<u>Item</u>	<u>Part Number</u>	<u>Description</u>	<u>Item</u>	<u>Part Number</u>	<u>Description</u>
1.	12-6227	Hairpin Clip	9.	A-16766	Coil & Bracket Assembly
2.	A-8247	Eject Cam Assembly	a)	B-7572-1	Bracket & Stop Assembly
3.	10-362	Ejector Spring (Plain)	b)	01-8-508-S	Coil Retaining Bracket
4.	A-6949-L	Spring Plate Assembly	c)	4006-01017-06	Mach. Screw, 6-32 x 3/8
5.	4700-00030-00	Flatwasher, 17/64 x 1/2 x 15ga.	d)	4406-01119-00	Nut, 6-32 ESN
6.	4700-00103-00	Flatwasher, 17/64 x 1/2 x 28ga.	e)	AE-26-1200	Coil Assembly
7.	A-8268	Mounting Bracket Assembly	10.	10-128	Spring
8.	A-8050-1	Coil Plunger Assembly			
a)	02-3407-2	Coil Plunger Assy, 2-1/8"			
b)	03-8085	Armature Link			
c)	20-8716-5	Roll Pin, 1/8 x 7/16"			

B-12665 Kicker Arm (Slingshot) Assembly

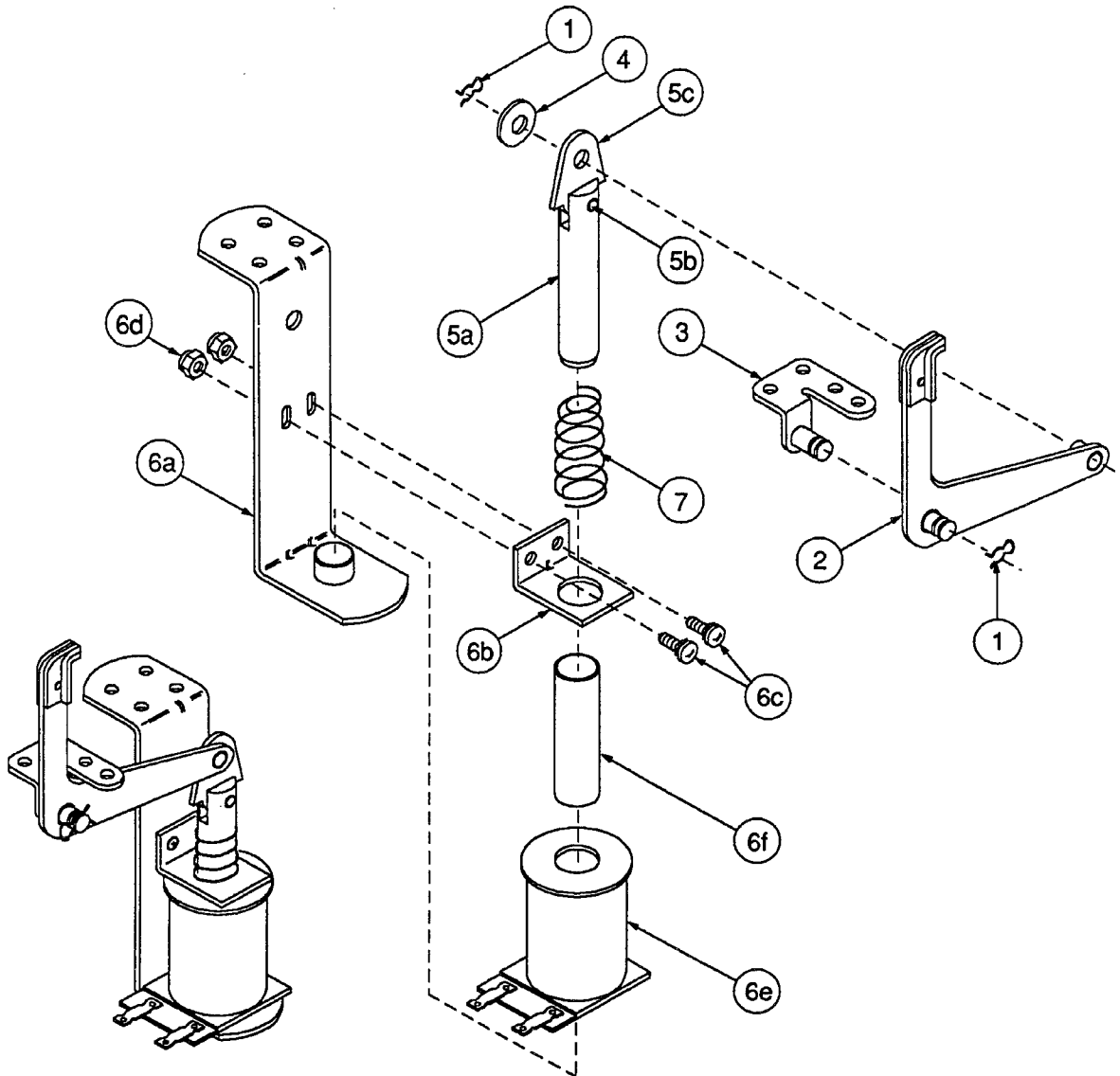

Associated Parts for Right & Left Kickers:

<u>Item</u>	<u>Part Number</u>	<u>Description</u>	<u>Item</u>	<u>Part Number</u>	<u>Description</u>
1.	12-6227	Hairpin Clip	6.	A-16645-R	Coil & Bracket Assy., Right
2.	A-12664	Kicker Crank Assembly		A-16645-L	Coil & Bracket Assy., Left
3.	A-5653	Mounting Bracket Assembly	a)	B-7572-1	Bracket & Stop Assembly
4.	4700-00030-00	Flatwasher, 17/64 x 1/2 x 15ga.	b)	01-8-508-S	Coil Retaining Bracket
5.	A-5103	Coil Plunger Assembly	c)	4006-01017-06	Mach. Screw, 6-32 x 3/8
a)	02-2364	Coil Plunger	d)	4406-01119-00	Nut, 6-32 ESN
b)	03-8085	Armature Link	e)	AE-27-1200	Coil Assembly
c)	20-8716-5	Roll Pin, 1/8 x 7/16"	f)	03-7066	Coil Tubing
			7.	10-128	Spring

A-16312 Ball Popper Assembly

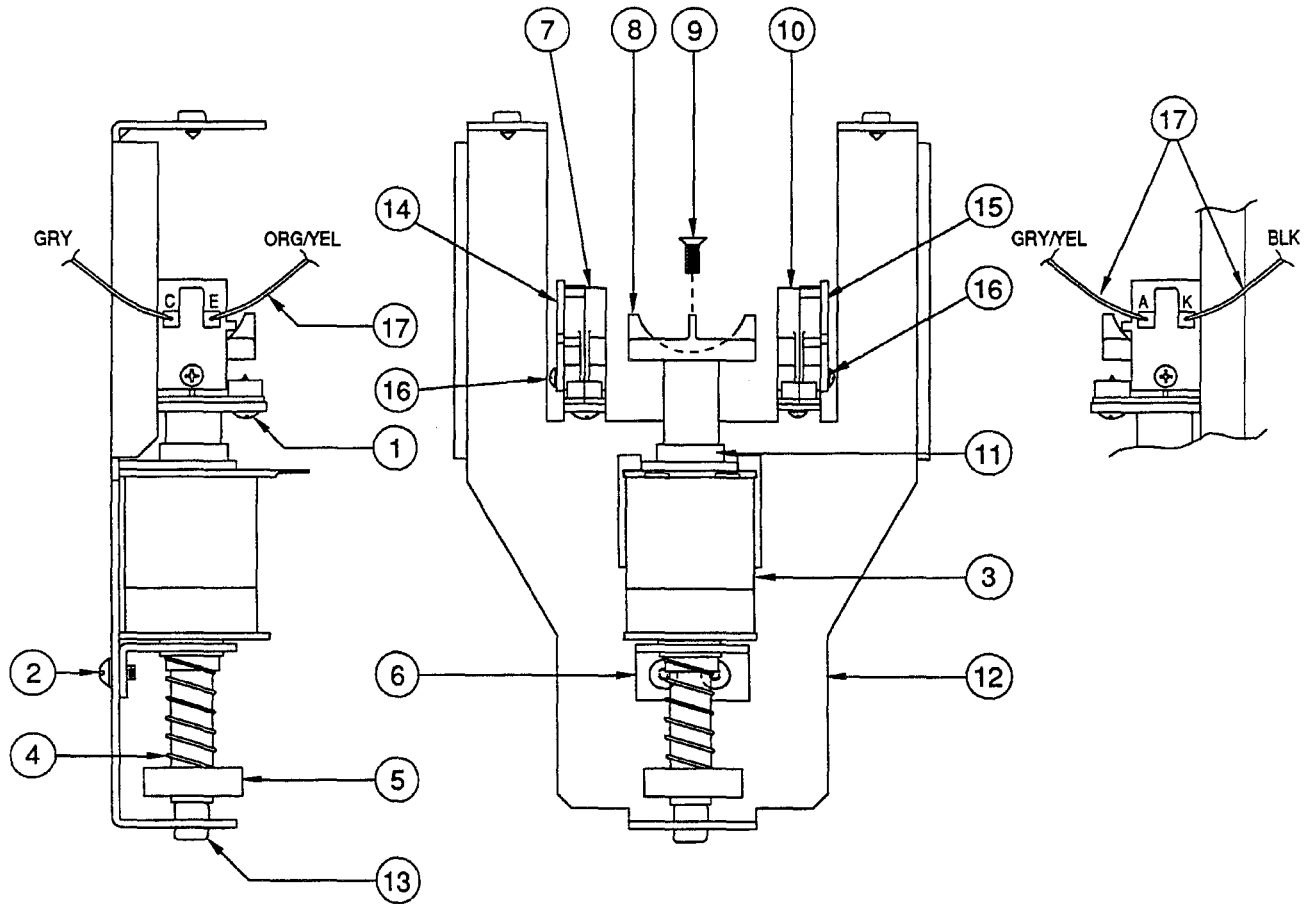

Item	Part Number	Description	Item	Part Number	Description
1.	4106-01013-06	Sh. Metal Screw, #6 x 3/8"	10.	03-8506-1	Opto Mtg. Base, White
2.	4008-01017-05	Mach. Screw, 8-32 x 5/16"	11.	03-7067-5	Coil Tubing
3.	AE-23-800	Coil Assembly	12.	A-16314	Ball Popper Bracket
4.	10-135	Spring Coil Plunger	13.	23-6420	Rubber Grommet
5.	02-4668	Armature Assembly	14.	A-14232	Photo Trans. Assembly
6.	01-9794	Mounting Bracket	15.	A-14231	LED Assembly
7.	03-8506	Opto Mtg. Base, Black	16.	4104-01001-06	Sh. Metal Screw, #4 x 3/8 PH-P-HD
8.	03-8561	Ball Popper Cup	17.	H-16606	Opto Popper Cable
9.	4106-01152-06	Sh. Metal Screw, #6 x 3/8 Thd.			

A-16361 Bridge Diverter Assembly

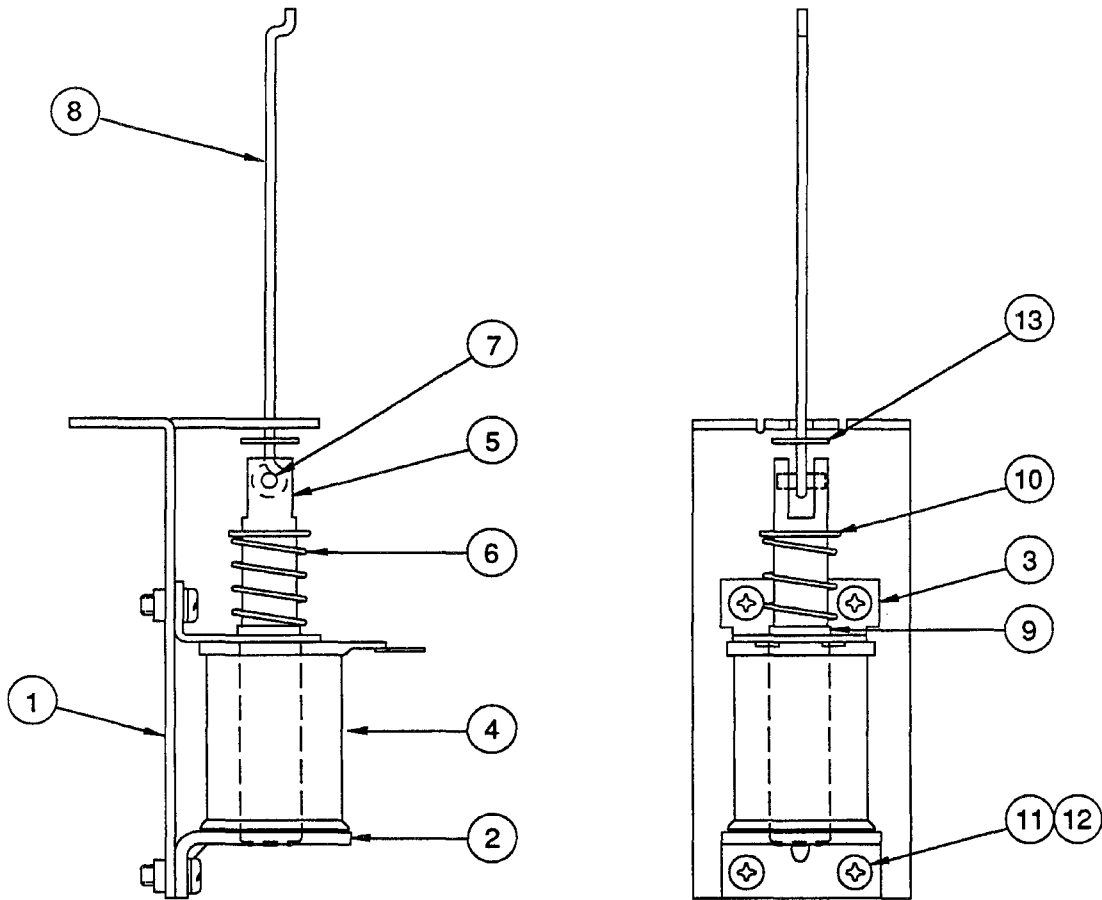

<u>Item</u>	<u>Part Number</u>	<u>Description</u>
1.	A-16496	Bracket Assembly
2.	A-10821	Flipper Stop Bracket Assy.
3.	01-8413	Coil Mounting Bracket
4.	AE-26-1200	Coil Assembly
5.	02-4731	Solenoid Plunger
6.	10-437	Spring Kicker
7.	20-8716-5	Roll Pin, 1/8 x 7/16" Lg.
8.	12-7082	Actuator
9.	03-7066	Coil Tubing
10.	20-8712-43	"E" Retaining Ring
11.	4010-01008-06	Mach. Screw, 10-32 x 3/8 P-PH
12.	4701-00004-00	Lockwasher, #10 Split
13.	4700-00132-00	Flatwasher, 5/64 x 7/16 x 28ga.

A-16064 Right Diverter Assembly

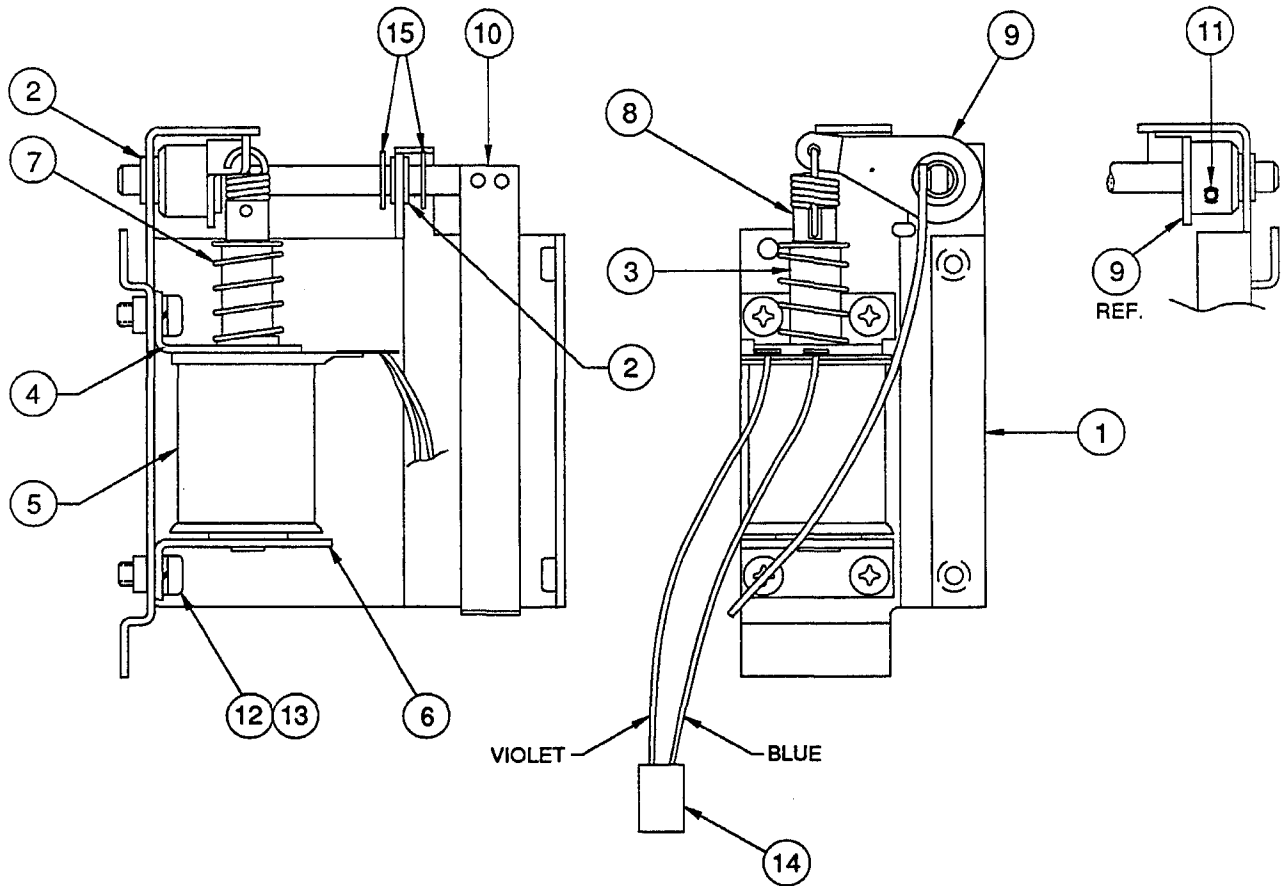

<u>Item</u>	<u>Part Number</u>	<u>Description</u>
1.	A-16063	Right Diverter Bracket
2.	20-8790	Nylined Bearing
3.	03-7066	Coil Tubing
4.	01-8413	Coil Mounting Bracket
5.	AR-26-1500	Coil Assembly
6.	A-10821	Flipper Stop Bracket Assembly
7.	10-437	Kicker Spring
8.	A-13278	Plunger Assembly
9.	A-14185	Drive Arm Assembly
10.	A-16114	Diverter Assembly
11.	4010-01082-04	Set Screw, 10-32 x 1/4"
12.	4010-01008-06	Mach. Screw, 10-32 x 3/8 P-PH
13.	4701-00004-00	Lockwasher, #10 Split
14.	H-16611	Cable Assembly
15.	20-8712-25	"E"-Ring, 1/4" Shaft

A-16313 Rear Diverter Assembly

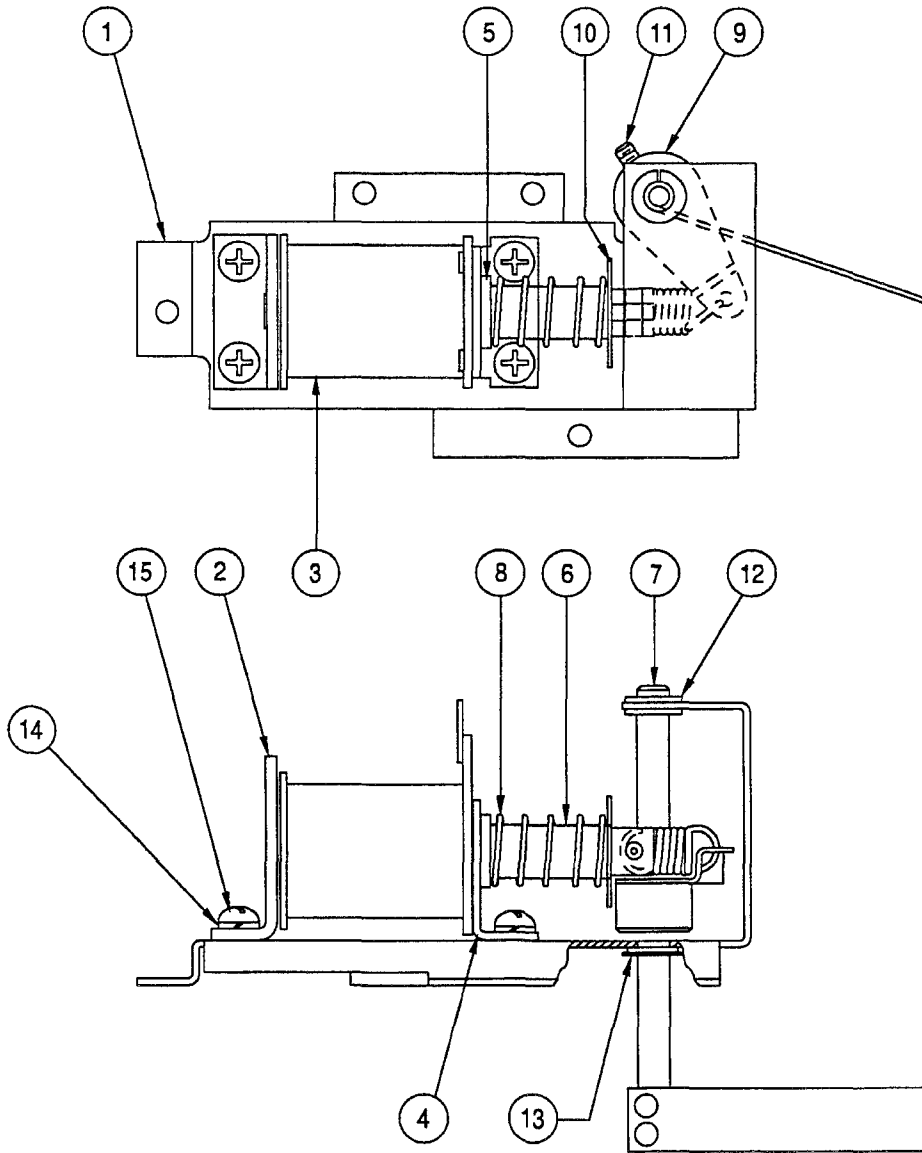

<u>Item</u>	<u>Part Number</u>	<u>Description</u>	<u>Item</u>	<u>Part Number</u>	<u>Description</u>
1.	01-11210	Bracket, Rear Diverter	9.	A-14185	Drive Arm Assembly
2.	A-10821	Flipper Stop Bracket	10.	20-8712-43	"E" Ring, 7/16" Shaft
3.	AE-26-1500	Coil Assembly	11.	4010-01082-04	Set Screw, 10-32 x 1/4" SH
4.	01-8413	Mounting Coil Bracket	12.	20-8790	Nyliner Bearing
5.	03-7066	Coil Tubing	13.	20-8712-25	"E" Ring, 1/4" Shaft
6.	A-13278	Plunger Assembly	14.	4701-00004-00	Lockwasher, #10 Split
7.	A-16316	Diverter & Shaft Assembly	15.	4010-01008-06	Mach. Screw, 10-32 x 3/8" P-PH
8.	10-135	Spring			

A-16338 Shooter Diverter Assembly

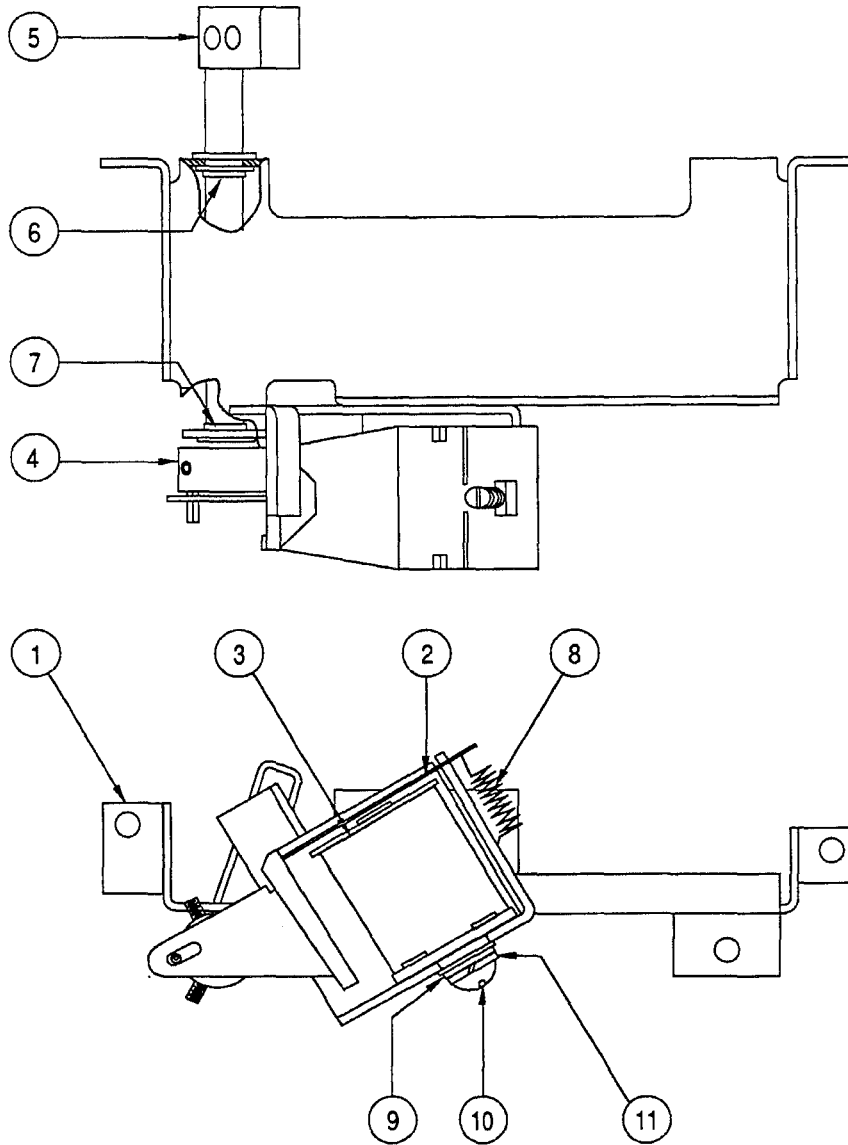

<u>Item</u>	<u>Part Number</u>	<u>Description</u>
1.	A-16459	Bracket, Shooter Diverter
2.	A-11516	Armature Assembly
3.	SZ-34-3500	Coil Assembly
4.	A-9574	Hub & Screw Assembly
5.	A-16339	Diverter & Shaft Assembly
6.	20-8712-25	"E" Ring, 1/4" Shaft
7.	20-8790	Nyliner Bearing
8.	10-96	Spring
9.	4700-00089-00	Flatwasher, 11/64 x 7/16 x 16ga.
10.	4008-01021-07	Mach. screw, 8-32 x 7/16 P-RH-BR
11.	4701-00003-00	Lockwasher #8 Split

A-16132 Gumball Machine Assembly

<u>Item</u>	<u>Part Number</u>	<u>Description</u>
1.	03-8813	Base, Front
2.	03-8814	Base, Rear
3.	03-8816	Globe, Front
4.	03-8817	Globe, Rear
5.	03-8821	Cap
6.	02-4718	Shaft
7.	03-8818	Separator
8.	03-8820	Gear, Driven
9.	03-8819	Handle
10.	03-8815	Bearing
11.	03-8847	Drive Adapter
12.	03-8475	Wheel, Geneva
13.	03-8476	Wheel, Drive
14.	01-11073	Bracket, Motor & Drive
15.	14-7984	Motor, 12V
16.	4106-01013-06	SMS #6 x 3/8 P-PH Type 25 (5 used)
17.	4700-00090-00	Flatwasher #6
18.	5647-12693-08	Sub-Miniature Switch
19.	4002-01105-07	MS, 2-56 x 7/16 P-PH SEMS (2 used)
20.	01-8240	Nut Plate, 2-56
21.	20-8712-25	"E"-Ring, 1/4" Shaft (3 used)
22.	4106-01013-10	SMS #6 x 5/8 P-PH Type 25 (2 used)
23.	H-16616	Cable, Gumball Motor
24.	4008-01017-10	MS, 8-32 x 5/8 PH-RH SEMS (4 used)
25.	4700-00091-00	Flatwasher, 11/32 x 7/8d x 15ga.

Not Shown:

26.	03-8887	Blade Guide
27.	H-16610	Cable, Gumball Switch
28.	5070-09054-00	Diode, 1N4004

A-16132 Gumball Machine Assembly

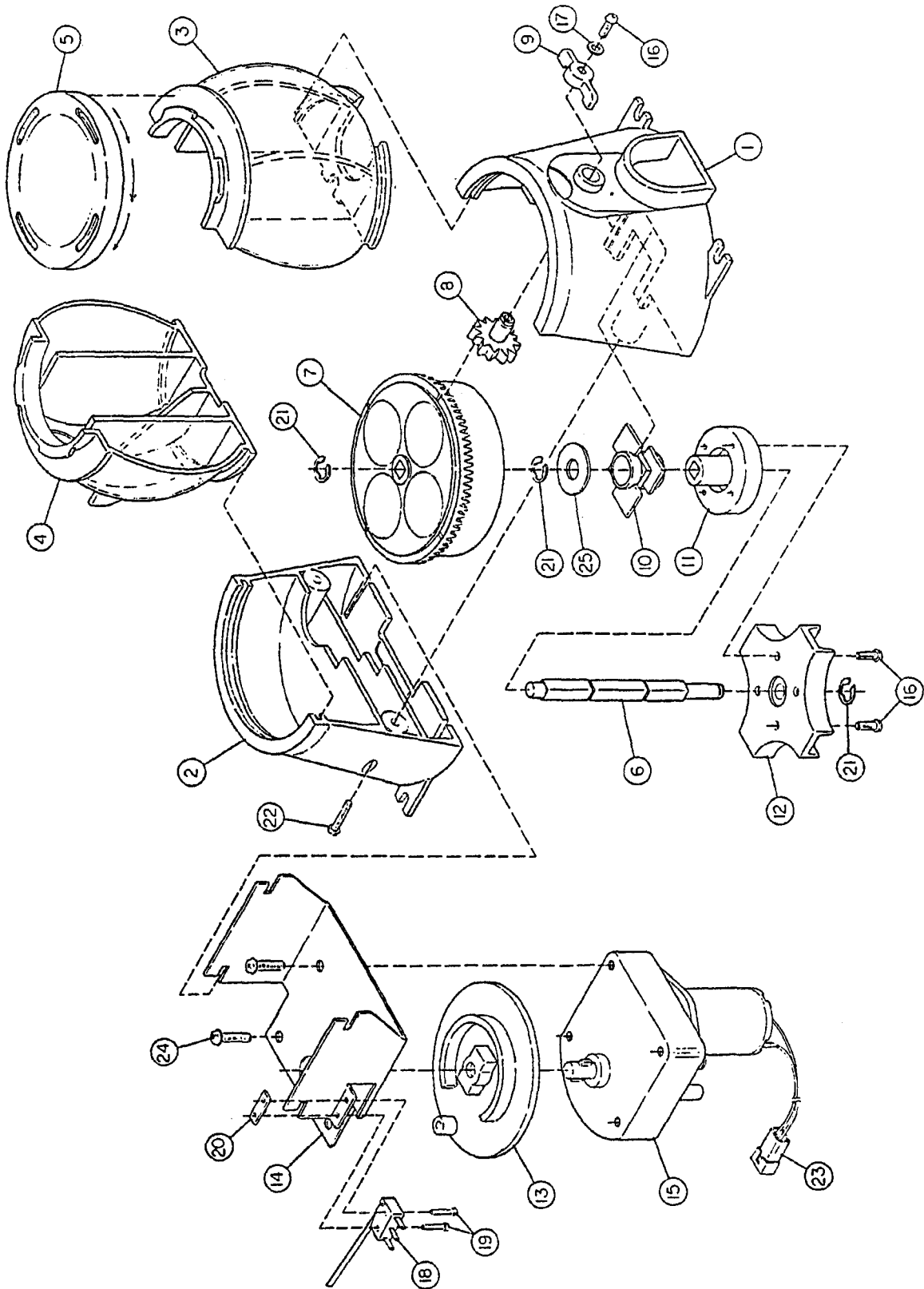

A-16124 Clock Assembly

<u>Item</u>	<u>Part Number</u>	<u>Description</u>
1.	03-8833	Housing
2.	03-8834	Back Panel
3.	03-8835	Face Plate
4.	03-8836	Lens
5.	03-8837	Minute Hand
6.	03-8838	Hour Hand
7.	03-8807	Cluster Gear, 48/52 - 32/11
8.	03-8808	Cluster Gear, 32/32 - 32/11
9.	03-8822	Cluster Gear, 32/38 -32/15
10.	03-8823	Cluster Gear, 32/40 - 32/12
11.	03-8824	Output Gear, 32/45 -32/12
12.	A-16363	PCB Clock Assembly
13.	A-16653	Shaft & Roll Pin Assembly
14.	02-4715	Gear Shaft, 1.06" (4 used)
15.	A-16652	Motor & Pinion Assembly
16.	02-4714	Drive Pin, 1 x 1/16"
17.	20-8712-15	"E"-Ring, 5/32 dia. (8 used)
18.	20-8712-18	"E"-Ring, 3/16 dia.
19.	4106-01013-28	SMS #6 x 1-3/4 P-PH (4 used)
20.	4106-01013-18	SMS #6 x 1-1/8 P-PH (4 used)
21.	Not Used	
22.	4004-01005-04	Mach. Screw, 4-40 x 1/4 P-PH
23.	Not Used	
24.	01-11337	Clock Mounting Bracket
25.	A-12887	Socket & Bulb Assembly
26.	4006-01003-04	Mach. Screw, 6-32 x 1/4 P-PH-SEMS
27.	03-8063-4	Light Bulb Sleeve - Red
28.	4700-00021-00	Flatwasher. 13/64 x 7/16 x 21 ga.
29.	03-8063-6	Light Bulb Sleeve - Yellow
30.	H-16600	Clock Cable
31.	5070-09054-00	Diode, 1N4004, 1.0A.
32.	RM-21-03	Clear Tubing
* 33.	31-1751-3	Decal
34.	01-11595	Bracket, Clock Ball Trap
35.	20-9682-1	Cap, Protective

* Not available for individual sale. Order Decal Set 31-1751.

A-16124 Clock Assembly

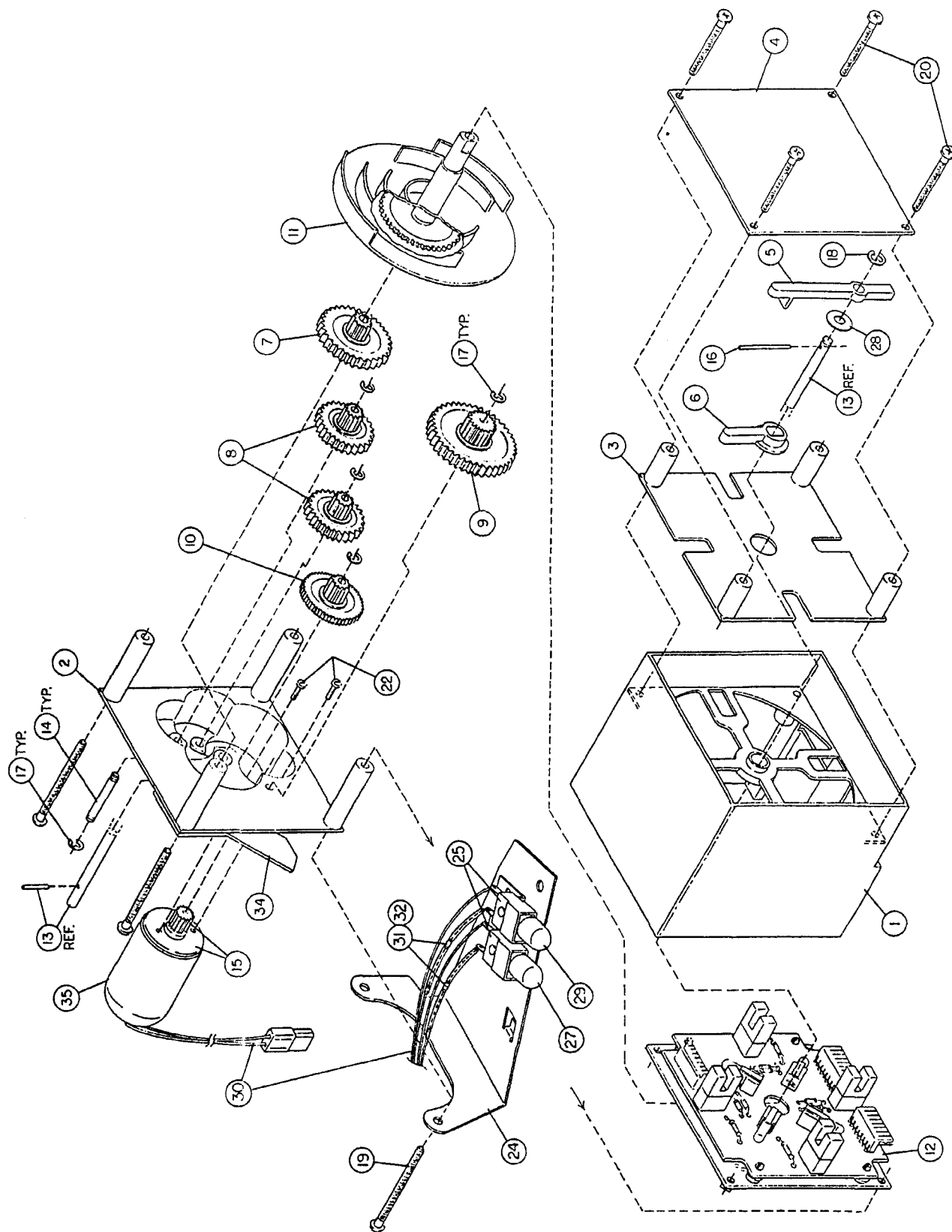

A-16307 Eject Assembly

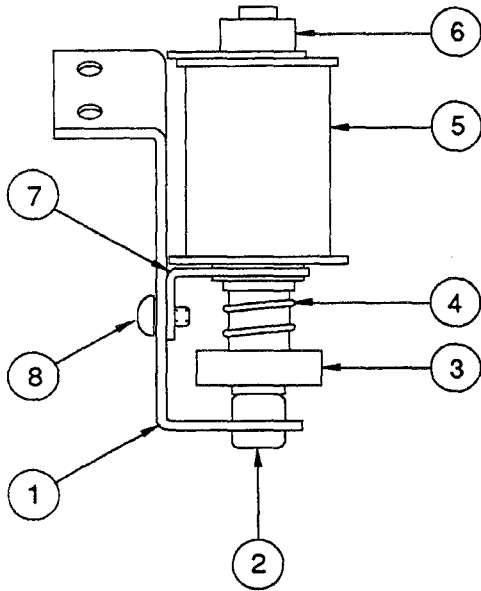

<u>Item</u>	<u>Part Number</u>	<u>Description</u>
1.	01-11205	Bracket, Eject
2.	23-6420	Rubber Grommet
3.	A-15371	Plunger Assembly
4.	10-135	Spring
5.	AE-27-1200	Coil Sub-Assembly
6.	03-7067-5	Coil Tubing
7.	01-8-508-T	Solenoid Bracket
8.	4008-01017-04	Mach. Screw, 8-32 x 1/4 P-RH-S

B-10686-1 Knocker Assembly

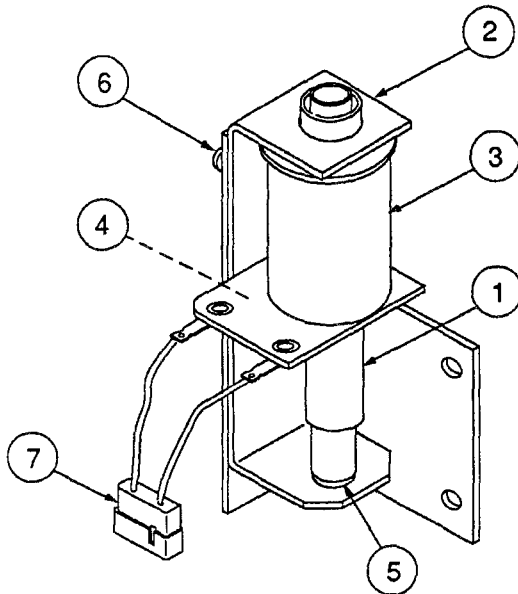

<u>Item</u>	<u>Part Number</u>	<u>Description</u>
1.	A-5387	Coil Plunger Assembly
2.	01-11273	Mtg. Bracket Assembly
3.	AE-23-800	Coil Sub-Assembly
4.	01-8-508-T	Coil Retaining Bracket
5.	23-6420	Rubber Grommet
6.	4008-01017-04	Mach. Screw, 8/32 x 1/4"
7.	H-11835	Knocker Cable
8.	03-7067-5	Coil Tubing

A-16434 Kicker Assembly

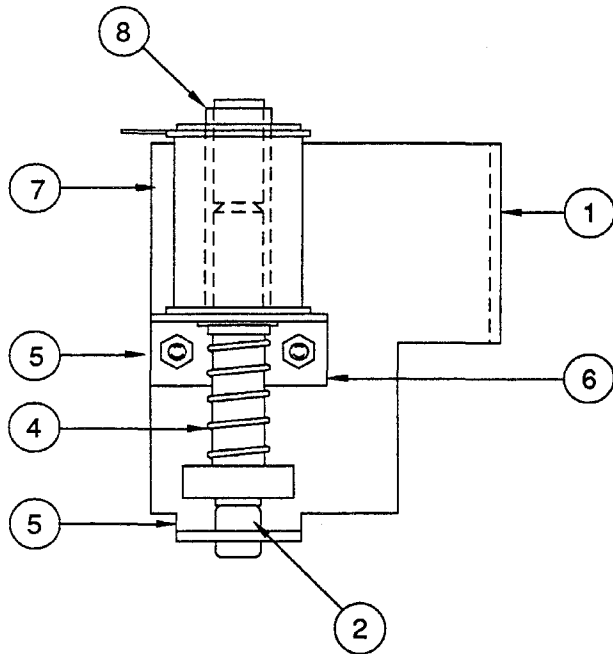

<u>Item</u>	<u>Part Number</u>	<u>Description</u>
1.	A-16435	Kicker Bracket
2.	23-6420	Rubber Grommet
3.	A-13270	Bell Armature Assembly
4.	10-135	Spring Coil Plunger
5.	4408-01119-00	Nut, 8-32 ESN
6.	01-9423	Coil Bracket
7.	AE-25-1000	Coil Sub-Assembly
8.	03-7067	Coil Tubing

Coil Magnet & Bracket Assemblies

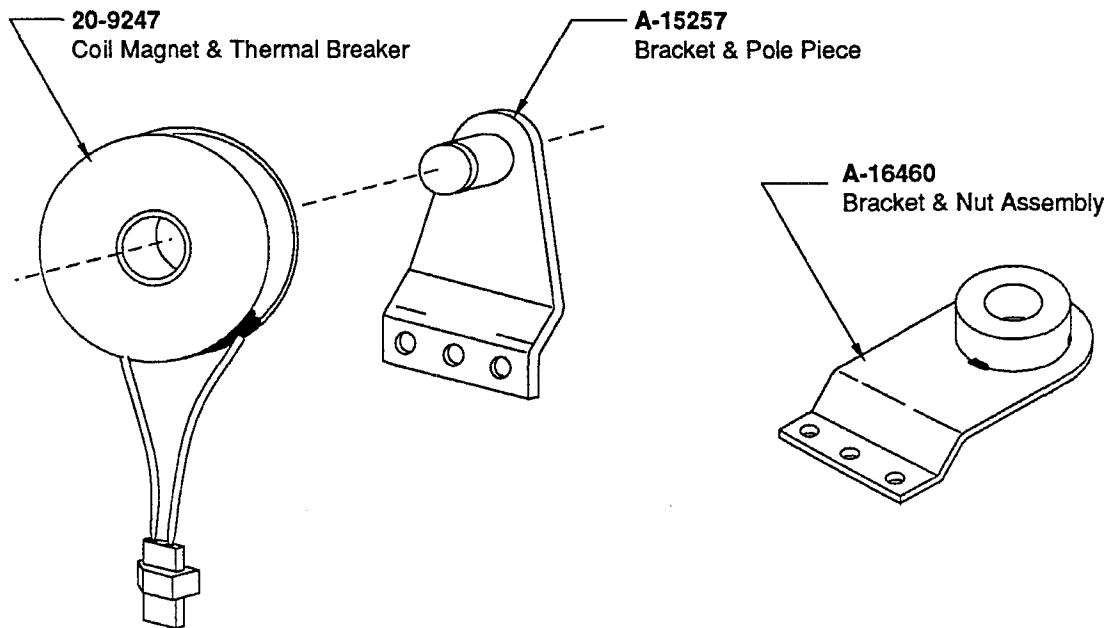

A-16713 Kicker Assembly V-Pad

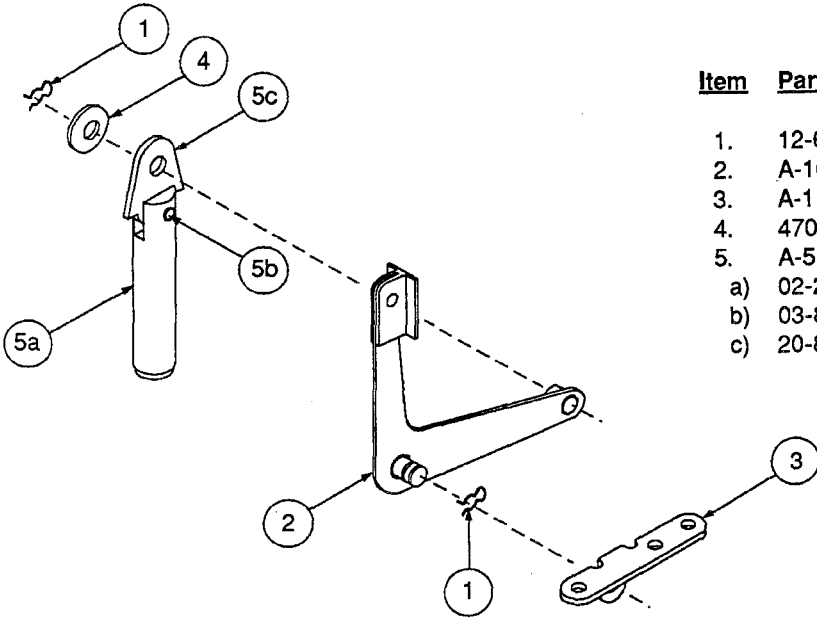

<u>Item</u>	<u>Part Number</u>	<u>Description</u>
1.	12-6227	Hairpin Clip
2.	A-16714	V-Pad Crank Assembly
3.	A-11396	Mounting Bracket Assembly
4.	4700-00030-00	Flatwasher, 17/64 x 1/2 x 15ga.
5.	A-5103	Coil Plunger Assembly
a)	02-2364	Coil Plunger
b)	03-8085	Armature Link
c)	20-8716-5	Roll Pin, 1/8 x 7/16"

A-16647 Coil & Bracket Assembly

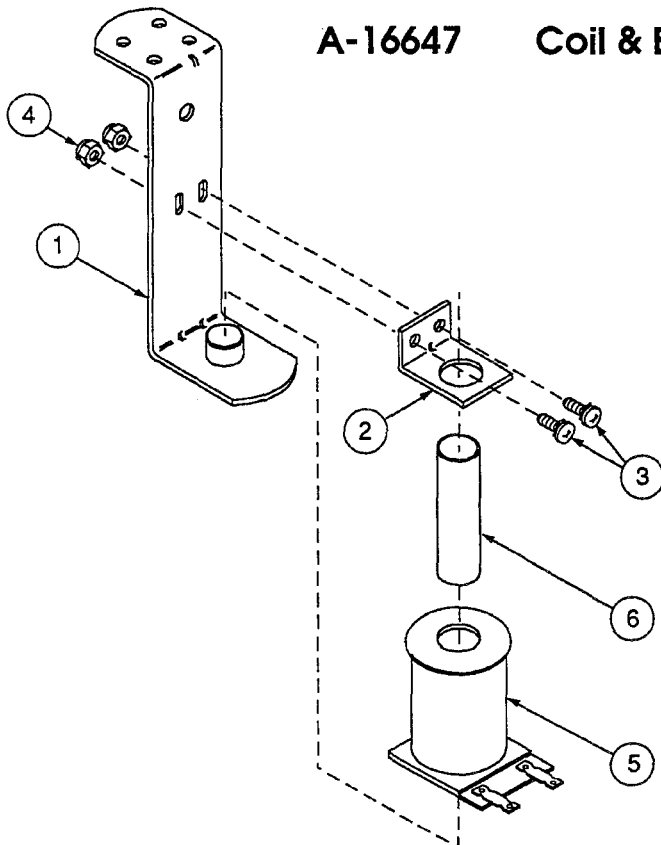

<u>Item</u>	<u>Part Number</u>	<u>Description</u>
1.	B-7572-1	Bracket & Stop Assembly
2.	01-8-508-S	Coil Retaining Bracket
3.	4006-01017-06	Mach. Screw, 6-32 x 3/8"
4.	4406-01119-00	Nut, 6-32 ESN
5.	AL-23-800	Coil Assembly
6.	03-7066	Coil Tubing

B-12445-6 Ball Shooter Assembly

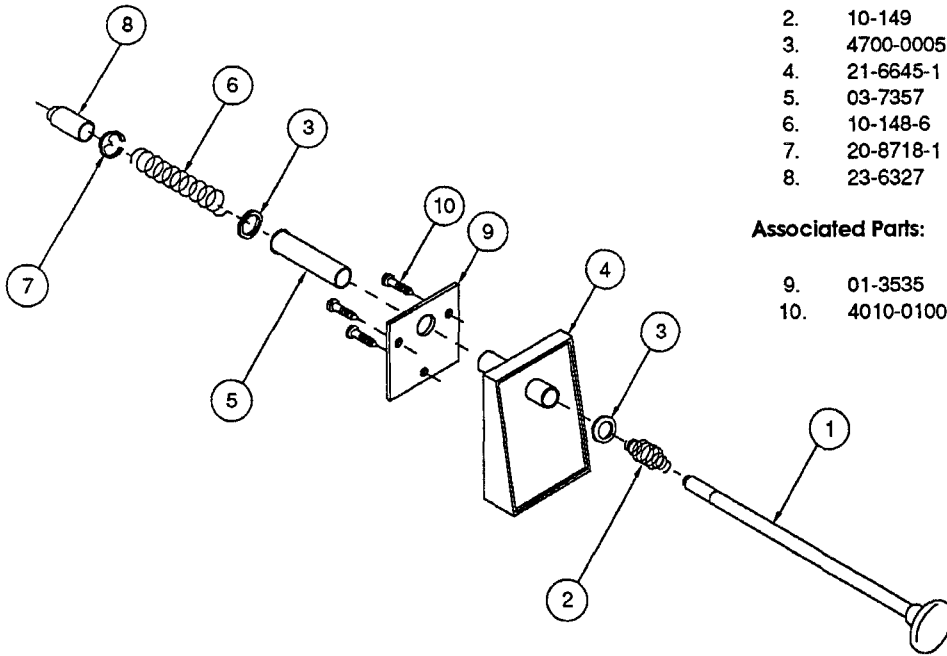

Item	Part Number	Description
1.	20-9253-7	Rod Assembly
2.	10-149	Rod Spring
3.	4700-00051-00	Flatwasher, 25/64 x 5/8 x 16ga.
4.	21-6645-1	Ball Shooter Housing
5.	03-7357	Shooter Sleeve
6.	10-148-6	Shooter Spring
7.	20-8718-1	"C" Retaining Ring
8.	23-6327	Rubber Shooter Tip

Associated Parts:

9.	01-3535	Mounting Plate
10.	4010-01006-10	Mach. Screw, #10-32 x 5/8

C-11615 Switch & Plate Assembly

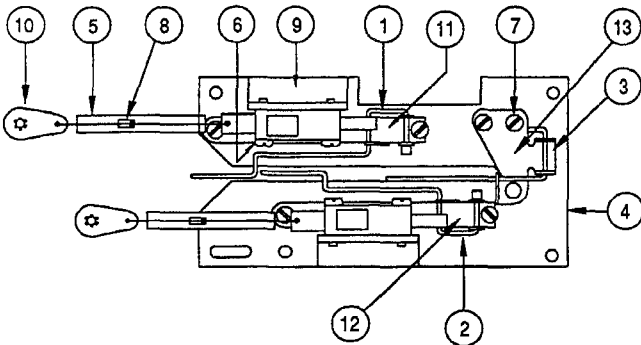

Item	Part Number	Description
1.	12-6546	Wire Form
2.	12-6547	Wire Form
3.	12-6747	Wire Form
4.	B-11616	Bracket & Mtg. Plate Assy.
5.	RM-21-03	Coil Tubing
6.	4004-01003-10	MS 4-40 x 5/8" Long
7.	4005-01005-02	MS 5-40 x 1/8 Long
8.	5070-09054-00	Diode 1N40004
9.	5647-09957-00	Micro Switch
10.	5825-09372-00	Solder Lug
11.	01-60-A	Switch Bracket
12.	01-60-F	Switch Bracket
13.	01-3411	Switch Bracket

A-15361 Tilt Mechanism Assembly

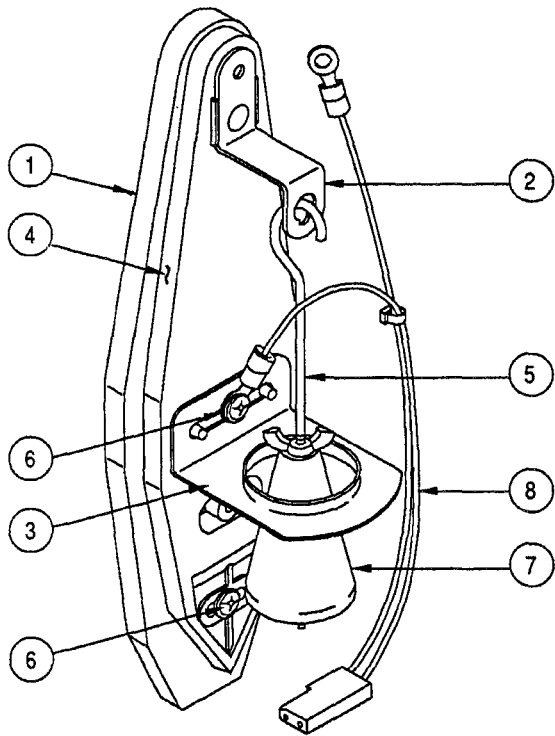

Item	Part Number	Description
1.	A-15360	Mount Plate, Tilt Mech.
2.	01-3444	Bracket, Tilt Upper
3.	01-3445	Bracket, Tilt Lower
4.	03-8668	Pendulum, Tilt Mech.
5.	12-6331	Wire, Plum Bob
6.	4006-01027-06	MS, 6-32 x 3/8 PH-WHD

Associated Parts

7.	20-6502-A	Plum Bob
8.	H-15478	Cable

A-16748 3-Bank Target Assembly

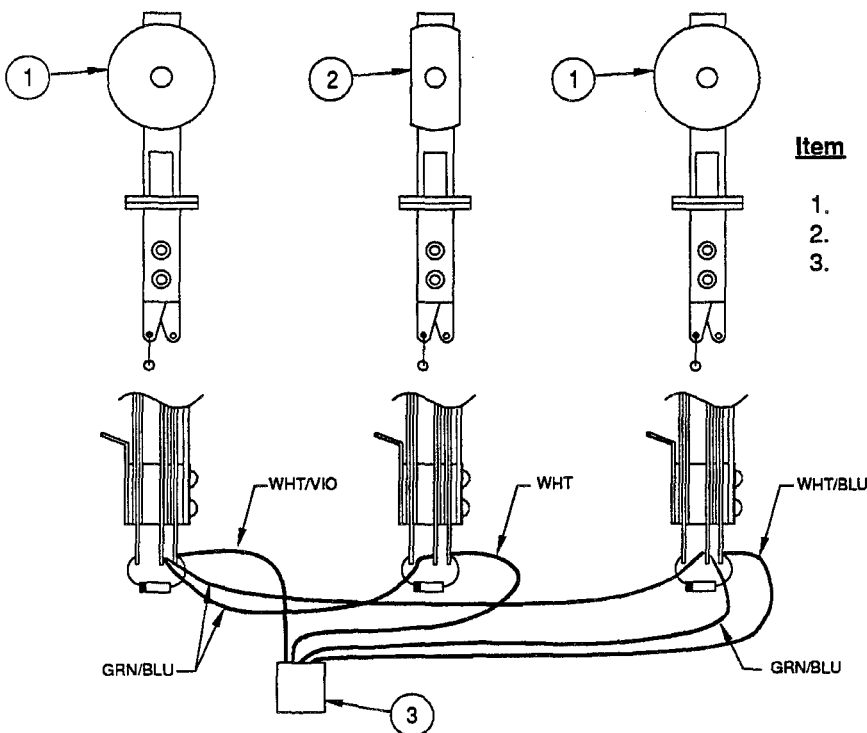

Item	Part Number	Description
1.	A-14691-6	Stationary Target Assy.
2.	A-15658-6	Oblong Standup Target
3.	H-16740	Cable Assembly

B-9414-3 Jet Bumper Assembly

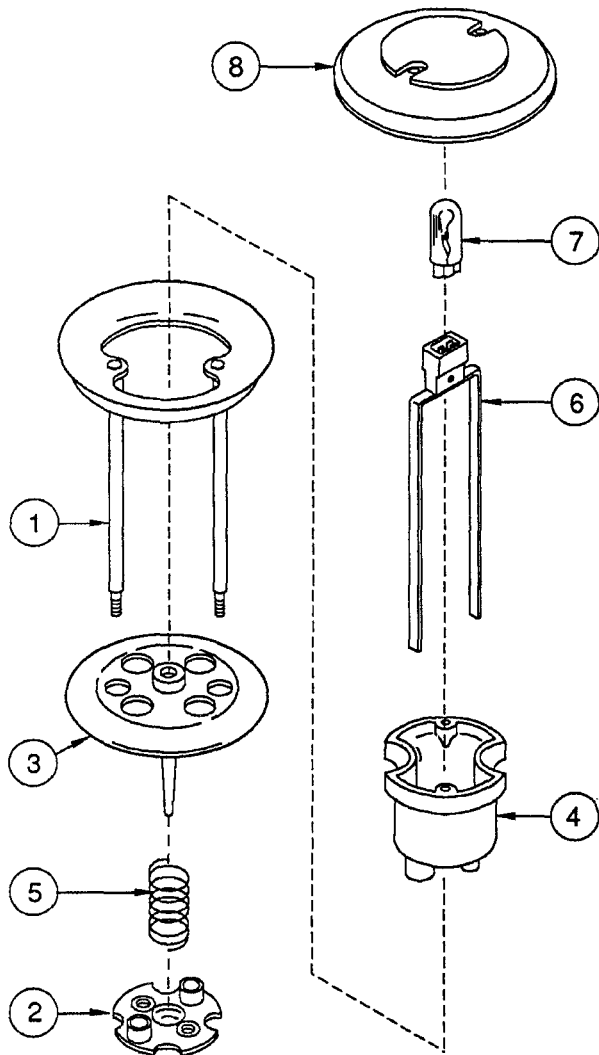

A-9415-2 Jet Bumper Coil Assembly

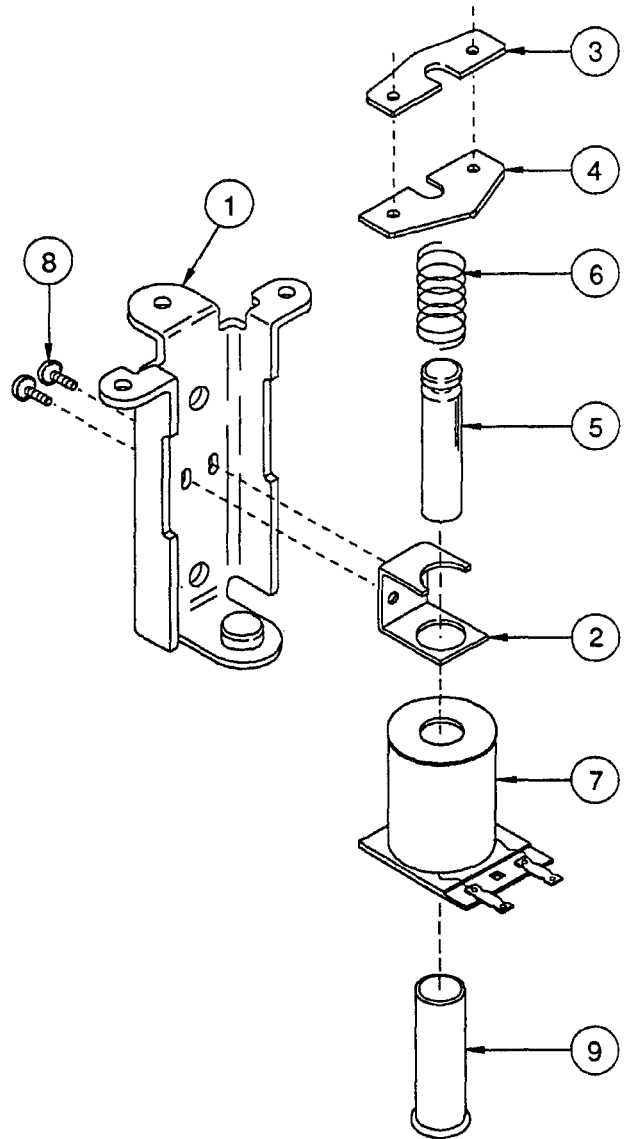

<u>Item</u>	<u>Part Number</u>	<u>Description</u>
1.	A-4754	Bumper Ring Assembly
2.	03-6009-A5	Bumper Base, White
3.	03-6035-4	Bumper Wafer, Red
4.	03-7443-5	Bumper Body, White
5.	10-7	Spring
6.	24-8776	Socket - Wedge Base
7.	24-8768	Bulb #555 (6.3V., 0.25A.)

Associated Parts:

8.	03-8254-8	Jet Bumper Cap (Tr. Amber)
	03-8254-9	Jet Bumper Cap (Tr. Red)
	03-8254-16	Jet Bumper Cap (Tr. Yellow)

<u>Item</u>	<u>Part Number</u>	<u>Description</u>
1.	B-7417	Bracket & Stop Assembly
2.	01-1747	Coil Retaining Bracket
3.	01-5492	Armature Link, Steel
4.	01-5493	Armature Link, Bakelite
5.	02-3406-1	Coil Plunger
6.	10-326	Armature Spring
7.	AE-26-1200	Coil Assembly
8.	4006-01017-04	Mach. Screw, 6-32 x 1/4"
9.	03-7066	Coil Tubing

A-16806 Mini-Playfield Assembly

<u>Item</u>	<u>Part Number</u>	<u>Description</u>
1.	36-50020-1	Mini-Playfield
2.	A-16332	Street Light Assembly
3.	A-16519	Ball Guide & Switch Assembly
4.	H-16508	Flasher Cable
5.	A-16518	Ball Guide Assembly
6.	A-16416-1	Switch Bracket Assembly
7.	A-16416-2	Switch Bracket Assembly
8.	A-16416-3	Switch Bracket Assembly
9.	A-16326	Ball Guide Assembly
10.	A-12887	Socket Assembly, #555 Bulb
11.	A-12753-2	Lug & Diode Assembly
12.	A-12336-1	Socket & Bulb Assembly
13.	A-15257	Bracket & Pole Piece Assembly
14.	20-9247-1	Magnet & Pin Assembly
15.	01-11524	Mini-Playfield Protector
16.	01-11217	Ball Guide
17.	02-4425-1	Post 8-32/8-32 x 5/8"
18.	02-4660	Post Single Bumper #10
19.	02-4426-1	Post #8WS 6-32 Top
20.	02-4426-2	Post #8WS 6-32 Top
21.	03-8319-13	Post #8 Starred Clear
22.	03-7655-4	Cable Clamp, 1/4"
23.	03-7655-8	Cable Clamp, 1/2"
24.	03-8371	Spacer Spool #8
25.	03-8022-1	Spacer, .550 L.
26.	03-6047	Spacer, 9/16"
27.	20-9247	Coil Magnet
28.	20-9672	Cover Switch Protector
29.	23-6305	Rubber Ring, 2" I.D.
30.	23-6303	Rubber Ring, 1-1/4" I.D.
31.	23-6535	Rubber Bumper
32.	A-16651-9	Playfield Plastic Assembly
33.	31-1765-32	Playfield Plastic
34.	31-1765-33	Playfield Plastic
35.	RM-21-03	Tubing #10
36.	H-16502	Mini-Playfield Cable
37.	H-16603	Mini-Playfield Opto Cable
38.	4408-01118-00	Nut 8-32 Tee x 3/8
39.	4106-01115-06Y	Sh. Metal Screw, #6 x 3/8 PL-HWH-YEL
40.	4008-01005-32	Mach. Screw, 8-32 x 2 P-PH
41.	4106-01114-08	TCS 6 x 1/2 PLHWH-17
42.	4408-01119-01	Nut 8-32 ESNA
43.	4008-01005-28	Mach. Screw, 8-32 x 1-3/4P-PH
44.	4410-01132-01	Nut, 10-32 ESNA
45.	4700-00021-00	Flatwasher, 13/64 x 7/16 x 21ga.
46.	4406-01119-00	Nut 6-32 ESN
47.	4106-01115-16	Sh. Metal Screw, 6 x 1" HWH
48.	4106-01013-10	Sh. Metal Screw, 6 x 5/8 P-PH
49.	03-8063-6	Sleeve, Yellow
50.	5070-09034-00	Diode, 1N4004
51.	20-9860	Cover Switch Protect

A-16806 Mini-Playfield Assembly

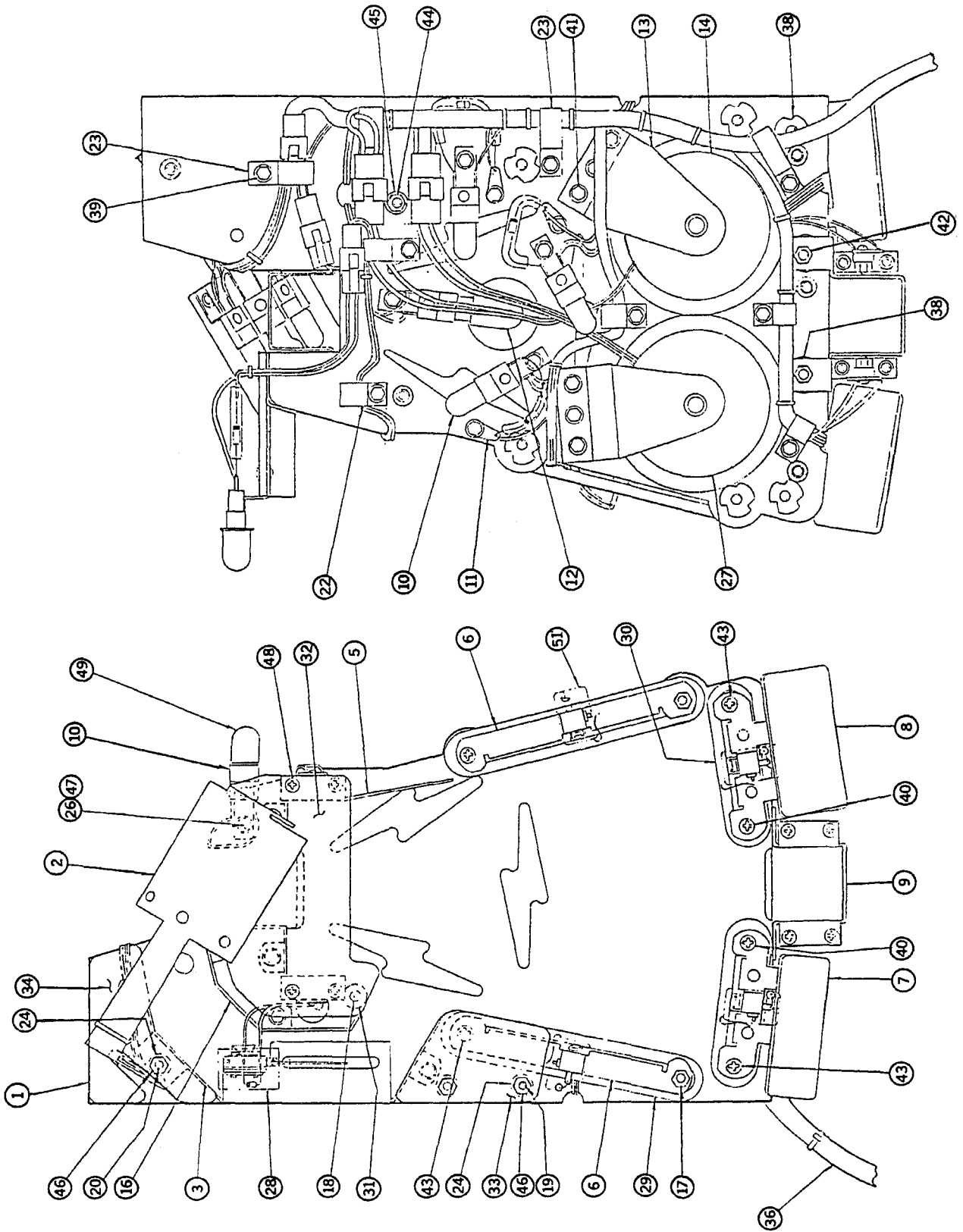

BACK VIEW

FRONT VIEW

Coin Door Assembly

A-14148-1 U.S.A. Door with Decals

09-17002-x 2-Chute Door
 09-17003-x 3-Chute Door
 ("x" is the country designator)

<u>Item</u>	<u>Part No.</u>	<u>Description</u>	<u>Quantity</u>
1	27-1038	Button Cover	2 or 3
2	27-1041-1 58	Price Panel	2 or 3
3	27-1026-1 17	Coin Entry Plate	2 or 3
4	27-1016	Lock Assembly	1
5	27-1061-1	Coin Return - Bezel	1
6	27-1062	Coin Return Flap	1
7	27-1021	Button Housing - 2-slot	1
	27-1022	Button Housing - 3-slot	1
8	27-1111	Interlock Switch	1
9	27-1006-1	Coin Door , 2-Slot	1
	27-1007-1	Coin Door , 3-Slot	1
10	27-1005	Coin Door Frame	1
11	27-1003	M/C Screw, 6-32 x 3/16	4
12	5641-12724-00	Diagnostic Switch	1
13	27-1101	M/C Screw, 4-40 x 1/4	2
14	01-9885	Bracket, Diagnostic Switch	1
15	27-1037	Plastic Button	1
16	27-1078	M/C Screw, 6-32 x 3/8	2 or 3
17	27-1039	Conical Spring	2 or 3
18	27-1079	Self-tapping Screw, #6 x 1/4	2
19	27-1077-1	Coinbox Cover	1
20	27-1066	Slam Switch	1
21	27-1067	M/C Screw, 4-40 x 1/2	2
22	27-1017	Nut (key)	1
23	27-1012	Locking Cam	1
24	27-1011	Locking Arm	2
25	27-1020	Washer	1
26	27-1018	Star Washer	1
27	27-1019	M/C Screw, 1/4-28 x 5/16	1
28	27-1089	R-Ring	1
29	27-1083	Retainer	1
30	27-1081	Coin Inlet Chute	2 or 3
31	27-1088	Cable Clamp	2 or 3
32	27-1025	Key Hook	1
33	27-1086	Washer, #6	2 or 3
34	27-1078	M/C Screw, 6-32 x 3/8	1 or 2
	27-1113	M/C Screw, 6-32 x 7/16	1
35	27-1079	Self-tapping Screw, #6 x 1/4	2 or 3
36	27-1084	Lamp Socket	2 or 3
	27-1085	Lamp	2 or 3
37	27-1096	Self-tapping Screw, #5 x 3/8	2 or 3
38	27-1087	M/C Screw, 6-32 x 5/8	2 or 3
39	27-1082	Lever Arm	2 or 3
40	27-1097	Switch Cover	2 or 3
41	27-1091-1	Coin Accept Chute	2 or 3
42	27-1075	Wire Form (Small)	2 or 3
	or		
	27-1093	Wire Form (Large)	
43	27-1094	M/C Screw, 4-40 x 7/8	4 or 6
44	27-1087	M/C Screw, 6-32 x 5/8	4 or 6
45	27-1086	Washer, #6	4 or 6
46	27-1095	Nut, 4-40 ESNA	4 or 6
47	27-1076-1	Coin Return Box	1
48	27-1078	M/C Screw, 6-32 x 3/8	2
49	27-1092	Microswitch	2 or 3

Coin Door Assembly

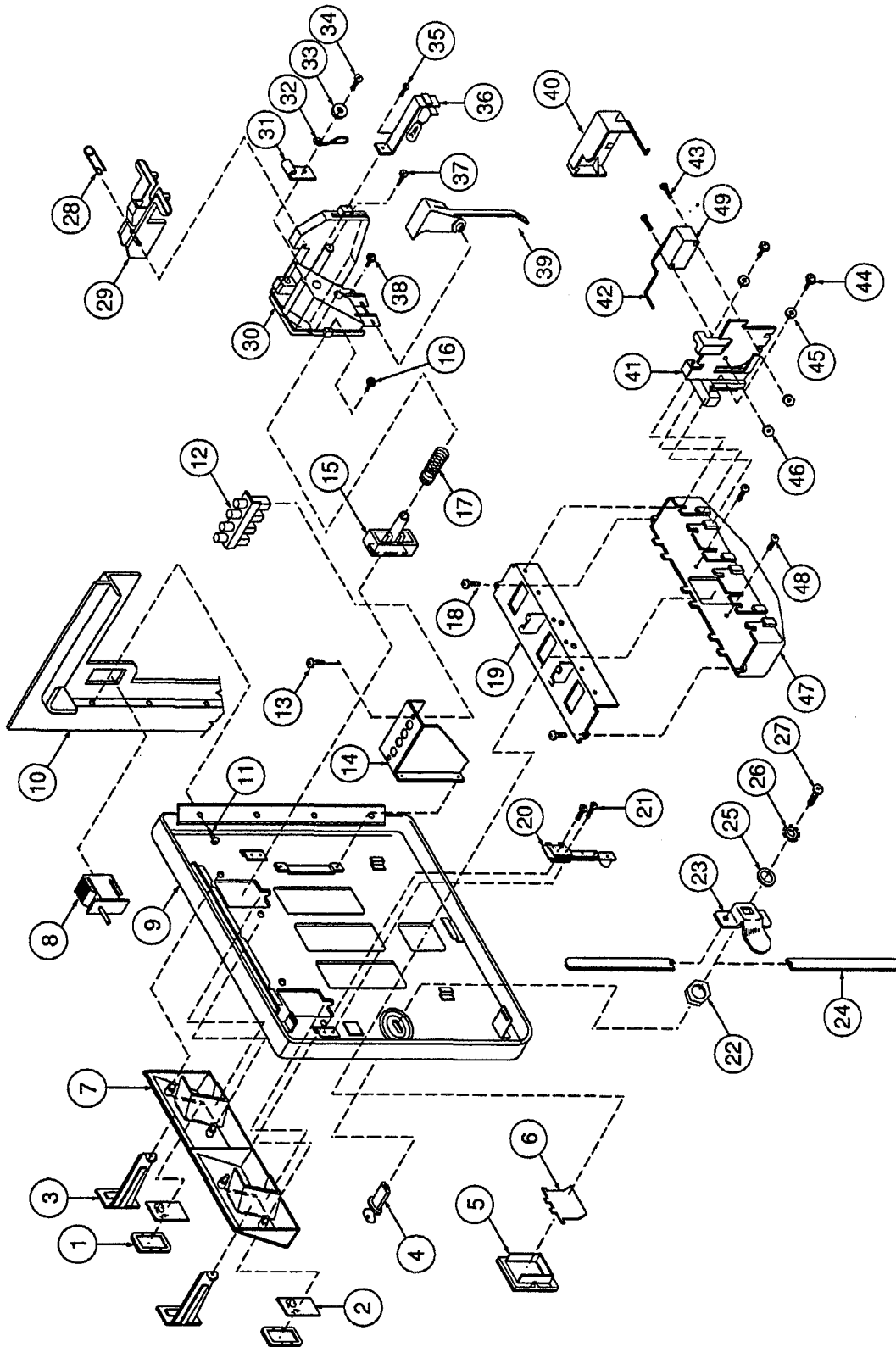

Unique Parts List

<u>Part Number</u>	<u>Description</u>	<u>Part Number</u>	<u>Description</u>
A-12742-50020	WPC CPU Board	A-16379	3-Switch & Bracket Assembly
A-13204-50020	Bottom Arch Assembly	A-16381	Loop Assembly
A-13769-50020	Playfield & Insert Assembly	A-16391	Ball Guide Assembly
A-13769A-50020	Mini-Playfield & Insert Assy.	A-16416-1	Mini-Playfield Sw. & Brkt. Assy.
A-14375-2	Coil & Bracket Assembly	A-16416-2	Mini-Playfield Sw. & Brkt. Assy.
A-15896-2	Sw. Button & Cable Assembly	A-16433	Shooter Gate Assembly
A-12738-50020	Sound Board Assembly	A-16434	Kicker Assembly
A-16055	Front Molding Assembly	A-16495	Transformer Mtg. Plate Assembly
A-16056	Right Wire Chute Assembly	A-16514-1	4-Lamp Board Assembly
A-16058	Mini Inside Wire Chute Assy.	A-16515-1	3-Lamp Board Assembly
A-16059	X-Over Wire Chute Assembly	A-16516-1	3-Lamp Board & Spacer Assy.
A-16060	Main Ramp Assembly	A-16517-1	3-Lamp Board & Spacer Assy.
A-16062	Center Ramp Assembly	A-16518	Ball Guide Opto Assembly
A-16063	Right Diverter Brkt. Assembly	A-16519	Ball Guide & Switch Assy.
A-16064	Right Diverter Assembly	A-16520	Switch & Bracket Assembly
A-16100-1	8-Driver PCB & Spacer Assy.	A-16528	Trough-Coil Assembly
A-16114	Diverter Assembly	A-16533	Ball Sensor Assembly
A-16116-1	8-High Pwr Driver & Spacer Assy.	A-16534-1	Prox Opto Sensor & Spacer Assy.
A-16117-1	Cashbox Assembly	A-16535	Ramp Prox Opto Sensor Assy.
A-16119	Right Deflector Assembly	A-16536	Opto & Plate Assembly
A-16120-1	D.C. Motor Control & Spacer Assy.	A-8552-50020	Backglass Assembly
A-16123	Backbox Assembly	A-16806	Mini-Playfield Assembly
A-16124	Clock Assembly		
A-16132	Gumball Machine Assembly	B-12445-6	Ball Shooter Assembly
A-16133	Main Chute Assembly		
A-16164	Lock Up Ramp Assembly	01-11063	Deflector - Center
A-16170	Lock Up Trough Assembly	01-11064	Deflector - Left
A-16174	Shooter Ramp Assembly	01-11065	Deflector - Right
A-16181	Ball Guide Assembly	01-11067	Deflector - Flipper
A-16182	Ball Guide Assembly	01-11162-1	Flipper Ball Guide - Right
A-16184	Ball Guide Assembly	01-11162-2	Flipper Ball Guide - Left
A-16185	Ball Guide Assembly	01-11216	Ball Guide, Mini-Playfield
A-16186	Ball Guide Assembly	01-11217	Ball Guide, Mini-Playfield
A-16188	Ball Guide & Opto Assembly	01-11218	Ball Guide, Mini-Playfield
A-16189	Ball Guide Assembly	01-11219	Ball Guide, Shooter
A-16190	Ball Guide & Opto Assembly		
A-16201	Ball Guide Assembly	02-4436-25	F-F Spacer, 8-32 x 1-9/16"
A-16202	Ball Guide Assembly	02-4611-2	Post M-F 8-32 x 1.69 Hex.
A-16203-1	Flipper Ball Guide Assy., Right	02-4611-3	Post M-F 8-32 x 2.12 Hex.
A-16203-2	Flipper Ball Guide Assy., Left	02-4611-4	Post M-F 8-32 x 3.12 Hex.
A-16216	Rear Trough Assembly		
A-16233	Ball Guide Assembly	03-8870-2	Plfd. Mylar - Small
A-16287	Speaker/Display Assembly	03-8870-3	Plfd. Mylar - Small
A-16307	Eject Assembly		
A-16312	Ball Popper Assembly	08-7028-1	Playfield Glass (Wide Body)
A-16313	Rear Diverter Assembly		
A-16326	Mini-Playfield Exit Opto Assy.	11-1106	50020-Cabinet
A-16327-1	G.I. & Flash 19-Lamp Board	11-50020-IN	Wood Insert Panel
A-16328-1	6-Lamp Board & Spacer Assy.	11-831-50020	50020- Back Panel
A-16329-1	3-Lamp Board Assembly		
A-16330	2-Flash Lamp PC Board Assy.	12-7059	Wire Chute - Right
A-16338	Shooter Diverter Assembly	12-7060	Wire Chute - Mini Feed
A-16354	Auto Shooter Opto Assembly	12-7061	Wire Chute - Mini Inside
A-16361	Bridge Diverter Assembly	12-7062	Wire Chute - Cross Over







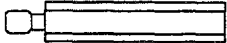
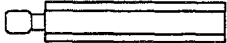
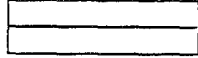
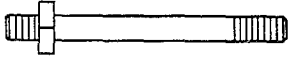

Unique Parts List (Continued)

<u>Part Number</u>	<u>Description</u>
20-9663-9	Switch Lighted P/B
20-9809	Ceramic Pinball
20-9811-1	PCB Support Post
31-1002-50020	Screened Playfield - Twilight Zone
31-1002A-50020	Screened Mini-Playfield - Twilight Zone
31-1008-50020	Screened Bottom Arch
31-1420-50020	Screened Speaker Panel Cover
31-1473	Screened Shooter Gage
31-1751-1, -2, -3	Decal - Bottom Side Ramp
31-1765-10, -11	Playfiel Plastic
36-50020	Playfield Hard Coat
36-50020-1	Mini-Playfield Hard Coat
50020-BB	Backbox Assembly - Twilight Zone
50020-IN	Insert Panel - Twilight Zone
50020-PL	Playfield - Twilight Zone

Cables List

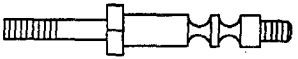
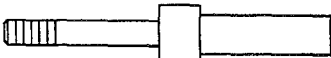
<u>Part Number</u>	<u>Description</u>
H-11835	Knocker Cable
H-13870	Black Jumper Cable
H-14584	Dot Matrix Display Cable
H-14790	A.C. Cable
H-14792-1	A.C. Jumper Cable
H-14792-2	A.C. Jumper Cable
H-15011	Speaker Panel Cable
H-15476	Logic Power Cable
H-15478	Tilt Switch Cable
H-15736	Secondary Cable
H-16497	Playfield Switch Cable
H-16499	Playfield Solenoid Cable
H-16500	Insert Cable

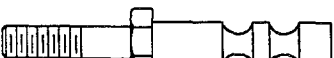
Posts

	<u>Part Number</u>	<u>Description / Quantity</u>
	02-4335-8	Mounting Post, 8-32 x 1.44" (1)
	02-4436-10	F-F Spacer, 8-32 x 2-1/2" (1)
	02-4425-1	Post 8-32/ #8-32 x 5/8" (1) Post Fastener 8-32/8-32 x 9/32" (3)
	02-4426-1	Post #6-32 /8 1-29/32" (13)
	02-4177	Bumper Post 8-32 x 15/32" (2)
	02-4434	Post, #8 x 1" (2)
	02-4658	Double Bumper Post (4)
	02-4659	Mini Post (4)
	02-4660	Single Bumper Post (9)
	02-4608	Double Bumper Post (2)
	03-8247-13	Double Star Post, Clear (8)
	03-8319-13	Star Post #8 (2)

LOWER PLAYFIELD PARTS

Item Part Number Part Number

- 1. A-16713 Metal Kicker
- A-16647 Coil & Bracket Assembly
- 2. A-16338 Shooter Diverter Assembly
- 3. C-9638 Multiball Eject Assembly
- 10-128 Spring
- A-16766 Coil & Bracket Assembly
- 4. 01-10523 Safety Bracket (2 Used)
- 5. A-15205-R-4 Lower Right Flipper Assembly
- 6. A-16328 6-Lamp Board
- 7. B-12665 Kicker Arm (Slingshot) Assy., Right
- A-16645-R Coil & Bracket Assembly
- 8. A-16713 Kicker Assembly V-Pad
- A-16647 Coil & Bracket Assembly
- 9. A-16434 Kicker Assembly
- 10. A-15205-R-3 Upper Right Flipper Assembly
- 11. A-16381 Right Deflector Assembly
- 12. A-16133 Main Chute Assembly
- 13. A-16460 Bracket & Nut Assembly (2 used)
- 14. 20-9247 Coil Magnet (2 used)
- 15. A-16737-2 Plifd. Slide Mechanism, Right
- 16. A-16307 Eject Assembly
- 17. A-16120 D.C. Motor Assembly
- 18. 01-10726 Rear Guide Leg (2 used)
- 19. A-16313 Rear Diverter Assembly
- 20. A-16312 Ball Popper Assembly
- 21. A-16216 Rear Trough Assembly
- 22. A-16807 10-Switch Opto PC Board
- 23. A-15205-L-1 Upper Left Flipper Assembly
- 24. A-16637-1 Plifd. Slide Mechanism, Left
- 25. A-9415-2 Jet Bumper Coil Assembly (3 used)
- B-12030-2 Switch & Diode Assembly (3 used)
- 26. A-16327 19-Lamp Board Assy.
- 27. B-12665 Kicker Arm (Slingshot) Assy., Left
- A-16645-L Coil & Bracket Assembly
- 28. A-15205-L-4 Lower Left Flipper Assembly
- 29. A-16116 8-High Power Driver PC Board
- 30. C-11615 Micro-Switch Plate Assembly
- 31. B-12224 Single Laamp Board
- 32. A-16119 Right Deflector
- 33. 03-8826 Small Chute Assembly
- 34. A-16514 4-Lamp Board
- 35. A-16515 3-Lamp Board
- 36. A-16132 Gumball Machine Assembly
- 37. A-16516 3-Lamp Board
- 38. A-16329 3-Lamp Board
- 39. A-16534 Prox Opto Sensor Assembly
- 40. A-16517 3-Lamp Board
- 41. A-16533 Ball Sensor Assembly

Underside of Playfield, Viewed In Raised Position

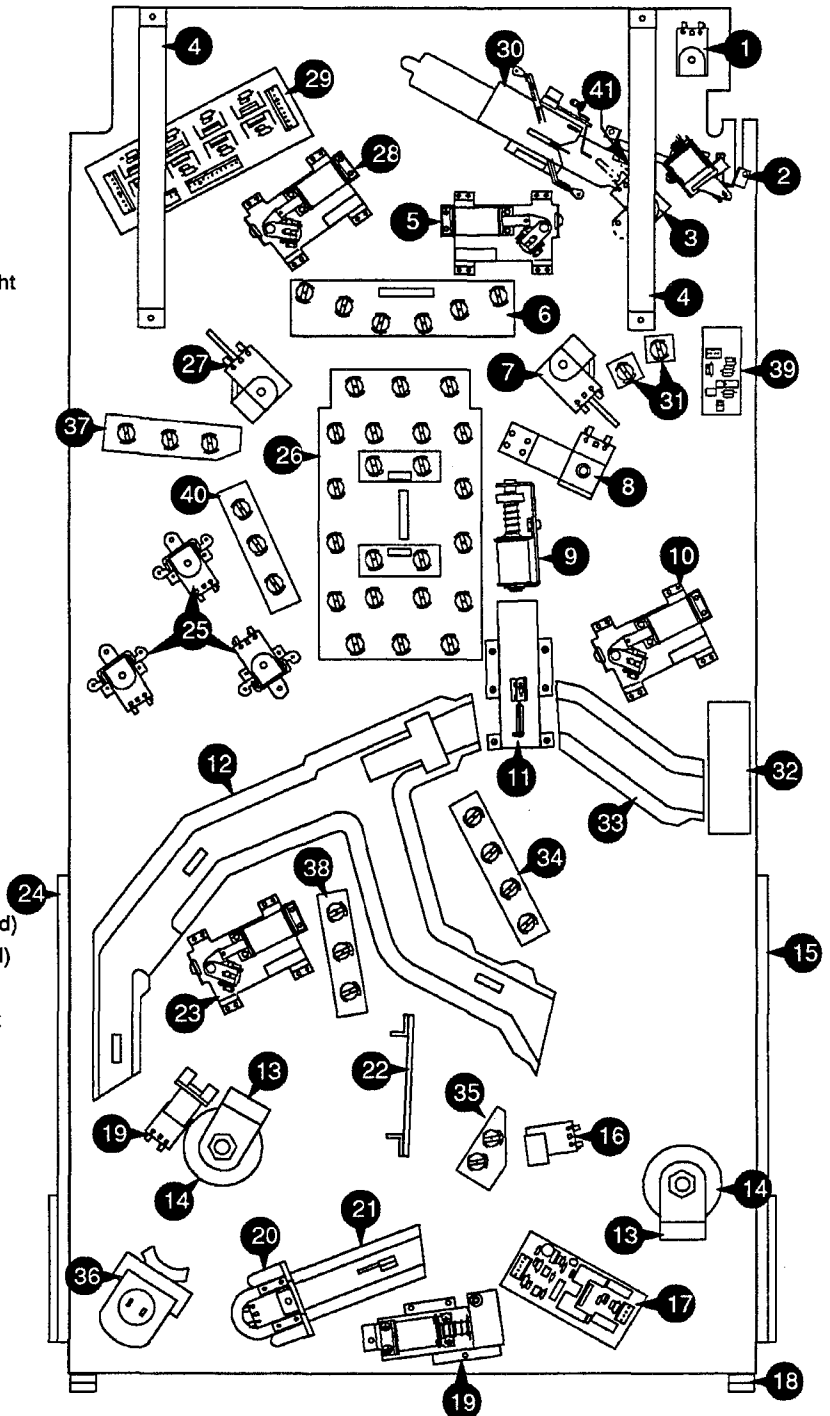

UPPER PLAYFIELD PARTS LIST

<u>Item</u>	<u>Part Number</u>	<u>Description</u>	<u>Not Shown:</u>	
1	01-11401	Playfield Hanger Brackets (2)	A-13204-50020	Bottom Arch Assembly
2	20-9250-6	Flipper & Shaft, Yellow	A-13769-50020	Screened Playfield
3	A-16203-2	Flipper Ball Guide Assy., Left	A-14632-2	Mounting Brkt. Clamp Assy. 1/2"
4	03-8318-16	Double Light Hood, Yellow	A-14632-3	Mounting Brkt. Clamp Assy. 3/4"
5	01-9510	#8 Post Adjustment Plate (2)	A-14632-4	Mounting Brkt. Clamp Assy. 1"
6	A-14691-6	Standup Target, Yellow	A-16513	Bridge Diverter Gate
7	03-8254-16	Jet Bumper Cap, Yellow	A-16651-1	Playfield Plastic Assembly
	B-9414-3	Jet Bumper Assembly	A-16651-2	Playfield Plastic Assembly
	A-12753-2	Lug & Diode Assembly	A-16651-3	Playfield Plastic Assembly
8	03-8254-9	Jet Bumper Cap, Red	A-16651-4	Playfield Plastic Assembly
	B-9414-3	Jet Bumper Assembly	A-16651-5	Playfield Plastic Assembly
	A-12753-2	Lug & Diode Assembly	A-16651-6	Playfield Plastic Assembly
9	03-8254-8	Jet Bumper Cap, Amber	A-16651-7	Playfield Plastic Assembly
	B-9414-3	Jet Bumper Assembly	A-16651-8	Playfield Plastic Assembly
	A-12753-2	Lug & Diode Assembly	A-8645	Wire Form & Bracket Assembly
10	A-16185	Ball Guide Assembly	B-8623	Runway Ball Guide w/Baffle
11	A-16186	Ball Guide Assembly	01-3569-1	Ball Return Runway
12	A-16184	Ball Guide Assembly	01-5575	Bottom Arch Mounting Brackets
13	20-9264-6	Small Flipper & Shaft, Yellow	01-10599	Runway Ball Guide, Long
14	01-11067	Flipper Deflector	01-10621	Strike Plate
15	01-11064	Left Deflector	01-11426	Mini-playfield Support Bracket
	01-11207	Impact Bracket	01-11427	Mini-playfield Inner Bracket
16	01-11151	Ball Guide	01-11428	Mini-playfield Outer Bracket
17	A-16132	Gumball Machine	01-11429	Mini-playfield Rear Bracket
18	01-11164	Ball Guide Assembly	01-11640	Ramp Guard Left
19	02-4611-4	Standoff 3 1/8"	01-11648	Ball Deflector
20	01-11186	Rear Deflector	01-11548	Ramp Guard Right
21	A-16164	Lock-up Ramp Assembly	02-4335-8	Standoff 1 7/16"
22	A-16785	Ball Guide Assembly	12-6542	Runway Gate Wire
23	A-16170	Lock-up Trough Assembly	31-1743	Shooter Gauge
24	A-12258-2	#8-32 Stud Plate Assembly	50020-Plastic	Playfield Plastic Set
25	02-4436-10	Standoff 2 1/2"		
26	A-16796	Ball Guide Assembly		
27	A-16124	Clock Assembly		
	01-11063	Center Deflector		
28	A-15658-2	Oblong Standup Target, Green		
29	A-14691-4	Standup Target, Red		
30	A-16794	Ball Guide Assembly		
31	A-16064	Right Diverter Assembly		
32	A-16119	Right Deflector Assembly		
33	02-4611-3	Standoff 2 1/8"		
34	A-16174	Shooter Ramp Assembly		
35	01-11581	Ball Guide		
36	A-15658-6	Oblong Standup Target, Yellow		
37	01-11149	Ball Guide		
38	01-11149	Ball Guide		
39	20-9250-6	Flipper & Shaft, Yellow		
40	A-16433	Shooter Gate Assembly		
41	02-4611-2	Standoff 1 11/16"		
42	A-16751	Ball Guide Assembly		
43	01-11518	Ball Guide		
44	01-11219	Ball Guide, Shooter		
45	12-6466-8	2" Wire Guide		
46	A-16203-1	Flipper Ball Guide Assy., Right		
47	20-9250-6	Flipper & Shaft, Yellow		
48	A-16851	Ball Guide Assembly		
49	A-15802-P	Level Assembly		
50	02-4611-5	Standoff 1 1/4"		
51	A-8039-3	Ball Release Assembly		

*Twilight Zone has a special hardcoat playfield and does not require a full mylar. However, mylars can be purchased through your local Bally Distributor (ref. #03-7960-50020-1).

UPPER PLAYFIELD PARTS

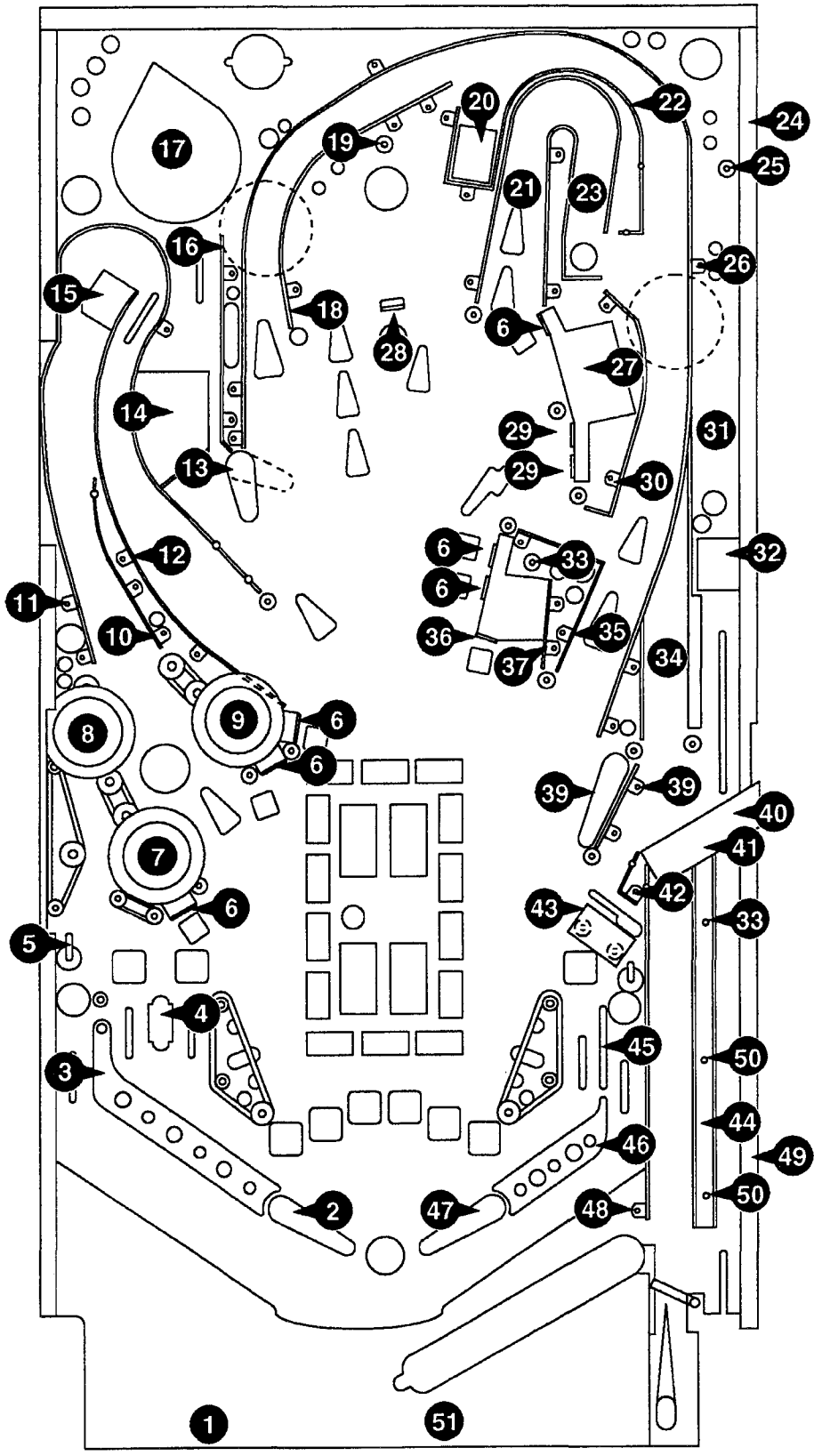

SWITCH MATRIX

Dedicated Grounded Switches	Column Row	White → ← Green									Flipper Grounded Switches
		1 Green-Brown J206-1 U20-18	2 Green-Red J206-2 U20-17	3 Green-Orange J206-3 U20-16	4 Green-Yellow J206-4 U20-15	5 Green-Black J206-5 U20-14	6 Green-Blue J206-6 U20-13	7 Green-Violet J206-7 U20-12	8 Green-Gray J206-9 U20-11	9 Gray-White * J5-1	
Orange-Brown J205-1 (1) Left Coin Chute D3	1 White-Brown J208-1 U18-11	Right Inlane	Slam Tilt	Left Jet Bumper	Dead End	Gumball Popper Lane	Lower Skill	Not Used	Lower Right Magnet	Clock 15 Minutes	Black-Green J906-1 Right Flipper End of Stroke F1
Orange-Red J205-2 (2) Center Coin Chute D2	2 White-Red J208-2 U18-9	Right Outlane	Coin Door Closed	Right Jet Bumper	The Camera	Hitch-Hiker	Center Skill	Auto-Fire Kicker	Not Used	Clock 0 Minutes	Blue-Violet J905-1 Right Flipper Opto F2
Orange-Black J205-3 (3) Right Coin Chute D5	3 White-Orange J208-3 U18-5	Start Button	Buy-In Button	Lower Jet Bumper	Player Piano	Left Ramp Enter	Upper Skill	Right Ramp	Left Magnet	Clock 45 Minutes	Black-Blue J906-3 Left Flipper End of Stroke F3
Orange-Yellow J205-4 (4) 4th Coin Chute D4	4 White-Yellow J208-4 U18-7	Plumb Bob Tilt	Always Closed	Left Slingshot	Mini Playfield Enter	Left Ramp	Upper Right 5 Million	Gumball Popper	Center Lock	Clock 30 Minutes	Blue-Gray J905-2 Left Flipper Opto F4
Orange-Green J205-6 (5) Normal Function Service Credits Escape D5	5 White-Green J208-5 U18-11	Right Trough	Far Left Trough	Right Slingshot	Mini Playfield Left (2)	Gumball Geneva	Power Payoff (2)	Mini Playfield Top	Upper Lock	Clock Hour 1	Black-Violet J906-4 Upper Right Flipper End of Stroke F5
Orange-Blue J205-7 (6) Normal Function Volume Down D6	6 White-Blue J208-7 U18-9	Center Trough	Trough Proximity	Left Outlane	Mini Playfield Right (2)	Gumball Exit	Middle Right 5 Million 1	Mini Playfield Exit	Not Used	Clock Hour 2	Black-Yellow J906-3 Upper Right Flipper Opto F6
Orange-Violet J205-8 (7) Normal Function Volume Up D7	7 White-Violet J208-8 U18-5	Left Trough	Ball Shooter	Left Inlane 1	Clock Millions	Slot Proximity	Middle Right 5 Million 2	Middle Left 5 Million	Gumball Enter	Clock Hour 3	Black-Gray J906-5 Upper Left Flipper End of Stroke F7
Orange-Gray J205-9 (8) Normal Function Begin Test/Enter D8	8 White-Gray J208-9 U18-7	Outhole	Rocket Kicker	Left Inlane 2	Lower Left 5 Million	Slot Kickout	Lower Right 5 Million	Upper Left 5 Million	Lock Lower	Clock Hour 4	Black-Blue J905-5 Upper Left Flipper Opto F8

J20X = CPU Board, J30X = Fliptronic II Board * Located on 8 Driver P.C.B., A-18100, in backbox.

SWITCH LOCATIONS

Item	Switch Part #	Where Used
F1	5490-12451-00	*Lower Right Flipper EOS
F2	A-15894	*Lower Right Flipper Cabinet
F3	5490-12451-00	*Lower Left Flipper EOS
F4	A-15894	*Lower Left Flipper Cabinet
F5	5490-12451-00	*Upper Right Flipper EOS
F6	A-15894	*Upper Right Flipper Cabinet
F7	5490-12451-00	*Upper Left Flipper EOS
F8	A-15894	*Upper Left Flipper Cabinet
11	5647-12693-19	Right Inlane
12	5647-12693-19	Right Outlane
13	20-9663-1	Start Button
14	A-15361	*PlumbBob Tilt
15	5647-12693-08	Right Trough
16	5647-09957-00	Center Trough
17	5647-09957-00	Left Trough
18	5647-12133-12	Outhole
21	27-1066	*Slam Tilt
22	5643-09288-00	*Coin Door Closed
23	20-9663-9	Buy-In Button
24	----	Always Closed
25	5647-09957-00	Far Left Trough
26	A-16528	†Trough Proximity
27	5647-12693-04	Ball Shooter
28	5647-12693-55	Rocket Kicker
31	SW-11A-37	Left Jet Bumper
32	SW-11A-37	Right Jet Bumper
33	SW-11A-37	Lower Jet Bumper

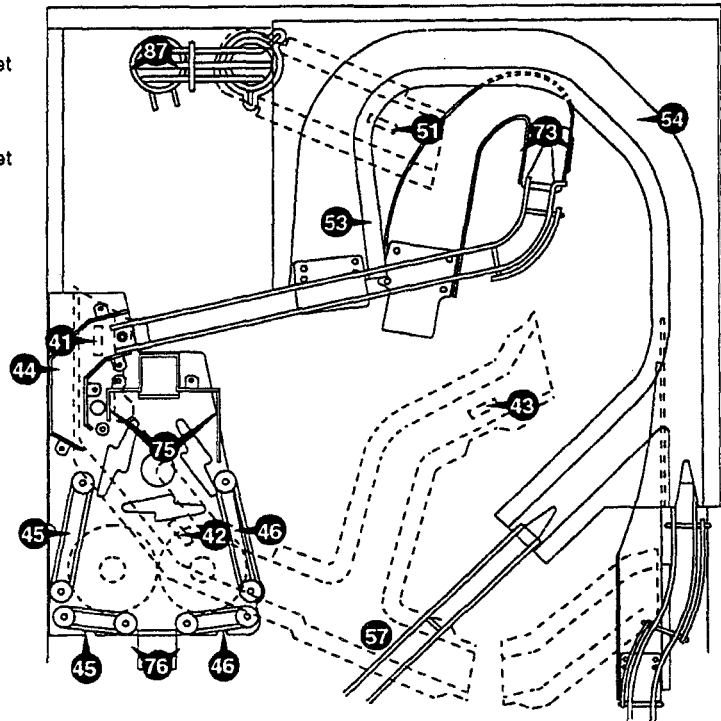

MINI-PLAYFIELD, TOP AND BOTTOM RAMP SWITCH LOCATIONS

SWITCH LOCATIONS (Continued)

Item	Switch Number	Where Used
34	SW-1A-114	Left Slingshot (kicker)
	SW-1A-120	Left Slingshot (score)
35	SW-1A-114	Right Slingshot (kicker)
	SW-1A-120	Right Slingshot (score)
36	5647-12693-19	Left Outlane
37	5647-12693-19	Left Inlane 1
38	5647-12693-19	Left Inlane 2
41	5647-12693-13	Dead End
42	5647-12693-13	Mini-playfield Top Hole
43	5647-12693-13	Player Piano
44	5647-12693-19	Mini-playfield Enter
45	5647-12693-11	Mini-playfield Left (2)
46	5647-12693-11	Mini-playfield Right (2)
47	A-15658-2	Clock Millions
48	A-14691-6	Lower Left 5 Million
51	5647-12693-13	Gumball Popper Lane
52	5647-12693-19	Hitch-hicker
53	5647-12693-11	Left Ramp Enter
54	5647-12693-21	Left Ramp
55	5647-12393-08	†Gumball Geneva
56	5647-12693-19	Gumball Exit
57	A-16535	†Slot Proximity
58	5647-12693-25	†Slot Kickout
61	5647-12693-32	Lower Skill
62	5647-12693-53	Center Skill
63	5647-12693-54	Upper Skill
64	A-14691-6	Upper Right 5 Million
65	A-14691-4	Power Payoff (2)
66	A-14691-6	Middle Right 5 Million 1
67	A-14691-6	Middle Right 5 Million 2
68	A-15658-6	Lower Right 5 Million
71	----	Not Used
72	A-14231 (LED)	Auto-Fire Kicker
	A-14232 (Trans)	
73	A-14231 (LED)	Right Ramp
	A-14232 (Trans)	
74	A-14231 (LED)	Gumball Popper
	A-14232 (Trans)	
75	A-14231 (LED)	Mini-playfield Top
	A-14232 (Trans)	
76	A-14231 (LED)	Mini-playfield Exit
	A-14232 (Trans)	
77	A-14691-6	Middle Left 5 Million
78	A-14691-6	Upper Left 5 Million
81	A-14231 (LED)	Lower Right Magnet
	A-14232 (Trans)	
82	----	Not Used
83	A-14231 (LED)	Left Magnet
	A-14232 (Trans)	
84	A-14231 (LED)	Lock Center
	A-14232 (Trans)	
85	A-14231 (LED)	Lock Upper
	A-14232 (Trans)	
86	----	Not Used
87	A-14231 (LED)	Gumball Enter
	A-14232 (Trans)	
88	5647-12133-11	Lock Lower
91	A-16220	*Clock 15 Minutes
92	A-16220	*Clock 0 Minutes
93	A-16220	*Clock 45 Minutes
94	A-16220	*Clock 30 Minutes
95	A-16219	*Clock Hour 1
96	A-16219	*Clock Hour 2
97	A-16219	*Clock Hour 3
98	A-16219	*Clock Hour 4

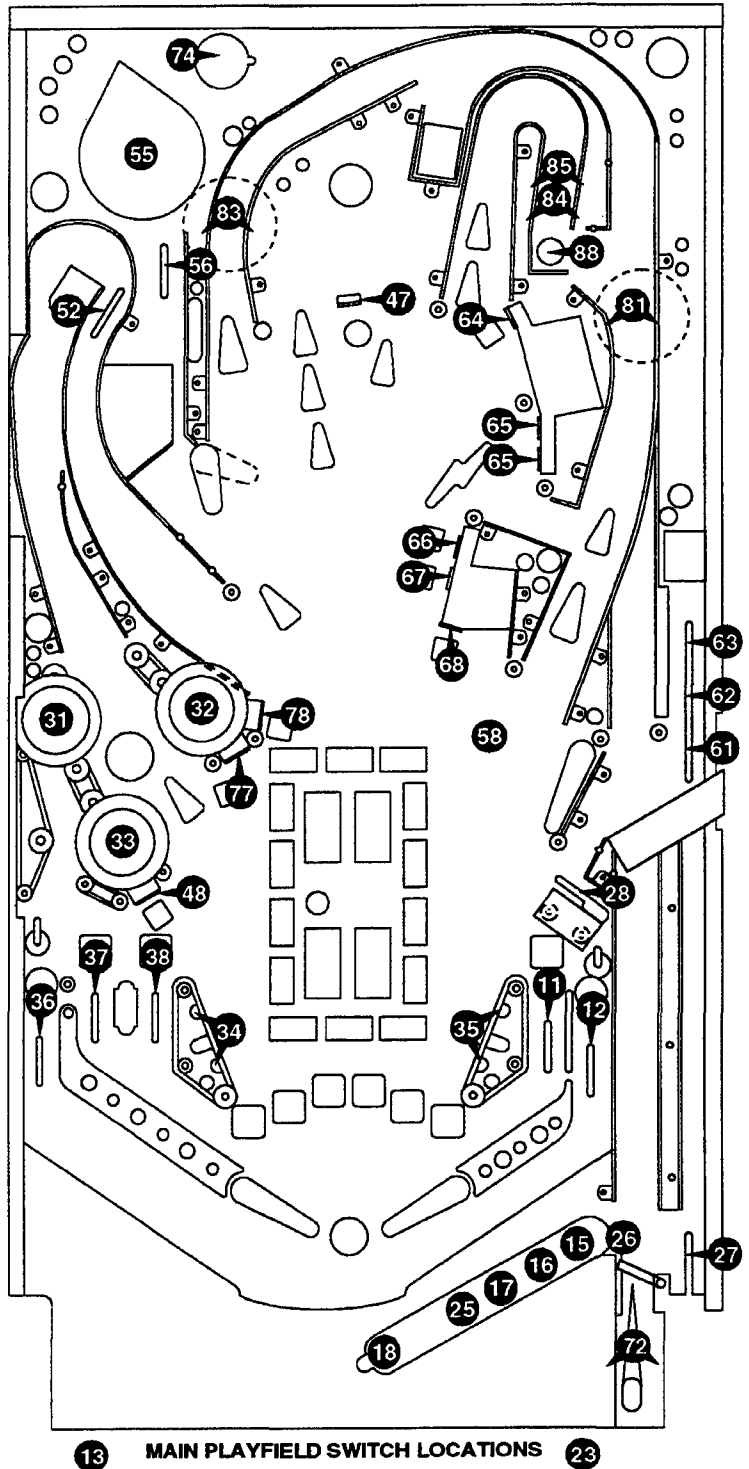

* Not shown.

† Located on underside of playfield.

SOLENOID / FLASHER TABLE

Sol. No.	Function	Solenoid Type	Voltage Connections			Drive xlator	Drive Connections			Drive Wire Color	Solenoid Part Number Flashlamp Type	
			Playfield	Backbox	Cabinet		Playfield	Backbox	Cabinet		Playfield	Backbox
01	Slot Kickout	High Power	J130-1			Q82	J107-3			Vio-Brn	AE-24-900	
02	Rocket Kicker	High Power	J130-2			Q80	J107-3			Vio-Red	AL-23-800	
03	Auto-Fire Kicker	High Power	J130-4			Q78	J107-3			Vio-Org	AL-23-800	
04	Gumball Popper	High Power	J130-5			Q76	J107-3			Vio-Yel	AE-23-800	
05	Right Ramp Diverter	High Power	J130-6			Q64	J107-3			Vio-Grn	AE-26-1200	
06	Gumball Diverter	High Power	J130-7			Q66	J107-3			Vio-Blu	AE-26-1500	
07	Knocker	High Power		J130-8		Q68		J107-3		Vio-Blk		AE-23-800
08	Outhole	High Power	J130-9			Q70	J107-3			Vio-Gry	AE-27-1200	
09	Ball Release	Low Power	J127-1			Q58	J107-2			Brn-Blk	AE-26-1200	
10	Right Slingshot	Low Power	J127-3			Q56	J107-2			Brn-Red	AE-27-1200	
11	Left Slingshot	Low Power	J127-4			Q54	J107-2			Brn-Org	AE-27-1200	
12	Lower Jet Bumper	Low Power	J127-5			Q52	J107-2			Brn-Yel	AE-26-1200	
13	Left Jet Bumper	Low Power	J127-6			Q50	J107-2			Brn-Grn	AE-26-1200	
14	Right Jet Bumper	Low Power	J127-7			Q48	J107-2			Brn-Blu	AE-26-1200	
15	Lock Release	Low Power	J127-8			Q46	J107-2			Brn-Vio	AE-27-1200	
16	Shooter Diverter	Low Power	J127-9			Q44	J107-2			Brn-Gry	SZ-33-3000	
17	Bumpers (2)	Flasher	J125-1			Q42	J107-6			Blk-Brn	#906	
18	Power Payoff (2)	Flasher	J125-2			Q40	J107-6			Blk-Red	#906	
19	Mini-Playfield (2)	Flasher	J125-3			Q38	J107-6			Blk-Org	#906	
20	Upper Left Ramp	Flasher	J125-5			Q36	J107-6			Blk-Yel	#906	
21	Left Magnet	Flasher	J125-6			Q28	J109-5			Blu-Grn	20-9247	
22	Not Used	Flasher	----			Q30	----			Blu-Blk	----	
23	Lower Right Magnet	Flasher	J125-8			Q34	J109-5			Blu-Vio	20-9247	
24	Gumball Motor	Flasher	J125-9			Q32	J107-6			Blu-Gry	14-7984	
25	Left Mini Magnet	Gen. Purpose	J124-1			Q26	J109-5			Blu-Brn	20-9247	
26	Right Mini Magnet	Gen. Purpose	J124-2			Q24	J109-7			Blu-Red	20-9247	
27	Left Ramp Diverter	Gen. Purpose	J124-3			Q22	J109-7			Blu-Org	AR-26-1500	
28	Inside Ramp	Gen. Purpose	J124-5			Q20	J107-6			Blu-Yel	#906	
37	Upper Right Flipper	Flasher	*J4-1				J107-6			Brn-Wht	#906	
38	Gumball Machine HI	Flasher	*J4-2				J107-6			Red-Wht	#906	
39	Gumball Machine Mid	Flasher	*J4-3				J107-6			Org-Wht	#906	
40	Gumball Machine Low	Flasher	*J4-5				J107-6			Yel-Wht	#906	
41	Upper Right Ramp	Flasher	*J3-5				J107-6			Grn-Wht	#906	
42	Clock Reverse	Flasher	**J1-2				**J1-5			Blu-Wht	A-16120	
43	Clock Forward	Flasher	**J1-1				**J1-5			Vio-Wht	A-16120	
44	Clock Switch Strobe	Flasher	*J5-1				J107-6			Gry-Wht	----	

General Illumination

01	Playfield Left	G.I.	J-121-1			Q18	J-121-7			Wht-Brn	24-6549	
02	Mini-playfield & Insert	G.I.	J-121-2	J-120-2		Q10	J-121-8	J-120-8		Wht-Org	24-8768	24-8768
03	Clock & Insert	G.I.	J-121-3	J-120-3		Q14	J-121-9	J-120-9		Wht-Yel	24-8829	24-8768
04	Insert Main	G.I.		J-120-5		Q16		J-120-10		Wht-Gm		24-8768
05	Playfield Right	G.I.	J-121-6			Q12	J-121-11			Wht-Vio	24-6549	

Flipper Circuits

		Voltage Connections		Drive Translators		Drive Connections		Drive Wire Colors		Coil Part Number	Coil Colors
		Playfield	Backbox	Power	Hold	Playfield	Backbox	Power	Hold		
Lower Left Flipper	Lwr. Lt. Power	J907-7 (Gry-Yel)		Q3		J902-9		Blu-Gry		FL-15411	ORANGE
	Lwr. Lt. Hold	J907-7 (Gry-Yel)			Q9	J902-7		Org-Blu			
Lower Right Flipper	Lwr. Rt. Power	J907-9 (Blu-Yel)		Q4		J902-13		Blu-Vio		FL-15411	ORANGE
	Lwr. Rt. Hold	J907-9 (Blu-Yel)			Q11	J902-11		Org-Gm			
Upper Left Flipper	Up Lt. Power	J907-1 (Gry-Yel)		Q1		J902-3		Blk-Blu		FL-11753	YELLOW
	Up Lt. Hold	J907-1 (Gry-Yel)			Q5	J902-1		Org-Gry			
Upper Right Flipper	Up Rt. Power	J907-4 (Blu-Yel)		Q2		J902-6		Blk-Yel		FL-11722	GREEN
	Up Rt. Hold	J907-4 (Blu-Yel)			Q7	J902-4		Org-Vio			

*From 8 Driver P.C.B., A-16100

**From D.C. Motor Control Assembly, A-16120

SOLENOID / FLASHER LOCATIONS

Item	Coil/Flasher Number	Assembly Number	Description
01	AE-24-900	A-16434	Slot Kickout
02	AL-23-800	A-16647	Rocket Kicker
03	AL-23-800	A-16647	Auto-Fire Kicker
04	AE-23-800	A-16312	Gumball Popper
05	AE-26-1200	A-16361	Right Ramp Diverter
06	AE-26-1500	A-16313	Gumball Diverter
07	AE-23-800	B-10686-1	Knocker
08	AE-27-1200	A-8039-3	Outhole
09	AE-26-1200	A-16766	Ball Release
10	AE-27-1200	A-16645-R	Right Slingshot
11	AE-27-1200	A-16645-L	Left Slingshot
12	AE-26-1200	A-9415-2	Lower Jet Bumper
13	AE-26-1200	A-9415-2	Left Jet Bumper
14	AE-26-1200	A-9415-2	Right Jet Bumper
15	AE-27-1200	A-16307	Lock Release
16	SZ-33-3000	A-16338	Shooter Diverter
17	24-8802	A-12336-1	Bumpers (2)
18	24-8802	A-12336-1	Power Payoff (2)
	24-8802	A-16060	
19	24-8802	A-12336-1	Mini-playfield (2)
20	24-8802	A-16330	Upper Left Ramp (2)
	24-8802	A-16060	
21	20-9247	----	Left Magnet
22	----	----	Not Used
23	20-9247	----	Lower Right Magnet
24	14-7984	A-16132	Gumball Motor
25	20-9247	A-16749	Left Mini-playfield Magnet
26	20-9247	A-16749	Right Mini-playfield Magnet
27	AE-26-1500	A-16064	Left Ramp Diverter
28	24-8802	A-16060	Inside Ramp
			Gumball Machine High
			Gumball Machine Middle
			Gumball Machine Low
37	24-8802	A-12336-1	Upper Right Flipper
38	24-8802	A-16651-4	Gumball Machine High
39	24-8802	A-16651-4	Gumball Machine Middle
40	24-8802	A-16651-4	Gumball Machine Low
41	24-8802	A-16330	Upper Right Ramp
	24-8802	A-16060	
42	----	A-16120	Clock Reverse
43	----	A-16120	Clock Forward
44	----	A-16100	Clock Strobe

General Illumination Circuits

*01	Playfield Left	24-6549	GI String 1
*02	Mini-playfield & Insert	24-8768	GI String 2
*03	Clock & Insert	24-8829, 24-8768	GI String 3
*04	Insert Main	24-8768	GI String 4
*05	Playfield Right	24-6549	GI String 5

Flipper Coils

Coil	Assembly	Description
FL-15411 (Orange)	A-15205-L-4	Lower Left Flipper
FL-15411 (Orange)	A-15205-R-4	Lower Right Flipper
FL-11753 (Yellow)	A-15205-L-1	Upper Left Flipper
FL-11722 (Green)	A-15205-R-3	Upper Right Flipper

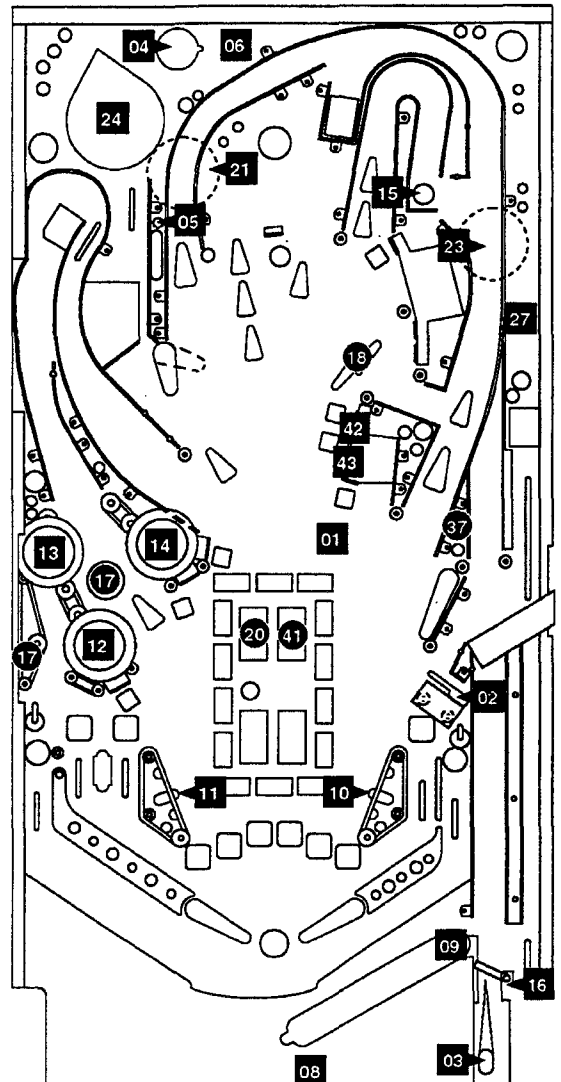
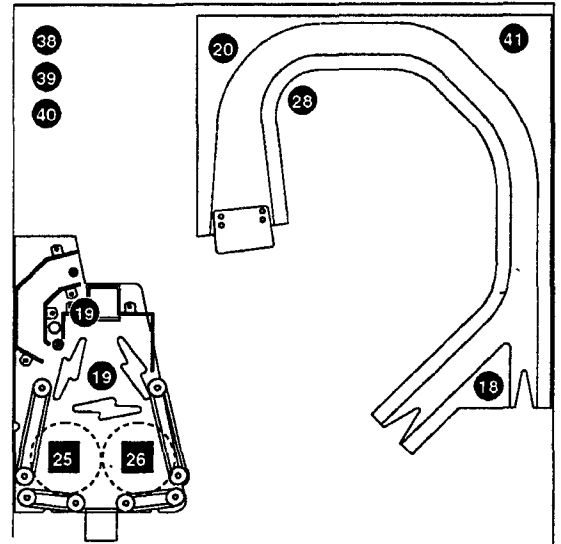

■ Square indicates coil, P.C.B. or Magnet
● Circle indicates flasher

LAMP MATRIX

Yellow (B+)  Red

Column \ Row	1 Yellow-Brown J137-1 Q98	2 Yellow-Red J137-2 Q97	3 Yellow-Orange J137-3 Q96	4 Yellow-Black J137-4 Q95	5 Yellow-Green J137-5 Q94	6 Yellow-Blue J137-6 Q93	7 Yellow-Violet J138-7 Q92	8 Yellow-Gray J138-9 Q91
1 Red-Brown J133-1 Q90	Camera (Door) 11	Door Panel "Lock 2" 21	Left Extra Ball 31	Spiral "2 Million" 41	Left Ramp Bonus X 51	Left Jet Bumper 61	Lower Right 5 Million 71	Left Spiral 81
2 Red-Black J133-2 Q89	Hitch Hicker (Door) 12	Greed (Door) 22	Door Panel "Lock 1" 32	Spiral Left Battle Power 42	Left Ramp Multiball 52	Lower Jet Bumper 62	Middle Right 5 Million 2 72	Clock Millions 82
3 Red-Orange J133-4 Q88	Clock Chaos (Door) 13	10 Million (Door) 23	Left Inlane 1 33	Spiral "4 Million" 43	Left Ramp "Super Skill" 53	Right Jet Bumper 63	Middle Right 5 Million 1 73	Piano Yellow 83
4 Red-Yellow J133-5 Q87	Super Skill (Door) 14	Battle The Power (Door) 24	Door Handle 34	Spiral Right Battle Power 44	Left Powerball 54	Middle Left 5 Million 64	Power Payoff 74	Piano Red 84
5 Red-Green J133-6 Q86	Fast Lock (Door) 15	The Spiral (Door) 25	Left Inlane 2 35	Spiral "10 Million" 45	The Camera 55	Upper Left 5 Million 65	Upper Right 5 Million 75	Slot Machine 85
6 Red-Blue J133-7 Q85	Lite Gumball (Door) 16	Clock Million (Door) 26	Door Panel "Gum" 36	Spiral "Extra Ball" 46	Right Ramp The Power 56	Right Special 66	Mini Playfield 500,000 76	Right Lane Gumball 86
7 Red-Violet J133-8 Q84	Town Square Madness (Door) 17	Super Slot (Door) 27	Lower Left 5 Million 37	Shoot Again 47	Lock Extra Ball 57	Right Powerball 67	Mini Playfield 1,000,000 77	Buy-In Button 87
8 Red-Gray J133-9 Q83	Lite Extra Ball (Door) 18	Door Panel "Ball" 28	Dead End 38	Right Inlane 48	Lock Arrow 58	Right Lane Spiral 68	Mini Playfield 750,000 78	Start Button 88

J1XX = Power Driver Board

LAMP LOCATIONS

Item No.	Bulb No.	Lamp Assy. No.	Description
11	24-8768	A-16327	Camera (Door)
12	24-8768	A-16327	Hitch-Hicker (Door)
13	24-8768	A-16327	Clock Chaos (Door)
14	24-8768	A-16327	Super Skill (Door)
15	24-8768	A-16327	Fast Lock (Door)
16	24-8768	A-16327	Lite Gumball (Door)
17	24-8768	A-16327	Town Square Madness (Door)
18	24-8768	A-16327	Lite Extra Ball (Door)
21	24-8768	A-16327	Door Panel "Lock 2"
22	24-8768	A-16327	Greed (Door)
23	24-8768	A-16327	10 Million (Door)
24	24-8768	A-16327	Battle the Power (Door)
25	24-8768	A-16327	The Spiral (Door)
26	24-8768	A-16327	Clock Million (Door)
27	24-8768	A-16327	Super Slot (Door)
28	24-8768	A-16327	Door Panel "Ball"
31	24-8768	A-16327	Left Extra Ball
32	24-8768	A-16516	Door Panel "Lock 1"
33	24-8768	A-16327	Left Inlane 1
34	24-8768	A-16516	Door Handle
35	24-8768	A-16327	Left Inlane 2
36	24-8768	A-16516	Door Panel "Gum"
37	24-8768	A-16517	Lower Left 5 Million
38	24-8768	A-16517	Dead End
41	24-8768	A-16328	Spiral "2 Million"
42	24-8768	A-16328	Spiral Left Battle Power
43	24-8768	A-16328	Spiral "4 Million"
44	24-8768	A-16328	Spiral Right Battle Power
45	24-8768	A-16328	Spiral "10 Million"
46	24-8768	A-16328	Spiral "Extra Ball"
47	24-6549	A-11754	Shoot Again
48	24-6549	A-11271	Right Inlane
51	24-8768	A-16329	Left Ramp Bonus X
52	24-8768	A-16329	Left Ramp Multiball
53	24-8768	A-16329	Left Ramp Super Skill
54	24-6549	A-11271	Left Powerball
55	24-6549	A-11754	The Camera
56	24-6549	A-11271	Right Ramp The Power
57	24-8768	A-16515	Lock Extra Ball
58	24-8768	A-16515	Lock Arrow
61	24-8768	B-9414-3	Left Jet Bumper
62	24-8768	B-9414-3	Lower Jet Bumper
63	24-8768	B-9414-3	Right Jet Bumper
64	24-8768	A-16517	Middle Left 5 Million
65	24-6549	A-11271	Upper Left 5 Million
66	24-6549	A-11271	Right Special
67	24-6549	A-11754	Right Powerball
68	24-6549	A-11271	Right Lane Spiral
71	24-8768	A-16514	Lower Right 5 Million
72	24-8768	A-16514	Middle Right 5 Million 2
73	24-8768	A-16514	Middle Right 5 Million 1
74	24-8768	A-16514	Power Payoff
75	24-8768	A-16515	Upper Right 5 Million
76	24-8768	A-12887	*Mini-playfield 500,000
77	24-8768	A-12887	*Mini-playfield 1,000,000
78	24-8768	A-12887	*Mini-playfield 750,000
81	24-8768	A-12887	*Left Spiral
82	24-6549	A-11271	Clock Millions
83	24-8768	A-12887	*Piano Yellow
84	24-8768	A-12887	*Piano Red
85	24-6549	A-11905	*Slot Machine
86	24-8768	B-12224	*Right Lane Gumball
87	---	20-9663-9	Buy-In Button
88	---	20-9663-1	Credit Button

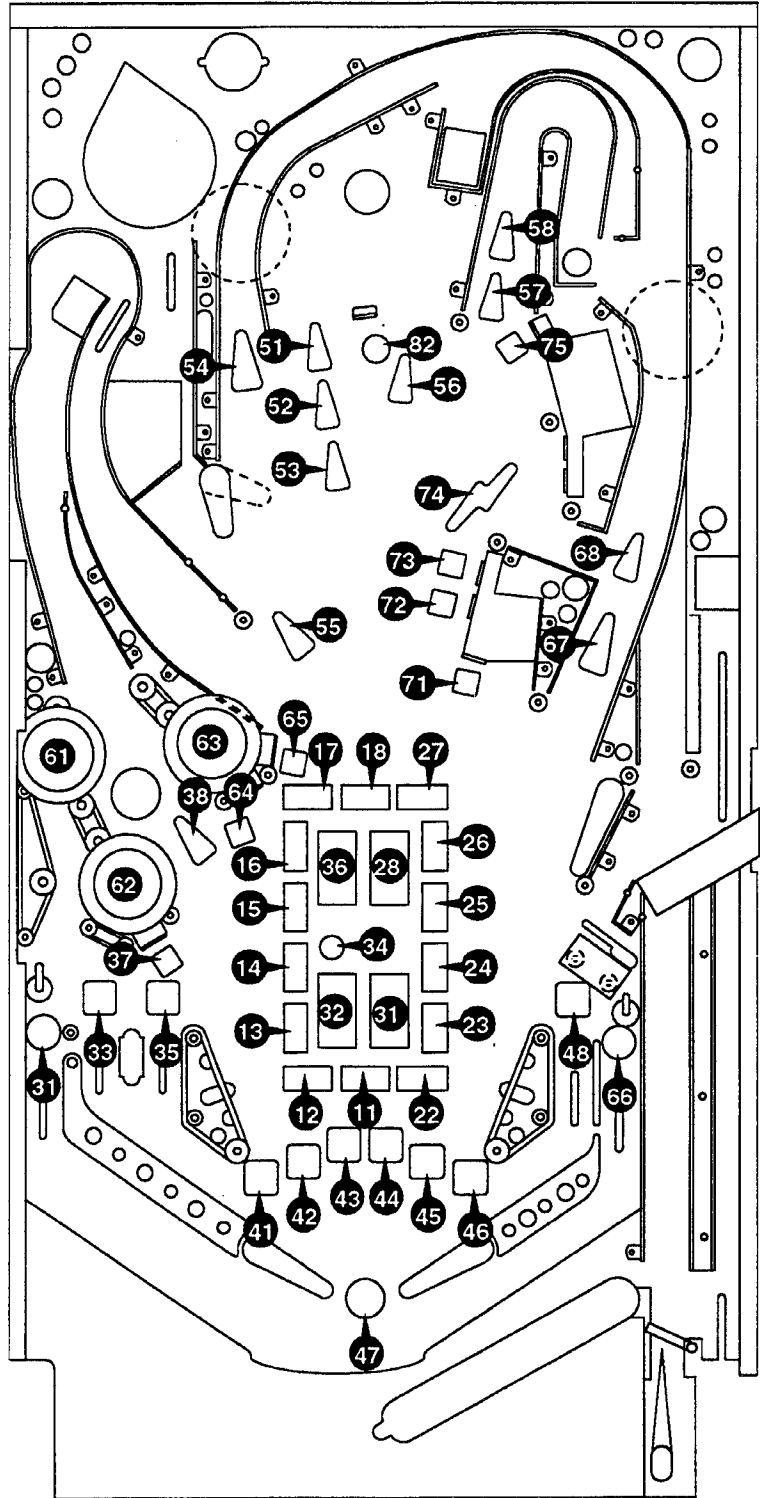

*Not Shown

24-8768 = #555 Bulb
 24-6549 = #44 Bulb

RUBBER PARTS LOCATIONS

ITEM	PART NO.	QTY	DESCRIPTION
A.	23-6300	6	5/16" Rubber Ring
B.	23-6301	4	3/4" Rubber Ring
C.	23-6302	2	1" Rubber Ring
D.	23-6303	2	1 1/4" Rubber Ring
E.	23-6305	4	2" Rubber Ring
F.	23-6306	2	2 1/2" Rubber Ring
G.	23-6519-4	3	Flipper Rubber, Red
H.	23-6535	15	Bumper
J.	23-6553-4	1	Small Flipper Rubber, Red
K.	23-6556	5	Rubber Sleeve, Black
L.	23-6327	1	Shooter Tip
M.	23-6599	4	7/16" Rubber Ring
N.	23-6686	3	*Round Bumper Pad

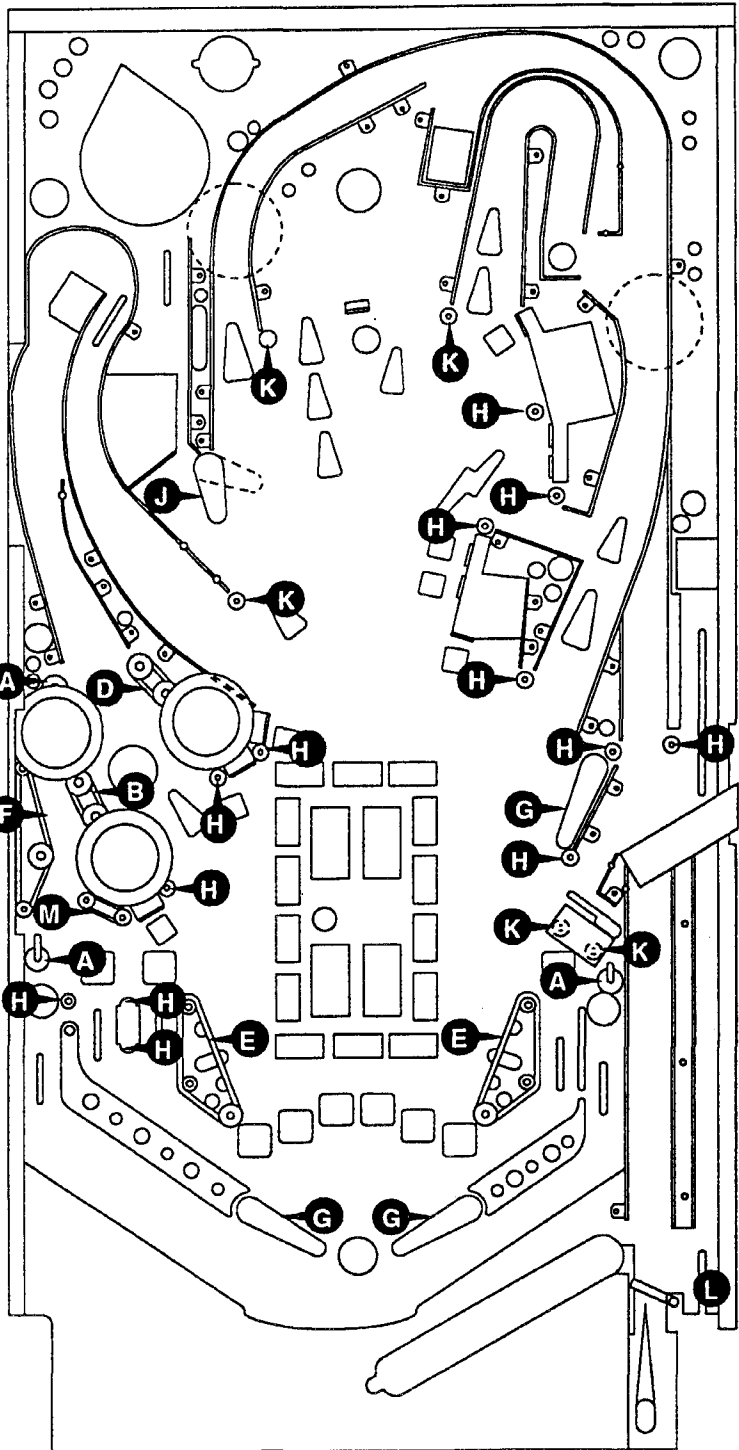
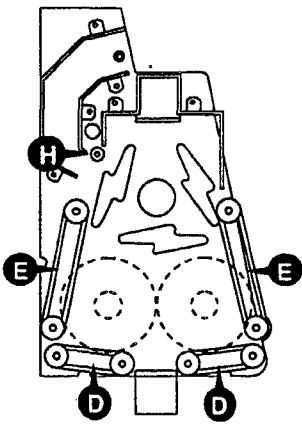

* Not shown

RAMP LOCATIONS

Item	Part Number	Part Number
1.	A-16059	Cross-Over Chute Assy.
2.	A-16164	Lock-Up Ramp Assembly
3.	A-16056	Right Chute Assembly
4.	A-16062	Center Ramp & Opto's Assy.
a)	03-8506	Opto Mtg. Base - Black
b)	03-8506-1	Opto Mtg. Base - White
5.	A-16174	Shooter Ramp Assembly
6.	A-16133	Main Chute Ass. (Under plfd.)
a)	5647-12693-13	Miniature Switch (3 used)
b)	A-16535	Ramp Prox Opto Sensor PCB
7.	A-16080	Main Ramp Assembly
a)	5647-12693-21	Miniature Switch
b)	A-13627-2	Switch Gate Assembly
8.	12-7104	Mini-Feed Wire Chute
9.	A-16058	Mini-Inside Wire Chute Assy.
10.	03-8826	Small Chute Assy. (Under plfd.)

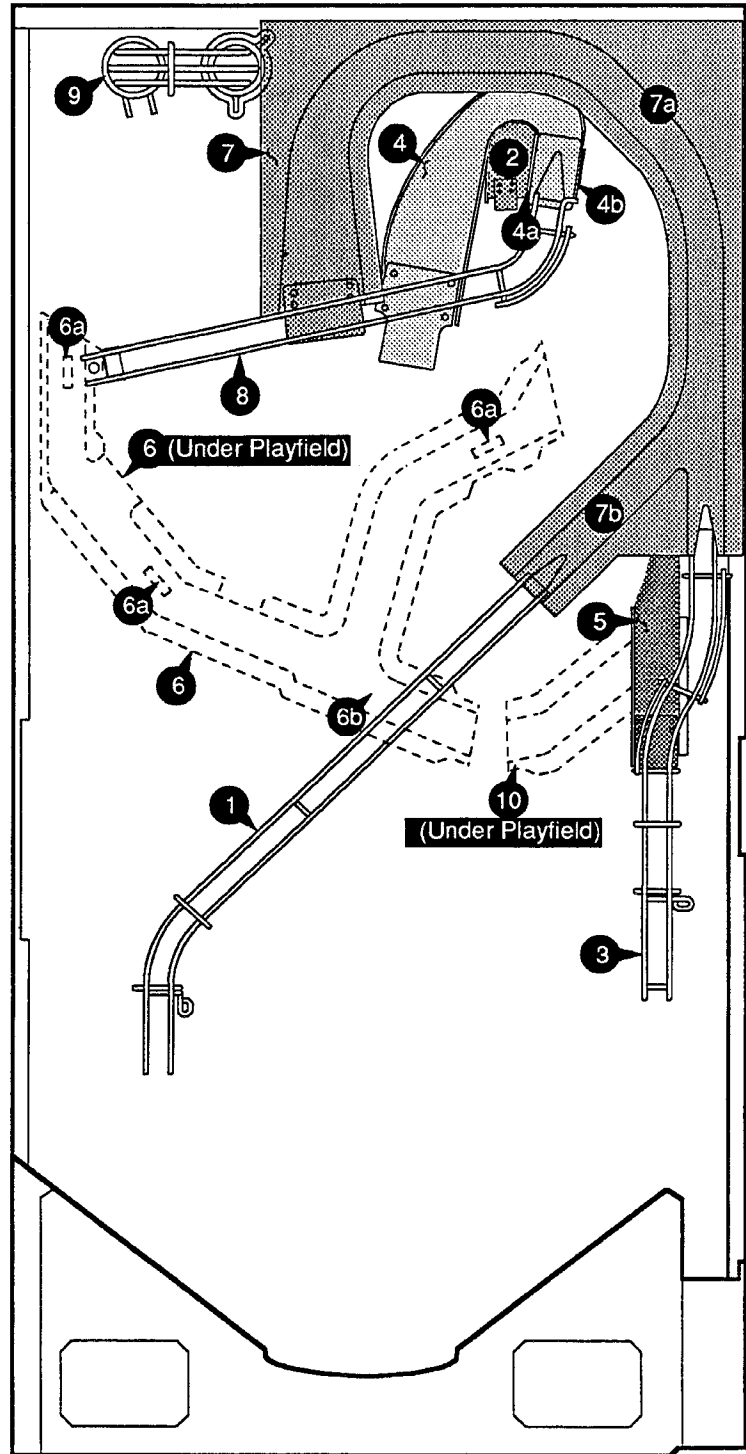

Notes

A series of horizontal dotted lines for writing notes, spanning the width of the page.

Game Wiring and Schematics

CONNECTOR & COMPONENT IDENTIFICATION

Each plug or jack receives a number that identifies the circuit board and position on that board that it connects to. J-designations refer to the male part of a connector. P-designations refer to the female part of a connector. For example, J101 designates jack 1 of board 1 (a Power Driver Board Board jack); P206 designates plug 6 of board 2 (a CPU Board plug). Identifying the specific pin number of a connector involves a hyphen, which separates the pin number from the plug or jack designation. For example, J101-3 refers to pin 3 of jack 1 on board 1.

Other game components may also have similar numbers to clarify their locations or related circuits. For example, F501 refers to a fuse located on the Sound Board.

Prefix numbers for the WPC circuit boards are listed below.

- 1- Power Driver Board
- 2- CPU Board
- 5- Sound Board
- 6- Dot Matrix Controller
Dot Matrix Display/Driver Board
- 9- Fliptronic II Controller Board

Schematics for standard WPC backbox boards are found in the WPC Schematics Manual. Playfield, cabinet, and all other backbox board schematics are found in this section.

SWITCHES

Dedicated Grounded Switches	Column Row	1	2	3	4	5	6	7	8	9	Flipper Grounded Switches
		Green-Brown J206-1 U20-18	Green-Red J206-2 U20-17	Green-Orange J206-3 U20-16	Green-Yellow J206-4 U20-15	Green-Black J206-5 L20-14	Green-Blue J206-6 U20-13	Green-Violet J206-7 U20-12	Green-Gray J206-9 U20-11	Gray-White * J5-1	
Orange-Brown (1) J205-1 Left Coin Chute D1	1 White-Brown J208-1 U18-11	Right Inlane 11	Slam Tilt 21	Left Jet Bumper 31	Dead End 41	Gumball Popper Lane 51	Lower Skill 61	Not Used 71	Lower Right Magnet 81	Clock 15 Minutes 91	Black-Green J906-1 Right Flipper End of Stroke F1
Orange-Red (2) J205-2 Center Coin Chute D2	2 White-Red J208-2 U18-9	Right Outlane 12	Coin Door Closed 22	Right Jet Bumper 32	The Camera 42	Hitch-Hiker 52	Center Skill 62	Auto-Fire Kicker 72	Not Used 82	Clock 0 Minutes 92	Blue-Violet J905-1 Right Flipper Opto F2
Orange-Black (3) J205-3 Right Coin Chute D3	3 White-Orange J208-3 U18-5	Start Button 13	Buy-In Button 23	Lower Jet Bumper 33	Player Piano 43	Left Ramp Enter 53	Upper Skill 63	Right Ramp 73	Left Magnet 83	Clock 45 Minutes 93	Black-Blue J906-3 Left Flipper End of Stroke F3
Orange-Yellow (4) J205-4 4th Coin Chute D4	4 White-Yellow J208-4 U18-7	Plumb Bob Tilt 14	Always Closed 24	Left Slingshot 34	Mini Playfield Enter 44	Left Ramp 54	Upper Right 5 Million 64	Gumball Popper 74	Center Lock 84	Clock 30 Minutes 94	Blue-Gray J905-2 Left Flipper Opto F4
Orange-Green (5) J205-6 Normal Function Service Credits Test Function Escape D5	5 White-Green J208-5 U19-11	Right Trough 15	Far Left Trough 25	Right Slingshot 35	Mini Playfield Left (2) 45	Gumball Geneva 55	Power Payoff (2) 65	Mini Playfield Top 75	Upper Lock 85	Clock Hour 1 95	Black-Violet J906-4 Upper Right Flipper End of Stroke F5
Orange-Blue (6) J205-7 Normal Function Volume Down Test Function Volume Down D6	6 White-Blue J208-7 U19-9	Center Trough 16	Trough Proximity 26	Left Outlane 36	Mini Playfield Right (2) 46	Gumball Exit 56	Middle Right 5 Million 1 66	Mini Playfield Exit 76	Not Used 86	Clock Hour 2 96	Black-Yellow J905-3 Upper Right Flipper Opto F6
Orange-Violet (7) J205-8 Normal Function Test Function Volume Up Up D7	7 White-Violet J208-8 U19-5	Left Trough 17	Ball Shooter 27	Left Inlane 1 37	Clock Millions 47	Slot Proximity 57	Middle Right 5 Million 2 67	Middle Left 5 Million 77	Gumball Enter 87	Clock Hour 3 97	Black-Gray J906-5 Upper Left Flipper End of Stroke F7
Orange-Gray (8) J205-9 Normal Function Test Function Begin Test Enter D8	8 White-Gray J208-9 U19-7	Outhole 18	Rocket Kicker 28	Left Inlane 2 38	Lower Left 5 Million 48	Slot Kickout 58	Lower Right 5 Million 68	Upper Left 5 Million 78	Lock Lower 88	Clock Hour 4 98	Black-Blue J905-5 Upper Left Flipper Opto F8

J2XX = CPU Board, J9XX = Fliptronic II Board

* Located on 8 Driver P.C.B., A-16100, In backbox.

SWITCH MATRIX CIRCUIT

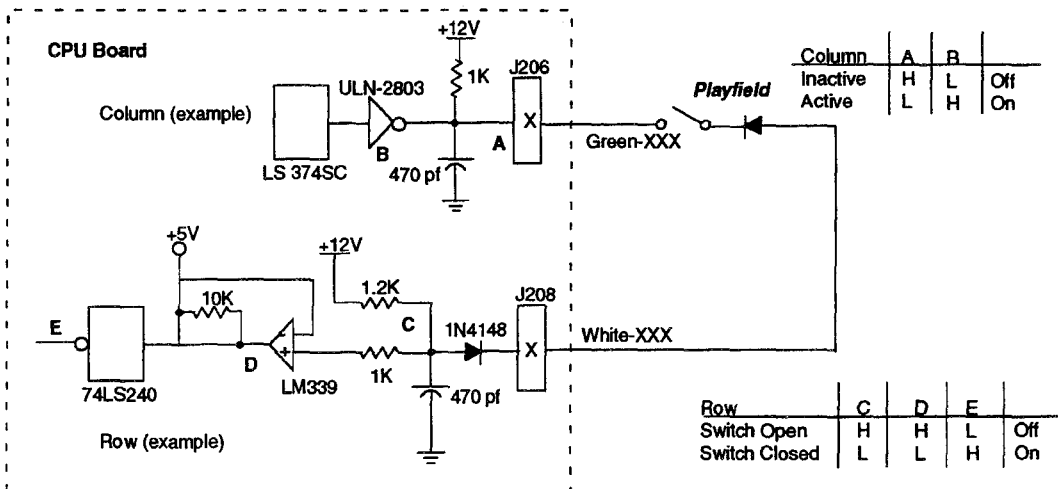

The microprocessor is constantly strobing the column side of the switch. When point "A" on the column circuit toggles low the column side is active.

When a switch closes, the row side of the circuit activates. The "+" input to the LM339 drops below +5V causing its output to go low. Corresponding row and column switches must be low at the same time, for the switch to be considered closed by the microprocessor. When the switch opens, the "+" input to the LM339 is above +5V, its output is high and the row is inactive.

DEDICATED SWITCHES

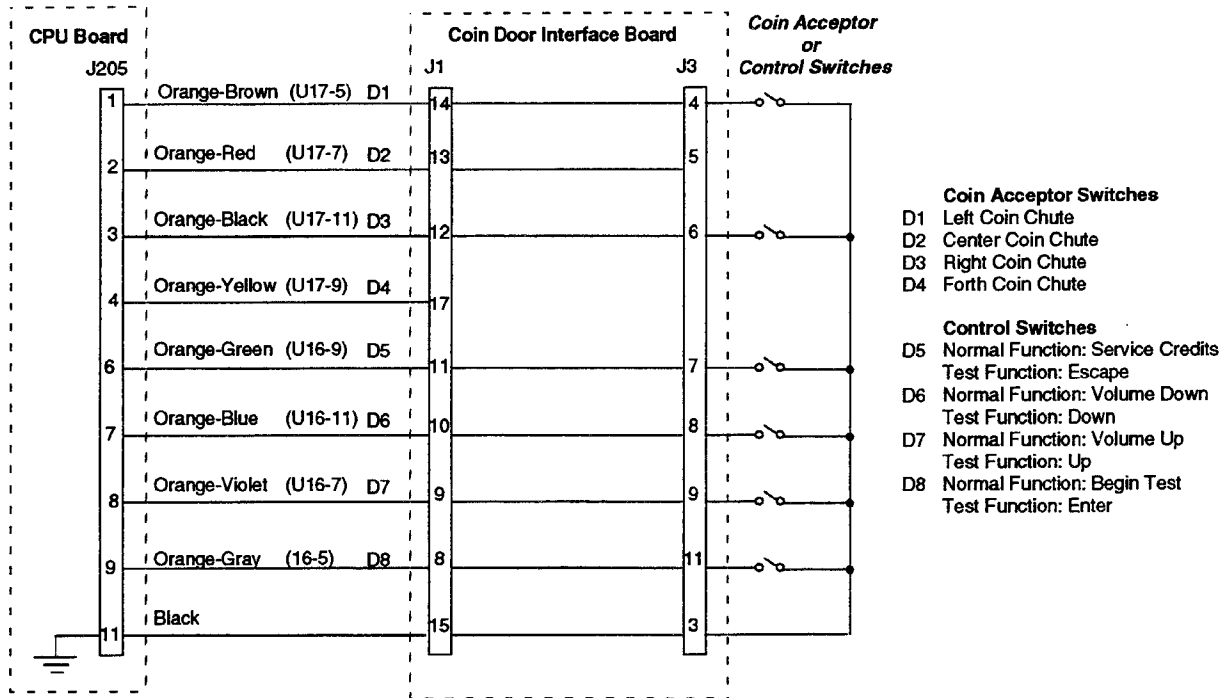

- Coin Acceptor Switches**
- D1 Left Coin Chute
 - D2 Center Coin Chute
 - D3 Right Coin Chute
 - D4 Forth Coin Chute
- Control Switches**
- D5 Normal Function: Service Credits
Test Function: Escape
 - D6 Normal Function: Volume Down
Test Function: Down
 - D7 Normal Function: Volume Up
Test Function: Up
 - D8 Normal Function: Begin Test
Test Function: Enter

DEDICATED SWITCH CIRCUIT

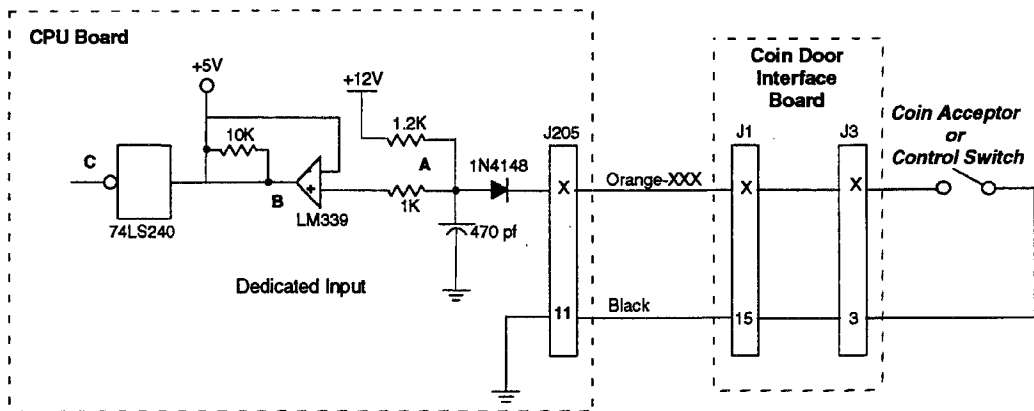

Switch	A	B	C	
Open	H	H	L	Off
Closed	L	L	H	On

The dedicated switches operate similar to switches in the matrix except that instead of a column circuit there is a direct tie to ground. Therefore, the column side is constantly active (low).

When a switch closes the row side (dedicated input) of the circuit activates. The "+" input to the LM339 drops below +5V causing its output to go low. Since the row circuit (dedicated input) is tied directly to ground through the switch, the switch is considered closed by the microprocessor. When the switch opens, the "+" input to the LM339 is above +5V, its output is high and the row is inactive.

LAMPS

Yellow (B+)  Red

Column \ Row	1 Yellow-Brown J137-1 Q98	2 Yellow-Red J137-2 Q97	3 Yellow-Orange J137-3 Q96	4 Yellow-Black J137-4 Q95	5 Yellow-Green J137-5 Q94	6 Yellow-Blue J137-6 Q93	7 Yellow-Violet J138-7 Q92	8 Yellow-Gray J138-9 Q91
1 Red-Brown J133-1 Q90	Camera (Door) 11	Door Panel "Lock 2" 21	Left Extra Ball 31	Spiral "2 Million" 41	Left Ramp Bonus X 51	Left Jet Bumper 61	Lower Right 5 Million 71	Left Spiral 81
2 Red-Black J133-2 Q89	Hitch Hicker (Door) 12	Greed (Door) 22	Door Panel "Lock 1" 32	Spiral Left Battle Power 42	Left Ramp Multiball 52	Lower Jet Bumper 62	Middle Right 5 Million 2 72	Clock Millions 82
3 Red-Orange J133-4 Q88	Clock Chaos (Door) 13	10 Million (Door) 23	Left Inlane 1 33	Spiral "4 Million" 43	Left Ramp "Super Skill" 53	Right Jet Bumper 63	Middle Right 5 Million 1 73	Plano Yellow 83
4 Red-Yellow J133-5 Q87	Super Skill (Door) 14	Battle The Power (Door) 24	Door Handle 34	Spiral Right Battle Power 44	Left Powerball 54	Middle Left 5 Million 64	Power Payoff 74	Plano Red 84
5 Red-Green J133-6 Q86	Fast Lock (Door) 15	The Spiral (Door) 25	Left Inlane 2 35	Spiral "10 Million" 45	The Camera 55	Upper Left 5 Million 65	Upper Right 5 Million 75	Slot Machine 85
6 Red-Blue J133-7 Q85	Lite Gumball (Door) 16	Clock Million (Door) 26	Door Panel "Gum" 36	Spiral "Extra Ball" 46	Right Ramp The Power 56	Right Special 66	Mini Playfield 500,000 76	Right Lane Gumball 86
7 Red-Violet J133-8 Q84	Town Square Madness (Door) 17	Super Slot (Door) 27	Lower Left 5 Million 37	Shoot Again 47	Lock Extra Ball 57	Right Powerball 67	Mini Playfield 1,000,000 77	Buy-In Button 87
8 Red-Gray J133-9 Q83	Lite Extra Ball (Door) 18	Door Panel "Ball" 28	Dead End 38	Right Inlane 48	Lock Arrow 58	Right Lane Spiral 68	Mini Playfield 750,000 78	Start Button 88

J1XX = Power Driver Board

LAMP MATRIX CIRCUIT

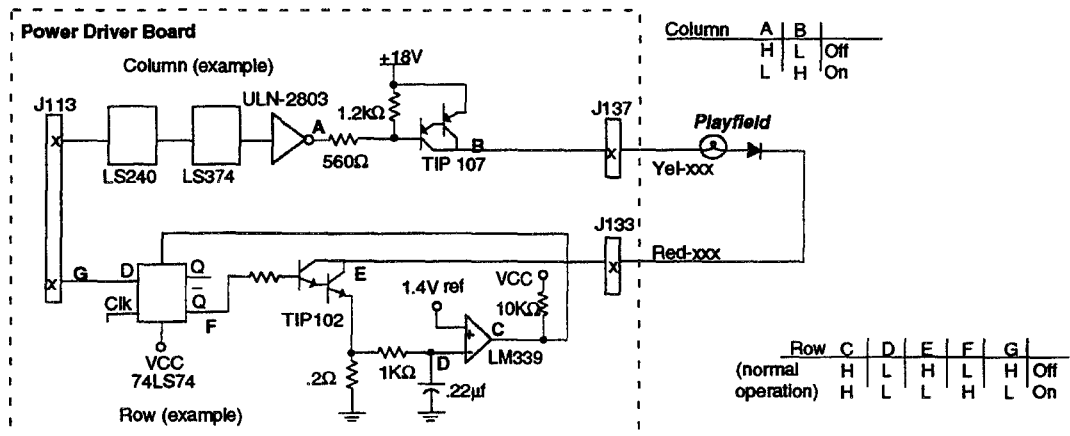

The processor sends a signal to the column circuit, causing the output of the UNL-2803 to toggle. When point "A" drops low, the TIP107 transistor conducts and point "B" changes to a high state. At the same time the processor drives the input of the 74LS74 low, causing a high at output "F". A high state at the base of TIP102 causes the transistor to conduct, bringing the row circuit to ground and turning the lamp On.

The processor changes the input of the 74LS74 to a high state to turn the lamp Off.

In overcurrent conditions the lamp is shut Off through the comparator. If the voltage at the negative input of the LM339 rises above 1.4V the output changes to a low, which is fed back to the 74LS74 and shuts the row circuit Off.

SOLENOID / FLASHER TABLE

Sol. No.	Function	Solenoid Type	Voltage Connections			Driver	Drive Connections			Drive Wire Color	Solenoid Part Number Flashlamp Type	
			Playfield	Backbox	Cabinet		Playfield	Backbox	Cabinet		Playfield	Backbox
01	Slot Kickout	High Power	J130-1			Q82	J107-3			Vio-Brn	AE-24-900	
02	Rocket Kicker	High Power	J130-2			Q80	J107-3			Vio-Red	AL-23-800	
03	Auto-Fire Kicker	High Power	J130-4			Q78	J107-3			Vio-Org	AL-23-800	
04	Gumball Popper	High Power	J130-5			Q76	J107-3			Vio-Yel	AE-23-800	
05	Right Ramp Diverter	High Power	J130-6			Q64	J107-3			Vio-Grn	AE-26-1200	
06	Gumball Diverter	High Power	J130-7			Q66	J107-3			Vio-Blu	AE-26-1500	
07	Knocker	High Power		J130-8		Q68		J107-3		Vio-Blk		AE-23-800
08	Outhole	High Power	J130-9			Q70	J107-3			Vio-Gry	AE-27-1200	
09	Ball Release	Low Power	J127-1			Q58	J107-2			Brn-Blk	AE-26-1200	
10	Right Slingshot	Low Power	J127-3			Q56	J107-2			Brn-Red	AE-27-1200	
11	Left Slingshot	Low Power	J127-4			Q54	J107-2			Brn-Org	AE-27-1200	
12	Lower Jet Bumper	Low Power	J127-5			Q52	J107-2			Brn-Yel	AE-26-1200	
13	Left Jet Bumper	Low Power	J127-6			Q50	J107-2			Brn-Grn	AE-26-1200	
14	Right Jet Bumper	Low Power	J127-7			Q48	J107-2			Brn-Blu	AE-26-1200	
15	Lock Release	Low Power	J127-8			Q46	J107-2			Brn-Vio	AE-27-1200	
16	Shooter Diverter	Low Power	J127-9			Q44	J107-2			Brn-Gry	SZ-33-3000	
17	Bumpers (2)	Flasher	J125-1			Q42	J107-6			Blk-Brn	#906	
18	Power Payoff (2)	Flasher	J125-2			Q40	J107-6			Blk-Red	#906	
19	Mini-Playfield (2)	Flasher	J125-3			Q38	J107-6			Blk-Org	#906	
20	Upper Left Ramp	Flasher	J125-5			Q36	J107-6			Blk-Yel	#906	
21	Left Magnet	Flasher	J125-6			Q28	J109-5			Blu-Grn	20-9247	
22	Not Used	Flasher	---			Q30	---			Blu-Blk	---	
23	Lower Right Magnet	Flasher	J125-8			Q34	J109-5			Blu-Vio	20-9247	
24	Gumball Motor	Flasher	J125-9			Q32	J107-6			Blu-Gry	14-7984	
25	Left Mini Magnet	Gen. Purpose	J124-1			Q26	J109-5			Blu-Brn	20-9247	
26	Right Mini Magnet	Gen. Purpose	J124-2			Q24	J109-7			Blu-Red	20-9247	
27	Left Ramp Diverter	Gen. Purpose	J124-3			Q22	J109-7			Blu-Org	AF-26-1500	
28	Inside Ramp	Gen. Purpose	J124-5			Q20	J107-6			Blu-Yel	#906	
37	Upper Right Flipper	Flasher	*J4-1				J107-6			Brn-Wht	#906	
38	Gumball Machine Hi	Flasher	*J4-2				J107-6			Red-Wht	#906	
39	Gumball Machine Mid	Flasher	*J4-3				J107-6			Org-Wht	#906	
40	Gumball Machine Low	Flasher	*J4-5				J107-6			Yel-Wht	#906	
41	Upper Right Ramp	Flasher	*J3-5				J107-6			Grn-Wht	#906	
42	Clock Reverse	Flasher	**J1-2				**J1-5			Blu-Wht	A-16120	
43	Clock Forward	Flasher	**J1-1				**J1-5			Vio-Wht	A-16120	
44	Clock Switch Strobe	Flasher	*J5-1				J107-6			Gry-Wht	---	

General Illumination

01	Playfield Left	G.I.	J-121-1			Q18	J-121-7			Wht-Brn	24-6549	
02	Mini-playfield & Insert	G.I.	J-121-2	J-120-2		Q10	J-121-8	J-120-8		Wht-Org	24-8768	24-8768
03	Clock & Insert	G.I.	J-121-3	J-120-3		Q14	J-121-9	J-120-9		Wht-Yel	24-8829	24-8768
04	Insert Main	G.I.		J-120-5		Q16		J-120-10		Wht-Grn		24-8768
05	Playfield Right	G.I.	J-121-6			Q12	J-121-11			Wht-Vio	24-6549	

Flipper Circuits

Flipper Circuits		Voltage Connections		Drive Transistors		Drive Connections		Drive Wire Colors		Coil Part Number	Coil Colors
		Playfield	Power	Power	Hold	Playfield	Power	Hold			
Lower Left Flipper	Lwr. Lt. Power	J907-7 (Gry-Yel)		Q3		J902-9		Blu-Gry		FL-15411	ORANGE
	Lwr. Lt. Hold	J907-7 (Gry-Yel)			Q9	J902-7		Org-Blu			
Lower Right Flipper	Lwr. Rt. Power	J907-9 (Blu-Yel)		Q4		J902-13		Blu-Vio		FL-15411	ORANGE
	Lwr. Rt. Hold	J907-9 (Blu-Yel)			Q11	J902-11		Org-Grn			
Upper Left Flipper	Up Lt. Power	J907-1 (Gry-Yel)		Q1		J902-3		Blk-Blu		FL-11753	YELLOW
	Up Lt. Hold	J907-1 (Gry-Yel)			Q5	J902-1		Org-Gry			
Upper Right Flipper	Up Rt. Power	J907-4 (Blu-Yel)		Q2		J902-6		Blk-Yel		FL-11722	GREEN
	Up Rt. Hold	J907-4 (Blu-Yel)			Q7	J902-4		Org-Vio			

*From 8 Driver P.C.B., A-16100

**From D.C. Motor Control Assembly, A-16120

SOLENOID WIRING

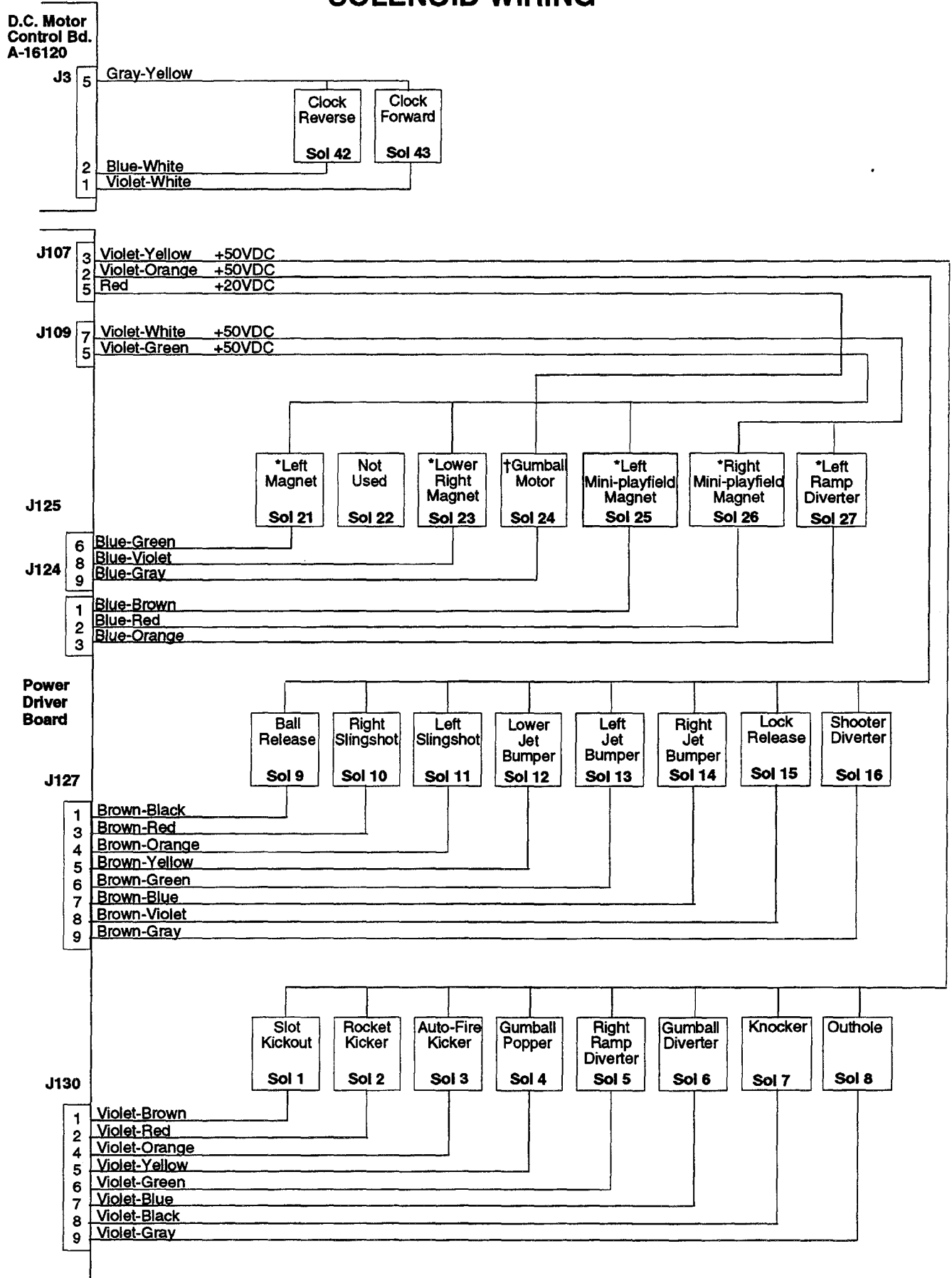

FLASHER WIRING

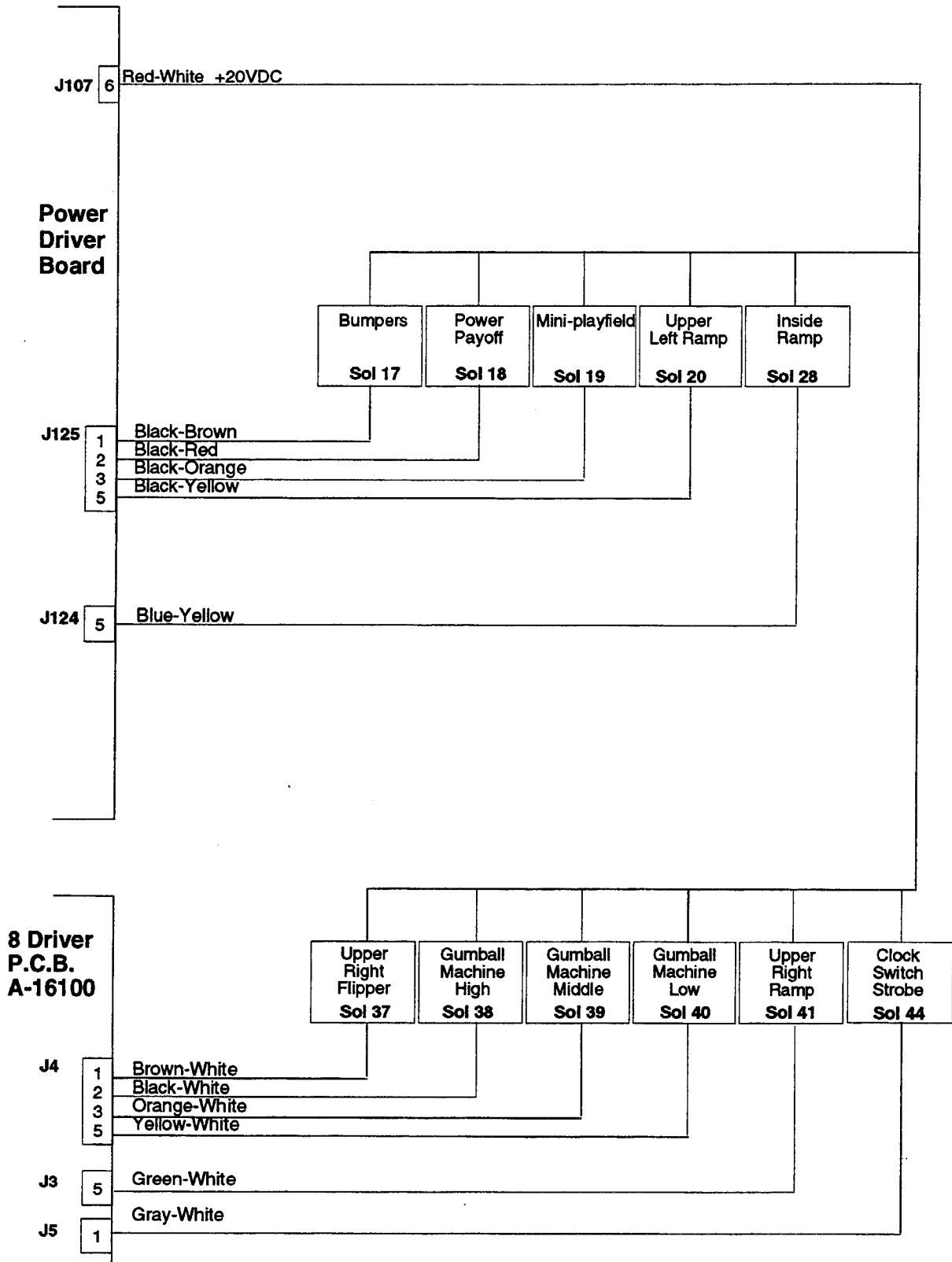

High Power Solenoid Circuit

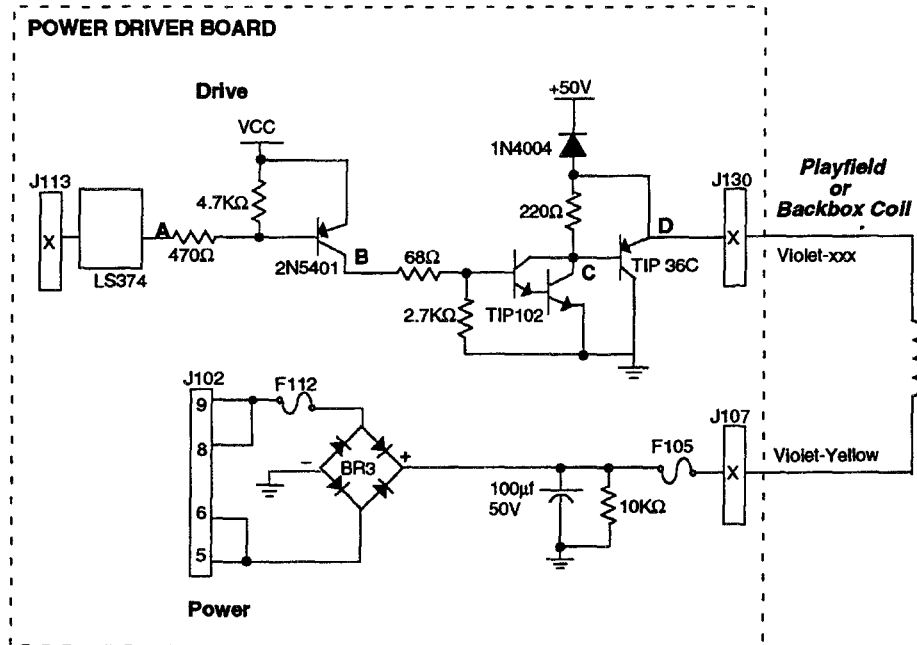

The microprocessor toggles the output of the 74LS374. When point "A" drops low, point "B" the collector of the 2N5401 transistor is high. A high at point "B" causes point "C" the collector of the TIP102 transistor, and point "D" the emitter of the TIP36 transistor to drop low. When point "D" is low the coil is grounded through the transistor and the coil turns On. The coil shuts Off when point "A" toggles high.

Low Power Solenoid Circuit

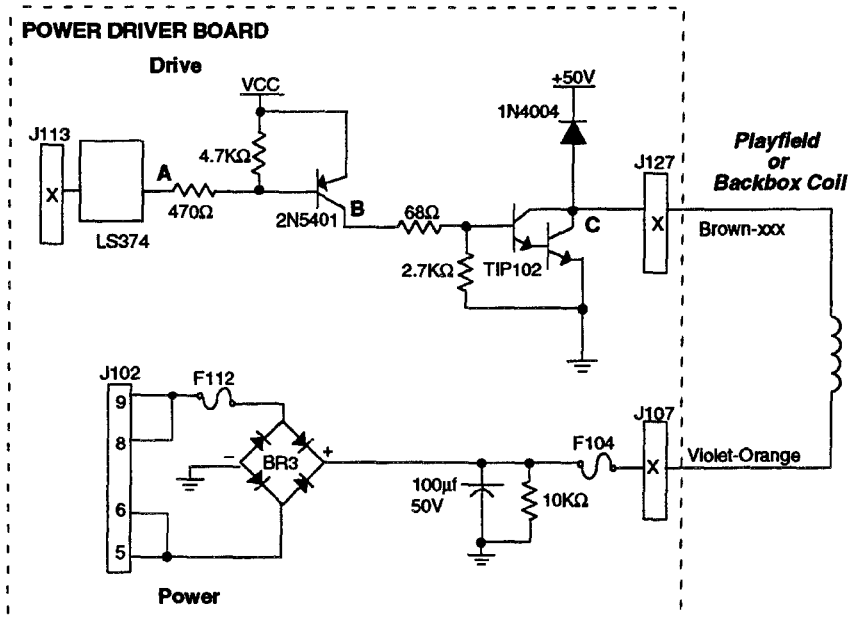

The microprocessor toggles the output of the 74LS374. When point "A" is low, point "B" the collector of the 2N5401 transistor is driven high. A high at point "B" turns On the TIP102 transistor and causes point "C" to drop low. When point "C" is low the coil is grounded through the transistor and the coil turns On. The coil shuts Off when point "A" toggles high.

Flashlamp Circuit

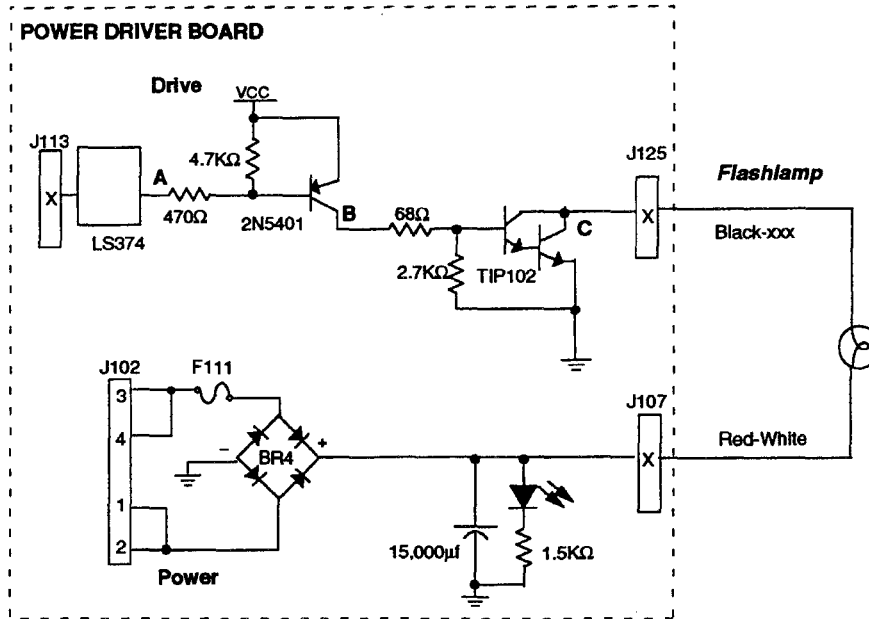

The microprocessor toggles the output of the 74LS374. When point "A" is low, point "B" the collector of the 2N5401 transistor is high. Once point "B" is high, point "C" the collector of the TIP102 transistor is low. When Point "C" is low the flashlamp is grounded through the transistor and the flashlamp turns On. When point "A" toggles high the circuit shuts Off.

Special (General Purpose) Solenoid Circuit

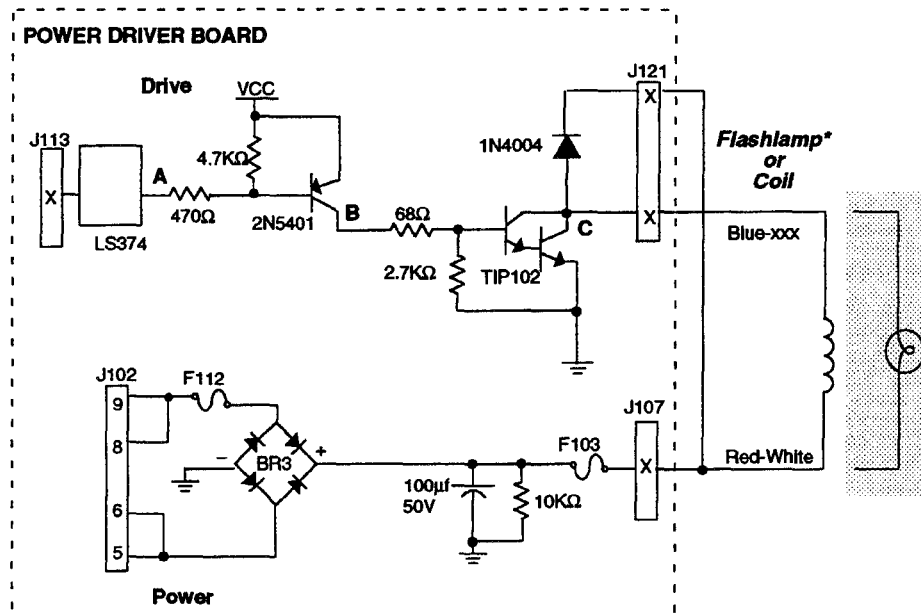

The microprocessor toggles the output of the 74LS374. When point "A" drops low, point "B" is high. A high at point "B" causes a low at point "C". When point "C" is low the coil/flashlamp is grounded through the transistor and the coil/flashlamp turns On. When point "A" toggles high the coil/flashlamp turns Off.

* Tieback Diode is not used for flashlamp circuit.

General Illumination Circuit

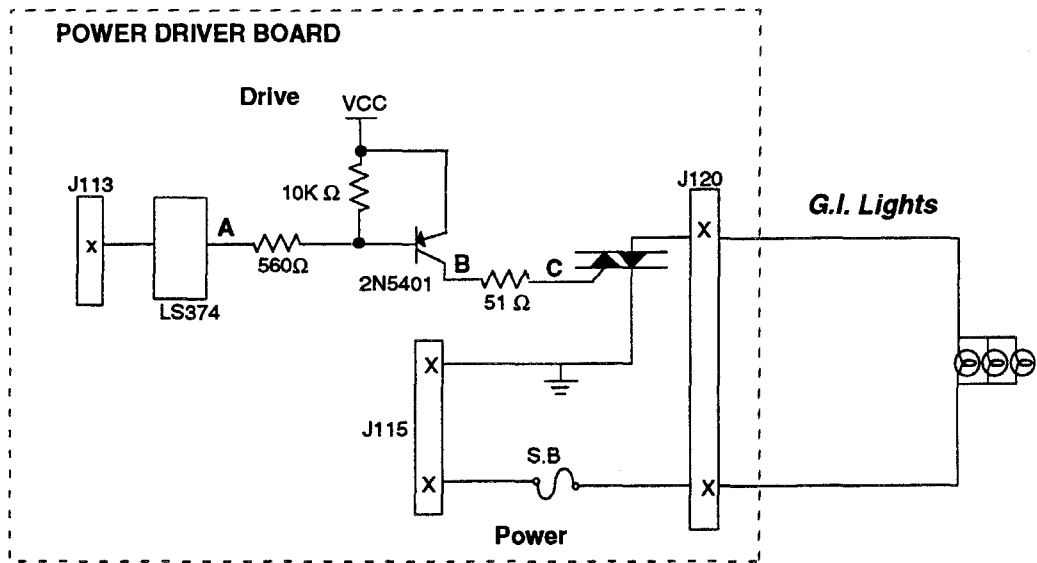

Block Diagram of General Illumination Circuit

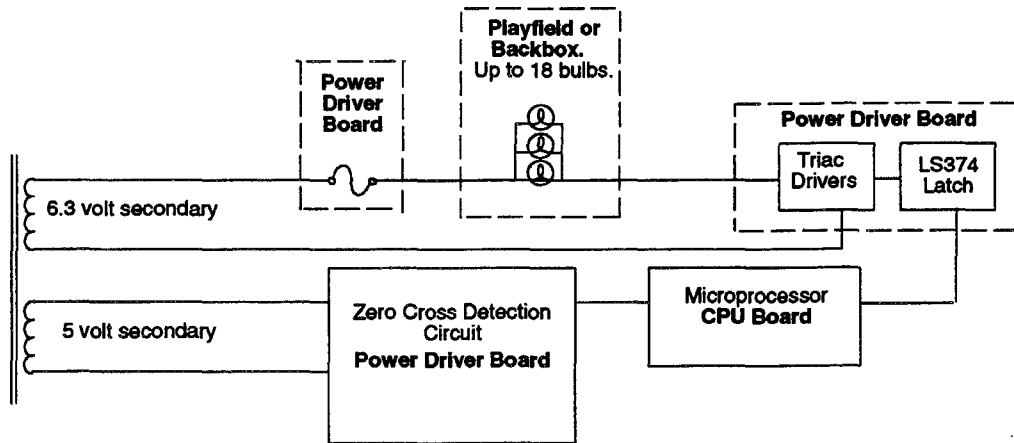

When point "A" toggles low, then points "B" and "C" are high. This turns On the triac and the desired General Illumination string lights.

Notes...

A series of 25 horizontal dotted lines for writing notes.

8 Driver P.C.B. Assembly A-16100

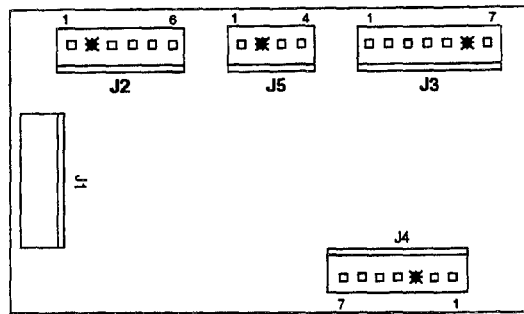

J1-1 Ribbon Cable, Data from J204

J2-1 Black-White from J114-7

J2-2 Key

J2-3 Gray from J114-3

J2-4 Black, Ground from J103-2

J2-5 Black, Ground from J103-1

J2-6 Gray-Green from J114-1

J3-1 Not Used

J3-2 Green-White to Flasher, Sol. 41

J3-3 Blue-White to J1-2, A-16120

J3-4 Not Used

J3-5 Not Used

J3-6 Key

J3-7 Not Used

J4 -1 Not Used

J4 -2 Brown-White to Flasher, Sol. 37

J4 -3 Key

J4 -4 Black-White to Flasher, Sol. 38

J4 -5 Orange-White to Flasher, Sol. 39

J4 -6 Yellow-White to Flasher, Sol. 40

J4 -7 Not Used

J5-1 Gray-White, Column 9, drive to clock optos

J5-2 Key

J5-3 Not Used

J5-4 Violet-White to J1-1, A-16120

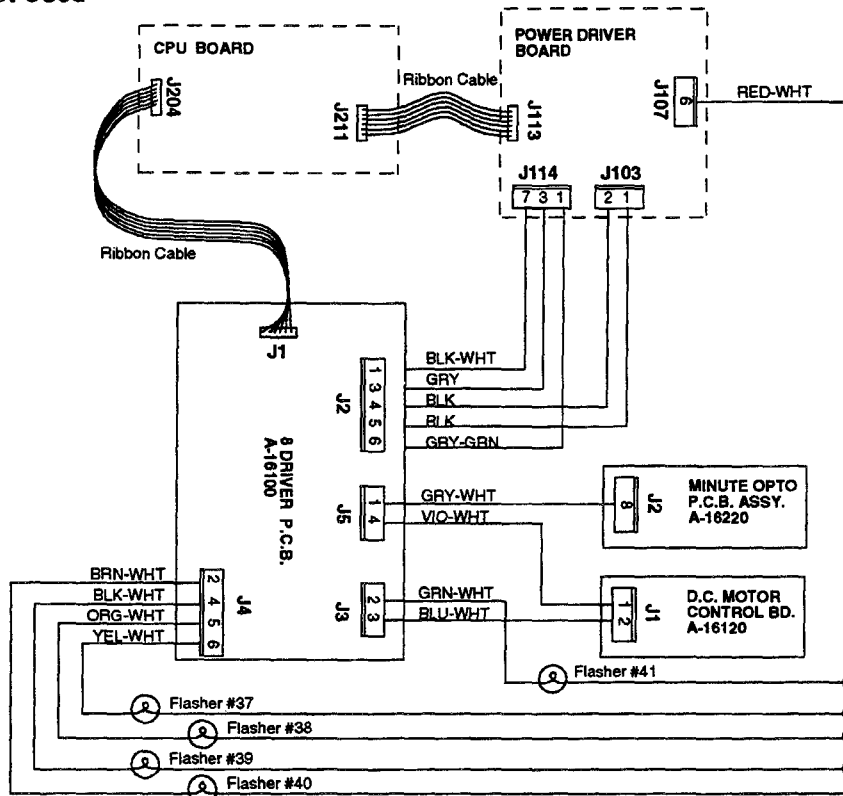

8 Driver P.C.B. Assembly A-16100

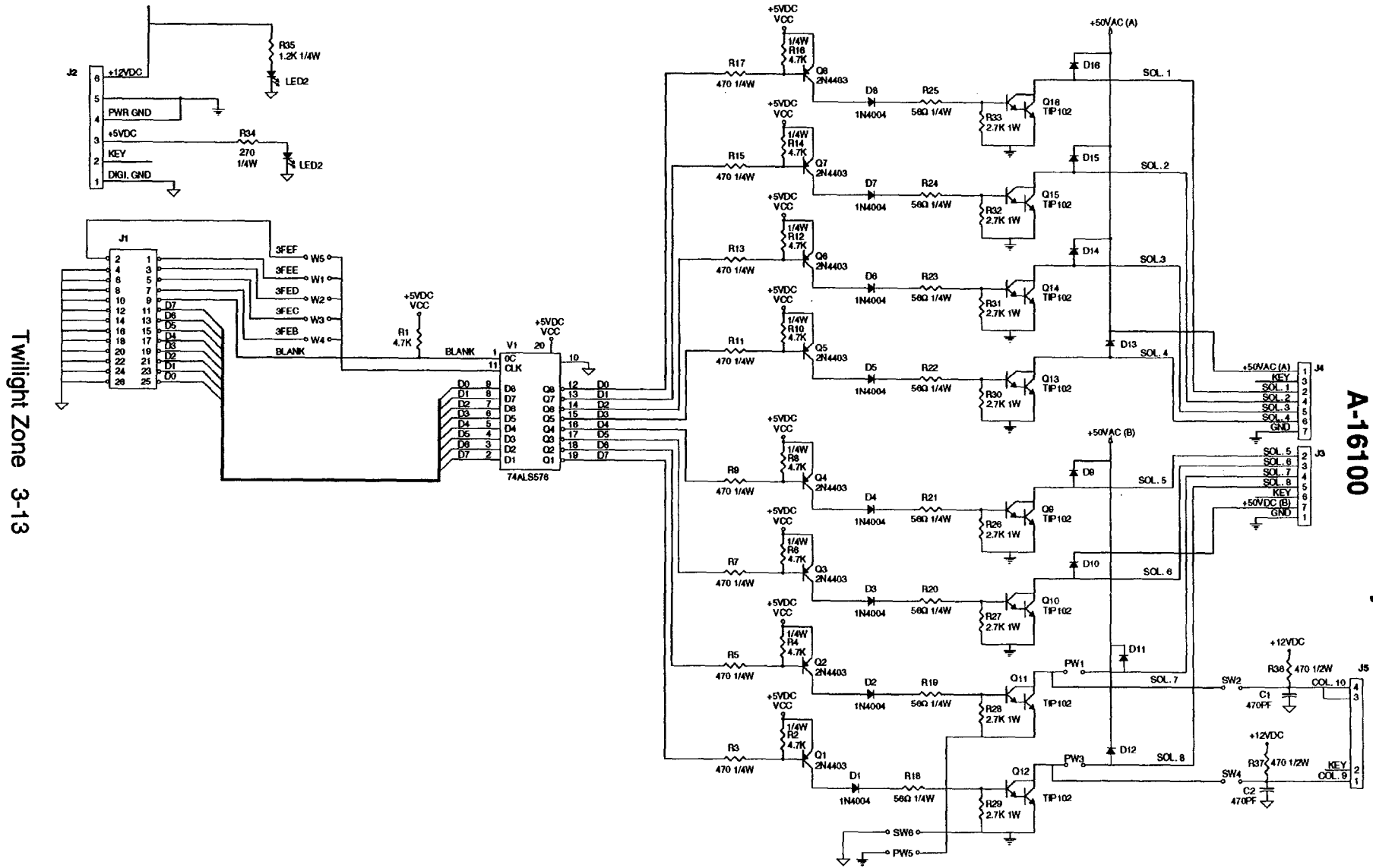

Twilight Zone 3-13

8 High Power Driver P.C.B. Assembly A-16116

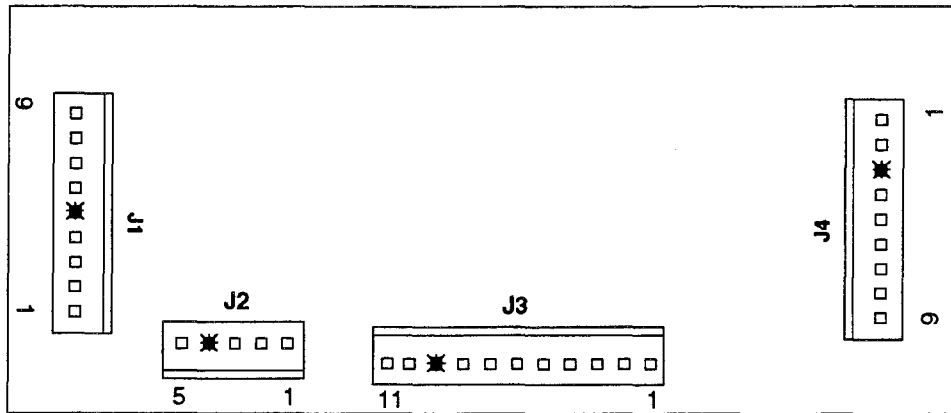

- J1-1 Violet-White to Solenoid 26, Mini-playfield Right Magnet
- J1-2 Violet-White to Solenoid 27, Left Ramp Diverter
- J1-3 Not Used
- J1-4 Not Used
- J1-5 Key
- J1-6 Not Used
- J1-7 Not Used
- J1-8 Blue-Red to Solenoid 26, Mini-playfield Right Magnet
- J1-9 Blue-Orange to Solenoid 27, Left Ramp Diverter

- J2-1 Black, Ground from J103-3
- J2-2 Black, Ground from J103-4
- J2-3 Violet-Green, from J109-5
- J2-4 Key
- J2-5 Violet-White, from J109-7

- J3-1 Blue-Green from J125-6
- J3-2 Not Used
- J3-3 Blue-Violet from J125-8
- J3-4 Blue-Brown from J124-1
- J3-5 Blue-Red from J124-2
- J3-6 Blue-Orange from J124-3
- J3-7 Not Used
- J3-8 Not Used
- J3-9 Key
- J3-10 Not Used
- J3-11 Not Used

- J4-1 Not Used
- J4-2 Violet to Solenoid 21, Left Magnet
- J4-3 Key
- J4-4 Violet to Solenoid 23, Lower Right Magnet
- J4-5 Violet to Solenoid 25, Mini-playfield Left Magnet
- J4-6 Blue-Violet to Solenoid 23, Lower Right Magnet
- J4-7 Blue-Brown to Solenoid 25, Mini-playfield Left Magnet
- J4-8 Blue-Green to Solenoid 21, Left Magnet
- J4-9 Not Used

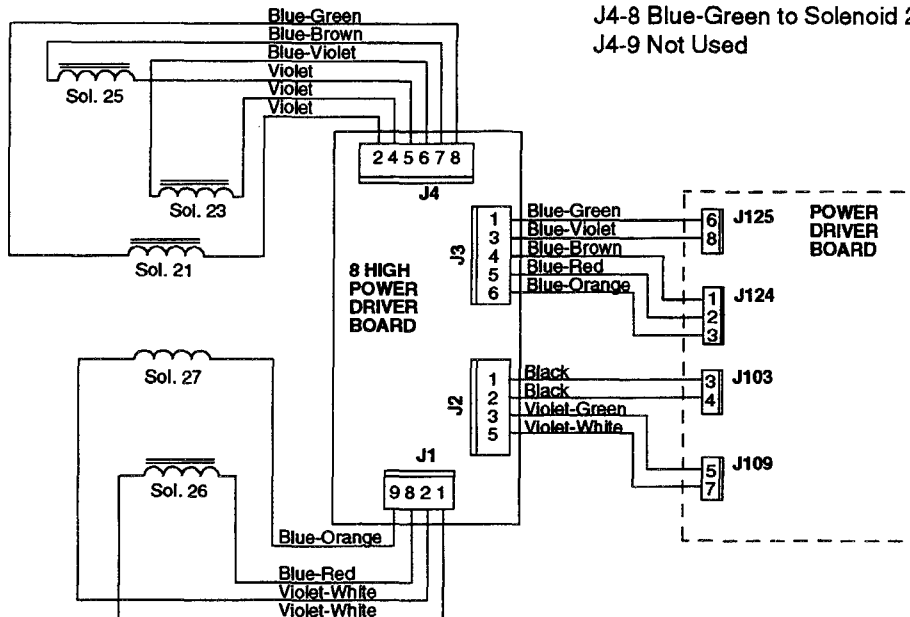

8 High Power Driver Schematic A-16116

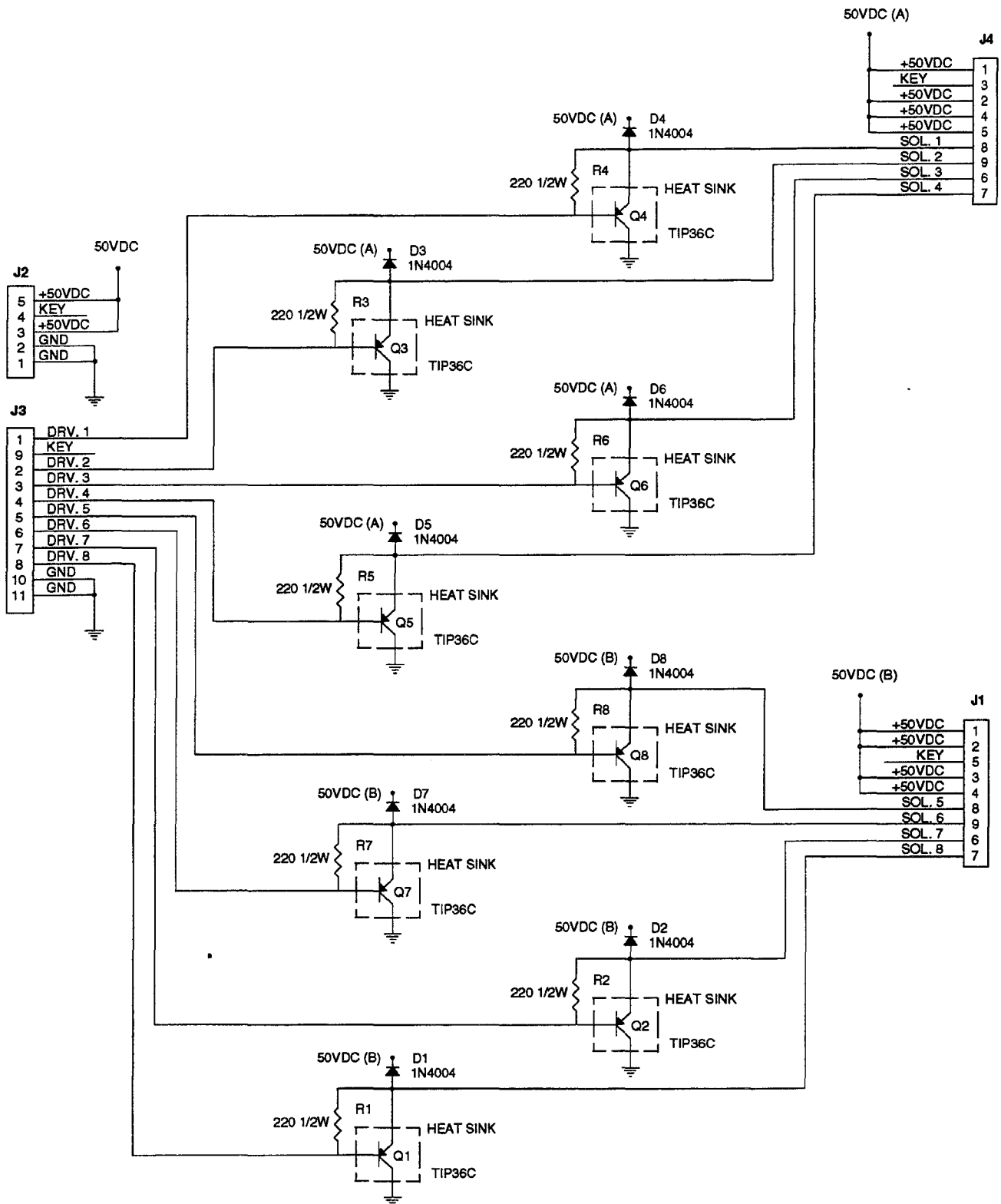

Custom Opto SW10 P.C.B. Assembly A-16807

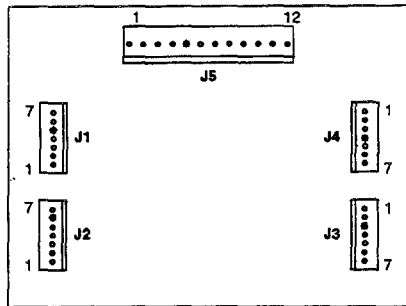

J1-1 Gray, to Photo Transistor Board Collector
 J1-2 Orange-Red, Switch #72 to Photo Transistor Board Emitter
 J1-3 Orange-Black, Switch #73 to Photo Transistor Board Emitter
 J1-4 Orange-Yellow, Switch #74 to Photo Transistor Board Emitter
 J1-5 Key
 J1-6 Orange-Green, Switch #75 to Photo Transistor Board Emitter
 J1-7 Orange-Blue, Switch #76 to Photo Transistor Board Emitter

J4-1 Gray, to Photo Transistor Board Collector
 J4-2 Orange-Brown, Switch #81 to Photo Transistor Board Emitter
 J4-3 Orange-Black, Switch #83 to Photo Transistor Board Emitter
 J4-4 Key
 J4-5 Orange-Yellow, Switch #84 to Photo Transistor Board Emitter
 J4-6 Orange-Green, Switch #85 to Photo Transistor Board Emitter
 J4-7 Orange-Violet, Switch #87 to Photo Transistor Board Emitter

J2-1 Gray-Red, Switch #72 to LED Board Anode
 J2-2 Gray-Orange, Switch #73 to LED Board Anode
 J2-3 Gray-Yellow, Switch #74 to LED Board Anode
 J2-4 Gray-Green, Switch #75 to LED Board Anode
 J2-5 Gray-Blue, Switch #76 to LED Board Anode
 J2-6 Key
 J2-7 Black, Ground to LED Board Anode

J5-1 Black, Ground from J118-3
 J5-2 Gray-Yellow, +12VDC from J118-2
 J5-3 Green-Gray from J206-9
 J5-4 Green-Violet from J206-7
 J5-5 Key
 J5-6 White-Violet from J208-8
 J5-7 White-Blue from J208-7
 J5-8 White-Green from J208-5
 J5-9 White-Yellow from J208-4
 J5-10 White-Orange from J208-3
 J5-11 White-Red from J208-2
 J5-12 White-Brown from J208-1

J3-1 Gray-Brown, Switch #81 to LED Board Anode
 J3-2 Gray-Orange, Switch #83 to LED Board Anode
 J3-3 Key
 J3-4 Gray-Yellow, Switch #84 to LED Board Anode
 J3-5 Gray-Green, Switch #85 to LED Board Anode
 J3-6 Gray-Violet, Switch #87 to LED Board Anode
 J3-7 Black, Ground to LED Board Anode

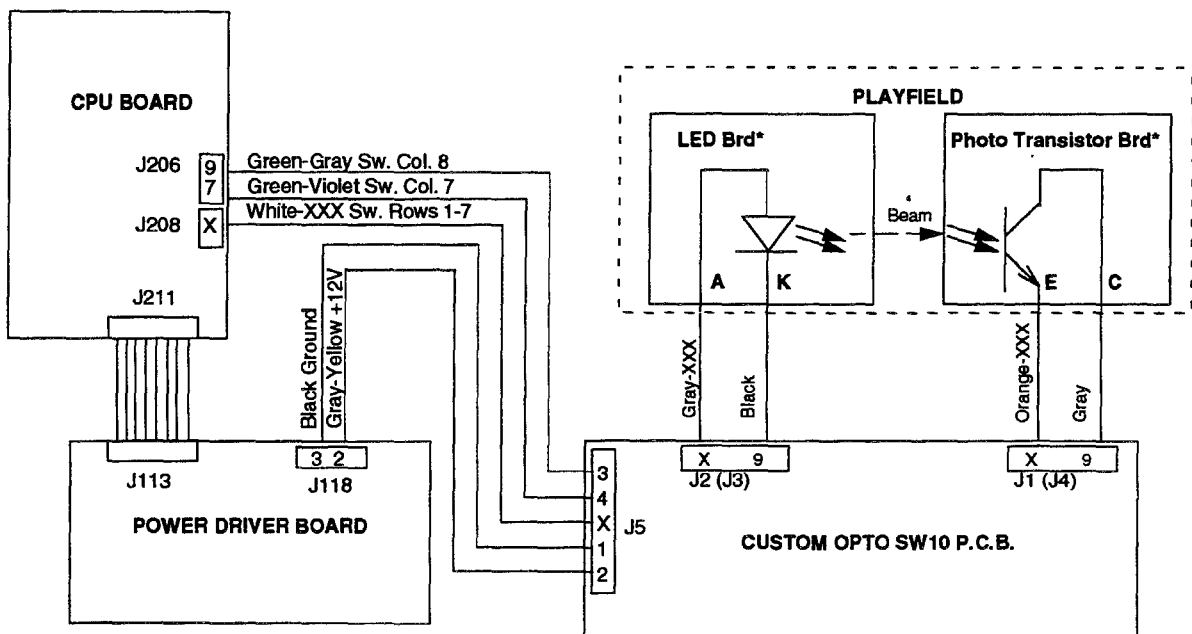

Custom Opto SW10 P.C.B. Schematic A-16807

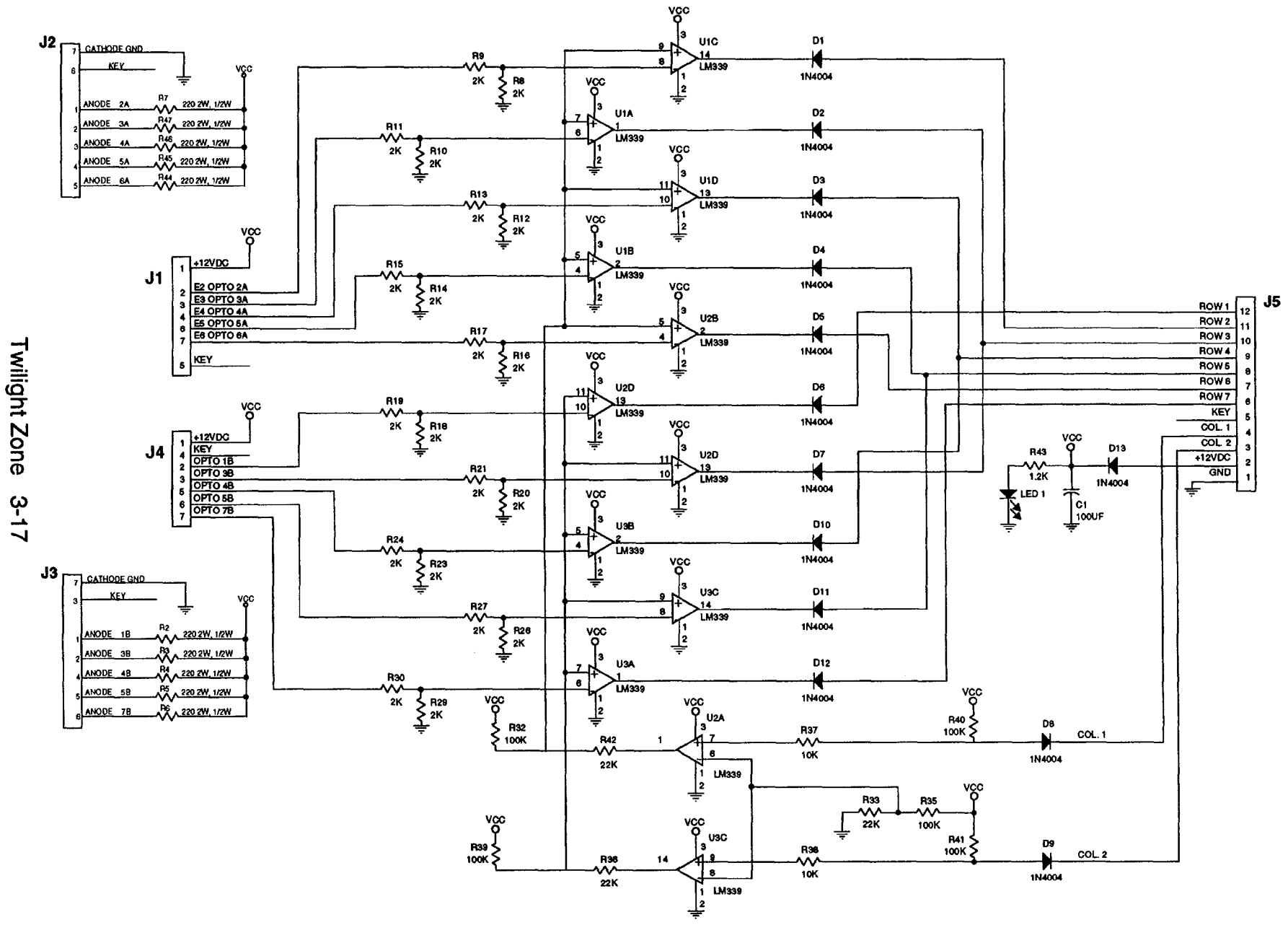

Twilight Zone 3-17

Minute Opto P.C.B. Assembly A-16220

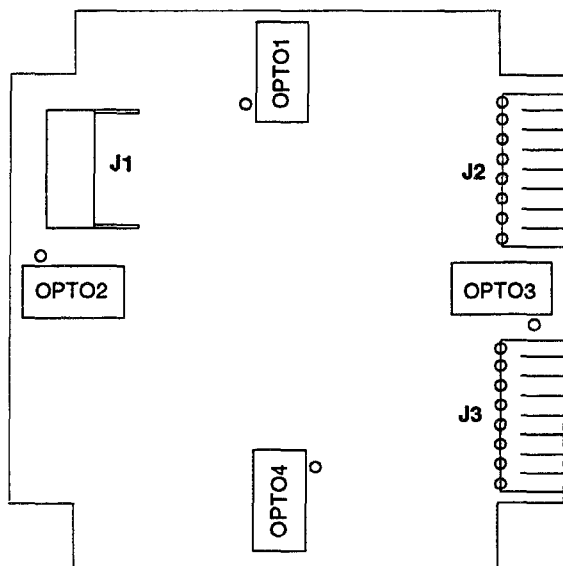

J1 from J1 on Hour Opto Bd., A-16219

- J2-1 Black-White
- J2-2 Gray-Yellow
- J2-3 Yellow-White
- J2-4 Yellow-White
- J2-5 Yellow
- J2-6 Yellow
- J2-7 Key
- J2-8 Gray-White

- J3-1 White-Yellow from J5-9, A-16807
- J3-2 White-Brown from J5-12, A-16807
- J3-3 White-Blue from J5-7, A-16807
- J3-4 White-Green from J5-8, A-16807
- J3-5 White-Violet from J5-6, A-16807
- J3-6 White-Gray
- J3-7 White-Red from J5-11, A-16807
- J3-8 White-Orange from J5-10, A-16807

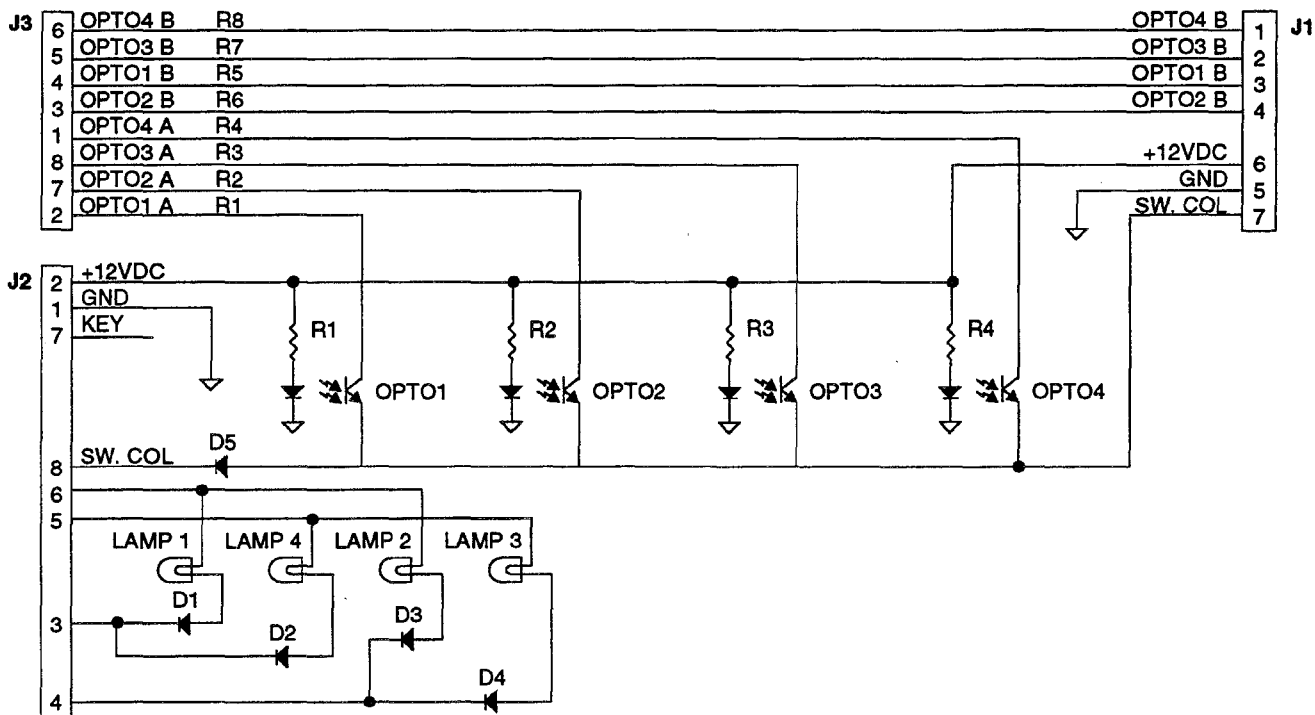

Hour Opto P.C.B. Assembly A-16219

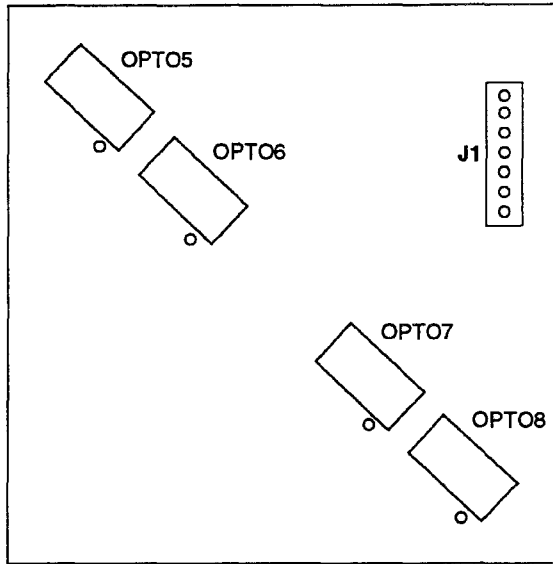

J1 to J1 on Minute Opto Bd., A-16220

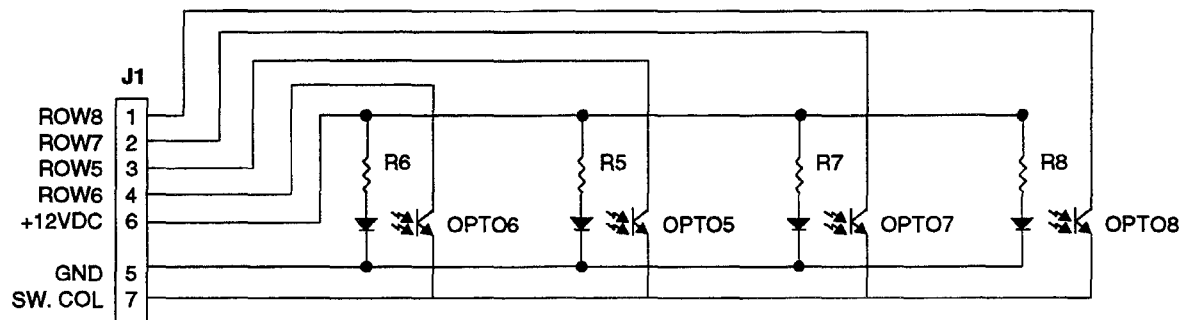

Ramp Proximity Opto Sensor Assembly A-16535

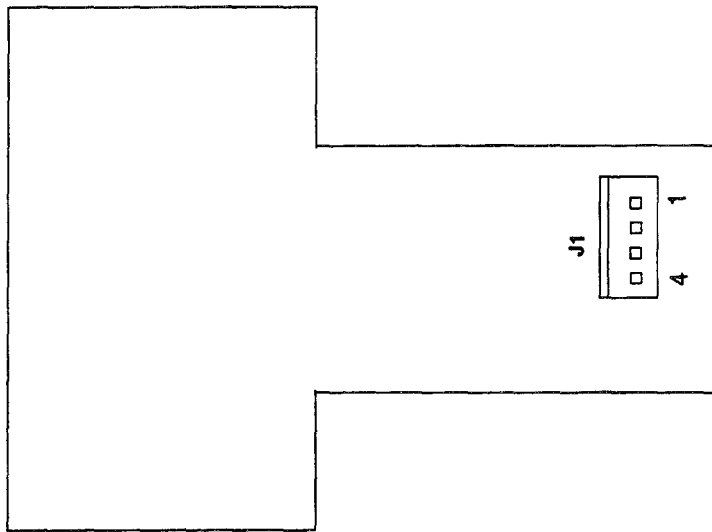

- J1-1 Black, Ground from J118-3
- J1-2 Gray-Yellow +12VDC from J118-2
- J1-3 Green-Black from J206-5
- J1-4 White-Violet from J208-8

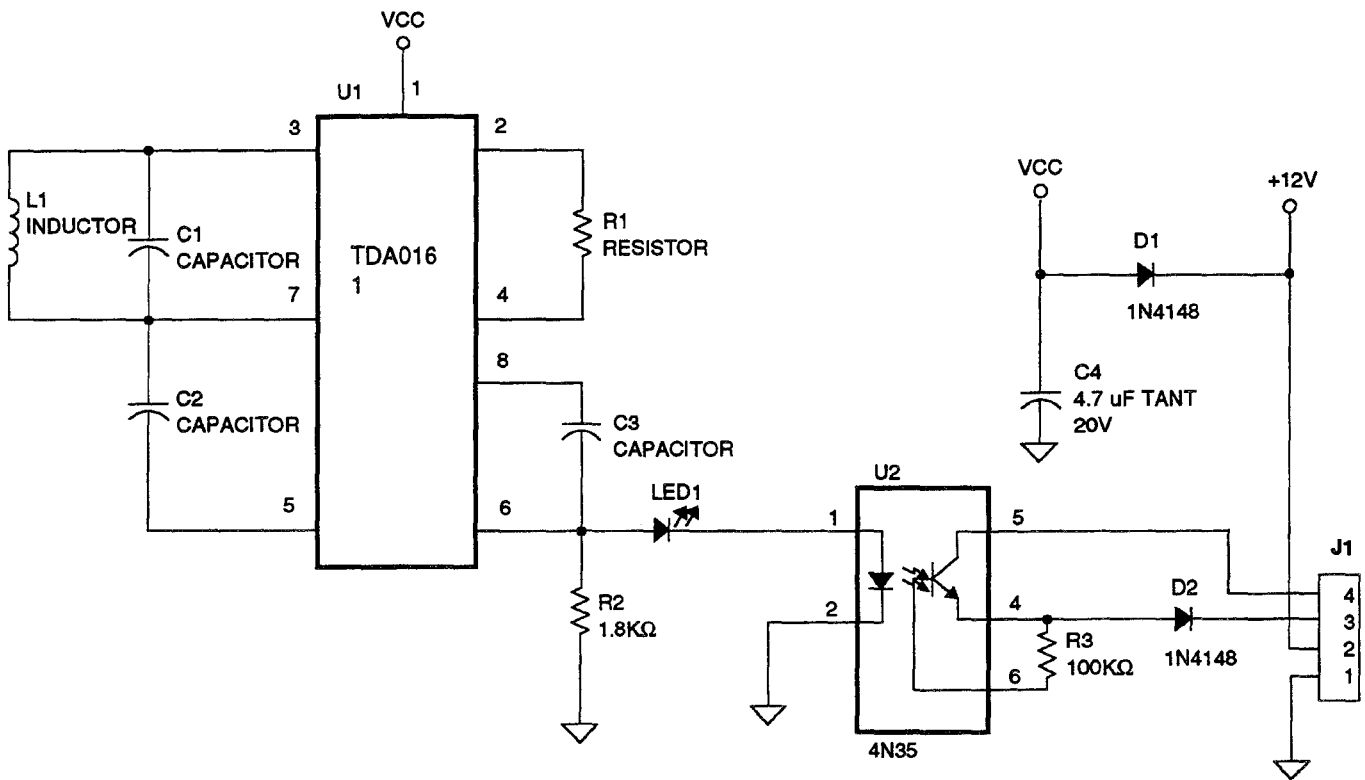

Proximity Sensor Board A-16534

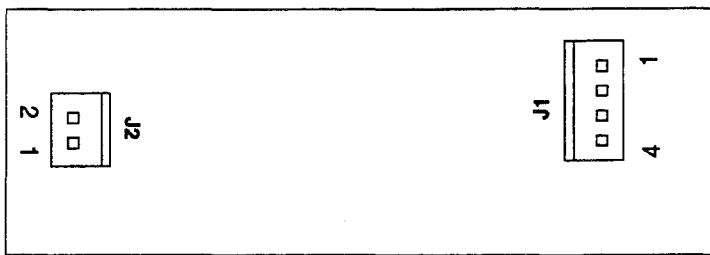

J1-1 Black, Ground from J118-3
 J1-2 Gray-Yellow, +12VDC from J118-2
 J1-3 Green-Red from J206-2
 J1-4 White-Blue from J208-7

J2-1 Red to J1-1, A-16528
 J2-2 Black to J1-3, A-16528

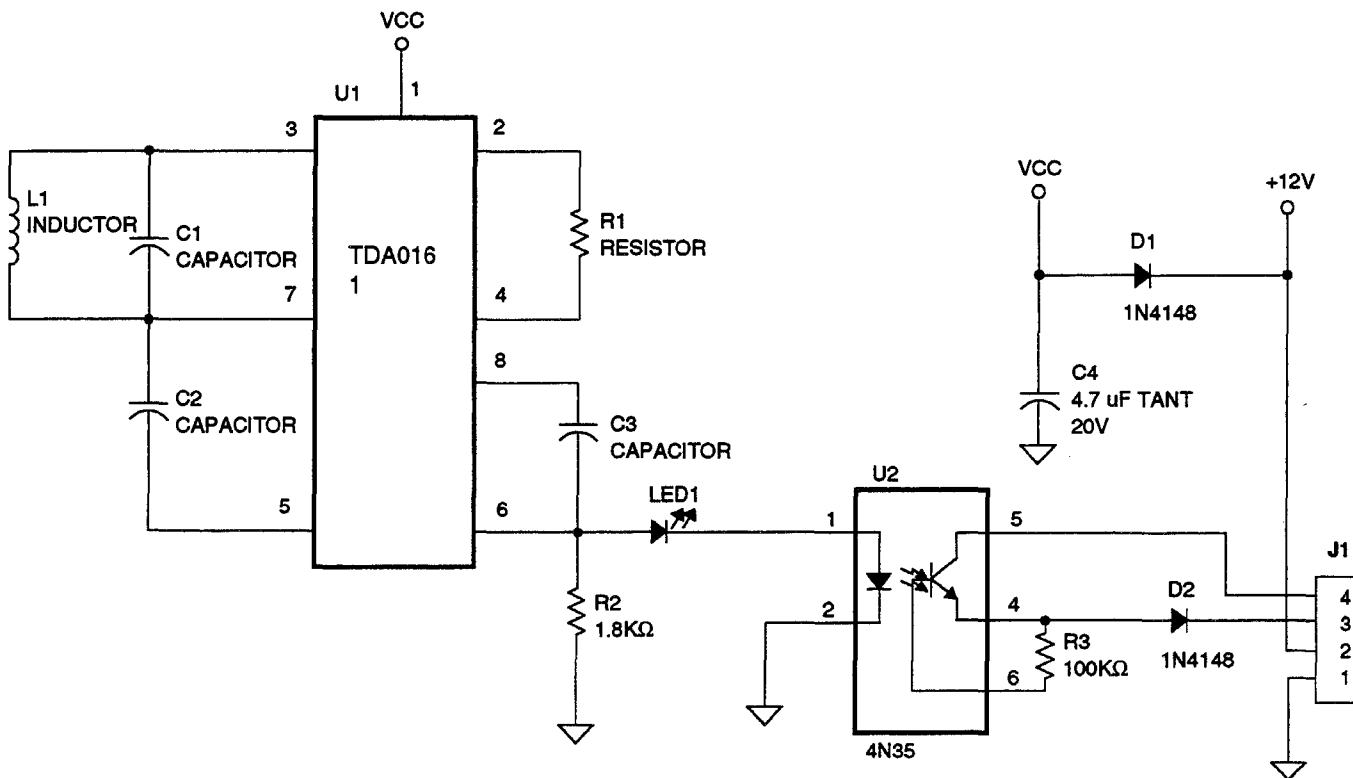

D.C. Motor Control Assembly (4 Way) A-16120

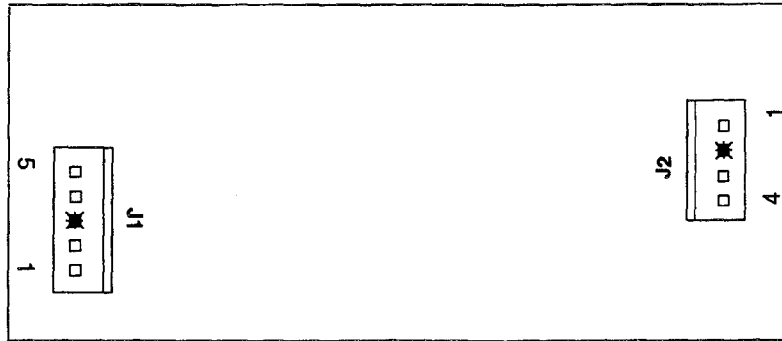

J1-1 Violet-White from J5-4, A-16100
 J1-2 Blue-White from J3-3, A-16100
 J1-3 Key
 J1-4 Black, Ground from J118-3
 J1-5 Gray-Yellow, +12VDC from J118-2

J2-1 Red, +20VDC to Clock Motor
 J2-2 Key
 J2-3 Not Used
 J2-4 Black, Ground to Clock Motor

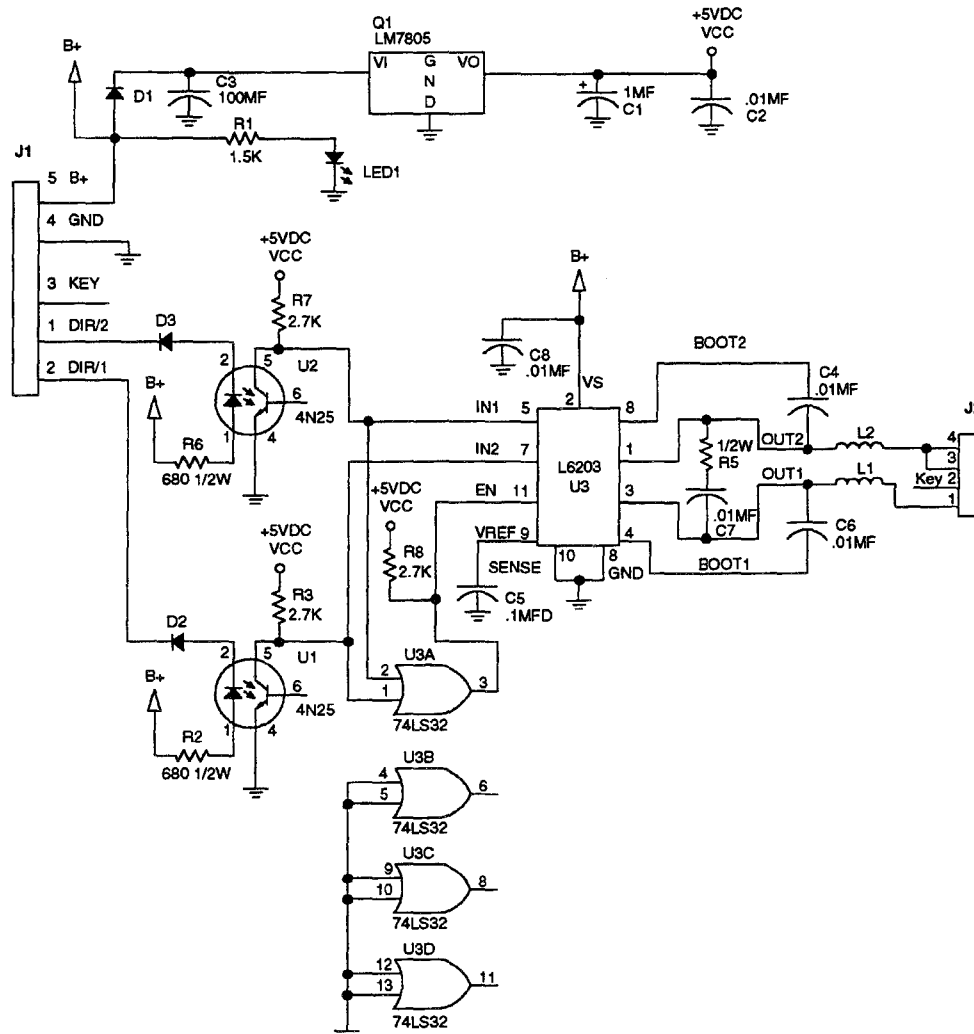

Motor EMI Board Assembly A-15542

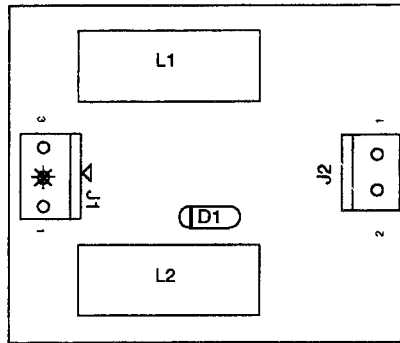

J1 - 1 Blue-Gray from J125-9
 J1 - 2 Key
 J1 - 3 Red from J107-5

J2 - 1 Red to Motor
 J2 - 2 Black, Ground to Motor

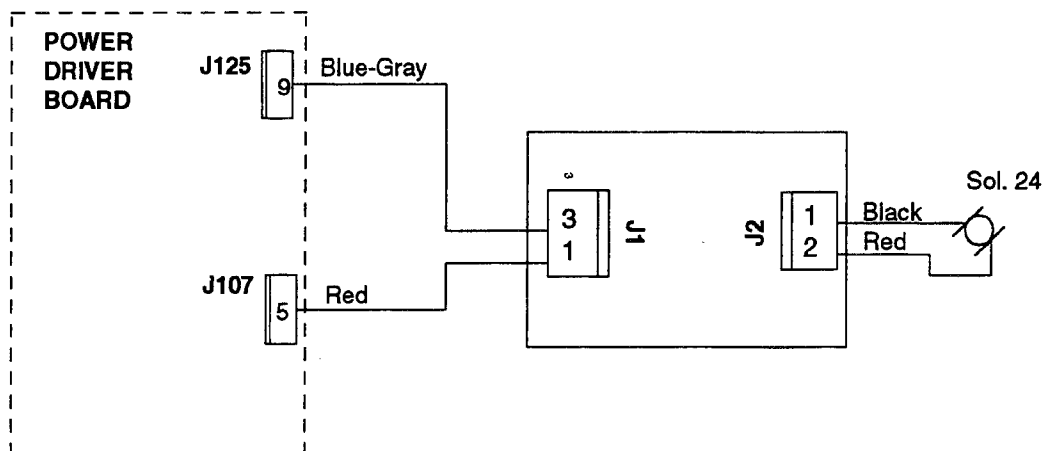
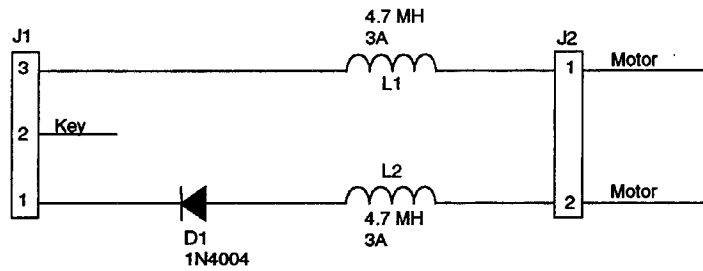

Flipper Opto Switch Board A-15894

Left Side Flipper Opto Switch Board

- J1 - 1 Blue-Gray (lower flipper) from Fliptronic II Board J905-2
- J1 - 2 Black-Blue (upper flipper) from Fliptronic II Board J905-5
- J1 - 3 Orange (Switch Grd) from Fliptronic II Board J905-6
- J1 - 4 Not Used
- J1 - 5 Key
- J1 - 6 Gray-Yellow (+12V) from Power Driver Board J116-2
- J1 - 7 Gray-Yellow (+12V) loop from J1-6

Right Side Flipper Opto Switch Board

- J1 - 1 Blue-Violet (lower flipper) from Fliptronic II Board J905-1
- J1 - 2 Black-Yellow (upper flipper) from Fliptronic II Board J905-3
- J1 - 3 Orange (Switch Grd) loop from Left Side Opto Board J1-4
- J1 - 4 Orange (Switch Grd) loop from J1-3
- J1 - 5 Key
- J1 - 6 Gray-Yellow (+12V) from Left Side Opto Board J1-7
- J1 - 7 Not Used

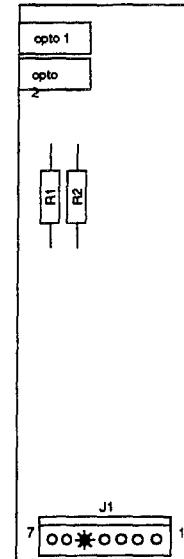

Please Note:

The Left Flipper Opto Switch Board must be connected in order for the Right Flipper Opto Switch Board to operate because power and ground are connected though the printed circuit board.

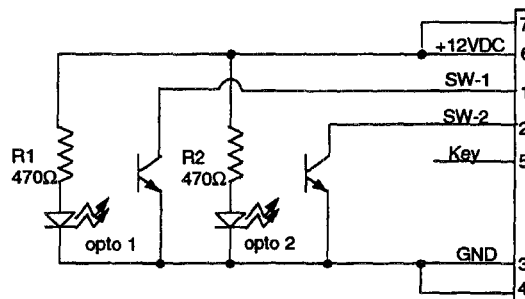

Flipper Circuit Diagram

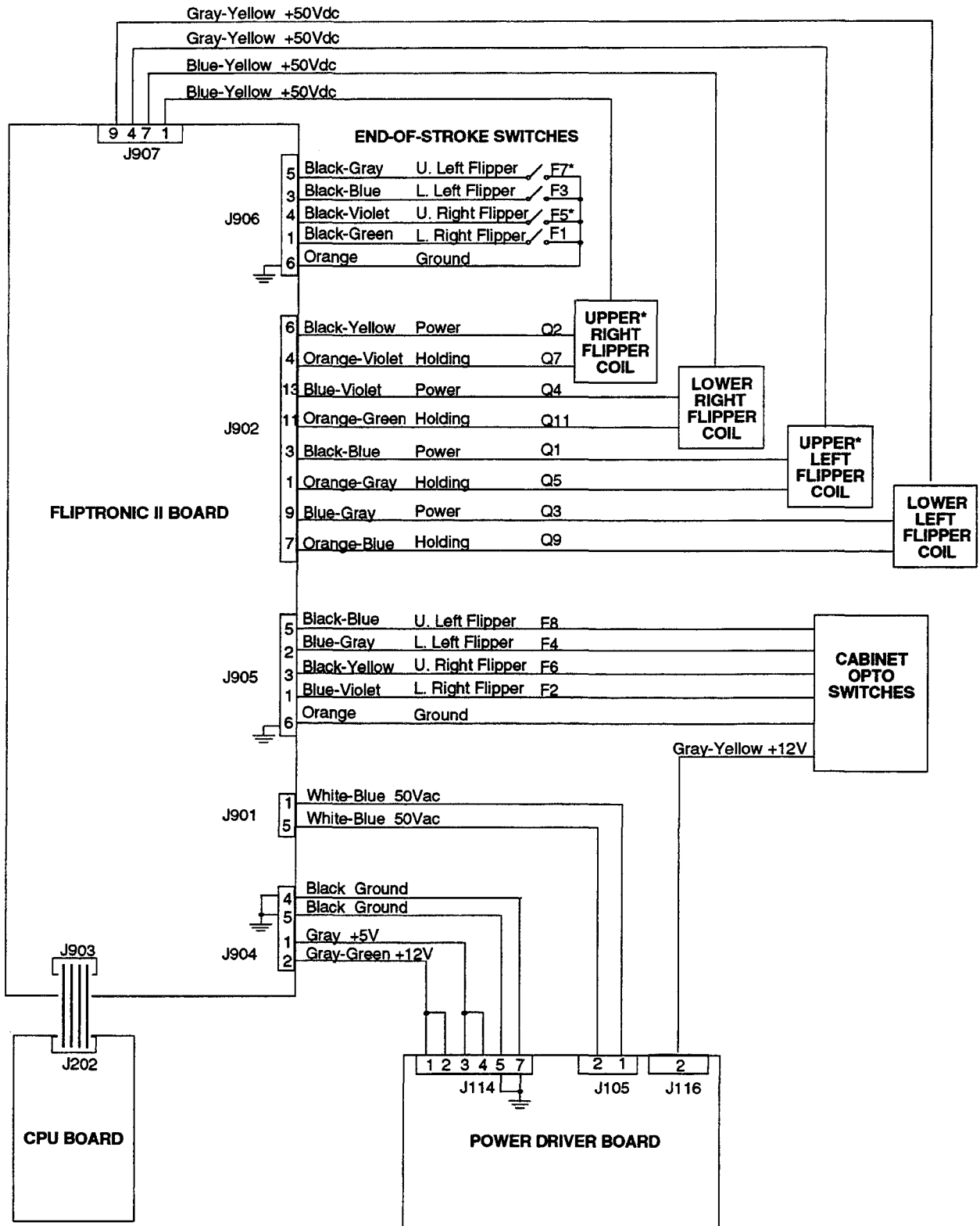

**Note: Used as circuits other than flipper circuits in this game.*

Flipper Coil Circuits

Left Flipper Circuit

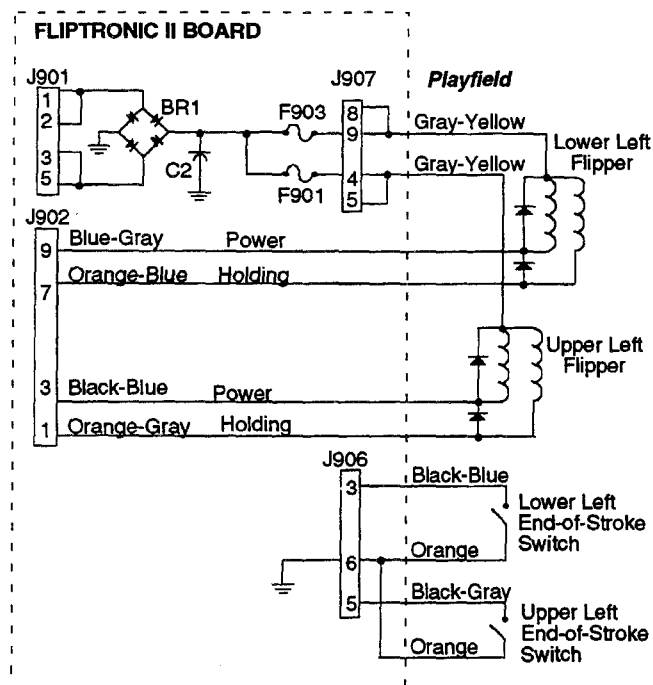

Right Flipper Circuit

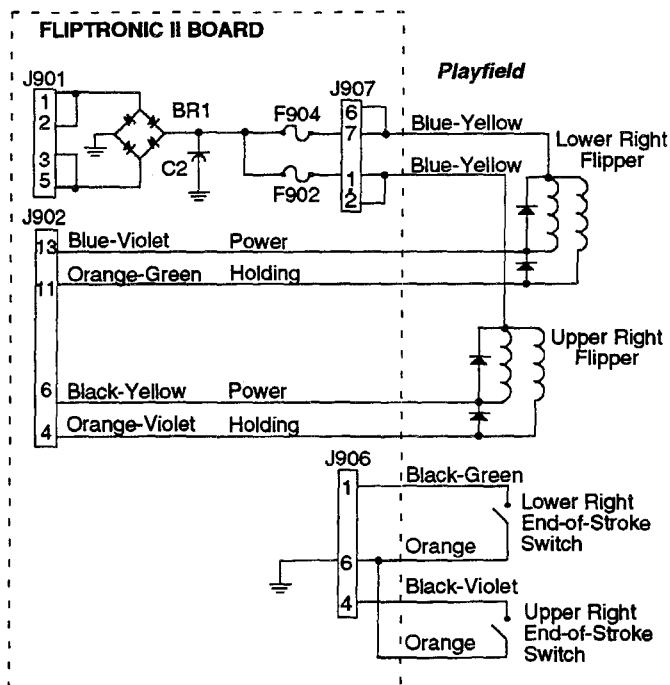

Flipper End-of-Stroke Switches

- F1 Lower Right Flipper
- F5 Upper Right Flipper
- F3 Lower Left Flipper
- F7 Upper Left Flipper

FLIPTRONIC II BOARD

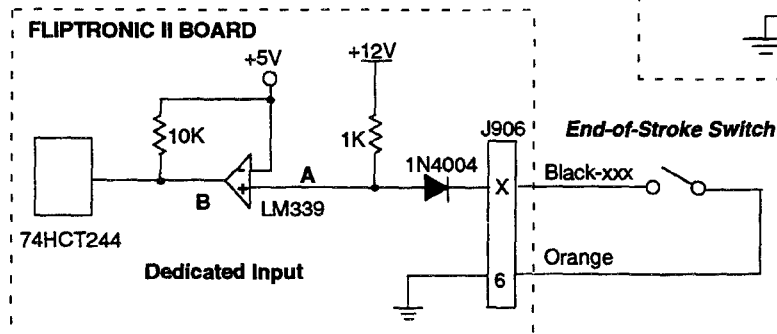
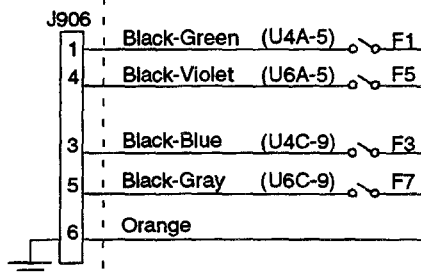

Switch	A	B	Off
Open	H	H	Off
Closed	L	L	On

The flipper switch circuits operate similar to the dedicated switch circuit. The circuits are active low and tied to ground through the switch.

When a switch closes the row side (dedicated input) of the circuit activates. The "+" input to the LM339 drops below +5V therefore its output is low. Since the row (dedicated input) circuit is tied directly to ground through the switch, the switch is considered closed by the microprocessor. When the switch opens, the "+" input to the LM339 is above +5V, its output is high and the row (dedicated input) is inactive.

Flipper Cabinet Switch Circuit Diagram

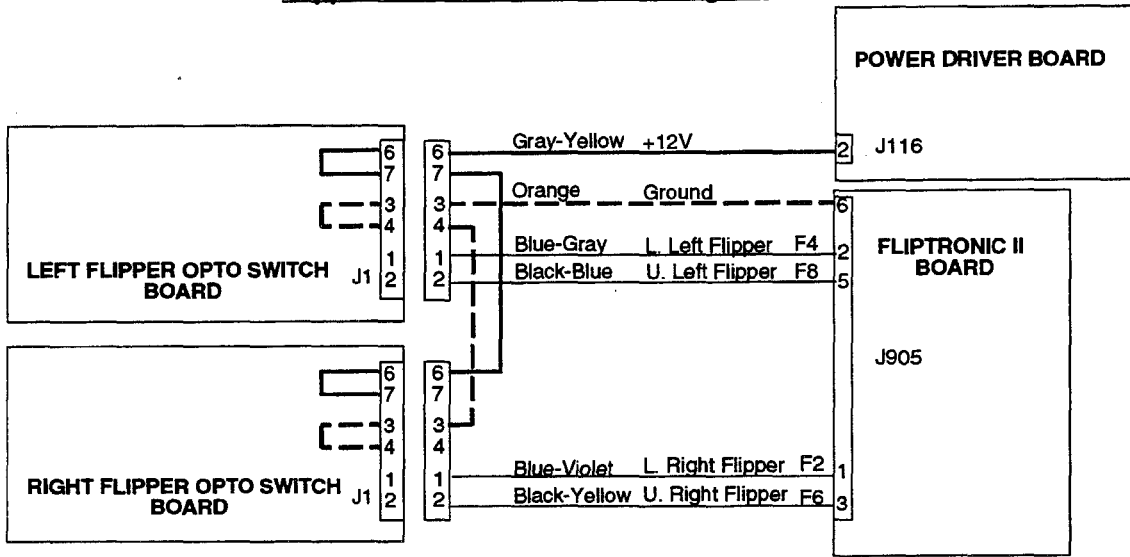

Flipper Cabinet Switches

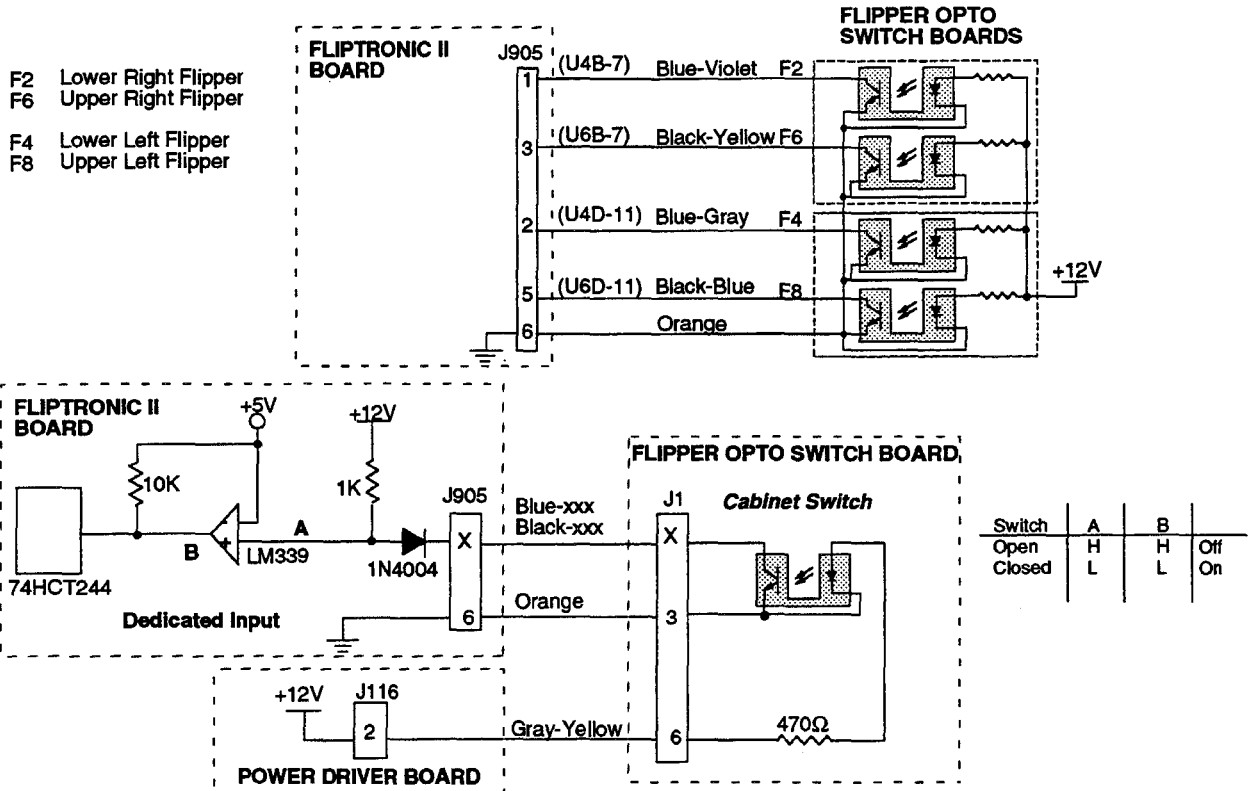

The flipper switch circuits operate similar to the dedicated switch circuit. The circuits are active low and tied to ground through the switch.

When a switch closes the row side (dedicated input) of the circuit activates. The "+" input to the LM339 drops below +5V therefore its output is low. Since the row (dedicated input) circuit is tied directly to ground through the switch, the switch is considered closed by the microprocessor. When the switch opens, the "+" input to the LM339 is above +5V, its output is high and the row (dedicated input) is inactive.

FLIPTRONIC II BOARD A-15472

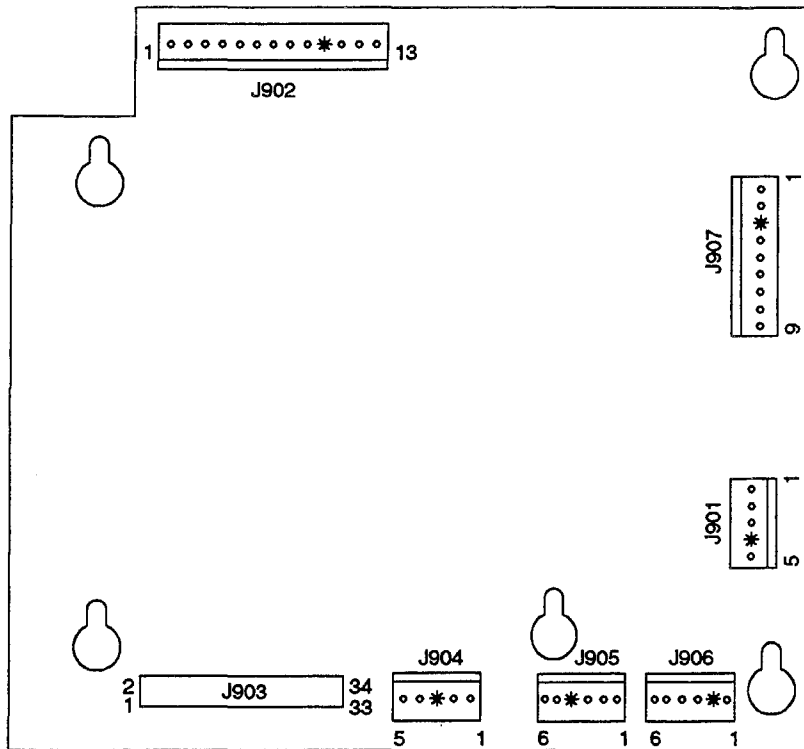

J901-1 White-Blue, 50VAC loop from J104-1
 J901-2 White-Blue, loop from J901-1
 J901-3 White-Blue, 50VAC loop, from J104-2
 J901-4 Key
 J901-5 White-Blue, loop from J901-3

J902-1 Orange-Gray, holding to upper left flipper
 J902-2 Not Used
 J902-3 Black-Blue, power to upper left flipper
 J902-4 Orange-Violet, holding to upper right flipper
 J902-5 Not Used
 J902-6 Black-Yellow, power to upper right flipper
 J902-7 Orange-Blue, holding to lower left flipper
 J902-8 Not Used
 J902-9 Blue-Gray, power to lower left flipper
 J902-10 Key
 J902-11 Orange-Green, holding to lower right flipper
 J902-12 Not Used
 J902-13 Blue-Violet, power to lower right flipper

J903 Ribbon Cable, data to/from J202; J506; J601

J904-1 Gray, +5V from J114-4
 J904-2 Gray-Green, +12V from J114-2
 J904-3 Key
 J904-4 Black, Ground from J114-7
 J904-5 Black, Ground from J114-5

J905-1 Blue-Violet, to right flipper opto
 J905-2 Blue-Gray, to left flipper opto
 J905-3 Black-Yellow, to right flipper opto
 J905-4 Key
 J905-5 Black-Blue, to left flipper opto
 J905-6 Orange, Switch Ground

J906-1 Black-Green, to lower right end-of-stroke switch
 J906-2 Key
 J906-3 Black-Blue, to lower left end-of-stroke switch
 J906-4 Black-Violet, to upper right end-of-stroke switch
 J906-5 Black-Gray, to upper left end-of-stroke switch
 J906-6 Orange, Switch Ground

J907-1 Blue-Yellow, +50V to lower right flipper
 J907-2 Blue-Yellow, loop from J907-1
 J907-3 Key
 J907-4 Gray-Yellow, +50V to lower left flipper
 J907-5 Gray-Yellow, loop from J907-4
 J907-6 Blue-Yellow, +50V to upper right flipper
 J907-7 Blue-Yellow, loop from J907-6
 J907-8 Gray-Yellow, loop from J907-9
 J907-9 Gray-Yellow, +50V to upper left flipper

P.C. Board Legend

J1-J6	Coin Door Interface Board
J1xx	Power Driver Board
J2xx	CPU Board
J5xx	Audio Board
J6xx	Dot Matrix Controller Board
J9xx	Fliptronic II Board

CPU BOARD A-12742-50020

J201 Ribbon Cable, Data to J602

J202 Ribbon Cable, Data to J903; J506; J601

J203 Not Used

J204 Ribbon Cable, Data to J1, A-16100

J205-1 Orange-Brown, Dir Sw 1, Left Coin to J1-14

J205-2 Orange-Red, Dir Sw 2, Center Coin to J1-13

J205-3 Orange-Black, Dir Sw 3, Right Coin to J1-12

J205-4 Orange-Yellow, Dir Sw 4, 4th Coin J1-17

J205-5 Key

J205-6 Orange-Green, Dir Sw 5, Escape/Service to J1-11

J205-7 Orange-Blue, Dir Sw 6, Down/Volume Down to J1-10

J205-8 Orange-Violet, Dir Sw 7, Up/Volume Up to J1-9

J205-9 Orange-Gray, Dir Sw 8, Enter/Test to J1-8

J205-10 Black, Ground to J1-15

J205-11 Not Used

J205-12 Orange-White, Enable to J1-18

J206-1 Green-Brown, Sw Col 1 to Playfield Switches

J206-2 Green-Red, Sw Col 2 to Playfield Switches

J206-3 Green-Orange, Sw Col 3 to Playfield Switches

J206-4 Green-Yellow, Sw Col 4 to Playfield Switches

J206-5 Green-Black, Sw Col 5 to Playfield Switches

J206-6 Green-Blue, Sw Col 6 to Playfield Switches

J206-7 Green-Violet, Sw Col 7 to Playfield Switches

J206-8 Key

J206-9 Green-Gray, Sw Col 8 to Playfield Switches

J207 Not Used

J208-1 White-Brown, Sw Row 1 to Playfield Switches

J208-2 White-Red, Sw Row 2 to Playfield Switches

J208-3 White-Orange, Sw Row 3 to Playfield Switches

J208-4 White-Yellow, Sw Row 4 to Playfield Switches

J208-5 White-Green, Sw Row 5 to Playfield Switches

J208-6 Key

J208-7 White-Blue, Sw Row 6 to Playfield Switches

J208-8 White-Violet, Sw Row 7 to Playfield Switches

J208-9 White-Gray, Sw Row 8 to Playfield Switches

J209 Not Used

J210-1 Black, Ground from J114-7

J210-2 Key

J210-3 Black, Ground from J114-5

J210-4 Gray, +5VDC from J114-4

J210-5 Gray, +5VDC from J114-3

J210-6 Gray-Green, +12VDC from J114-2

J210-7 Gray-Green, +12VDC from J114-1

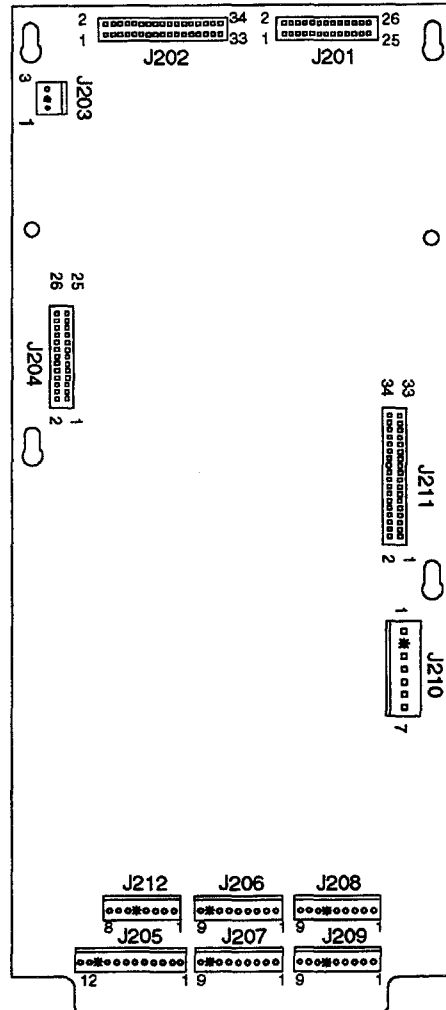

J211 Ribbon Cable, Data from J113

J212-1 Green-Brown, Sw Col 1 to J1-1

J212-2 Green-Red, Sw Col 2 to J1-7

J212-3 Not Used

J212-4 White-Brown, Sw Row 1 to J1-6

J212-5 Key

J212-6 White-Red, Sw Row 2 to J1-5

J212-7 White-Orange, Sw Row 3 to J1-4

J212-8 White-Yellow, Sw Row 4 to J1-3

P.C. Board Legend

J1-J6	Coin Door Interface Board
J1xx	Power Driver Board
J2xx	CPU Board
J5xx	Audio Board
J6xx	Dot Matrix Controller Board
J9xx	Flitronic II Board

COIN DOOR INTERFACE BOARD A-14689

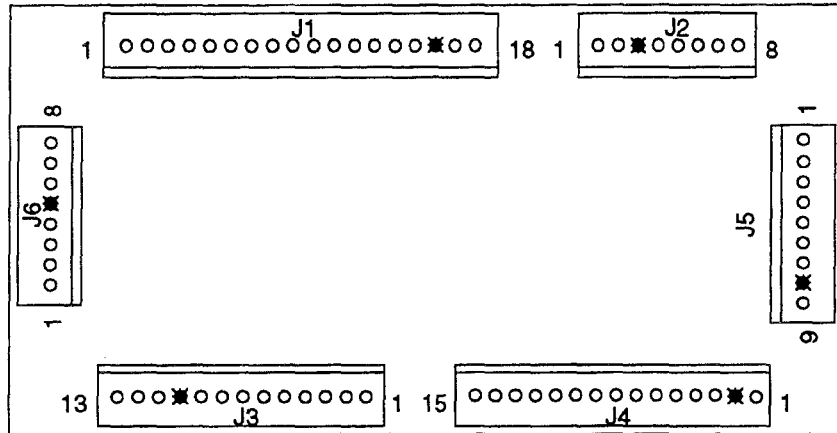

- J1-1 Green-Brown, switch column 1 from J212-1
- J1-2 Red-Gray, lamp row 8 from J134-9
- J1-3 White-Yellow, switch row 4 from J212-8
- J1-4 White-Orange, switch row 3 from J212-7
- J1-5 White-Red, switch row 2 from J212-6
- J1-6 White-Brown, switch row 1 from J212-4
- J1-7 Green-Red, switch column 2 from J212-2
- J1-8 Orange-Gray, dedicated switch row 8 from J205-9
- J1-9 Orange-Violet, dedicated switch row 7 from J205-8
- J1-10 Orange-Blue, dedicated switch row 6 from J205-7
- J1-11 Orange-Green, dedicated switch row 5 from J205-6
- J1-12 Orange-Black, dedicated switch row 3 from J205-3
- J1-13 Orange-Red, dedicated switch row 2 from J205-2
- J1-14 Orange-Brown, dedicated switch row 1 from J205-1
- J1-15 Black, Ground from J205-10
- J1-16 Key
- J1-17 Orange-Yellow, dedicated switch row 4 from J205-4
- J1-18 Orange-White, switch enable from J205-12

- J2-1 Violet, G.I. return from J119-3
- J2-2 White-Violet, G.I. 6.8VAC from J119-1
- J2-3 Key
- J2-4 Gray-Yellow, +12V from J116-2
- J2-5 Black, Ground from J116-3
- J2-6 Not Used
- J2-7 Not Used
- J2-8 Not Used

- J3-1 Violet, G.I. return to coin door
- J3-2 White-Violet, G.I. 6.8VAC to coin door
- J3-3 Black, Ground to coin door
- J3-4 Orange-Brown, dedicated switch row 1 to coin door
- J3-5 Orange-Red, dedicated switch row 2 to coin door
- J3-6 Orange-Black, dedicated switch row 3 to coin door
- J3-7 Orange-Green, dedicated switch row 4 to coin door
- J3-8 Orange-Blue, dedicated switch row 6 to coin door
- J3-9 Orange-Violet, dedicated switch row 7 to coin door
- J3-10 Key
- J3-11 Orange-Gray, dedicated switch row 8 to coin door
- J3-12 Green-Red, switch column 8 to coin door
- J3-13 White-Brown, switch row 1 to coin door

- J4 Not Used
- J5 Not Used

- J6-1 White-Red, switch row 2 to cabinet
- J6-2 White-Orange, switch row 3 to cabinet
- J6-3 White-Yellow, switch row 4 to cabinet
- J6-4 Red-Gray, lamp row 8 to cabinet
- J6-5 Key
- J6-6 Green-Red, switch column 2 to cabinet
- J6-7 Green-Brown, switch column 1 to cabinet
- J6-8 Green-Brown, switch column 1 to cabinet

P.C. Board Legend

J1-J6	Coin Door Interface Board
J1xx	Power Driver Board
J2xx	CPU Board
J5xx	Audio Board
J6xx	Dot Matrix Controller Board
J9xx	Fliptronic II Board

Coin Door Interface Board Schematic A-14689

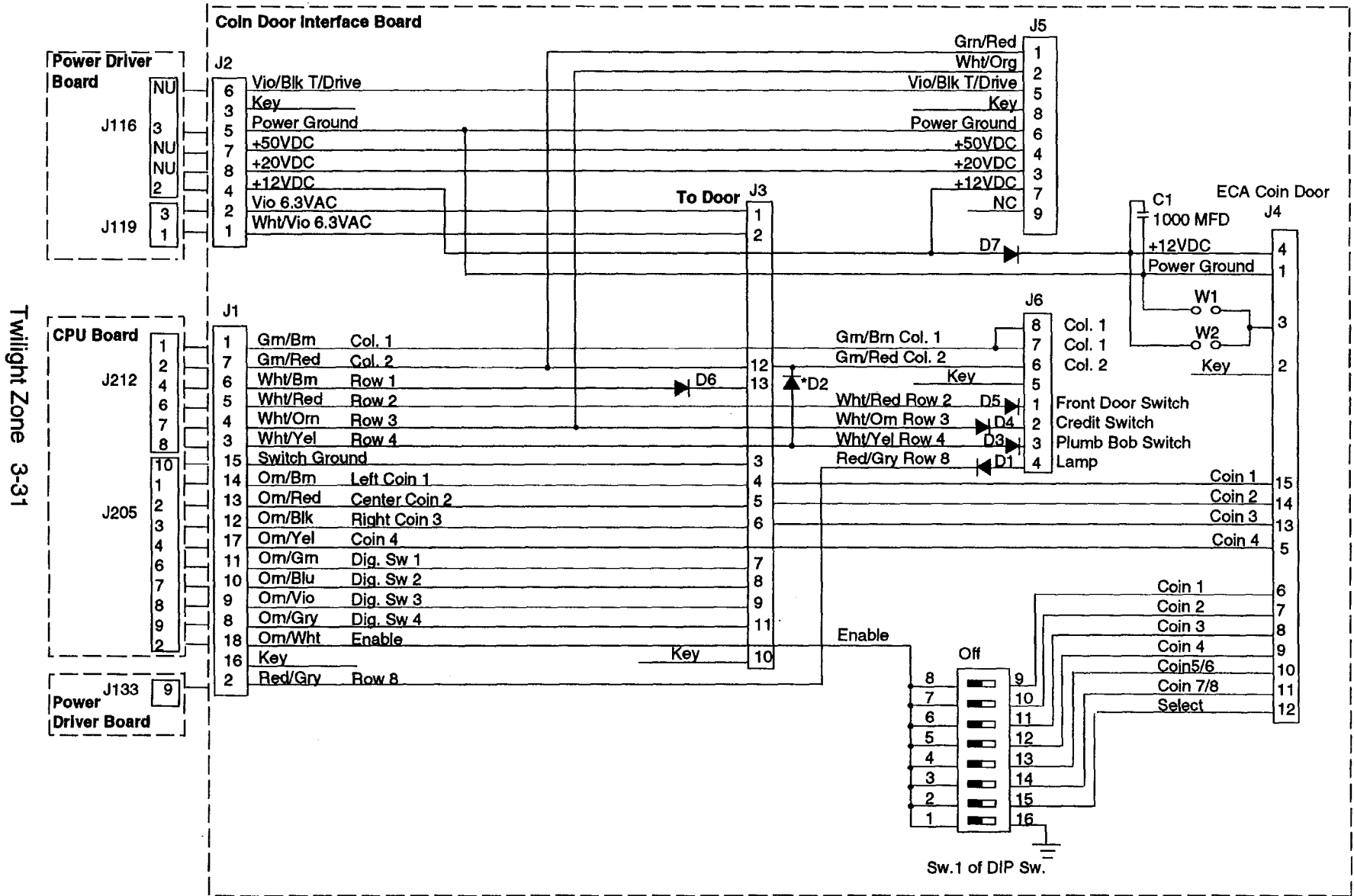

*Switch 24, always closed

Twilight Zone 3-31

POWER DRIVER BOARD A-12697-3

J101-1 Red, 9VAC from transformer secondary
 J101-2 Red, 9VAC from transformer secondary
 J101-3 Key
 J101-4 Blue-White, 13VAC from transformer secondary
 J101-5 Blue-White, loop from J101-4
 J101-6 Blue-White, 13VAC from transformer secondary
 J101-7 Blue-White, loop from J101-6

J102-1 White-Red, loop from J102-2
 J102-2 White-Red, 16VAC from transformer secondary
 J102-3 White-Red, loop from J102-4
 J102-4 White-Red, 16VAC from transformer secondary
 J102-5 Black-Yellow, loop from J102-6
 J102-6 Black-Yellow, 16VAC from transformer secondary
 J102-7 Key
 J102-8 Black-Yellow, loop from J102-9
 J102-9 Black-Yellow, 16VAC from transformer secondary

J103-1 Black, Ground to J2-5, A-16100
 J103-2 Black, Ground to J2-4, A-16100
 J103-3 Black, Ground to J2-1, A-16116
 J103-4 Black, Ground to J2-2, A-16116

J104 Not Used

J105-1 White-Blue, 50VAC to J901-1
 J105-2 White-Blue, 50VAC to J901-3
 J105-3 Key
 J105-4 Not Used
 J105-5 Not Used

J106 Not Used

J107-1 Not Used
 J107-2 Violet-Orange, 50V to playfield coils
 J107-3 Violet-Yellow, 50V to playfield coils
 J107-4 Key
 J107-5 Red, +20V to playfield flashlamps
 J107-6 Red-White, +20V to playfield flashlamps

J108 Not Used

J109-1 Not Used
 J109-2 Not Used
 J109-3 Not Used
 J109-4 Not Used
 J109-5 Violet-Green, 50V to playfield coils
 J109-6 Key
 J109-7 Violet-White, 50V to playfield coils

J110 Not Used

J111 Not Used

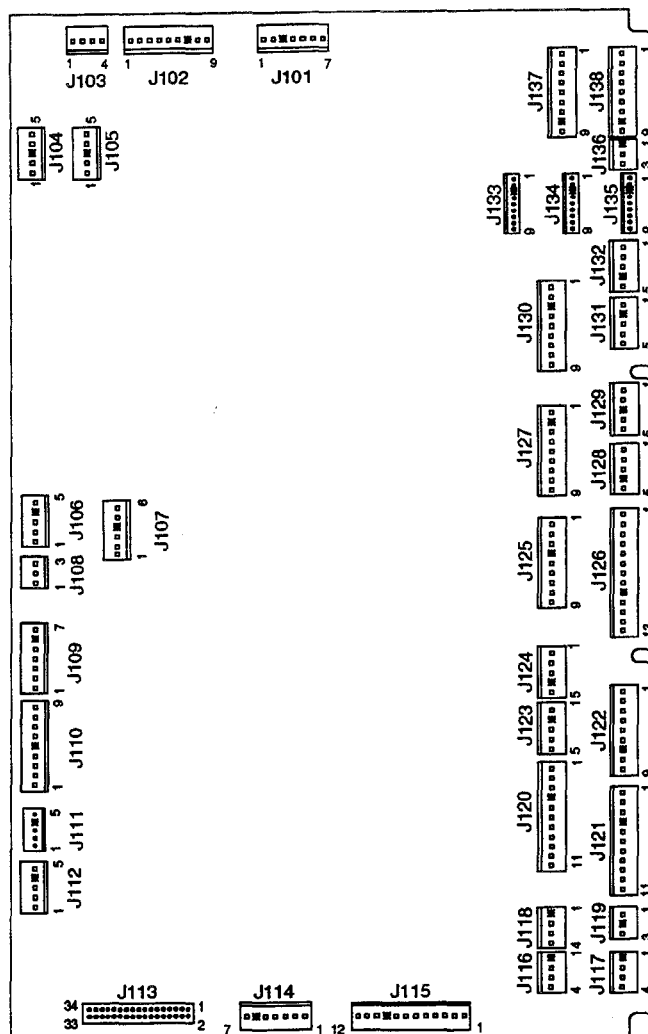

J112-1 White-Green, 9.8VAC from transformer secondary
 J112-2 White-Green, loop from J112-1
 J112-3 White-Green, 9.8VAC from transformer secondary
 J112-4 Key
 J112-5 White-Green, loop from J112-3

J113 Ribbon Cable, Data to/from J211

J114-1 Gray/Green, +12VDC to J210-7
 J114-2 Not Used
 J114-3 Gray, +5VDC to J210-5; J502-3
 J114-4 Not Used
 J114-5 Not Used
 J114-6 Key
 J114-7 Black, Ground to J210-1; J502-4; J904-4

P.C. Board Legend	
J1-J6	Coin Door Interface Board
J1xx	Power Driver Board
J2xx	CPU Board
J5xx	Audio Board
J6xx	Dot Matrix Controller Board
J9xx	Fliptronic II Board

POWER DRIVER BOARD CONTINUED...

<p>J115-1 Yellow-White, 6.8VAC from transformer secondary J115-2 White-Brown, 6.8VAC from transformer secondary J115-3 White-Brown, loop from J115-2 J115-4 White-Orange, 6.8VAC from transformer secondary J115-5 White-Yellow, loop from J115-6 J115-6 White-Yellow, 6.8VAC from transformer secondary J115-7 Orange, 6.8VAC from transformer secondary J115-8 Orange, 6.8VAC loop from J115-7 J115-9 Key J115-10 Green, 6.8VAC from transformer secondary J115-11 Brown, 6.8VAC from transformer secondary J115-12 Brown, 6.8VAC loop from J115-11</p> <p>J116-1 Key J116-2 Gray-Yellow, +12VDC to coin door; J2-4 J116-3 Black, Ground to coin door; J2-5 J116-4 Not Used</p> <p>J117-1 Key J117-2 Gray-Yellow, +12VDC to J606-7 J117-3 Black, Ground to J606-3 J117-4 Gray, +5VDC to J606-5</p> <p>J118-1 Key J118-2 Gray-Yellow, +12VDC playfield/cabinet J118-3 Black, Ground J118-4 Not Used</p> <p>J119-1 White-Violet, 6.8VAC G.I. to coin door; J2-2 J119-2 Key J119-3 Violet, Return G.I. to coin door; J2-1</p> <p>J120-1 Not Used J120-2 Orange, Return G.I. to insert J120-3 Yellow, Return G.I. to insert J120-4 Key J120-5 Green, Return G.I. to insert J120-6 Not Used J120-7 Not Used J120-8 White-Orange, 6.8VAC to insert J120-9 White-Yellow, 6.8VAC to insert J120-10 White-Green, 6.8VAC to insert J120-11 Not Used</p> <p>J121-1 Brown, Return G.I. to playfield J121-2 Orange, Return G.I. to playfield J121-3 Yellow, Return G.I. to playfield J121-4 Key J121-5 Not Used J121-6 Violet, Return G.I. to playfield J121-7 White-Brown, 6.8VAC to playfield J121-8 White-Orange, 6.8VAC to playfield J121-9 White-Yellow, 6.8VAC to playfield J121-10 Not Used J121-11 White-Violet, 6.8VAC to playfield</p>	<p>J122 Not Used</p> <p>J123 Not Used</p> <p>J124-1 Blue-Brown, Sol 25 to playfield magnet J124-2 Blue-Red, Sol 26 to playfield magnet J124-3 Blue-Orange, Sol 27 to playfield coil J124-4 Key J124-5 Blue-Yellow, Sol 28 to playfield flasher</p> <p>J125-1 Black-Brown, Sol 17 to playfield flasher J125-2 Black-Red, Sol 18 to playfield flasher J125-3 Black-Orange, Sol 19 to playfield flasher J125-4 Key J125-5 Black-Yellow, Sol 20 to playfield flasher J125-6 Blue-Green, Sol 21 to playfield magnet J125-7 Not Used J125-8 Blue-Violet, Sol 23 to playfield magnet J125-9 Blue-Gray, Sol 24 to playfield motor</p> <p>J126 Not Used</p> <p>J127-1 Brown-Black, Sol 9 to playfield coil J127-2 Key J127-3 Brown-Red, Sol 10 to playfield coil J127-4 Brown-Orange, Sol 11 to playfield coil J127-5 Brown-Yellow, Sol 12 to playfield coil J127-6 Brown-Green, Sol 13 to playfield coil J127-7 Brown-Blue, Sol 14 to playfield coil J127-8 Brown-Violet, Sol 15 to playfield coil J127-9 Brown-Gray, Sol 16 to playfield coil</p> <p>J128 Not Used</p> <p>J129 Not Used</p> <p>J130-1 Violet-Brown, Sol 1 to playfield coil J130-2 Violet-Red, Sol 2 to playfield coil J130-3 Key J130-4 Violet-Orange, Sol 3 to playfield coil J130-5 Violet-Yellow, Sol 4 to playfield coil J130-6 Violet-Green, Sol 5 to playfield coil J130-7 Violet-Blue, Sol 6 to playfield coil J130-8 Violet-Black, Sol 7 to playfield coil J130-9 Violet-Gray, Sol 8 to playfield coil</p> <p>J131 Not Used</p> <p>J132 Not Used</p>
---	--

P.C. Board Legend	
J1-J6	Coin Door Interface Board
J1xx	Power Driver Board
J2xx	CPU Board
J5xx	Audio Board
J6xx	Dot Matrix Controller Board
J9xx	Flitronic II Board

POWER DRIVER BOARD CONTINUED...

J133-1 Red-Brown, Row1 to playfield lamps
J133-2 Red-Black, Row2 to playfield lamps
J133-3 Key
J133-4 Red-Orange, Row3 to playfield lamps
J133-5 Red-Yellow, Row4 to playfield lamps
J133-6 Red-Green, Row5 to playfield lamps
J133-7 Red-Blue, Row6 to playfield lamps
J133-8 Red-Violet, Row7 to playfield lamps
J133-9 Red-Gray, Row 8 to playfield lamps

J134 Not Used

J135-1 Not Used
J135-2 Not Used
J135-3 Key
J135-4 Not Used
J135-5 Not Used
J135-6 Not Used
J135-7 Not Used
J135-8 Red-Violet, Row 7 to cabinet lamp
J135-9 Red-Gray, Row 8 to cabinet lamp

J136-1 Key
J136-2 Not Used
J136-3 Yellow/Gray , Col 8 to cabinet lamp

J137-1 Yellow-Brown, Col 1 to playfield lamps
J137-2 Yellow-Red, Col 2 to playfield lamps
J137-3 Yellow-Orange, Col 3 to playfield lamps
J137-4 Yellow-Black, Col 4 to playfield lamps
J137-5 Yellow-Green, Col 5 to playfield lamps
J137-6 Yellow-Blue, Col 6 to playfield lamps
J137-7 Yellow-Violet, Col 7 to playfield lamps
J137-8 Key
J137-9 Yellow-Gray, Col 8 to playfield lamps

J138 Not Used

P.C. Board Legend

J1-J6	Coin Door Interface Board
J1xx	Power Driver Board
J2xx	CPU Board
J5xx	Audio Board
J6xx	Dot Matrix Controller Board
J9xx	Fliptronic II Board

SOUND BOARD A-12738-50020

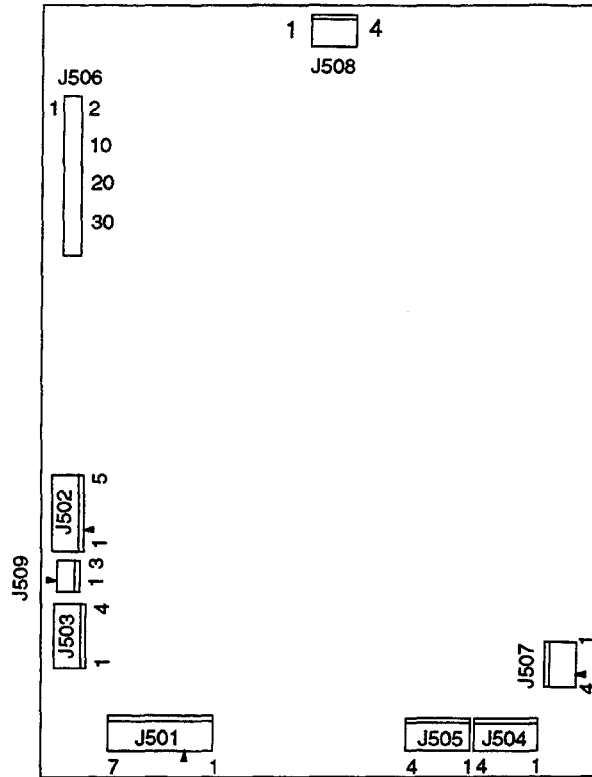

J501-1 Gray-Green, 20VAC from transformer secondary
 J501-2 Gray-Green, loop from J501-1
 J501-3 Key
 J501-4 Gray, 20VAC from transformer secondary
 J501-5 Gray, 20VAC loop from J501-4
 J501-6 Gray-White, 20VAC loop from transformer secondary
 J501-7 Gray-White, 20VAC loop from J501-6

J502-1 Gray, +5VDC from J114-4
 J502-2 Key
 J502-3 Gray, +5VDC from J114-3
 J502-4 Black, Ground from J114-7
 J502-5 Black, Ground from J114-5

J503 Not Used

J504-1 Not Used
 J504-2 Not Used
 J504-3 Black, Signal to speaker
 J504-4 Not Used

J505-1 Not Used
 J505-2 Black-Yellow, Signal to speaker
 J505-3 Not Used
 J505-4 Not Used

J506 Ribbon Cable, Data to/from J601; J903; J202

J507 Not Used

J508 Not Used

J509 Not Used

P.C. Board Legend

J1-J6	Coin Door Interface Board
J1xx	Power Driver Board
J2xx	CPU Board
J5xx	Audio Board
J6xx	Dot Matrix Controller Board
J9xx	Fliptronic II Board

DOT MATRIX CONTROLLER BOARD A-14039

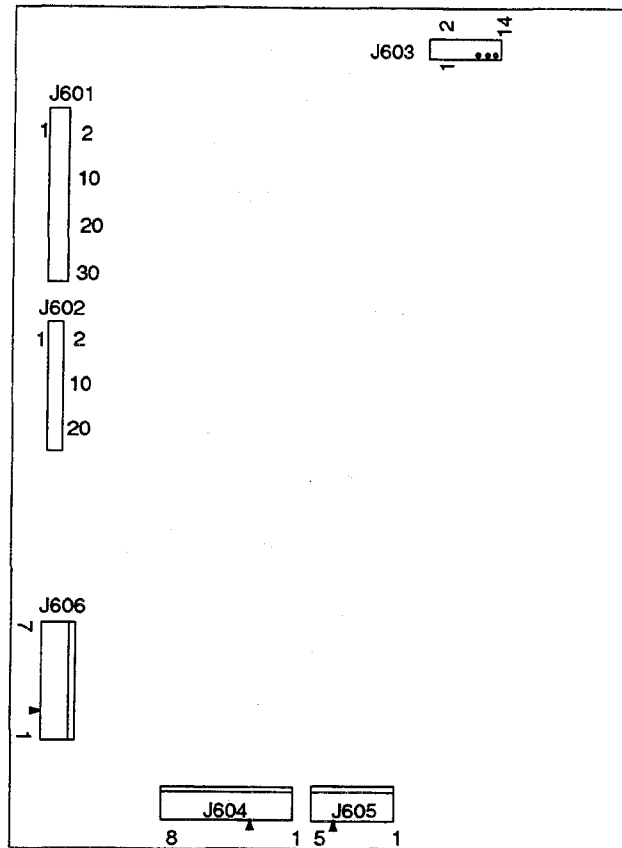

J601 Ribbon Cable, Data to/from J202; J903; J506

J602 Ribbon Cable, Data from J201

J603 Ribbon Cable, Data to Dot Matrix Display Driver

J604-1 Orange, -125V to Dot Matrix Display Driver Pin 1

J604-2 Blue, -113V to Dot Matrix Display Driver Pin 2

J604-3 Key

J604-4 Black, Ground to Dot Matrix Display Driver Pin 4

J604-5 Black, Ground to Dot Matrix Display Driver Pin 5

J604-6 Gray, +5V to Dot Matrix Display Driver Pin 6

J604-7 Gray-Yellow, +12V to Dot Matrix Display Driver Pin 7

J604-8 Brown, +62 to Dot Matrix Display Driver Pin 8

J605-1 White, 80VAC from transformer secondary

J605-2 White, 80VAC from transformer secondary

J605-3 Violet, 100VAC from transformer secondary

J605-4 Key

J605-5 Violet, 100VAC from transformer secondary

J606-1 Black, Ground loop from J606-3

J606-2 Key

J606-3 Black, Ground from J117-3

J606-4 Gray, +5V loop from J606-5

J606-5 Gray, +5V from J117-4

J606-6 Gray-Yellow, +12V loop from J606-7

J606-7 Gray-Yellow, +12V from J117-2

P.C. Board Legend

J1-J6	Coin Door Interface Board
J1xx	Power Driver Board
J2xx	CPU Board
J5xx	Audio Board
J6xx	Dot Matrix Controller Board
J9xx	Flitronic II Board

LAMPS

Yellow (B+) Red

Column \ Row	1 Yellow-Brown J137-1 Q88	2 Yellow-Red J137-2 Q87	3 Yellow-Orange J137-3 Q96	4 Yellow-Black J137-4 Q95	5 Yellow-Green J137-5 Q94	6 Yellow-Blue J137-6 Q93	7 Yellow-Violet J138-7 Q92	8 Yellow-Gray J138-9 Q91
1 Red-Brown J133-1 Q90	Camera (Door) 11	Door Panel "Lock 2" 21	Left Extra Ball 31	Spiral "2 Million" 41	Left Ramp Bonus X 51	Left Jet Bumper 61	Lower Right 5 Million 71	Left Spiral 81
2 Red-Black J133-2 Q89	Hitch Hicker (Door) 12	Greed (Door) 22	Door Panel "Lock 1" 32	Spiral Left Battle Power 42	Left Ramp Multiball 52	Lower Jet Bumper 62	Middle Right 5 Million 2 72	Clock Millions 82
3 Red-Orange J133-4 Q88	Clock Chaos (Door) 13	10 Million (Door) 23	Left Inlane 1 33	Spiral "4 Million" 43	Left Ramp "Super Skill" 53	Right Jet Bumper 63	Middle Right 5 Million 1 73	Piano Yellow 83
4 Red-Yellow J133-5 Q87	Super Skill (Door) 14	Battle The Power (Door) 24	Door Handle 34	Spiral Right Battle Power 44	Left Powerball 54	Middle Left 5 Million 64	Power Payoff 74	Piano Red 84
5 Red-Green J133-6 Q86	Fast Lock (Door) 15	The Spiral (Door) 25	Left Inlane 2 35	Spiral "10 Million" 45	The Camera 55	Upper Left 5 Million 65	Upper Right 5 Million 75	Slot Machine 85
6 Red-Blue J133-7 Q85	Lite Gumball (Door) 16	Clock Million (Door) 26	Door Panel "Gum" 36	Spiral "Extra Ball" 46	Right Ramp The Power 56	Right Special 66	Mini Playfield 500,000 76	Right Lane Gumball 86
7 Red-Violet J133-8 Q84	Town Square Madness (Door) 17	Super Slot (Door) 27	Lower Left 5 Million 37	Shoot Again 47	Lock Extra Ball 57	Right Powerball 67	Mini Playfield 1,000,000 77	Buy-In Button 87
8 Red-Gray J133-9 Q83	Lite Extra Ball (Door) 18	Door Panel "Ball" 28	Dead End 38	Right Inlane 48	Lock Arrow 58	Right Lane Spiral 68	Mini Playfield 750,000 78	Start Button 88

J1XX = Power Driver Board

SWITCHES

White Green

Dedicated Grounded Switches	Column \ Row	1 Green-Brown J206-1 U20-18	2 Green-Red J206-2 U20-17	3 Green-Orange J206-3 U20-16	4 Green-Yellow J206-4 U20-15	5 Green-Black J206-5 U20-14	6 Green-Blue J206-6 U20-13	7 Green-Violet J206-7 U20-12	8 Green-Gray J206-9 U20-11	9 Gray-White * J5-1	Flipper Grounded Switches
	Orange-Brown (1) J205-1 Left Coin Chute D1	1 White-Brown J208-1 U18-11	Right Inlane 11	Slam Tilt 21	Left Jet Bumper 31	Dead End 41	Gumball Popper Lane 51	Lower Skill 61	Not Used 71	Lower Right Magnet 81	
Orange-Red (2) J205-2 Center Coin Chute D2	2 White-Red J208-2 U18-9	Right Outlane 12	Coin Door Closed 22	Right Jet Bumper 32	The Camera 42	Hitch-Hiker 52	Center Skill 62	Auto-Fire Kicker 72	Not Used 82	Clock 0 Minutes 92	Blue-Violet J905-1 Right Flipper Opto F2
Orange-Black (3) J205-3 Right Coin Chute D3	3 White-Orange J208-3 U18-5	Start Button 13	Buy-In Button 23	Lower Jet Bumper 33	Player Piano 43	Left Ramp Enter 53	Upper Skill 63	Right Ramp 73	Left Magnet 83	Clock 45 Minutes 93	Black-Blue J906-3 Left Flipper End of Stroke F3
Orange-Yellow (4) J205-4 4th Coin Chute D4	4 White-Yellow J208-4 U18-7	Plumb Bob Tilt 14	Always Closed 24	Left Slingshot 34	Mini Playfield Enter 44	Left Ramp 54	Upper Right 5 Million 64	Gumball Popper 74	Center Lock 84	Clock 30 Minutes 94	Blue-Gray J905-2 Left Flipper Opto F4
Orange-Green (5) J205-6 Normal Function Test Function Service Credits Escape D5	5 White-Green J208-5 U19-11	Right Trough 15	Far Left Trough 25	Right Slingshot 35	Mini Playfield Left (2) 45	Gumball Geneva 55	Power Payoff (2) 65	Mini Playfield Top 75	Upper Lock 85	Clock Hour 1 95	Black-Violet J906-4 Upper Right Flipper End of Stroke F5
Orange-Blue (6) J205-7 Normal Function Test Function Volume Down Down D6	6 White-Blue J208-7 U19-9	Center Trough 16	Trough Proximity 26	Left Outlane 36	Mini Playfield Right (2) 46	Gumball Exit 56	Middle Right 5 Million 1 66	Mini Playfield Exit 76	Not Used 86	Clock Hour 2 96	Black-Yellow J905-3 Upper Right Flipper Opto F6
Orange-Violet (7) J205-8 Normal Function Test Function Volume Up Up D7	7 White-Violet J208-8 U19-5	Left Trough 17	Ball Shooter 27	Left Inlane 1 37	Clock Millions 47	Slot Proximity 57	Middle Right 5 Million 2 67	Middle Left 5 Million 77	Gumball Enter 87	Clock Hour 3 97	Black-Gray J906-5 Upper Left Flipper End of Stroke F7
Orange-Gray (8) J205-9 Normal Function Test Function Begin Test Enter D8	8 White-Gray J208-9 U19-7	Outhole 18	Rocket Kicker 28	Left Inlane 2 38	Lower Left 5 Million 48	Slot Kickout 58	Lower Right 5 Million 68	Upper Left 5 Million 78	Lock Lower 88	Clock Hour 4 98	Black-Blue J906-5 Upper Left Flipper Opto F8

J2XX = CPU Board, J9XX = Fliptronic II Board

* Located on 8 Driver P.C.B., A-16100, In backbox.

WARNINGS & NOTICES

WARNING

FOR SAFETY AND RELIABILITY, substitute parts and equipment modifications are not recommended. Use of Non-BALLY parts or modifications of game circuitry, may adversely affect game play, or may cause injuries.

SUBSTITUTE PART OR EQUIPMENT MODIFICATIONS may void FCC Type Acceptance.

BECAUSE THIS GAME IS PROTECTED by Federal copyright, trademark, and patent laws, unauthorized game conversions may be illegal under Federal law.

THIS 'CONVERSION' PRINCIPLE ALSO APPLIES to unauthorized facsimiles of BALLY equipment, logos, designs, publications, assemblies and games (or game feature not deemed to be public domain), whether manufactured with BALLY components or not.

Notice

MIDWAY® is a registered trademark of Midway Manufacturing Company. TWILIGHT ZONE™ and BALLY® are trademarks used by Midway with permission. WILLIAMS, Lane-change and Multi-ball are trademarks of WILLIAMS Electronics Games, Inc. Entire contents of this manual ©1993 MIDWAY MANUFACTURING COMPANY, manufacturers of BALLY Amusement Games. All rights reserved.

WARNING

NOTE: This equipment has been tested and found to comply with the limits for a Class A digital device, pursuant to Part 15 of the FCC Rules. These limits are designed to provide reasonable protection against harmful interference when the equipment is operated in a commercial environment. This equipment generated, uses, and can radiate radio frequency energy and if not installed and used in accordance with the instruction manual, may cause harmful interference to radio communications. Operation of this equipment in a residential area is likely to cause harmful interference in which case the user will be required to correct the interference at his own expense.

RF Interference Notice

CABLE HARNESS PLACEMENTS and ground strap routing on this game have been designed to keep RF radiation and conduction within levels accepted by the FCC Rules.

TO MAINTAIN THESE LEVELS, reposition harnesses and reconnect ground straps to their original placements, if they become disconnected during maintenance.

FCC STICKER. Check the back of your game to verify that an FCC-certification sticker was attached to your game at the factory. All Games that leave the BALLY plant have been tested and found to comply with FCC Rules. Because the sticker is proof of this fact, legal repercussions to the owner and distributor may result, if the sticker is missing. If you receive a game, manufactured after December 1982, that has no FCC sticker, call BALLY for advice or write us a note on your Game Registration Card. Be sure that the card bears your game's serial number.

FOR SERVICE...
CALL your authorized
BALLY Distributor

MIDWAY Manufacturing Company
3401 N. California
Chicago, IL 60618

"Twilight Zone™" Song
Written By George Kooymans
©1989

All Rights Administered by
SONY MUSIC Publishing
Nashville, TN 37202
All Rights Reserved
Used by Permission

Twilight Zone™ Television Series Theme Music
Written by Marius Constant
©1959 Renewed 1987 CBS Entertainment Inc.
All Rights Reserved
Used by Permission

**CAUTION: Transport this game ONLY
with hinged backbox DOWN!**